

### Features

- 3.3V version of PI49FCT805/806
- Extremely low output skew: 0.5ns
- Monitor output pin
- Clock busing with 3-state control
- TTL input and CMOS output compatible
- Industrial operation at  $-40^{\circ}\text{C}$  to  $85^{\circ}\text{C}$
- Extremely low static power (1mW, typ.)
- Hysteresis on all inputs
- Packaging (Pb-free & Green available):
  - 20-pin 300-mil wide SOIC (S)
  - 20-pin 150-mil wide QSOP (Q)
  - 20-pin 209-mil wide SSOP (H)

### Description

Pericom Semiconductor's PI49FCT3805 is a 3.3V non-inverting clock driver and the PI49FCT3806 is a 3.3V inverting clock driver designed with two independent groups of buffers. These buffers have 3-state Output Enable inputs (active LOW) with a 1-in, 5-out configuration per group. Each clock driver consists of two banks of drivers, driving five outputs each from a standard TTL compatible CMOS input.

### PI49FCT3805 Block Diagram

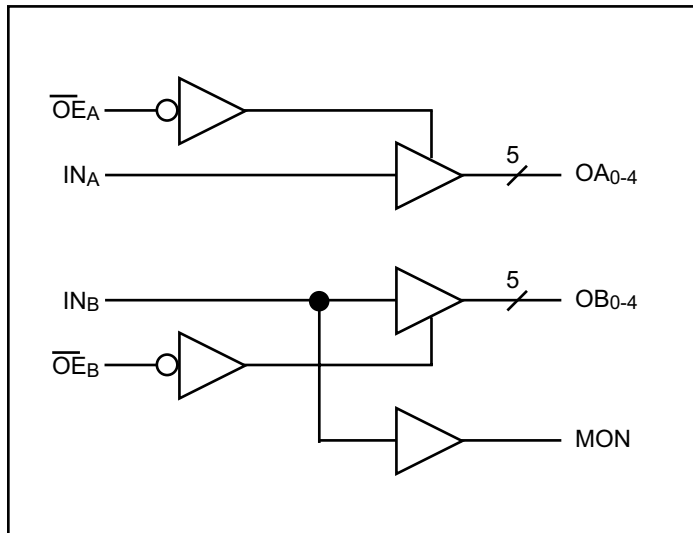

### PI49FCT3806 Block Diagram

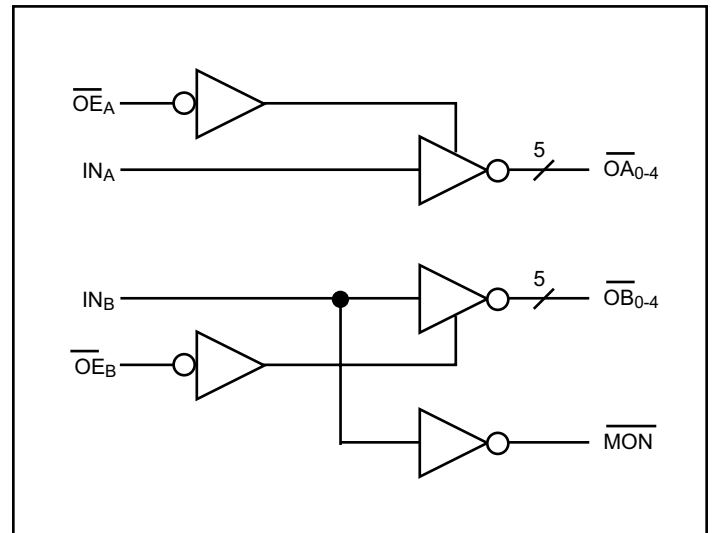

**Pin Description**

Pin Name	Description
$\overline{OE}_A, \overline{OE}_B$	3-State Output Enable Inputs (Active LOW)
$IN_A, IN_B$	Clock Inputs
$oA_N, oB_N$	Clock Outputs
MON	Monitor Output
GND	Ground
$V_{CC}$	Power

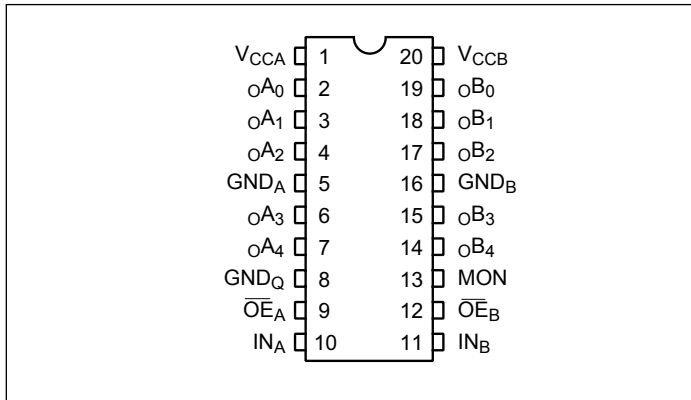
**PI49FCT3805 Pin Configuration**

**PI49FCT3805 Truth Table<sup>(1)</sup>**

Inputs		Outputs	
$\overline{OE}_A, \overline{OE}_B$	$IN_A, IN_B$	$oA_N, oB_N$	MON
L	L	L	L
L	H	H	H
H	L	Z	L
H	H	Z	H

**Note:**

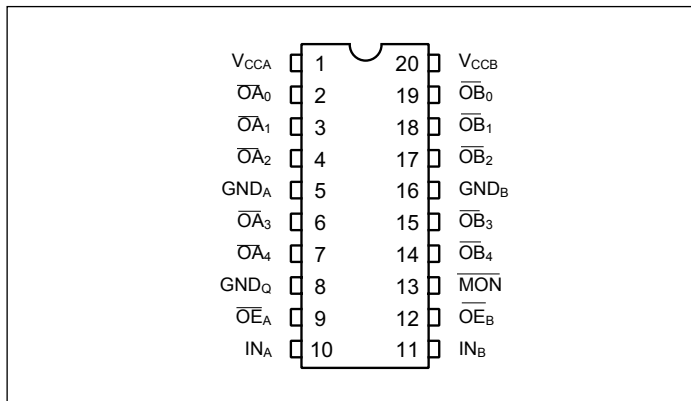
- H = High Voltage Level, L = Low Voltage Level  
Z = High Impedance

**PI49FCT3806 Pin Configuration**

**PI49FCT3806 Truth Table<sup>(1)</sup>**

Inputs		Outputs	
$\overline{OE}_A, \overline{OE}_B$	$IN_A, IN_B$	$oA_N, oB_N$	MON
L	L	H	H
L	H	L	L
H	L	Z	H
H	H	Z	L

- H = High Voltage Level, L = Low Voltage Level, Z = High Impedance

**Capacitance ( $T_A = 25^\circ\text{C}$ ,  $f = 1\text{ MHz}$ )**

Parameters <sup>(1)</sup>	Description	Test Conditions	Typ	Max.	Units
$C_{IN}$	Input Capacitance	$V_{IN} = 0V$	3.0	6.0	pF
$C_{OUT}$	Output Capacitance	$V_{OUT} = 0V$	6.0	8.0	

**Note:**

- This parameter is determined by device characterization but is not production tested.

## Electrical Specifications

**Maximum Ratings** (Above which the useful life may be impaired. For user guidelines, not tested.)

Storage Temperature.....	-65°C to +150°C
Ambient Temperature with Power Applied.....	-40°C to +85°C
Supply Voltage to Ground Potential (Inputs & V <sub>CC</sub> Only)....	-0.5V to +7.0V
Supply Voltage to Ground Potential (Outputs & I/O Only) .	-0.5V to +7.0V
DC Input Voltage .....	-0.5V to +7.0V
DC Output Current .....	120 mA
Power Dissipation .....	0.5W

**Note:**

Stresses greater than those listed under MAXIMUM RATINGS may cause permanent damage to the device. This is a stress rating only and functional operation of the device at these or any other conditions above those indicated in the operational sections of this specification is not implied. Exposure to absolute maximum rating conditions for extended periods may affect reliability.

**DC Electrical Characteristics** (T<sub>A</sub> = -40°C to +85°C, V<sub>CC</sub> = 3.3V ±0.3V)

Symbol	Parameter	Test Condition <sup>(1)</sup>		Min.	Typ.	Max.	Units
V <sub>OH</sub>	Output High Voltage V <sub>CC</sub> = 3.0V, V <sub>IN</sub> = V <sub>IL</sub> or V <sub>IH</sub>	V <sub>CC</sub> = Min., V <sub>IN</sub> = V <sub>IH</sub> or V <sub>IL</sub>	I <sub>OH</sub> = -0.1mA I <sub>OH</sub> = -8mA	V <sub>CC</sub> -0.2 2.4 (3)	- 3.0		V
V <sub>OL</sub>	Output Low Voltage V <sub>CC</sub> = 3.0V, V <sub>IN</sub> = V <sub>IL</sub> or V <sub>IH</sub>	V <sub>CC</sub> = Min., V <sub>IN</sub> = V <sub>IH</sub> or V <sub>IL</sub>	I <sub>OL</sub> = 0.1mA I <sub>OL</sub> = 16mA I <sub>OL</sub> = 24mA		- 0.2 0.3	0.2 0.4 0.5	
V <sub>IH</sub>	Input High Voltage	Guaranteed Logic HIGH level	Input Pins	2.0		5.5	
V <sub>IL</sub>	Input Low Voltage	Guaranteed Logic LOW level	Input Pins	-0.5		0.8	
I <sub>IH</sub>	Input High Current	V <sub>CC</sub> = Max	V <sub>IN</sub> = V <sub>CC</sub> (Input Pins)	-1		1	μA
I <sub>IL</sub>	Input Low Current	V <sub>CC</sub> = Max	V <sub>IN</sub> = GND (Input & I/O Pins)	-1		1	
I <sub>OZH</sub>	High Impedance Output Current	V <sub>CC</sub> = Max., All outputs Disabled	V <sub>OUT</sub> = V <sub>CC</sub> V <sub>OUT</sub> = GND	-1		1	
I <sub>OZL</sub>	High Impedance Output Current	V <sub>CC</sub> = Max., All outputs Disabled	V <sub>OUT</sub> = V <sub>CC</sub> V <sub>OUT</sub> = GND	-1		1	
V <sub>IK</sub>	Clamp Diode Voltage	V <sub>CC</sub> = Min., I <sub>IN</sub> = -18mA			-0.7	-1.2	V
I <sub>ODH</sub>	Output HIGH Current	V <sub>OUT</sub> = 3.3V, V <sub>IN</sub> = V <sub>IL</sub> or V <sub>IH</sub> , V <sub>OUT</sub> = 1.5V <sup>(4)</sup>		-35	-86	-110	mA
I <sub>ODL</sub>	Output LOW Current	V <sub>OUT</sub> = 3.3V, V <sub>IN</sub> = V <sub>IL</sub> or V <sub>IH</sub> , V <sub>OUT</sub> = 1.5V <sup>(4)</sup>		50	168	200	
I <sub>OS</sub>	Short Circuit <sup>(5)</sup> Current	V <sub>CC</sub> = Max., V <sub>OUT</sub> = GND <sup>(5)</sup>		-60	-135	-240	
V <sub>H</sub>	Input Hysteresis				150		mV

1. For Max. or Min. conditions, use appropriate value specified under Electrical Characteristics for the applicable device type.

2. Typical values are at V<sub>CC</sub> = 3.3V, +25°C ambient and maximum loading.

3. V<sub>OH</sub> = V<sub>CC</sub> - 0.6V at rated current.

4. This parameter is determined by device characterization but is not production tested.

5. Not more than one output should be shorted at one time. Duration of the test should not exceed one second.

**Power Supply Characteristics** ( $T_A = -40^\circ\text{C}$  to  $+85^\circ\text{C}$ ,  $V_{CC} = 3.3\text{V} \pm 0.3\text{V}$ )

Parameters	Description	Test Conditions <sup>(1)</sup>		Min.	Typ <sup>(2)</sup>	Max.	Units
$I_{CC}$	Quiescent Power Supply Current	$V_{CC} = \text{Max.}$	$V_{IN} = \text{GND}$ or $V_{CC}$	—		30	$\mu\text{A}$
$\Delta I_{CC}$	Supply Current per Inputs @ TTL HIGH	$V_{CC} = \text{Max.}$	$V_{IN} = V_{CC} - 0.6\text{V}^{(3)}$	—	11	300	
$I_{CCD}$	Supply Current per Input per MHz <sup>(4)</sup>	$V_{CC} = \text{Max.}$ , $\overline{\text{Outputs}} \text{ Open}$ $\text{OEA or OEB} = \text{GND}$ Per Output Toggling 50% Duty Cycle	$V_{IN} = V_{CC}$ $V_{IN} = \text{GND}$	—	0.1	0.16	mA/ MHz
$I_C$	Total Power Supply Current <sup>(6)</sup>	$V_{CC} = \text{Max.}$ , Outputs Open $f_O = 10 \text{ MHz}$ 50% Duty Cycle $\overline{\text{OEA}} \text{ or } \overline{\text{OEB}} = \text{GND}$ Mon. Outputs Toggling	$V_{IN} = V_{CC}$ $V_{IN} = \text{GND}$	—	3.3	9.0 <sup>(5)</sup>	mA
			$V_{IN} = V_{CC} - 0.6\text{V}$ $V_{IN} = \text{GND}$	—	3.3	10.0 <sup>(5)</sup>	
		$V_{CC} = \text{Max.}$ , Outputs Open $f_O = 2.5 \text{ MHz}$ 50% Duty Cycle $\overline{\text{OEA}} \text{ or } \overline{\text{OEB}} = \text{GND}$ Eleven Outputs Toggling	$V_{IN} = V_{CC}$ $V_{IN} = \text{GND}$	—	1.8	6.0 <sup>(5)</sup>	
			$V_{IN} = V_{CC} - 0.6\text{V}$ $V_{IN} = \text{GND}$	—	1.8	7.0 <sup>(5)</sup>	

1. For Max. or Min. conditions, use appropriate value specified under Electrical Characteristics for the applicable device.

2. Typical values are at  $V_{CC} = 3.3\text{V}$ ,  $+25^\circ\text{C}$  ambient.

3. Per TTL driven input ( $V_{IN} = V_{CC} - 0.6\text{V}$ ); all other inputs at  $V_{CC}$  or GND.

4. This parameter is not directly testable, but is derived for use in Total Power Supply Calculations.

5. Values for these conditions are examples of the  $I_C$  formula. These limits are guaranteed but not tested.

6.  $I_C = I_{\text{QUIESCENT}} + I_{\text{INPUTS}} + I_{\text{DYNAMIC}}$

$$I_C = I_{CC} + \Delta I_{CC} D_H N_T + I_{CCD} (f_O N_O)$$

$I_{CC}$  = Quiescent Current

$\Delta I_{CC}$  = Power Supply Current for a TTL High Input ( $V_{IN} = V_{CC} - 0.6\text{V}$ )

$D_H$  = Duty Cycle for TTL Inputs High

$N_T$  = Number of TTL Inputs at  $D_H$

$I_{CCD}$  = Dynamic Current Caused by an Input Transition Pair (HLH or LHL)

$f_O$  = Output Frequency

$N_O$  = Number of Outputs at  $f_O$

**All currents are in milliamps and all frequencies are in megahertz.**

**Switching Characteristics** ( $T_A = -40^\circ\text{C}$  to  $+85^\circ\text{C}$ ,  $V_{CC} = 3.3\text{V} \pm 0.3\text{V}$ )

Parameter	Description	Test Conditions <sup>(1)</sup>	3805 3806		3805A 3806A		3805B 3806B		3805C 3806C		Units
			Com.		Com.		Com.		Com.		
			Min.	Max.	Min.	Max.	Min.	Max.	Min.	Max.	
$t_{PLH}$ $t_{PLH}$	Propagation Delay $IN_A$ to $OA_N$ , $IN_B$ to $OB_N$	$C_L = 50\text{pF}$ $R_L = 500\Omega$	1.5	6.5	1.5	5.8	1.5	5.0	1.5	4.5	ns
$t_{PZH}$ $t_{PZL}$	Output Enable Time $\overline{OE}_A$ to $OA_N$ , $\overline{OE}_B$ to $OB_N$		1.5	8.0	1.5	8.0	1.5	6.5	1.5	6.2	
$t_{PHL}$ $t_{PLZ}$	Output Disable Time $\overline{OE}_A$ to $OA_N$ , $\overline{OE}_B$ to $OB_N$		1.5	7.0	1.5	7.0	1.5	6.0	1.5	5.0	
$t_{SK(o)}$ <sup>(3)</sup>	Skew between two outputs of same package (same transition)			0.7		0.7		0.5		0.5	
$t_{SK(p)}$ <sup>(3)</sup>	Skew between opposite transitions ( $t_{PHL} - t_{PLH}$ ) of the same output			1.0		0.7		0.5		0.5	
$t_{SK(t)}$ <sup>(3)</sup>	Skew between two outputs of different package at same temperature (Same transition)			1.5		1.2		1.0		0.8	

**Note:**

1. See test circuit and waveforms
2. Minimum limits are guaranteed but not tested on Propagation Delays.
3. Skew measured at worst cast temperature (max. temp).

**Tests Circuits for All Outputs<sup>(1)</sup>**

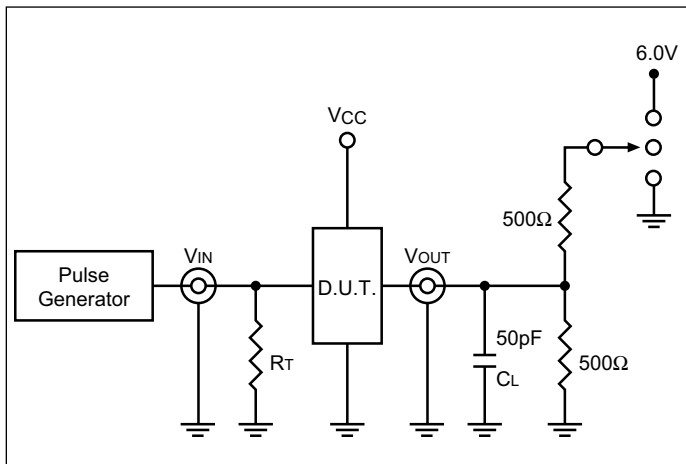
 except for  $F_{IN} > 100\text{ MHz}$ 

**Switch Position**

Test	Switch
Disable LOW	6V
Enable LOW	
Disable HIGH	GND
Enable HIGH	
All Other Inputs	Open

**Definitions:**

$C_L$  = Load capacitance: includes jig and probe capacitance.  
 $R_T$  = Termination resistance: should be equal to  $Z_{OUT}$  of the Pulse Generator.

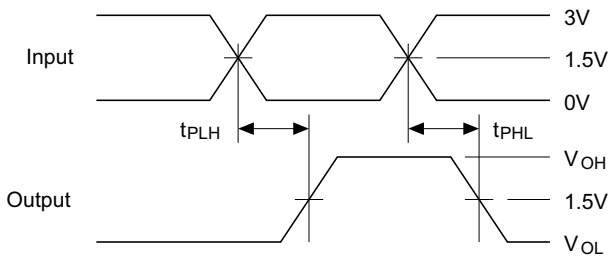
**Switching Waveforms**



Propagation Delay

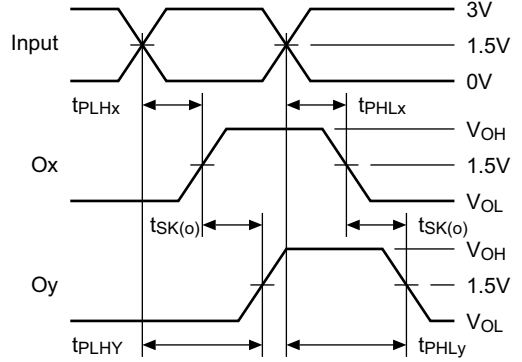

$$t_{SK(O)} = |t_{PLH_V} - t_{PLH_X}| \text{ or } |t_{PHL_V} - t_{PHL_X}|$$

Output Skew -  $t_{SK(O)}$

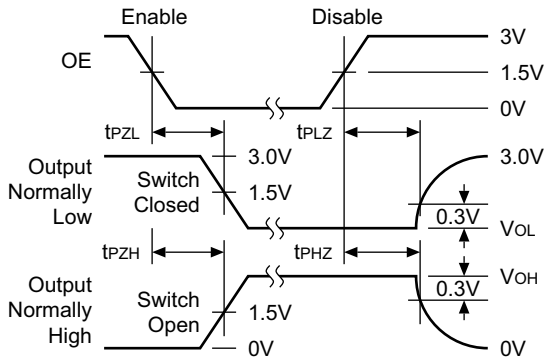

Enable and Disable Times

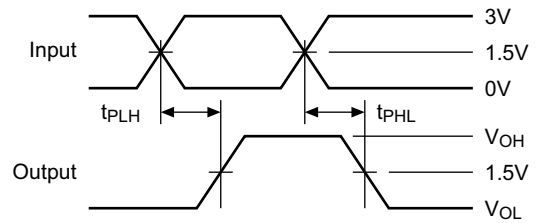

$$t_{SK(P)} = |t_{PHL} - t_{PLH}|$$

Pulse Skew -  $t_{SK(P)}$

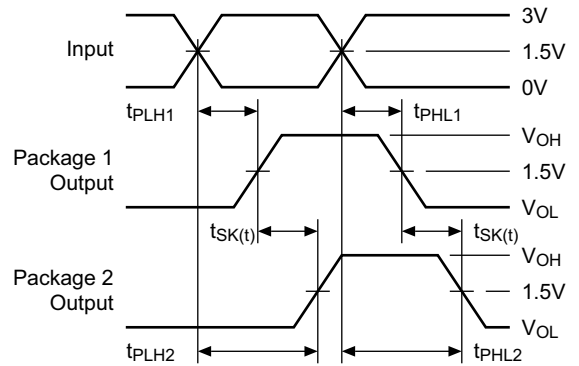

$$t_{SK(t)} = |t_{PLH2} - t_{PLH1}| \text{ or } |t_{PHL2} - t_{PHL1}|$$

Package Skew -  $t_{SK(t)}$

**Packaging Mechanical: 20-pin SSOP (H20)**

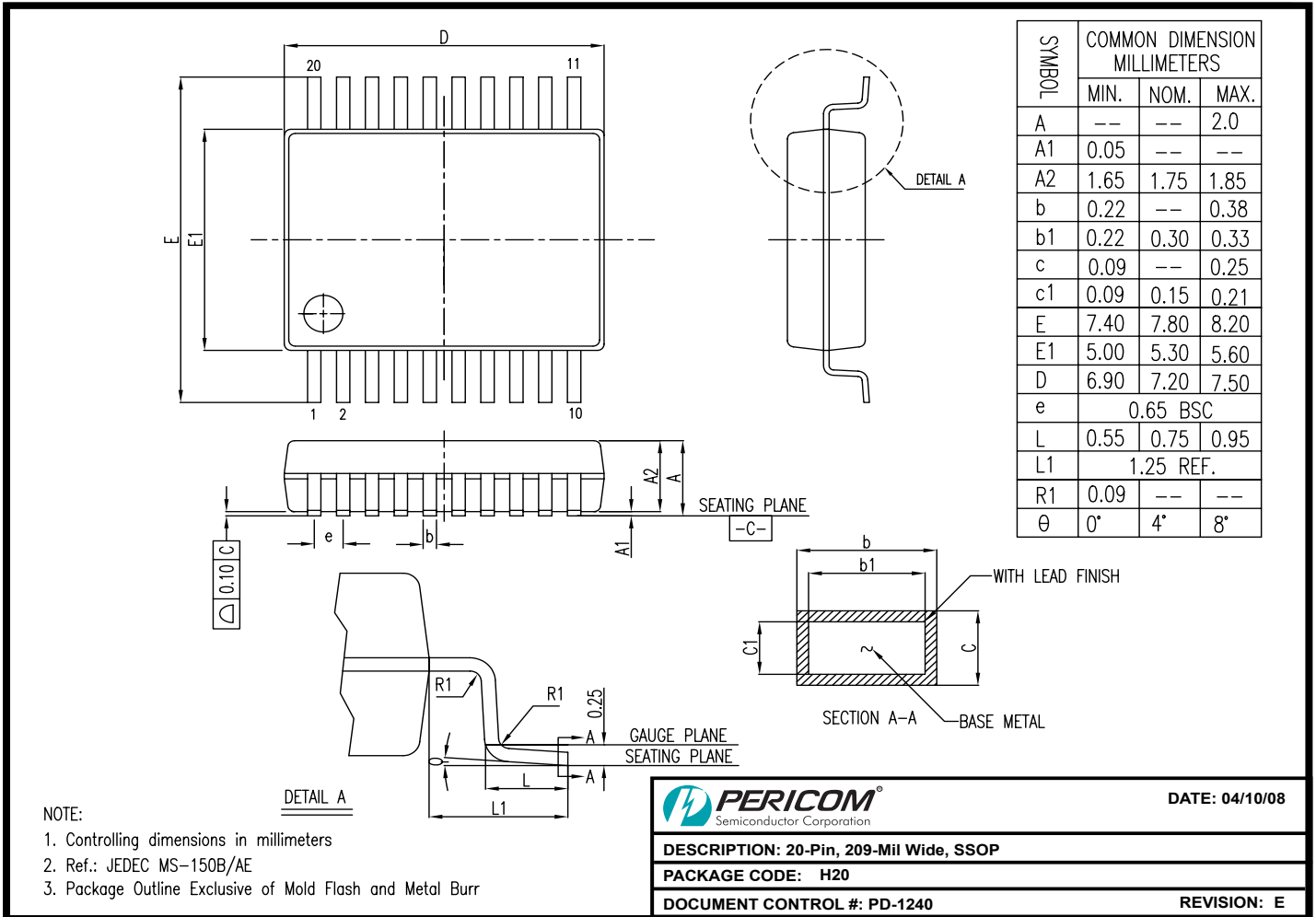

08-0140

**Note:**

- For latest package info, please check: <http://www.pericom.com/products/packaging/mechanicals.php>

**Packaging Mechanical: 20-pin SOIC (S)**

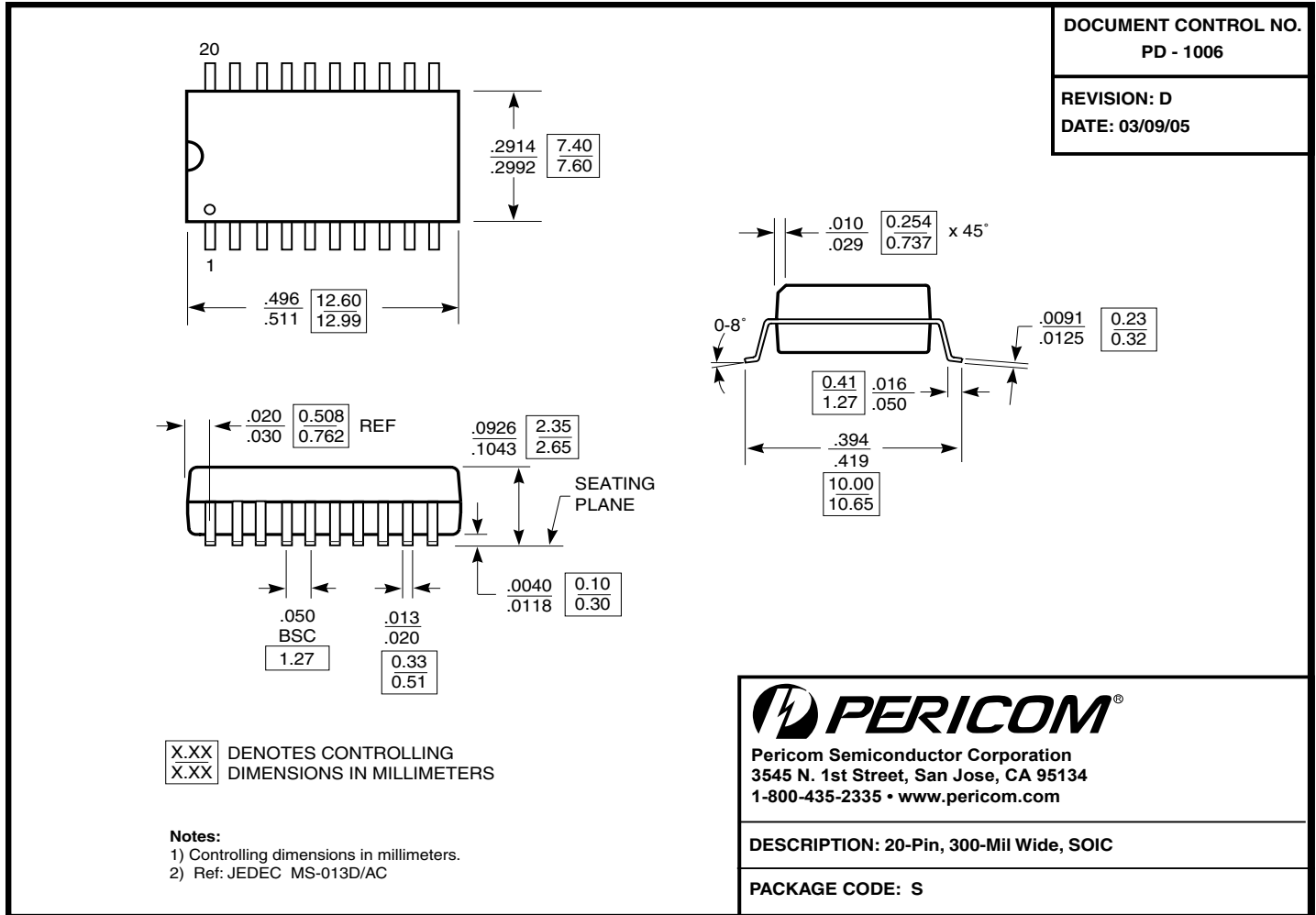

Note:

- For latest package info, please check: <http://www.pericom.com/products/packaging/mechanicals.php>



**Packaging Mechanical: 20-contact SSOP (H20)**

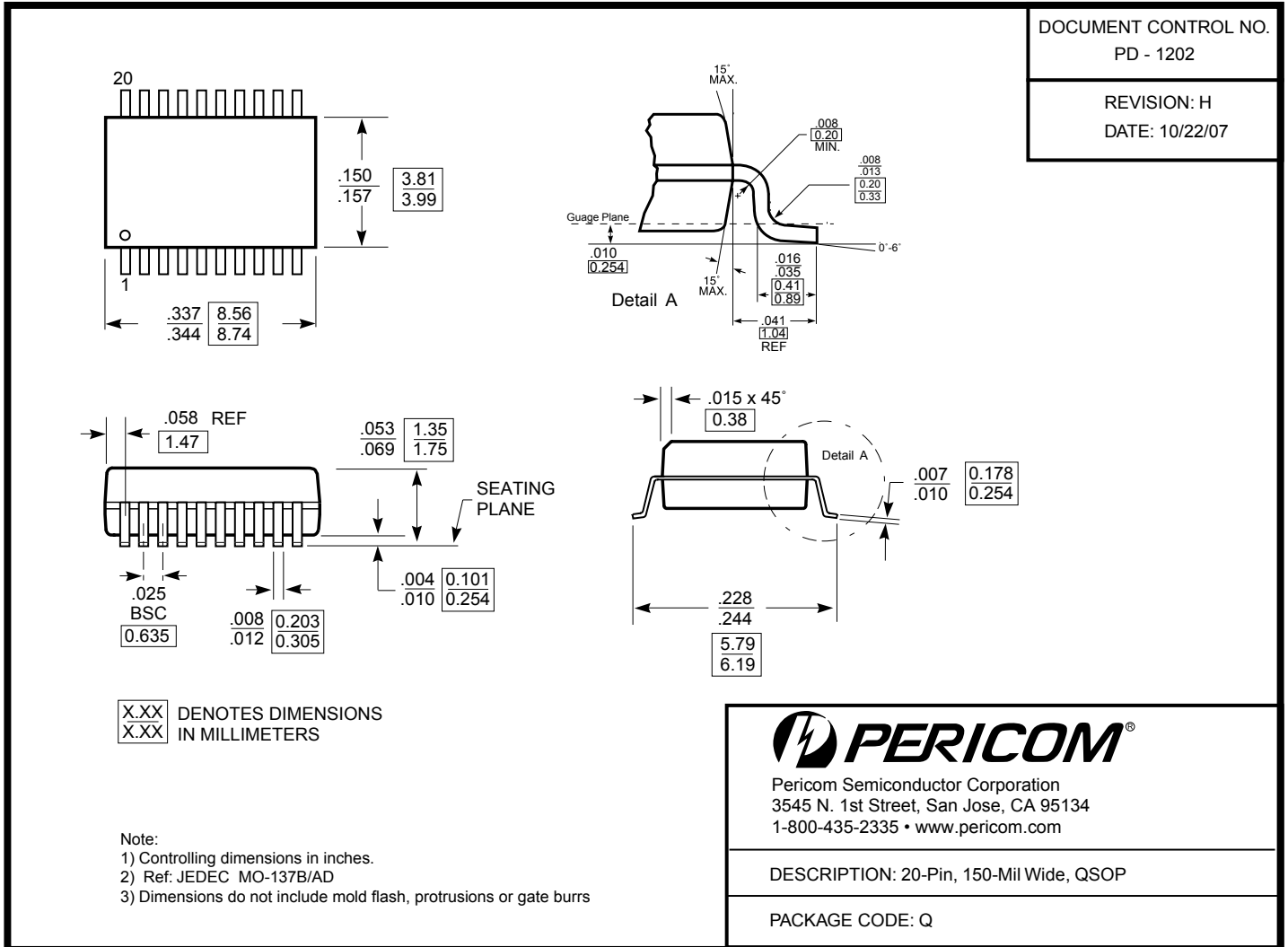

Note:

- For latest package info, please check: <http://www.pericom.com/products/packaging/mechanicals.php>

**PI49FCT3805 Ordering Information**

Ordering Code	Package Code	Speed Grade	Package Description
PI49FCT3805AHEX	H	A	Pb-free & Green, 20-pin 209-mil SSOP
PI49FCT3805AQEX	Q	A	Pb-free & Green, 20-pin 150-mil QSOP
PI49FCT3805ASEX	S	A	Pb-free & Green, 20-pin 300-mil SOIC
PI49FCT3805BHEX	H	B	Pb-free & Green, 20-pin 209-mil SSOP
PI49FCT3805BQEX	Q	B	Pb-free & Green, 20-pin 150-mil QSOP
PI49FCT3805CHEX	H	C	Pb-free & Green, 20-pin 209-mil SSOP
PI49FCT3805CQEX	Q	C	Pb-free & Green, 20-pin 150-mil QSOP
PI49FCT3805CSEX	S	C	Pb-free & Green, 20-pin 300-mil SOIC
PI49FCT3805HEX	H	Blank	Pb-free & Green, 20-pin 209-mil SSOP
PI49FCT3805QEX	Q	Blank	Pb-free & Green, 20-pin 150-mil QSOP
PI49FCT3805SEX	S	Blank	Pb-free & Green, 20-pin 300-mil SOIC

**Notes:**

- Thermal characteristics can be found on the company web site at [www.pericom.com/packaging/](http://www.pericom.com/packaging/)
- E = Pb-free and Green
- Adding an X suffix = Tape/Reel

**PI49FCT3806 Ordering Information**

Ordering Code	Package Code	Speed Grade	Package Description
PI49FCT3806H	H	Blank	20-pin 209-mil SSOP
PI49FCT3806QE	Q	Blank	Pb-free & Green, 20-pin 150-mil QSOP
PI49FCT3806S	S	Blank	20-pin 300-mil SOIC
PI49FCT3806SE	S	Blank	Pb-free & Green, 20-pin 300-mil SOIC
PI49FCT3806AHE	H	A	Pb-free & Green, 20-pin 209-mil SSOP
PI49FCT3806BQE	Q	B	Pb-free & Green, 20-pin 150-mil QSOP
PI49FCT3806CHE	H	C	Pb-free & Green, 20-pin 209-mil SSOP
PI49FCT3806CQE	Q	C	Pb-free & Green, 20-pin 150-mil QSOP

**Notes:**

- Thermal characteristics can be found on the company web site at [www.pericom.com/packaging/](http://www.pericom.com/packaging/)
- E = Pb-free and Green
- Adding an X suffix = Tape/Reel