

Features

- 140MHz operation (PI6CV2304)
- 160 MHz operation (PI6CV304)
- Low noise, low skew: 150ps max
- Fast rise/fall time: 1.0ns typ.
- Fast propagation delay: 2.0ns typ.
- 5V I/O tolerant input
- Industrial temperature (−40°C to 85°C)
- 3.3V power supply
- Packaging (Pb-free & Green available)
 - 8-pin TSSOP (L)
 - 8-pin SOIC (W)

Applications

- 33 MHz PCI-to-133 MHz PCIX controllers
- 80 MHz for 10/100 Mbps Ethernet
- 125 MHz for Gigabit networking
- 155 MHz for Optical OC3/SDH/SONET

Description

Pericom’s PI6CV304 and PI6CV2304 are low-skew, low-noise, high-speed clock buffers and are ideal for computing, networking, and communication applications. Application examples include PCI(X) clock buffers in servers and workstations, PCI(X) Storage Area Network (SAN), and RAID controllers. They are used for networking and communications applications requiring 80 MHz for 10/100 Mbps Ethernet and 125 MHz for Gigabit networking clocks.

To reduce EMI emission and power consumption, all outputs can be disabled to 3-state by asserting a low signal to the OE (Output Enable) pin.

PI6CV2304 output impedance is 30-ohms. PI6CV304 output impedance is 20-ohms.

Function Table

Inputs		Output
CLK_IN	OE	Y[0:3]
X	L	Z
L	H	L
H	H	H

Block Diagram

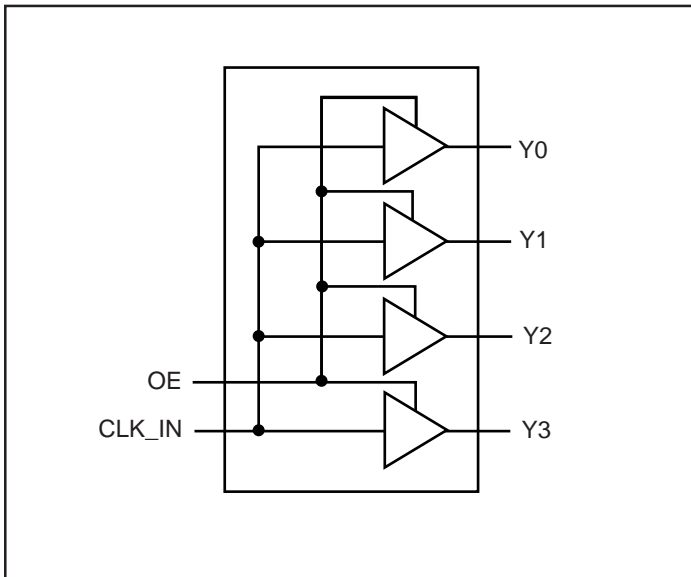

Pin Configuration

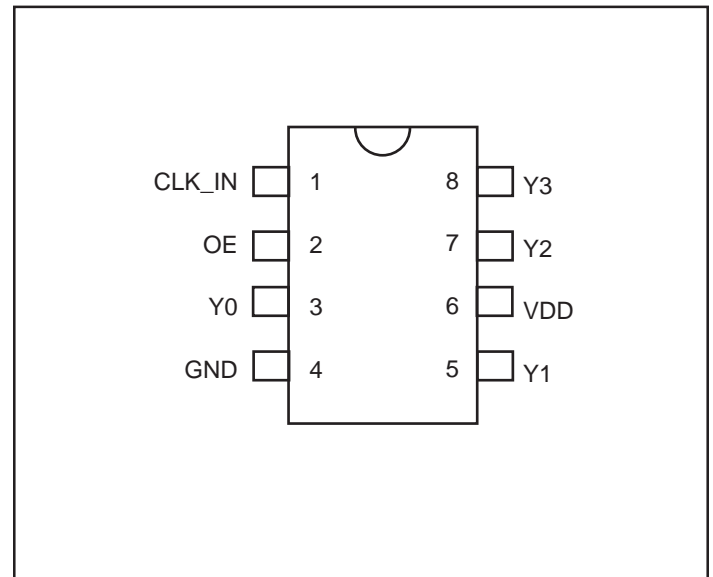

Pin Description

Pin #	Symbol	Type	Qty	Description
1	CLK_IN	Input	1	5V Tolerant clock input
2	OE	Input	1	Active High Output Enable. Y[0-3] outputs will be 3-stated when OE is low
3,5,7,8	Y[0-3]	Output	4	LVC MOS level outputs
4	GND	Ground	1	Ground
6	V _{DD}	Power	1	3.3V power

Absolute Maximum Ratings (Above which the useful life may be impaired. For user guidelines, not tested)

Supply Voltage (V _{DD})	-0.0V to +5.0V
Input Voltage	-0.5V to V _{DD} +0.5V
Industrial Operating Temperature	-40°C to +85°C
Storage Temperature	-65°C to +150°C
Junction Temperature	150°C
Input ESD MIL-883, method 3015, human body model	2KV

Operating Conditions

Symbol	Description	Min	Max	Unit
V _{DD}	I/O Supply, Analog Core Supply	3.0	3.6	V
T _A	Industrial Ambient Temperature	-40	+85	°C

PI6CV304 DC Characteristics Over Operating Conditions

Symbol	Parameter	Conditions	Min	Typ.	Max	Units
V_{IL}	Low Input Voltage				0.8	V
V_{IH}	High Input Voltage		2.0			
I_{IL}	Low Input Current	$V_{IN} = 0V$			-5	μA
I_{IH}	High Input Current	$V_{IN} = V_{DD}$			5	
V_{OL}	Low Output Voltage	$V_{DD} = 3.0V, I_{OL} = 12mA$			0.4	V
V_{OH}	High Output Voltage	$V_{DD} = 3.0V, I_{OH} = -12mA$	2.4			
C_O	Output Capacitance				7	pF
C_I	Input Capacitance				5	
I_{DD}	Supply Current	$C_L = 33pF/33MHz$		20		mA
		$C_L = 33pF/66MHz$		40		
		$C_L = 22pF/80MHz$		35		
		$C_L = 15pF/100MHz$		32		
		$C_L = 10pF/125MHz$		28		
		$C_L = 10pF/155MHz$		41		
Z_O	Output Impedance			20		Ω
L	Pin Inductance				7	nH

PI6CV304 AC Characteristics ($T_A = -40 \sim 85^\circ C, V_{DD} = 3.3V \pm 0.3V, 33pF/66MHz$ and $10pF/160MHz$)

Symbol	Parameter	Conditions	Min.	Typ.	Max.	Units
f_{IN}	Input frequency		0		160	MHz
t_{PLH}	Low-to-high propagation delay	CLK_IN to Y[0-3] rising edges @ 1.5V	1.0		3.0	ns
t_{PHL}	High-to-low propagation delay	CLK_IN to Y[0-3] falling edges @ 1.5V	1.0		3.0	
$t_{SK(O)}$	Output skew ⁽²⁾	@ 1.5V			100	ps
$t_{SK(P)}$	Pulse skew	@ 1.5V			300	
$t_{SK(T)}$	Package skew ⁽¹⁾	@ 1.5V			500	
t_R, t_F	Rise, Fall time	0.8V~2.0V			1.2	ns
t_{PZL}, t_{PZH}	Output enable time				5	
t_{PLZ}, t_{PHZ}	Output disable time				10	
t_{DC}	Output Duty Cycle	$t_{DC} = t_H/t_{CY}$, t_H = High Pulse Width, t_{CY} = Output Cycle Time, @ 1.5V	45		55	%

Note:

- Identical traces, loads, power supply.
- Maximum Output Skew is 100ps when frequency is below 125MHz with 10pF loading.

PI6CV2304 DC Characteristics Over Operating Conditions

Symbol	Parameter	Conditions	Min.	Typ.	Max.	Units
V _{IL}	Low Input Voltage				0.8	V
V _{IH}	High Input Voltage		2.0			
I _{IL}	Low Input Current	V _{IN} = 0V			-50	μA
I _{IH}	High Input Current	V _{IN} = V _{DD}			200	
V _{OL}	Low Output Voltage	V _{DD} = 3.0V, I _{OL} = 8 mA			0.4	V
V _{OH}	High Output Voltage	V _{DD} = 3.0V, I _{OH} = -8mA	2.4			
I _{DD}	Supply Current	C _L = 33pF/33MHz		20		mA
		C _L = 33pF/66MHz		41		
		C _L = 22pF/80MHz		35		
		C _L = 15pF/100MHz		34		
		C _L = 10pF/125MHz		31		
C _O	Output Capacitance				7	pF
C _I	Input Capacitance				5	
Z _O	Output Impedance			30		Ω
L	Pin Inductance				7	nH

PI6CV2304 AC Characteristics (T_A = -40~85°C, V_{DD} = 3.3V ±0.3V, 33pF/66MHz and 10pF/133MHz)

Symbol	Parameter	Conditions	Min.	Typ.	Max.	Units
f _{IN}	Input frequency		0		140	MHz
t _{PLH}	Low-to-high propagation delay	CLK_IN to Y[0-3] rising edges @ 1.5V	1.0		3.0	ns
t _{PHL}	High-to-low propagation delay	CLK_IN to Y[0-3] falling edges @ 1.5V	1.0		3.0	
t _{SK(O)}	Output skew	@ 1.5V			150	ps
t _{SK(P)}	Pulse skew	@ 1.5V			300	
t _{SK(T)}	Package skew ⁽¹⁾	@ 1.5V			500	
t _R , t _F	Rise, Fall time	0.8V~2.0V			1.35	ns
t _{PZL} , t _{PZH}	Output enable time				5	
t _{PLZ} , t _{PHZ}	Output disable time				10	
t _{DC}	Output duty cycle	t _{DC} = t _H /t _{CY} , t _H = High Pulse Width, t _{CY} = Output Cycle Time, @ 1.5V	45		55	%

Note: 1. Identical traces, loads, power supply.

Rise/Fall Time

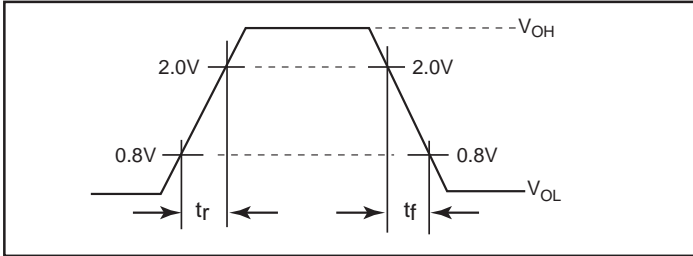

Note:

For test circuit: $R_S = 0$ for PI6CV2304, $R_S = 15$ ohms for PI6CV304
 $C_L = 10, 15, 22,$ or 33 pF, depending on frequency.

High-Level Output Voltage vs. High-Level Output Current

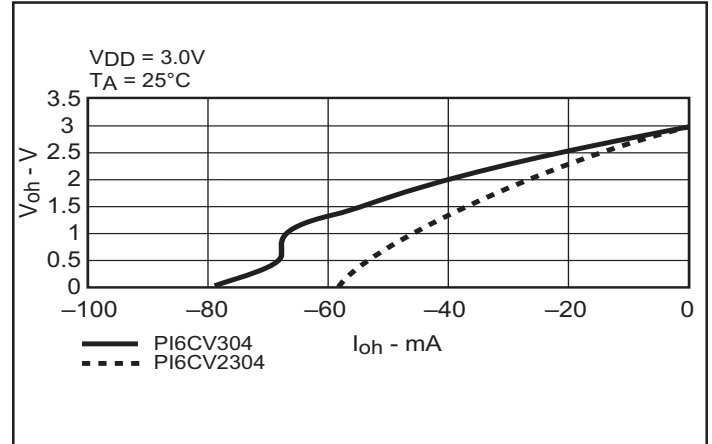

Low-Level Output Voltage vs. Low-Level Output Current

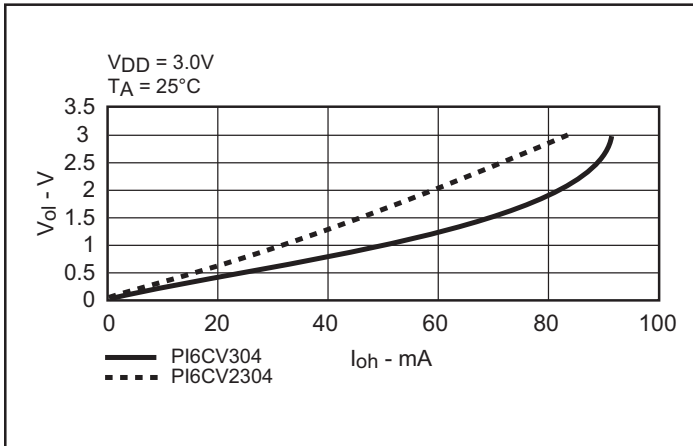

Switching Waveforms

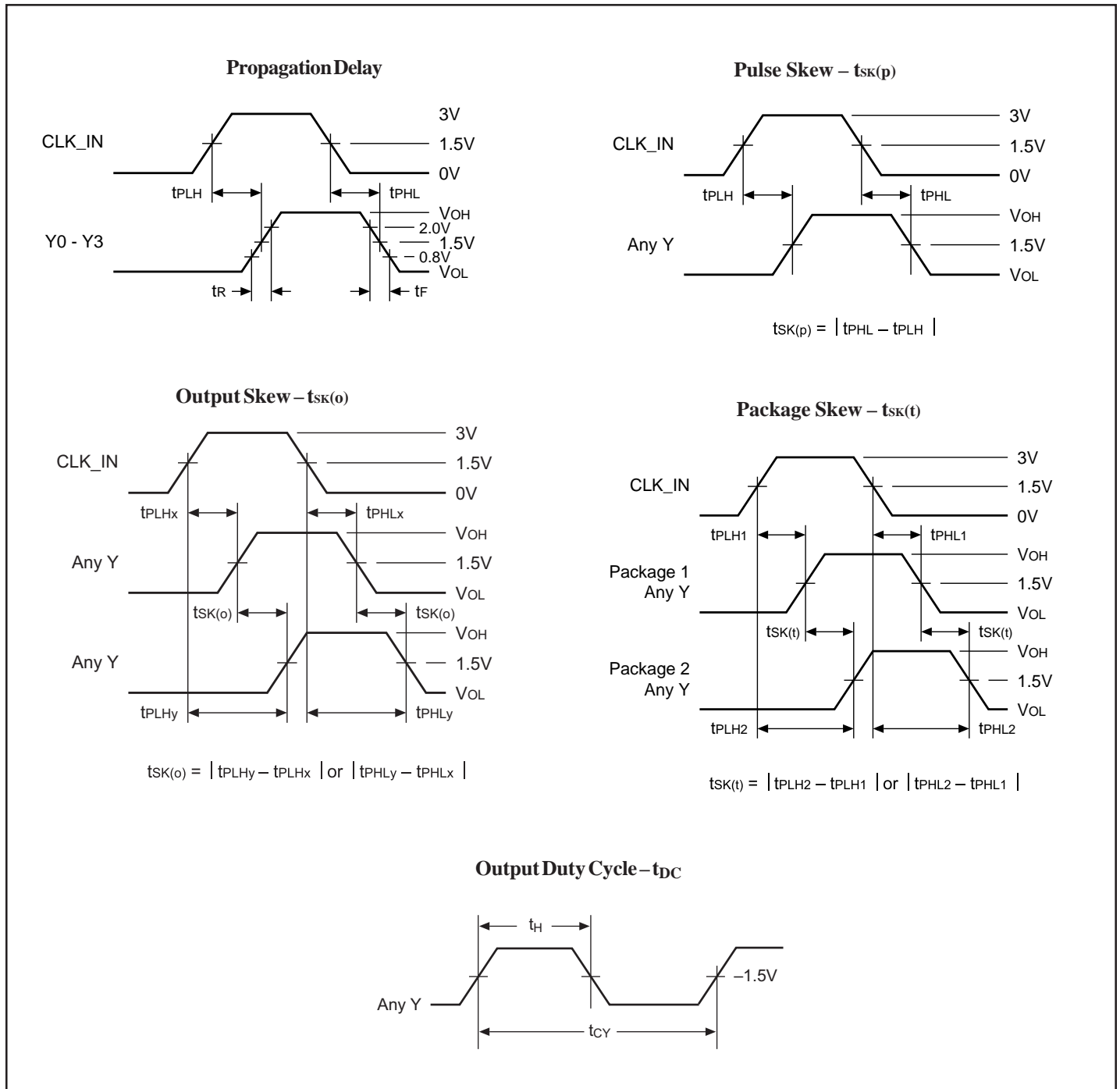

Packaging Mechanical: 8-Pin TSSOP (L)

DOCUMENT CONTROL NO.
PD - 1308

REVISION: E
DATE: 11/15/05

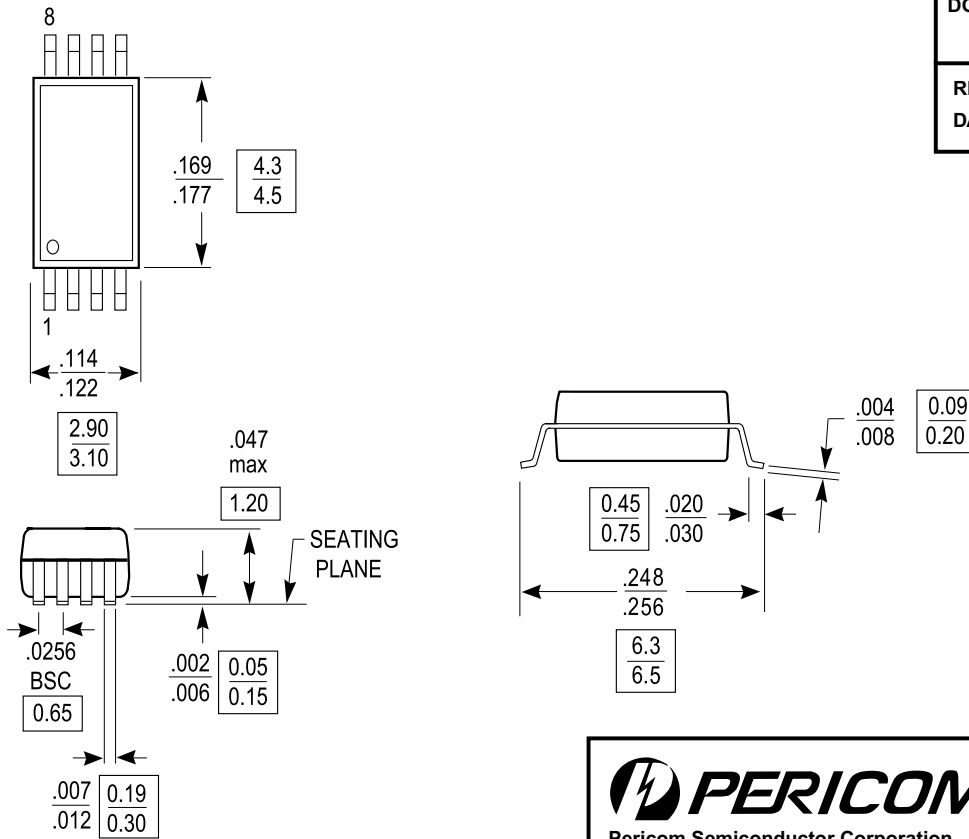

- Note:**
1. Package Outline Exclusive of Mold Flash and Metal Burr
 2. Controlling dimensions in millimeters
 3. Ref: JEDEC MO-153F/AA



Pericom Semiconductor Corporation
3545 N. 1st Street, San Jose, CA 95134
1-800-435-2335 • www.pericom.com

DESCRIPTION: 8-Pin, 173-Mil Wide, TSSOP

PACKAGE CODE: L

Note:

For latest package info, please check: <http://www.pericom.com/products/packaging/mechanicals.php>

Packaging Mechanical: 8-Pin SOIC (W)

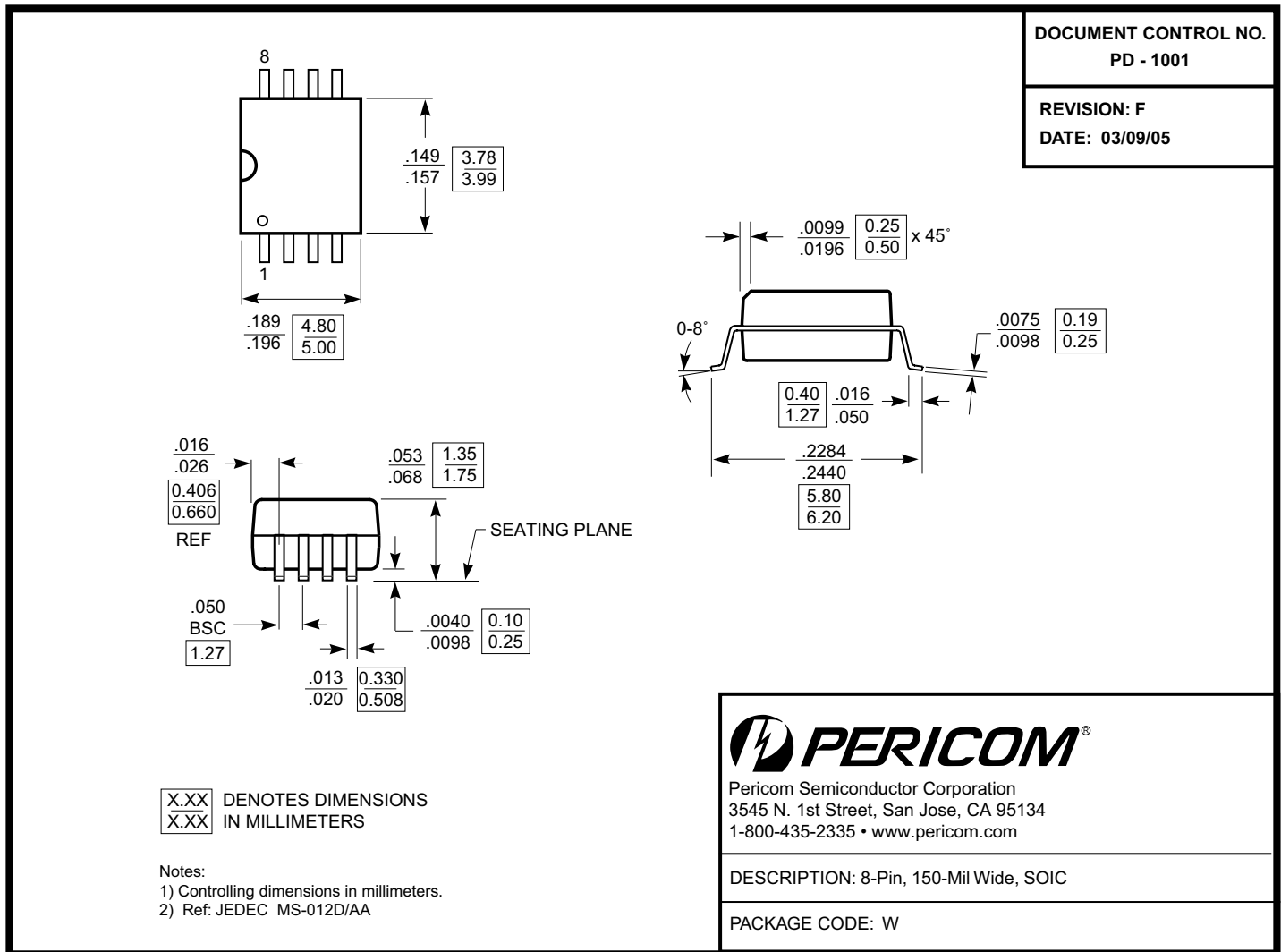

Note:

For latest package info, please check: <http://www.pericom.com/products/packaging/mechanicals.php>

Ordering Information

Ordering Code	Package Code	Package Type
PI6CV304L	L	8-pin 173-mil wide TSSOP
PI6CV304LE	L	Pb-free & Green, 8-pin 173-mil wide TSSOP
PI6CV304W	W	8-pin 150-mil wide SOIC
PI6CV304WE	W	Pb-free & Green, 8-pin 150-mil wide SOIC
PI6CV2304L	L	8-pin 173-mil wide TSSOP
PI6CV2304LE	L	Pb-free & Green, 8-pin 173-mil wide TSSOP
PI6CV2304WE	W	Pb-free & Green, 8-pin 150-mil wide SOIC

Notes:

- Thermal characteristics can be found on the company web site at www.pericom.com/packaging/