

Features

- Meets or Exceeds ANSI TIA/EIA-644-1955 Standard
- Signaling rates up to 660 Mbps
- Bus-Terminal ESD exceeds 2kV
- Low-Voltage Differential Signaling with typical Output Voltages of 350mV:
 - 100-ohm load (PI90LV01)
 - 50-ohm load (PI90LVB01)
- Typical Propagation Delay Times of 1.5ns
- Typical Power Dissipation of 20mW @200 MHz
- Low-Voltage TTL (LVTTTL) Level is 5V Tolerant
- Operates from a 3.3V supply
- Extended Industrial Temperature Operating Range: -40°C to 105°C
- Packaging (Pb-free & Green available):
 - 5-pin space-saving SOT23 (T)

Description

The PI90LV01 and PI90LVB01 are differential line drivers that use low-voltage differential signaling (LVDS) to support data rates up to 660 Mbps. These products are designed for applications requiring high-speed, low-power consumption, low-noise generation, and a small package.

The TIA/EIA-644 standard compliant electrical interface provides a minimum differential output voltage magnitude of 247mV into a 100-ohm load and receipt of 100mV signals with up to 1V of ground potential difference between a transmitter and receiver. The PI90LVB01 doubles the output drive current to achieve LVDS levels with a 50-ohm load.

A low-voltage TTL/CMOS input level is translated by the device into a low-voltage (350mV) differential output signal.

Applications

Applications include point-to-point (single termination) and multi-point (double termination) baseband data transmissions over controlled impedance media. The transmission media can be printed circuit board traces, backplanes, or cables.

The PI90LV01 and companion line receivers (PI90LV02 and PI90LVT02) provide new alternatives to RS-232, PECL and ECL devices for high-speed, point-to-point interface applications.

Function Table

Inputs	Outputs	
D _{IN}	Y	Z
H	H	L
L	L	H
Open	L	H

Notes:

- H = High
- L = Low
- X = High or Low
- High Z = High Impedance

Logic Diagram

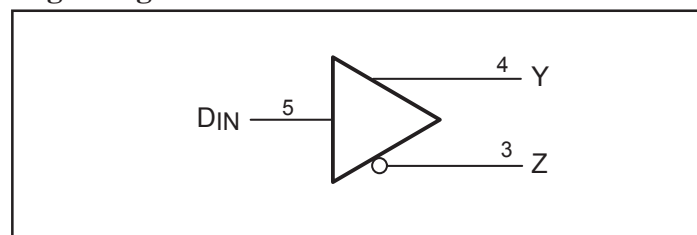

Pinout

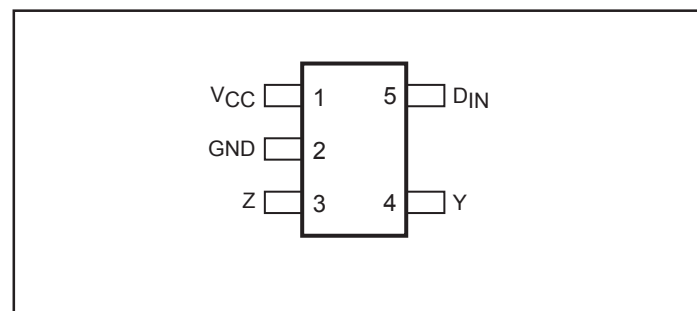

Absolute Maximum Ratings

(Over Operating Free-Air Temperature, unless otherwise noted)†

Supply Voltage Range, $V_{CC}^{(1)}$	-0.5V to 4V
Input Voltage Range (D_{IN})	-0.5 to 6V
(Y or Z)	-0.5 to 4V
ESD Rating (HBM, 1.5K-Ohms, 100pF)	≥2KV
Continuous total power dissipation	See dissipation rating table
Storage Temperature Range	-65°C to 150°C
Lead Temperature 1.6 mm (1/16 inch) from case for 10 seconds	250°C

Notes:

† Stresses beyond those listed under "Absolute Maximum Ratings" may cause permanent damage to the device. These are stress ratings only, and functional operation of the device at these or any other conditions beyond those indicated under "Recommended Operating Conditions" is not implied. Exposure to Absolute-Maximum-Rated conditions for extended periods may affect device reliability.

1. All voltage values, except differential I/O bus voltages, are with respect to ground terminal.

Dissipation Rating Table

Package	$T_A \leq 25^\circ\text{C}$ Power Rating	Derating Factor Above $T_A = 25^\circ\text{C}^{\text{a}}$	$T_A = 85^\circ\text{C}$ Power Rating
T	385mW	3.1mW/°C	200mW

^aThis is the inverse of the junction-to-ambient thermal resistance when board-mounted (low-K) and with no air flow.

Recommended Operating Conditions

	Min.	Nom.	Max.	Units
Supply Voltage, V_{CC}	3.0	3.3	3.6	V
High-Level Input Voltage, V_{IH}	2		3.8	
Low-Level Input Voltage, V_{IL}			0.8	
Operating free-air temperature, T_A	-40		105	°C

Electrical Characteristics (Over Operating Free-Air Temperature, unless otherwise noted).

Symbol	Parameter	Test Conditions	Min.	Typ. ⁽¹⁾	Max.	Units
$ V_{OD} $	Differential output voltage magnitude	$R_L = 100$ ohms ('LV01)	247	350	454	mV
$\Delta V_{OD} $	Change in differential output voltage magnitude between logic states	$R_L = 50$ ohms ('LVB01) See Figure 1	-50		50	
$V_{OC(SS)}$	Steady-state common-mode output voltage	See Figure 2	1.125		1.375	V
$\Delta V_{OC(SS)}$	Change in steady-state common-mode output voltage between logic states		-50		50	mV
$V_{OC(PP)}$	Peak-to-peak common-mode output voltage			25	100	
I_{CC}	Supply current	$V_I = 0V$ or V_{CC} , No Load		2	5.5	mA
		$V_I = 0V$ or V_{CC} , $R_L = 100$ ohms ('LV01)		5.5	8	
		$V_I = 0V$ or V_{CC} , $R_L = 50$ ohms ('LVB01)		7.0	14	
I_{IH}	High-level input current	$V_{IH} = 5V$		2	20	μA
I_{IL}	Low-level input current	$V_{IL} = 0.8V$		2	10	
I_{OS}	Short-circuit output current	V_{ODOUT+} or $V_{ODOUT-} = 0V$	LV	3	10	mA
			LVB	6	20	
		$V_{OD} = 0V$	LV		10	
			LVB		20	
$I_{O(OFF)}$	Power-off output current	$V_{CC} = 0V$, $V_O = 3.6V$			± 1	μA
C_{IN}	Input capacitance			3		pF

Note:

- All typical values are at 25°C and with a 3.3V

Switching Characteristics, $V_{CC} = 3V$ to $3.6V$ (Over Operating Free-Air Temperature, unless otherwise noted).

Symbol	Parameter	Test Conditions	Min	Typ. ⁽¹⁾	Max.	Units
t_{PLH}	Propagation delay time, low-to-high level output	PI90LV01, $R_L = 100\text{-ohms}$, $C_L = 10\text{pF}$ PI90LVB01, $R_L = 50\text{-ohms}$, $C_L = 10\text{pF}$ See Figure 3		1.5	2.7	ns
t_{PHL}	Propogation delay time, high-to-low level output			1.8	2.7	
t_r	Transition, low-to-high (PI90LV01)			0.6	1.5	
	Transition, low-to-high (PI90LBV01)			0.5	1.4	
t_f	Transition, high-to-low (PI90LV01)			0.7	1.5	
	Transition, high-to-low (PI90LBV01)			0.6	1.4	
$t_{sk(p)}$	Pulse skew ($ t_{PHL} - t_{PLH} $) ⁽²⁾			0.3	-	

Notes:

1. All typical values are at 25°C and with a 3.3V supply
2. $t_{sk(p)}$ is the magnitude of the time difference between the high-to-low and low-to-high propagation delay times at an output
3. f_{max} generator input conditions: 50% duty cycle, 0V to 3V. Output criteria: 45% to 55% duty cycle, $V_{OD} = 250\text{mV}$

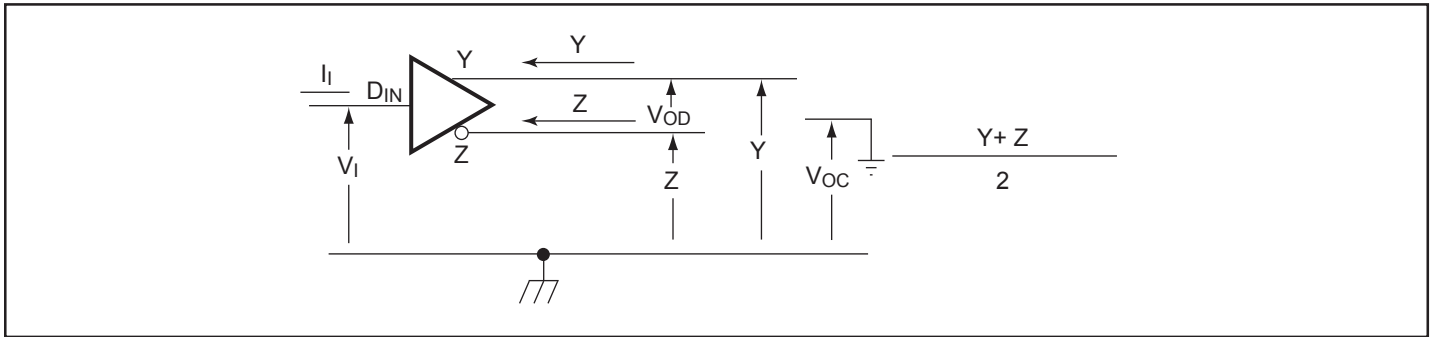
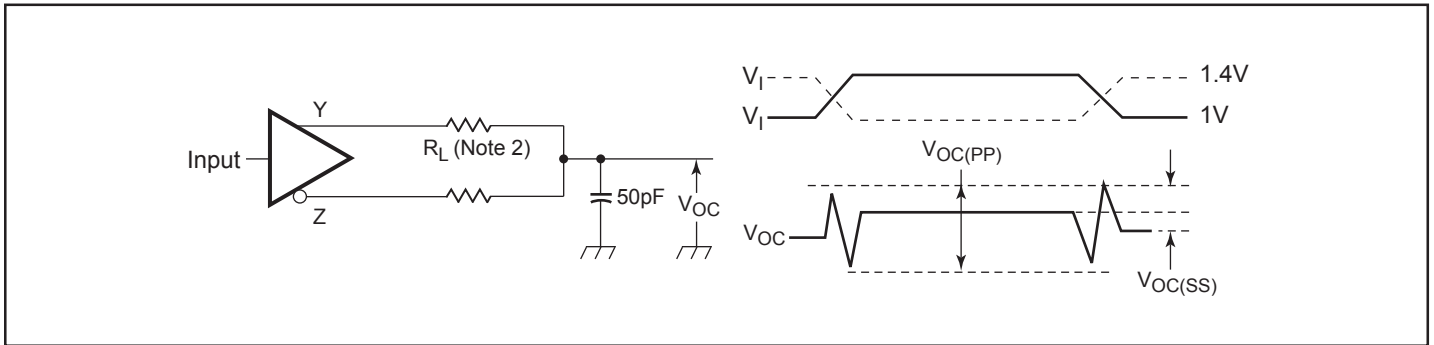
Parameter Measurement Information

Figure 1. Driver Voltage and Current Definitions

Figure 2. Test Circuit and Definitions for the Driver Common-Mode Output Voltage
Note:

1. All input pulses are supplied by a generator having the following characteristics: t_r or $t_f \leq 1$ ns, Pulse Repetition Rate (PRR) = 0.5 Mpps, Pulse width = 500 ± 10 ns. C_L includes instrumentation and fixture capacitance within 0.06mm of the D.U.T. The measurement of $V_{OC(PP)}$ is made on test equipment with a -3dB bandwidth of at least 300MHz.

Parameter Measurement Information

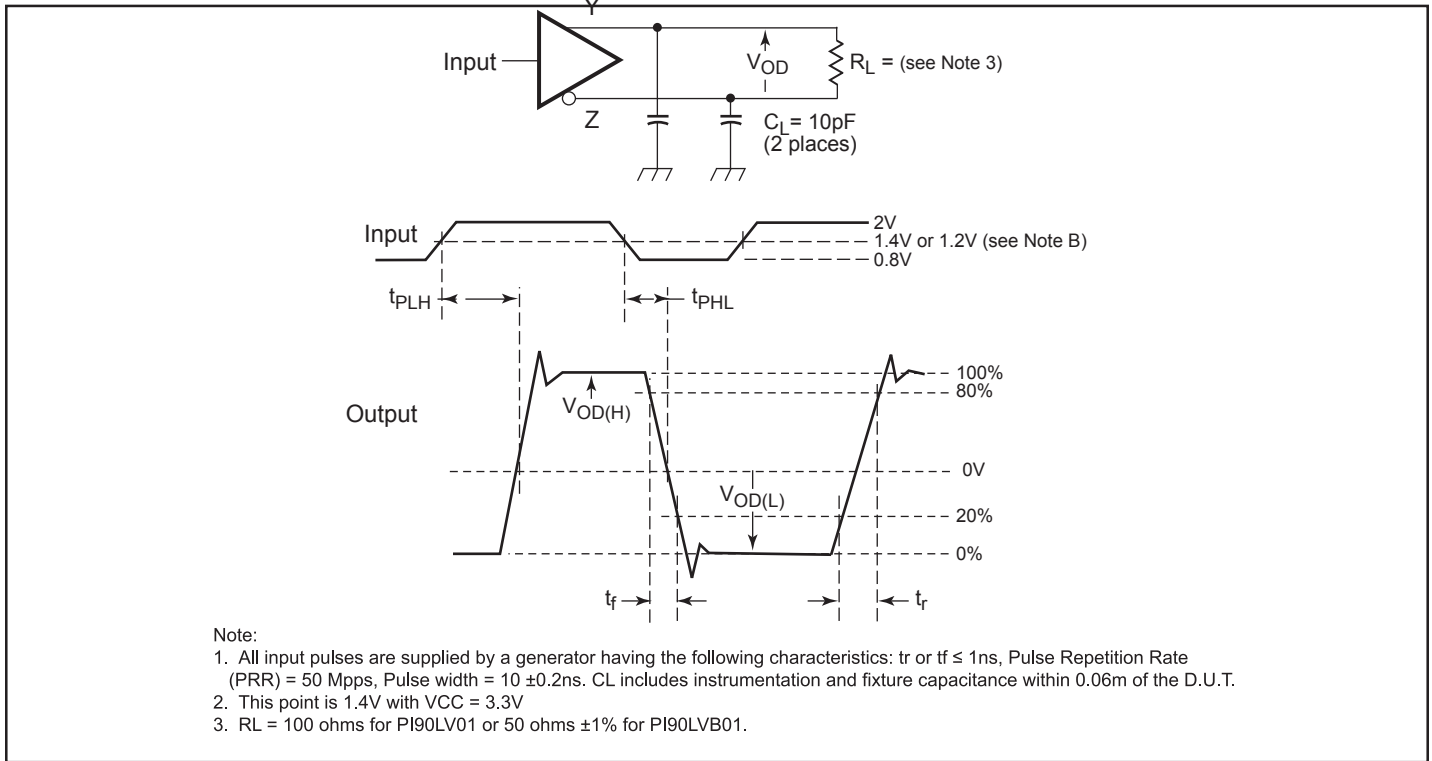
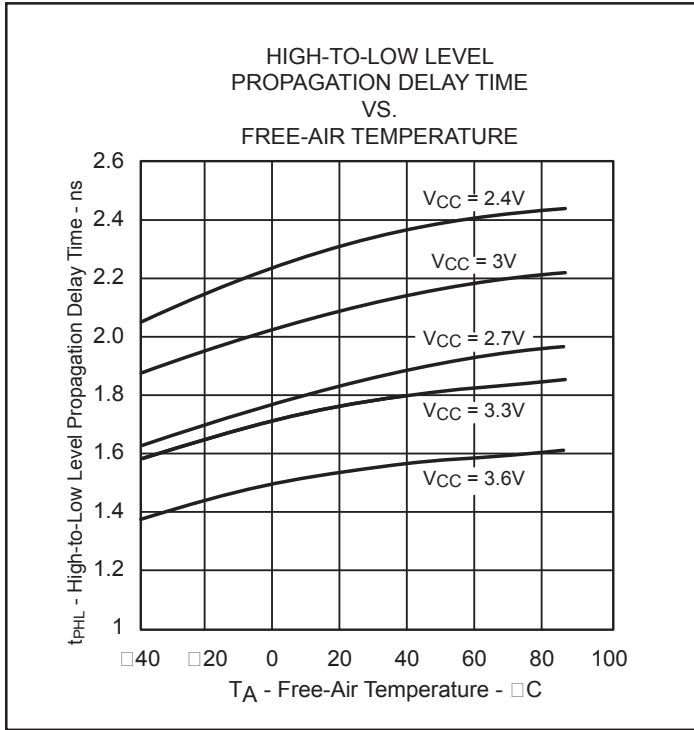
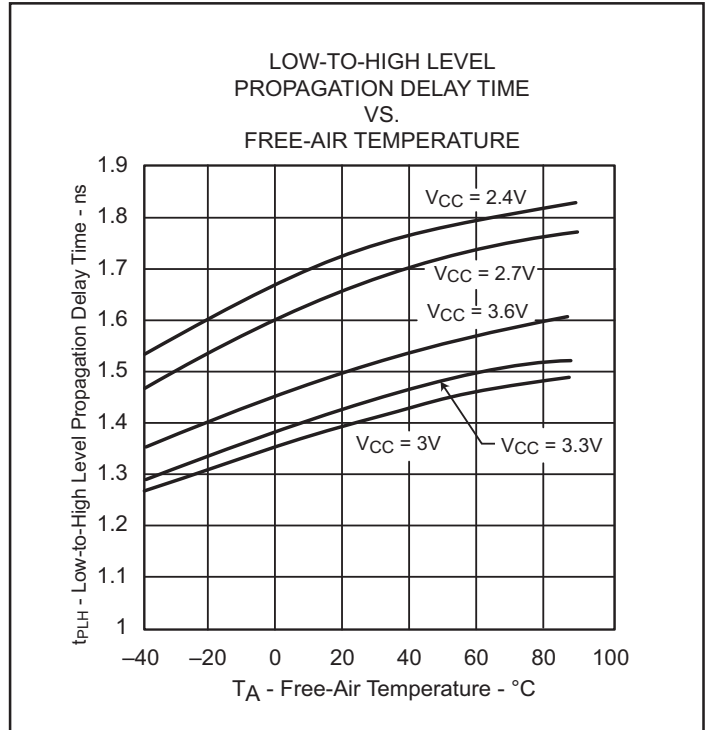
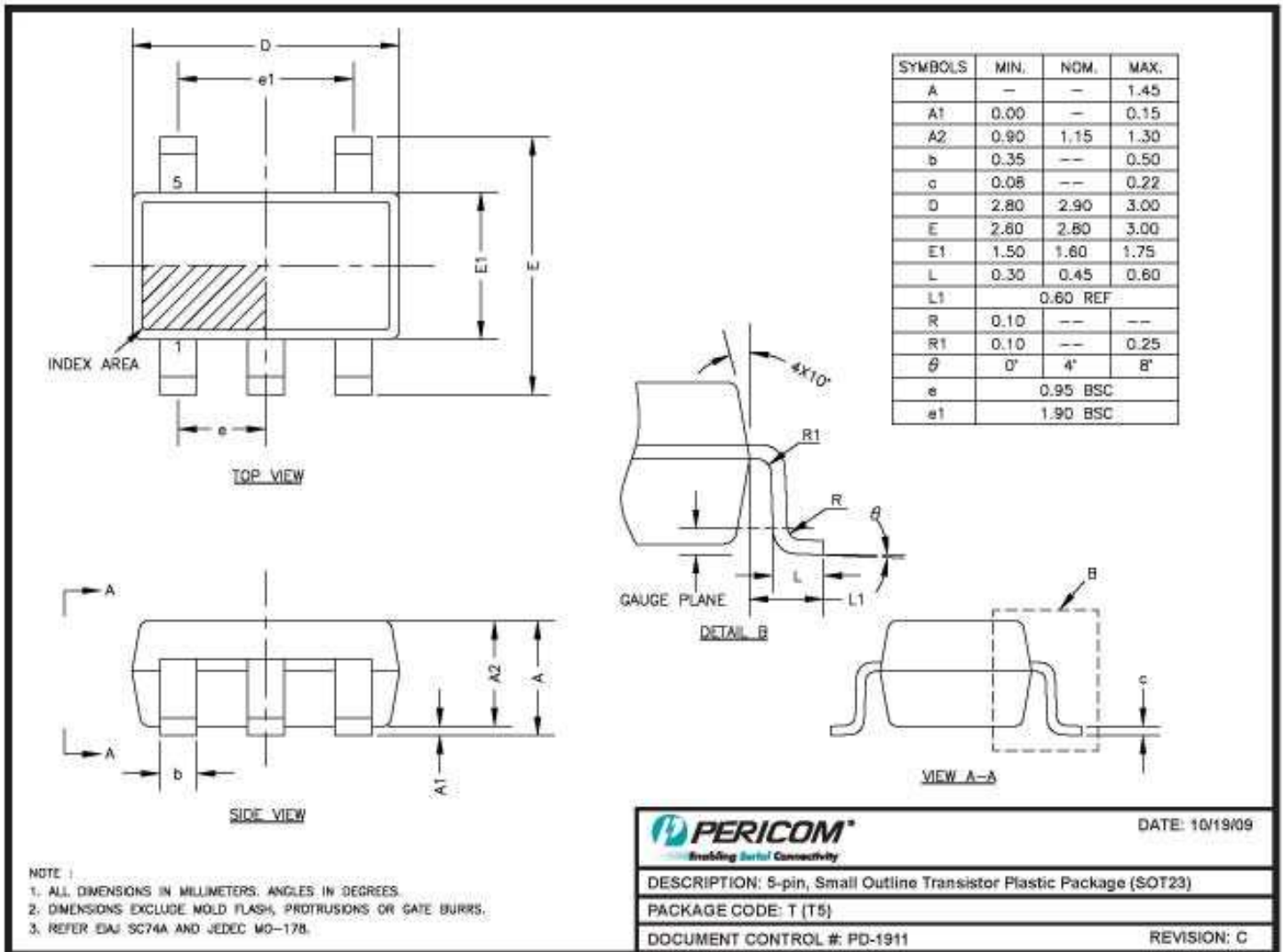

Figure 3. Test Circuit, Timing, & Voltage Definitions for the Differential Output Signal

Figure 5.

Figure 6



09-0130

Note:

1. For latest package info, please check: <http://www.pericom.com/products/packaging/mechanicals.php/>

Ordering Information

Ordering Code	Package Code	Package Description	Top Marking
PI90LV01TEX	T	Pb-free & Green, 5-pin, SOT23	1
PI90LVB01TEX	T	Pb-free & Green, 5-pin, SOT23	2

Notes:

1. Thermal characteristics can be found on the company web site at www.pericom.com/packaging/
2. E = Pb-free and Green
3. X = Tape and reel