
3.3V LVDS High-Speed Differential Line Driver and Receiver
Features

- Signaling Rates >660 Mbps (330 MHz)
- Single 3.3V Power Supply Design
- Driver:
 - $\pm 350\text{mV}$ Differential Swing into a 100-ohm load
 - Propagation Delay of 1.5ns Typ.
 - Low Voltage TTL (LVTTL) Inputs are 5V Tolerant
- Receiver:
 - Accepts $\pm 50\text{mV}$ (min.) Differential Swing with up to 2.0V ground potential difference
 - Propagation Delay of 3.3ns Typ.
 - Low Voltage TTL (LVTTL) Outputs
 - Open, Short, and Terminated Fail Safe
- Industrial Temperature Operating Range: -40°C to 85°C
- Meets or Exceeds IEEE 1596.3 SCI Standard
- Meets or Exceeds ANSI/TIA/EIA-644 LVDS Standard
- Bus-Terminal ESD exceeds 12kV
- Packaging (Pb-free & Green available):
 - 8-pin SOIC or MSOP

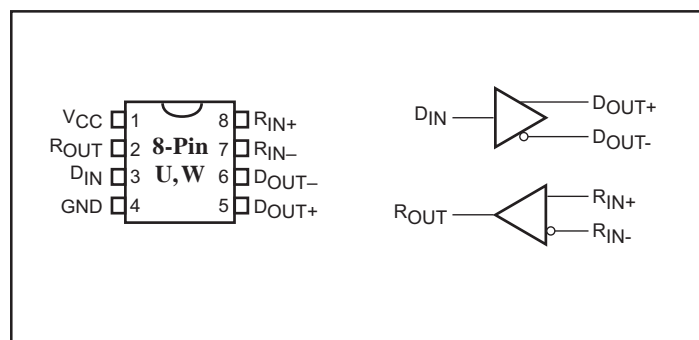
Description

The PI90LV179 is a differential line driver and receiver (transceiver) that is compliant with the IEEE 1596.3 SCI and ANSI/TIA/EIA-644 LVDS standards. This device uses low-voltage differential signaling (LVDS) to achieve data rates in excess of 660 Mbps while being less susceptible to noise than single-ended transmission.

The driver translates a low-voltage TTL/CMOS input into a low-voltage (350mV typical) differential output signal. The receiver translates a differential 350mV input signal to a 3V CMOS output level.

Applications

Applications include point-to-point and multidrop baseband data transmission over a controlled impedance media of approximately 100 ohms. These include intra-system connections via printed circuit board traces or cables, hubs and routers for data communications; PBXs, switches, repeaters and base stations for telecommunications and other applications such as digital cameras, printers and copiers.

PI90LV179


Function Tables
PI90LV179 Receiver

Inputs	Output
$V_{ID} = V_{RIN+} - V_{RIN-}$	R_{OUT}
$V_{ID} \geq 50mV$	H
$-50mV < V_{ID} < 50mV$?
$V_{ID} \leq -50mV$	L
open	H

PI90LV179 Driver

Input	Output	
	D_{OUT+}	D_{OUT-}
D_{IN}		
L	L	H
H	H	L
open	L	H

Notes:

H = High Level, L = Low Level, ? = Indeterminate,
 Z = High-Impedance, X = Don't Care

Pin Descriptions

Name	Description
D_{IN}	TTL/CMOS driver input pins
D_{OUT+}	Non-inverting driver output pins
D_{OUT-}	Inverting driver output pins
R_{OUT}	TTL/CMOS receiver output pins
R_{IN+}	Non-inverting receiver input pins
R_{IN-}	Inverting receiver input pins
V_{ID}	Input Differential Signal Voltage
GND	Ground pin
V_{CC}	Positive power supply pin, +3.3V ±10%

Absolute Maximum Ratings

Supply Voltage (V_{CC})	-0.5V to +4.0V
Driver	
Input Voltage (D_{IN})	-0.3V to ($V_{CC} + 0.3V$)
Output Voltage (D_{OUT+}, D_{OUT-})	-0.3V to +3.9V
Short Circuit Duration (D_{OUT+}, D_{OUT-})	Continuous
Receiver	
Input Voltage (R_{IN+}, R_{IN-})	-0.3V to +3.9V
Output Voltage (R_{OUT})	-0.3V to ($V_{CC} + 0.3V$)
Storage Temperature Range	-65°C to +150°C
Lead Temperature Range Soldering (4s)	+260°C
Maximum Junction Temperature	+150°C
ESD Rating	>12kV

Recommended Operating Conditions

	Min.	Typ.	Max.	Units
Supply Voltage (V_{CC})	3	3.3	3.6	V
High Level Input Voltage, V_{IH}	2			
Low Level Input Voltage, V_{IL}			0.8	
Magnitude of Differential Input Voltage V_{ID}	0.1		0.6	
Common-mode Input Voltage, V_{IC} (Fig 5)	$ V_{ID} /2$		2.4	
			$- V_{ID} /2$	
			$V_{CC} - 0.8$	
Operating Free Air Temperature T_A	-40		85	°C

Electrical Characteristics (Over recommended operating conditions unless otherwise noted).

Parameter	Test Condition	Min.	Typ. [†]	Max.	Units
I _{CC} * Supply Current	No receiver load, Driver R _L = 100 ohms		8.0	10.8	mA

[†]All typical values are at 25°C with a 3.3V supply

*_I_{CC} measured with all TTL input. V_{IN} = V_{CC} or GND.

Electrical Characteristics (Over recommended operating conditions unless otherwise noted).

Parameter		Test Conditions	Min.	Typ.	Max.	Units
V _{OD}	Differential output voltage magnitude	R _L = 100 ohms See Figures 1 and 2	247	390	470	mV
Δ V _{OD}	Change in differential output voltage magnitude between logic states		-50		50	
V _{OC(SS)}	Steady-state common-mode output voltage	See Figure 3	1.125	1.25	1.375	V
ΔV _{OC(SS)}	Change in steady-state common-mode output voltage between logic states		-50		50	mV
V _{OC(PP)}	Peak-to-peak common-mode output voltage			50	150	
I _{IH}	High-level input current	D _{IN} V _{IH} = 5V		2	20	μA
I _{IL}	Low-level input current	D _{IN} V _{IL} = 0.8V		2	10	
I _{OS}	Short-circuit output current	V _{OY} or V _{OZ} = 0V		-6	-9	mA
		V _{OD} = 0V		-8	-11	
I _{OZ}	High-impedance output current	V _{OD} = 600mV			±1	μA
		V _O - 0V or V _{CC}			±1	
I _{O(OFF)}	Power-off output current	V _{CC} = 0V, V _O = 3.6V			±1	
C _{IN}	Input capacitance			7		pF

Receiver Electrical Characteristics (Over recommended operating conditions unless otherwise noted).

Parameter		Test Conditions	Min.	Typ.	Max.	Units
V _{ITH+}	Positive-going differential input voltage threshold	See Figures 5 & Table 1			50	mV
V _{ITH-}	Negative-going differential input voltage threshold		-50			
V _{OH}	High-level output voltage	I _{OH} = -8mA	2.4			V
V _{OL}	Low-level output voltage	I _{OL} = 8mA			0.4	V
I _I	Input current (R _{IN+} or R _{IN-})	V _I = 0	-2	-11	-20	μA
		V _I = 2.4V	-1.2	-3		
I _{I(OFF)}	Power-off input current (R _{IN+} or R _{IN-})	V _{CC} = 0			±20	
I _H	High-level input current (enables)	V _{IH} = 2V			±10	
I _L	Low-level input current (enables)	V _{IL} = 0.8V			±10	
I _{OZ}	High-impedance output current	V _O = 0 or 5V			±10	
C _I	Input capacitance			5		

† All typical values are at 25°C with a 3.3V supply

Driver Switching Characteristics (Over recommended operating conditions unless otherwise noted).

Parameter		Test Conditions	Min.	Typ. [†]	Max.	Units
t _{PLH}	Propagation delay time, low-to-high-level output	R _L = 100 ohms C _L = 10pF See Figure 2		1.9	2.5	ns
t _{PHL}	Propagation delay time, high-to-low-level output			1.9	2.5	
t _r	Differential output signal rise time			0.6	1.1	
t _f	Differential output signal fall time			0.6	1.1	
t _{sk(p)}	Pulse skew (t _{PHL} - t _{PLH})				270	ps
t _{sk(pp)}	Part-part-part skew**				0.9	ns
t _{PZH}	Propagation delay time, high-impedance-to-high-level output	See Figure 7		2.7	4	
t _{PZL}	Propagation delay time, high-impedance-to-low-level output			1.8	4	
t _{PHZ}	Propagation delay time, high-level-to-high-impedance output			3.0	4	
t _{PLZ}	Propagation delay time, low-level-to-high-impedance output			3.0	4	

† All typical values are at 25°C with a 3.3V supply.

** t_{sk(pp)}: magnitude of difference in propagation delay times between any specific terminals of two devices (all things being equal).

Receiver Switching Characteristics (Over recommended operating conditions unless otherwise noted).

Parameter		Test Conditions	Min.	Typ. [†]	Max.	Units
t _{PLH}	Propagation delay time, low-to-high-level output	C _L = 10pF See Figure 6		2.0	3.1	ns
t _{PHL}	Propagation delay time, high-to-low-level output			2.2	3.1	
t _{sk(pp)**}	Part-part-part skew**				1.3	
t _{sk(p)}	Pulse skew (t _{PHL} – t _{PLH})			300	500	ps
t _r	Output signal rise time			0.9	1.5	
t _f	Output signal fall time			1.0	1.8	
t _{PZH}	Propagation delay time, high-level-to-high-impedance output	See Figure 7		1.5	3.1	ns
t _{PZL}	Propagation delay time, low-level-to-low-impedance output			4.0	6.0	
t _{PHZ}	Propagation delay time, high-impedance-to-high-level output			2.5	3.5	
t _{PLZ}	Propagation delay time, low-impedance-to-high-level output			6.0	7.6	

[†]All typical values are at 25°C with a 3.3V supply

**t_{sk(pp)}: magnitude of difference in propagation delay times between any specific terminals of two devices (all things being equal)

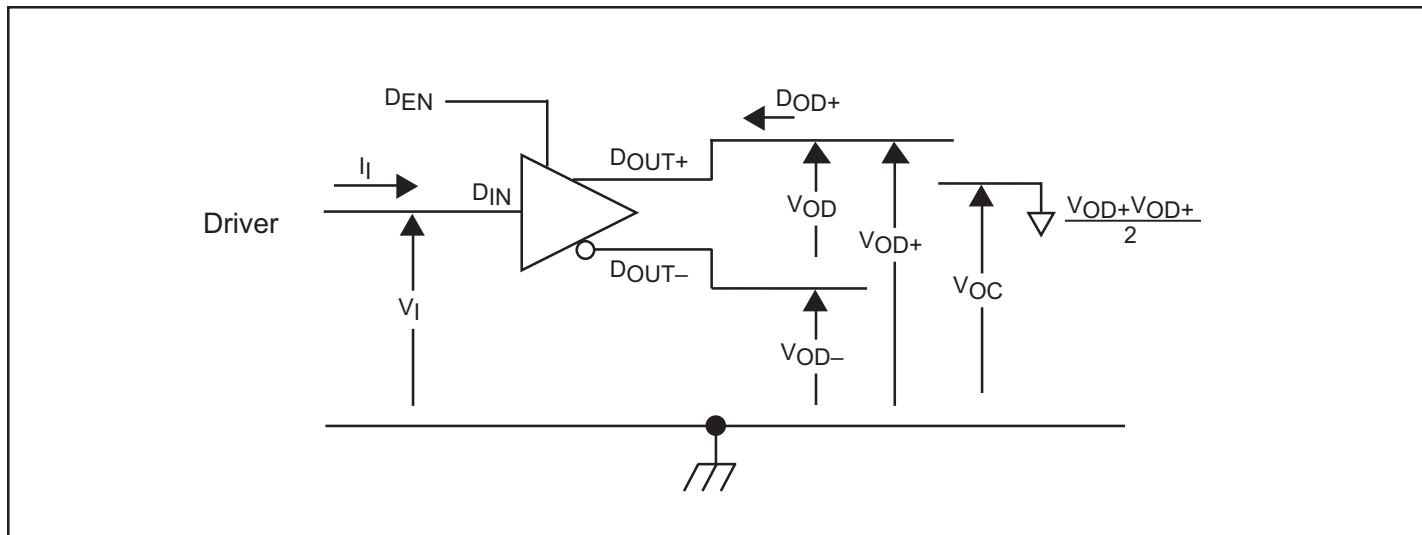
Parameter Measurement Information


Figure 1. Driver Voltage and Current Definitions

Parameter Measurement Information

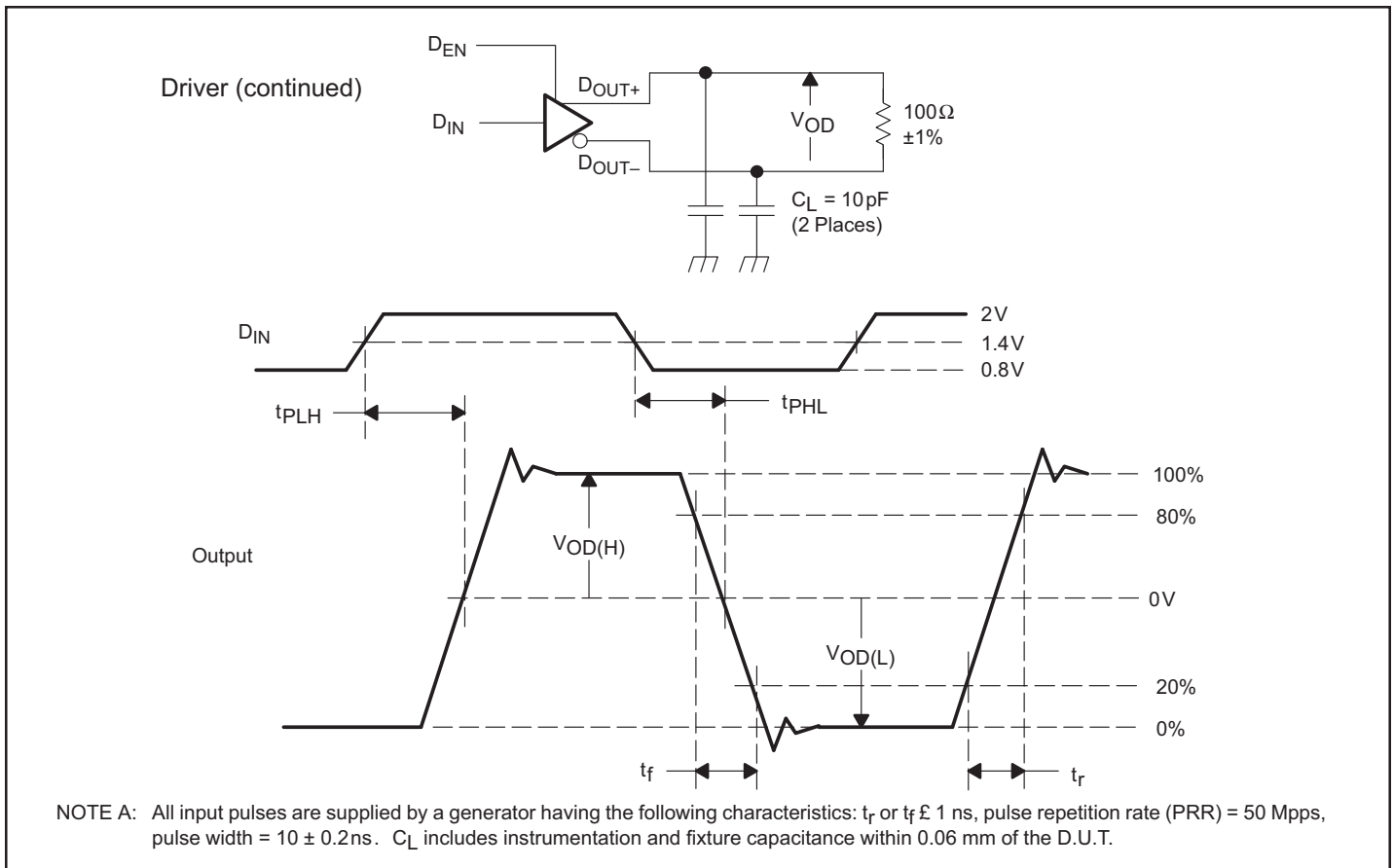


Figure 2. Test Circuit, Timing, and Voltage Definitions for the Differential Output Signal

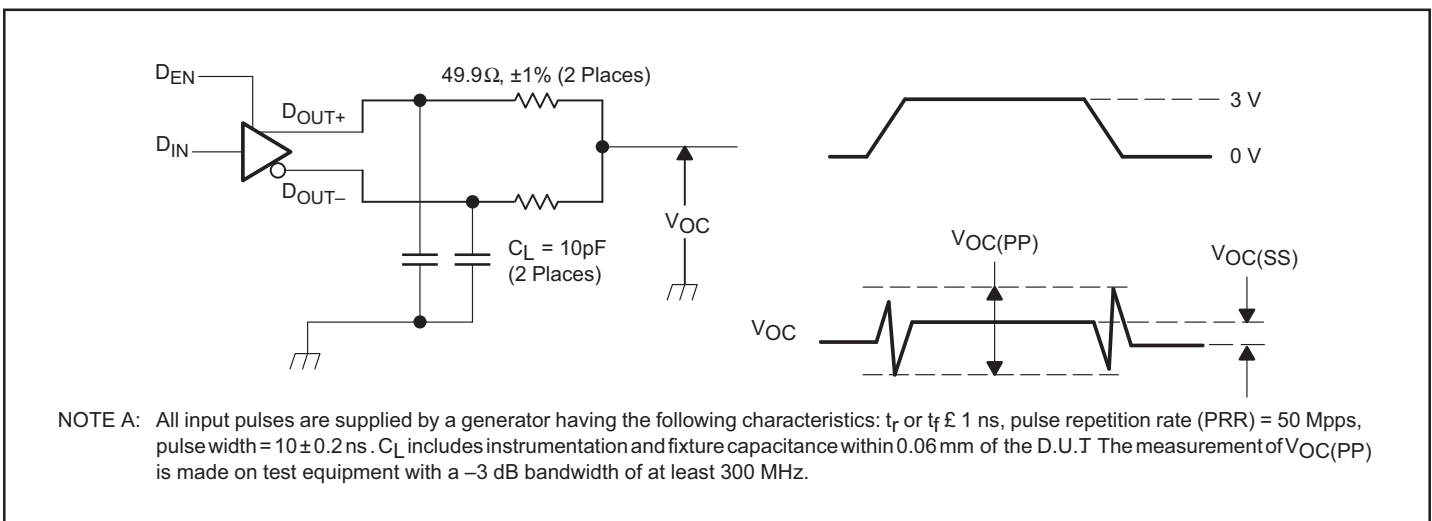


Figure 3. Test Circuit and Definitions for the Driver Common-Mode Output Voltage

Parameter Measurement Information (continued)

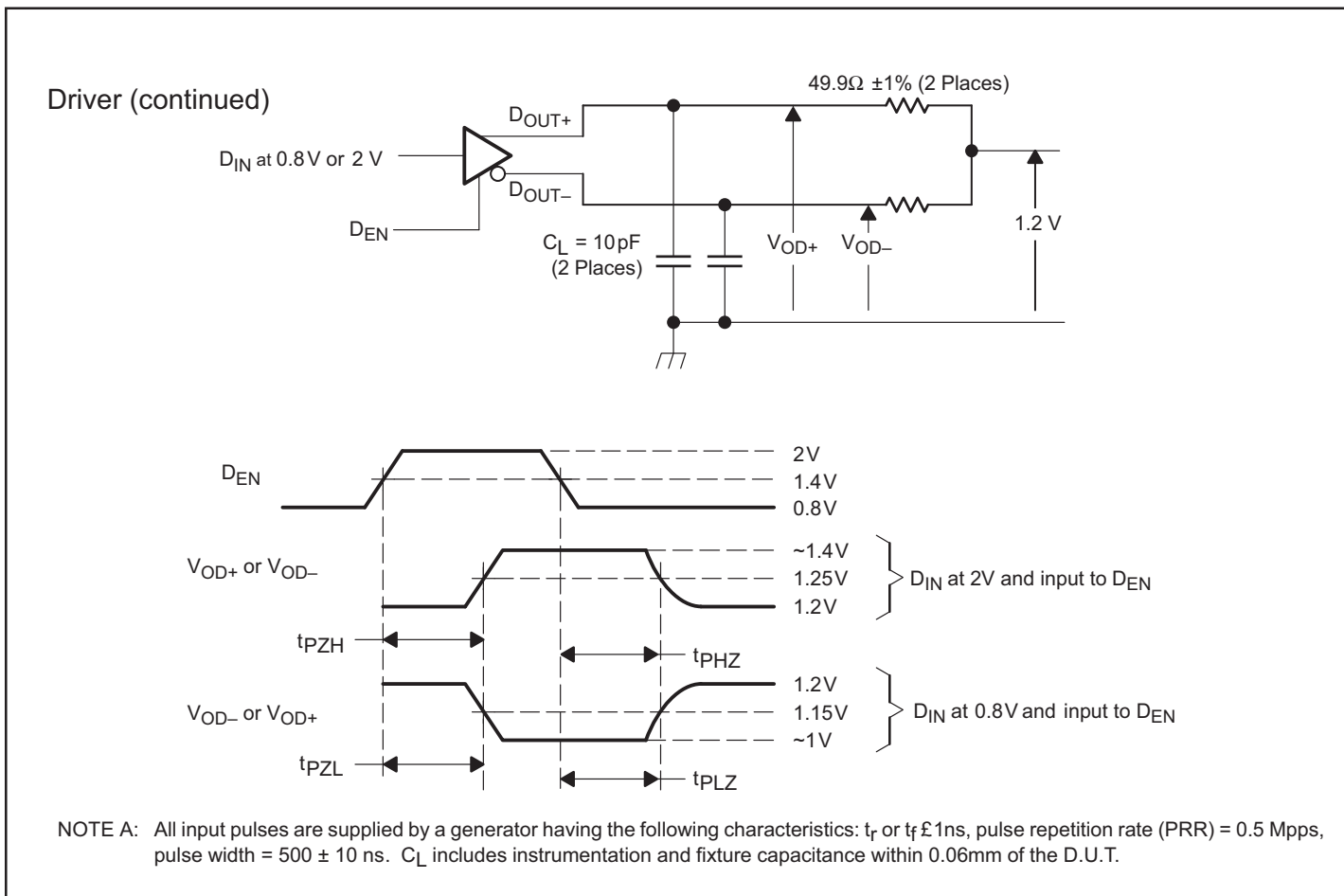
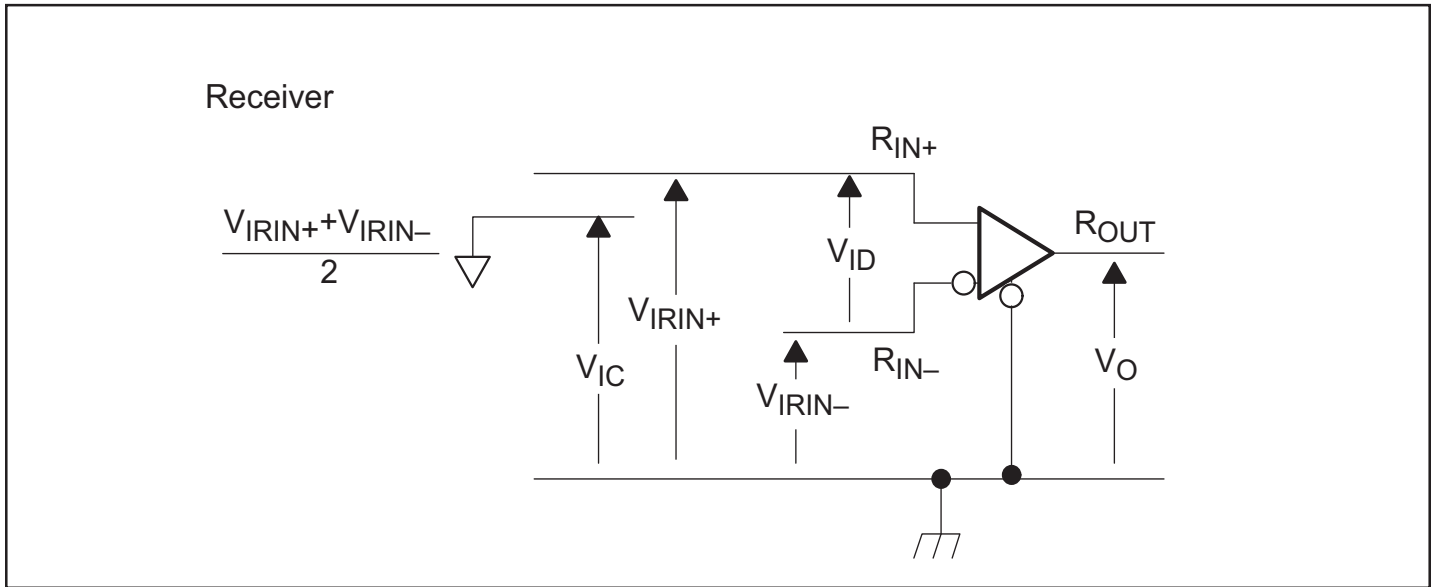


Figure 4. Enable and Disable Timing Circuit and Definitions

Parameter Measurement Information (continued)

Figure 5. Receiver Voltage Definitions
Table 1. Receiver Minimum and Maximum Input Threshold Test Voltages

APPLIED VOLTAGES (V)		RESULTING DIFFERENTIAL INPUT VOLTAGE (mV)	RESULTING COMMON-MODE INPUT VOLTAGE (V)
V_{IRIN+}	V_{IRIN-}	V_{ID}	V_{IC}
1.225	1.175	50	1.2
1.175	1.225	-50	1.2
2.375	2.325	50	2.35
2.325	2.375	-50	2.35
0.1	0	50	0.05
0	0.05	-50	0.05
1.5	0.9	600	1.2
0.9	1.5	-600	1.2
2.4	1.8	600	2.1
1.8	2.4	-600	2.1
0.6	0	600	0.3
0	0.6	-600	0.3

Parameter Measurement Information (continued)

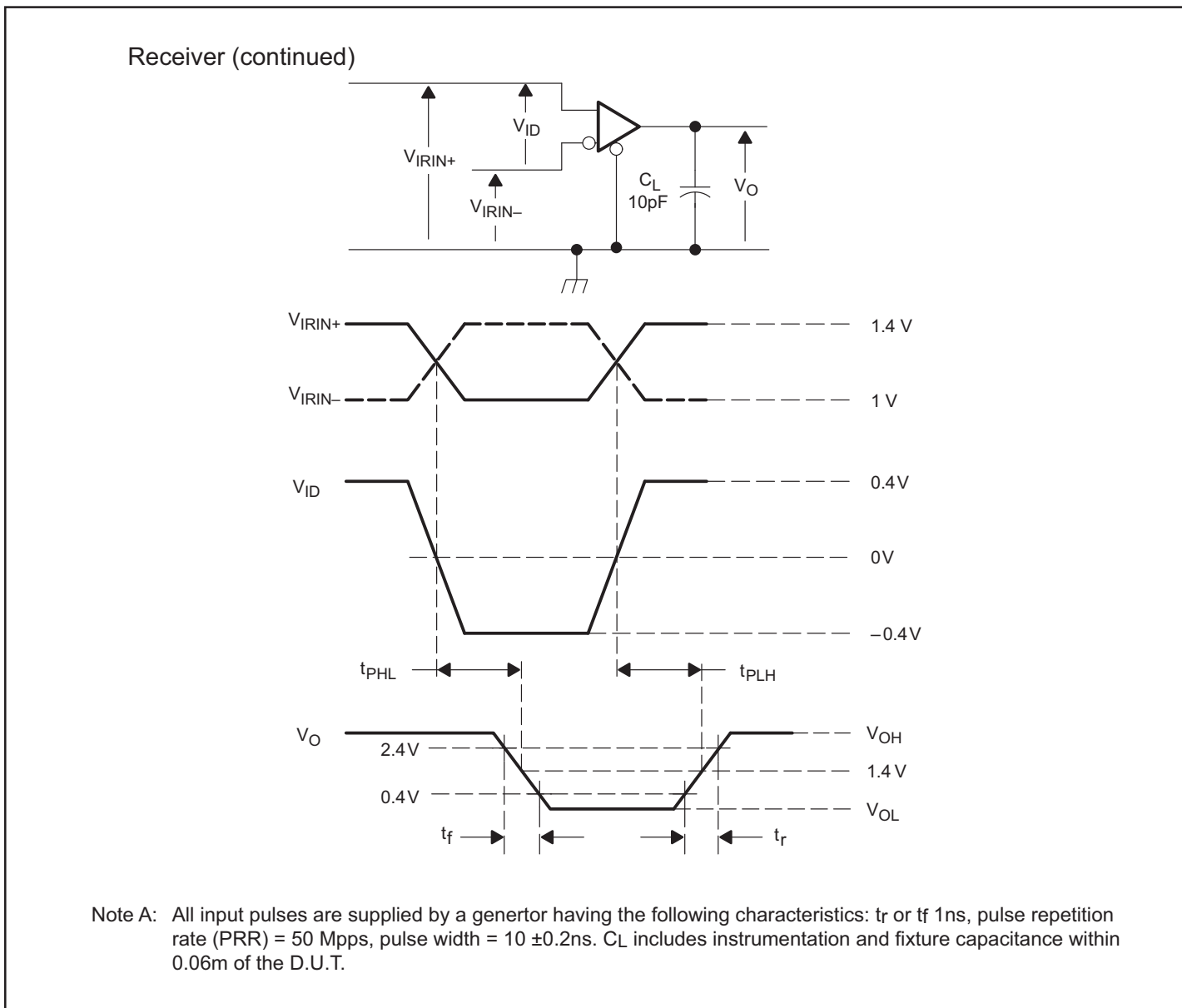
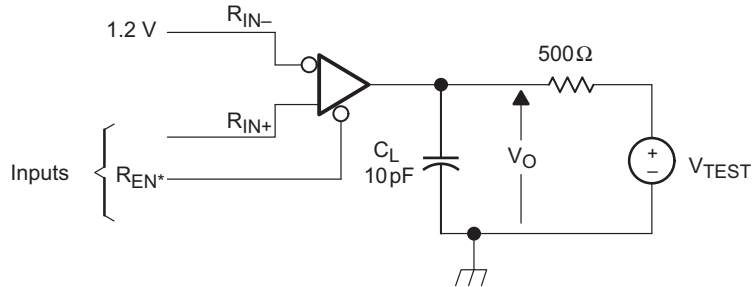


Figure 6. Timing Test Circuit and Waveforms

Parameter Measurement Information

Receiver (continued)



NOTE A: All input pulses are supplied by a generator having the following characteristics: t_r or t_f 1ns, pulse repetition rate (PRR) = 0.5 Mpps, pulse wide = 500 ± 10 ns. C_L includes instrumentation and fixture capacitance within 0.06m of the D.U.T.

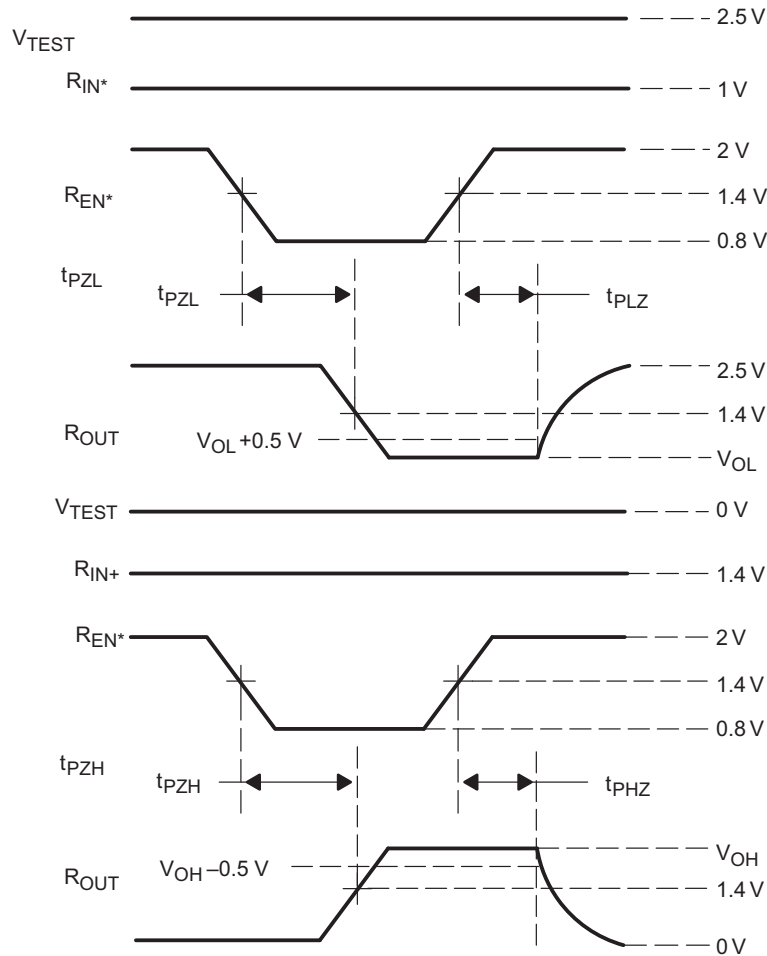
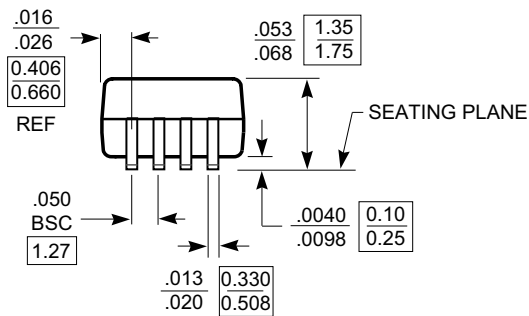
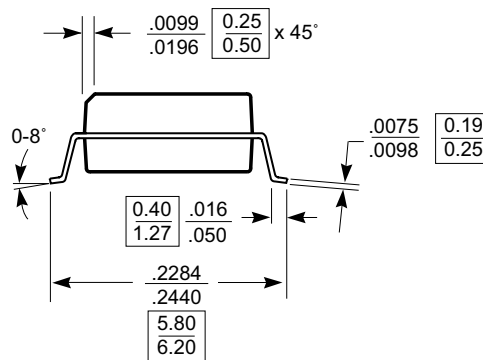
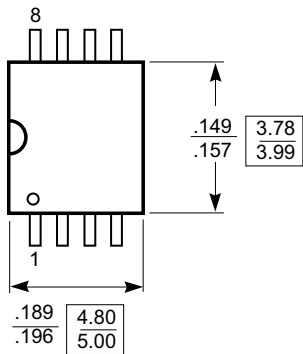


Figure 7. Enable/Disable Time Test Circuit and Waveforms

Packaging Mechanical: 8-Pin SOIC (W)
DOCUMENT CONTROL NO.
PD - 1001
REVISION: F
DATE: 03/09/05


X.XX DENOTES DIMENSIONS
X.XX IN MILLIMETERS

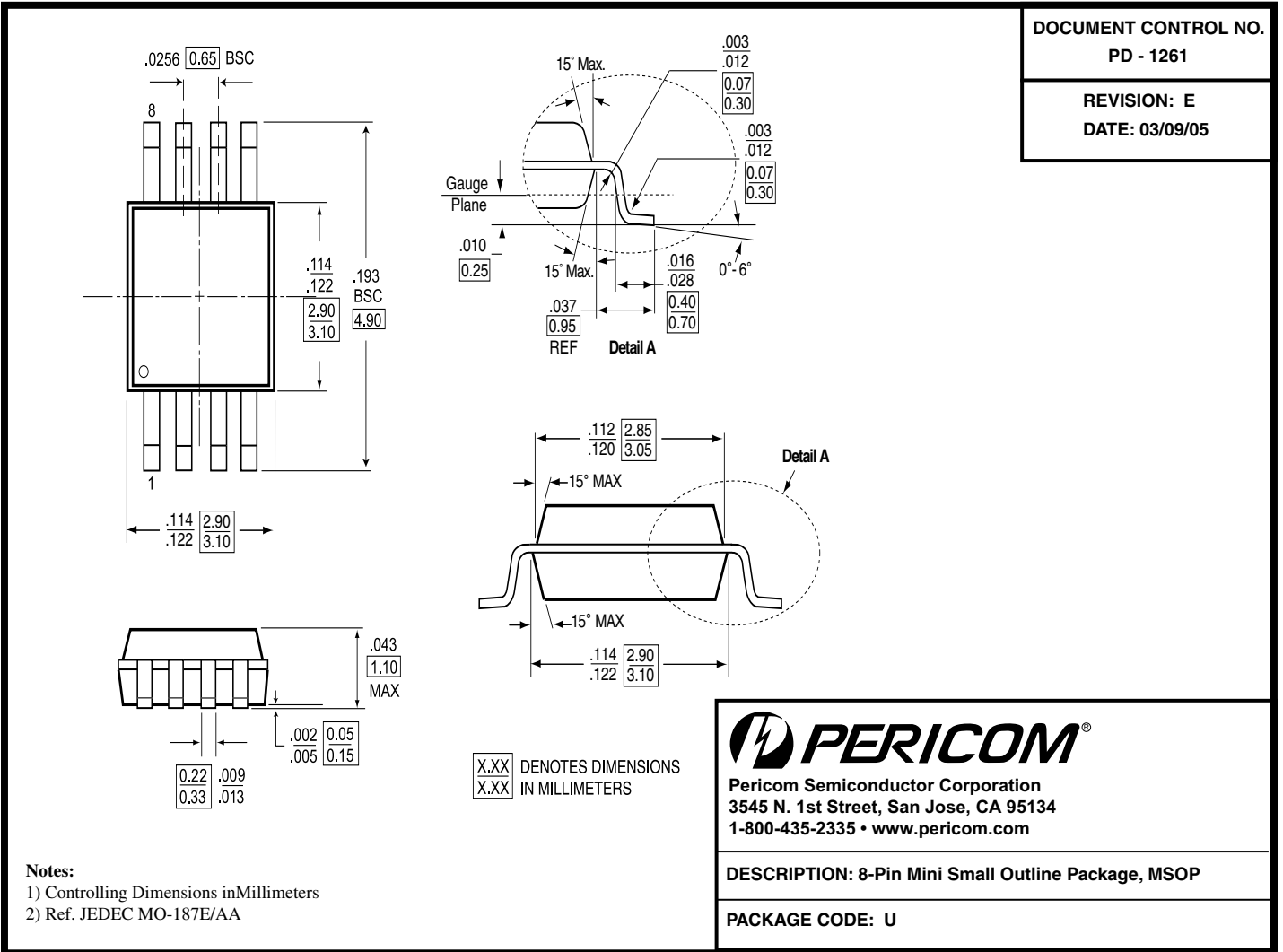
Notes:

- 1) Controlling dimensions in millimeters.
- 2) Ref: JEDEC MS-012D/AA



Pericom Semiconductor Corporation
 3545 N. 1st Street, San Jose, CA 95134
 1-800-435-2335 • www.pericom.com

DESCRIPTION: 8-Pin, 150-Mil Wide, SOIC
PACKAGE CODE: W

Packaging Mechanical: 8-Pin MSOP (U)

Ordering Information

Ordering Code	Package Code	Package Description
PI90LV179UE	U	Pb-free & Green, 8-pin MSOP
PI90LV179WE	W	Pb-free & Green, 8-pin SOIC

Note:

- Thermal characteristics can be found on the company web site at www.pericom.com/packaging/