

## 2:1 Mux/DeMux High Bandwidth (> 5 Gbps) HDMI 1.3 Compliant Signal Switch

### Features

- 4-Differential Channel 2:1 Mux/DeMux
- HDMI 1.1, 1.2, and 1.3 compatible
- Allowable Data Rate: > 5.0 Gbps
- Supports both AC coupled and DC coupled signals
- Switching speed: 4ns
- Isolation: -40dB @ 2.0 Gbps
- Crosstalk: -31dB @ 2.0 Gbps
- ESD: Data bits @ 8kV contact, select bit @ 2kV HBM
- Low bit-to-bit skew
- Enable/Disable Time: 9ns
- Bidirectional
- Packaging (Pb-free & Green):
  - 42-pin TQFN (ZH42)
  - 48-pin BQSOP (B48)

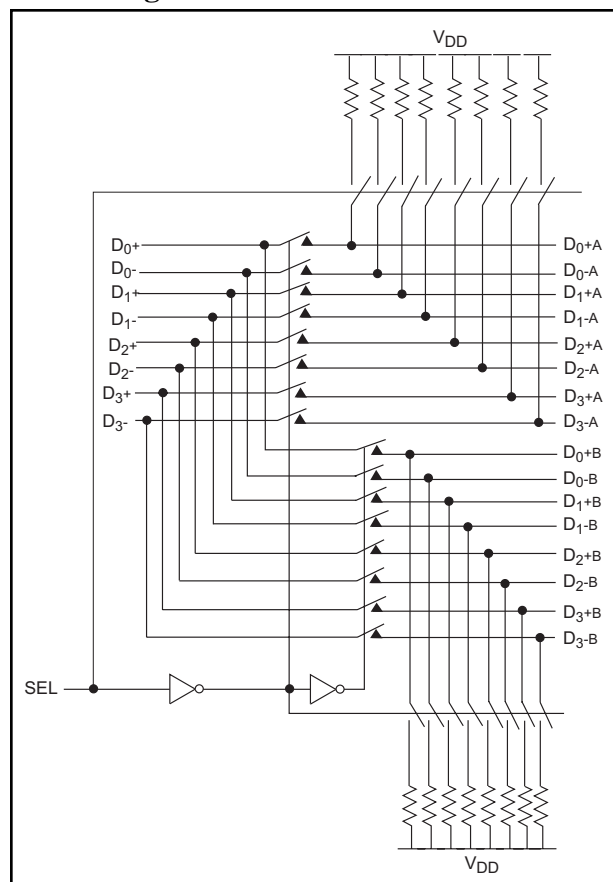
### Description

Pericom Semiconductor's PI3HDMI series of switch circuits are targeted for high-resolution video networks that are based on DVI/HDMI standards, and TMDS signal processing. The PI3HDMI412FT-A is an 8- to 4-Channel Mux/DeMux Switch. The device multiplexes differential signals to one of two corresponding outputs. The switch is bidirectional and offers little or no attenuation of the high-speed signals at the outputs. It is designed for low bit-to-bit skew and high channel-to-channel noise isolation.

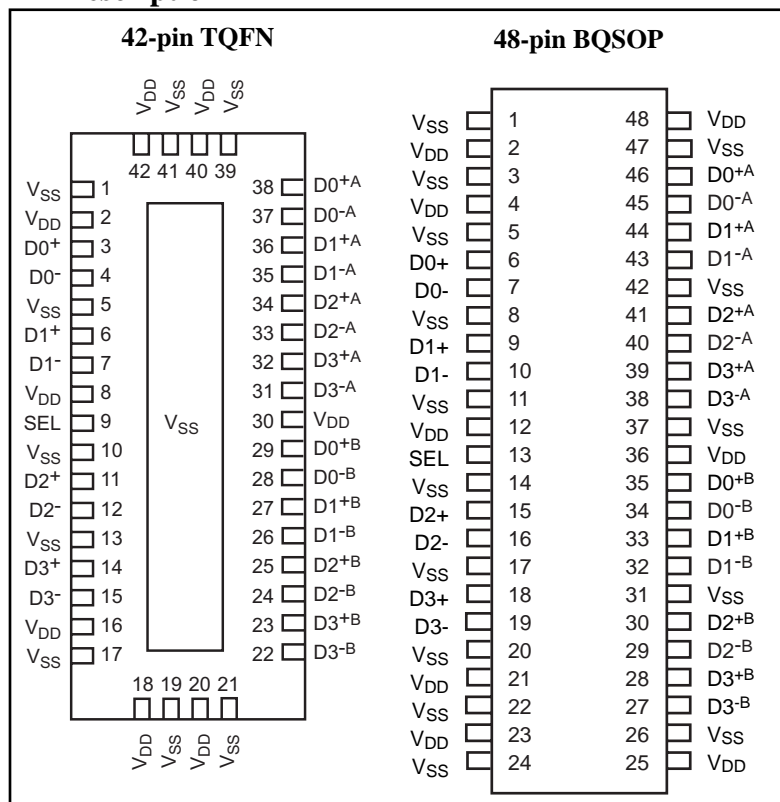
The allowable data rate of 5.0Gbps provides the resolution required by the next generation HDTV and PC graphics. Three differential channels are used for data (video signals for DVI or audio/video signals for HDMI), and one differential channel is used for Clock for decoding the TMDS signals at the outputs.

Due to its integrated pull-up resistors, the product has been designed specifically for applications where the part is used as a 2 to 1 mux, not 1 to 2 demux. Therefore, Pericom only recommends the part to be used as a 2 to 1 mux when dealing with HDMI signals. Even though the passive circuitry does not eliminate the bi-directional functionality, it is not ideal when used with HDMI signals. If DVI are used, either direction can be used.

### Block Diagram



### Pin Description



### Pin Description

Pin # (BQSOP)	Pin # (TQFN)	Pin Name	Description
2, 4, 12, 21, 23, 25, 36, 48	2, 8, 16, 18, 20, 30, 40, 42	V <sub>DD</sub>	+ Power supply 3.30V
1, 3, 5, 8, 11, 14, 17, 20, 22, 24, 26, 31, 37, 42, 47	1, 5, 10, 13, 17, 19, 21, 39, 41	V <sub>SS</sub>	- Power supply
13	9	SEL	Select pin, see truth table
6, 7, 9, 10, 15, 16, 18, 19, 27-30, 32-35, 38-41, 43-36	3, 4, 6, 7, 11, 12, 14, 15, 22-29, 31-38	Dx <sup>+/-x</sup> + CLK <sup>+/-x</sup>	Data + Clk bits for TMDS signal

### Truth Table

SEL	Function
L	Dx → Dx <sup>A</sup> + Dx <sup>B</sup> pullups are active
H	Dx → Dx <sup>B+</sup> + Dx <sup>A</sup> pullups are active

### Maximum Ratings

(Above which useful life may be impaired. For user guidelines, not tested.)

Storage Temperature.....	-65°C to +150°C
Supply Voltage to V <sub>SS</sub> Potential.....	-0.5V to +2.5V
DC Input Voltage .....	0V to V <sub>DD</sub> +0.5V
DC Output Current.....	120mA

**Note:** Stresses greater than those listed under MAXIMUM RATINGS may cause permanent damage to the device. This is a stress rating only and functional operation of the device at these or any other conditions above those indicated in the operational sections of this specification is not implied. Exposure to absolute maximum rating conditions for extended periods may affect reliability.

### DC Power Supply Characteristics

Parameter	Description	Min.	Max.	Units
V <sub>DD</sub>	Positive Power Supply	3.0	3.6	V
V <sub>SS</sub>	Negative Power Supply	1.5	1.6	V

### DC Electrical Characteristics for Switching over Operating Range (T<sub>A</sub> = -40°C to +85°C)

Parameter	Description	Test Conditions <sup>(1)</sup>	Min.	Typ. <sup>(2)</sup>	Max.	Units
V <sub>IH</sub> <sup>(3)</sup>	Input HIGH Voltage	Guaranteed HIGH level	0.65(V <sub>DD</sub> -V <sub>SS</sub> )+V <sub>SS</sub>			V
V <sub>IL</sub> <sup>(3)</sup>	Input LOW Voltage	Guaranteed LOW level	-0.5+V <sub>SS</sub>		0.35(V <sub>DD</sub> -V <sub>SS</sub> )+V <sub>SS</sub>	
V <sub>IK</sub>	Clamp Diode Voltage	V <sub>DD</sub> =Max., I <sub>IN</sub> =-18mA		-0.7+V <sub>SS</sub>	-1.2+V <sub>SS</sub>	
I <sub>IH</sub>	Input HIGH Current	V <sub>DD</sub> =Max., V <sub>IN</sub> =V <sub>DD</sub>			±5	μA
I <sub>IL</sub>	Input LOW Current	V <sub>DD</sub> =Max., V <sub>IN</sub> =V <sub>SS</sub>			±5	

#### Notes:

- For Max. or Min. conditions, use appropriate value specified under Electrical Characteristics for the applicable device type.
- Typical values are at T<sub>A</sub> = 25°C ambient and maximum loading.
- V<sub>IH</sub> & V<sub>IL</sub> are for SEL input only.

### Power Supply Characteristics

Parameters	Description	Test Conditions <sup>(1)</sup>	Min.	Typ. <sup>(2)</sup>	Max.	Units
I <sub>CC</sub>	Quiescent Power Supply Current	V <sub>DD</sub> = Max., V <sub>IN</sub> = V <sub>DD</sub> or V <sub>SS</sub>		300	400	μA

**Notes:**

1. For Max. or Min. conditions, use appropriate value specified under Electrical Characteristics for the applicable device type.
2. Typical values are at T<sub>A</sub> = 25°C ambient and maximum loading.

### Switching Characteristics (T<sub>A</sub> = -40° to +85°C, V<sub>SS</sub>=0V, V<sub>DD</sub>=1.8V ±10%)

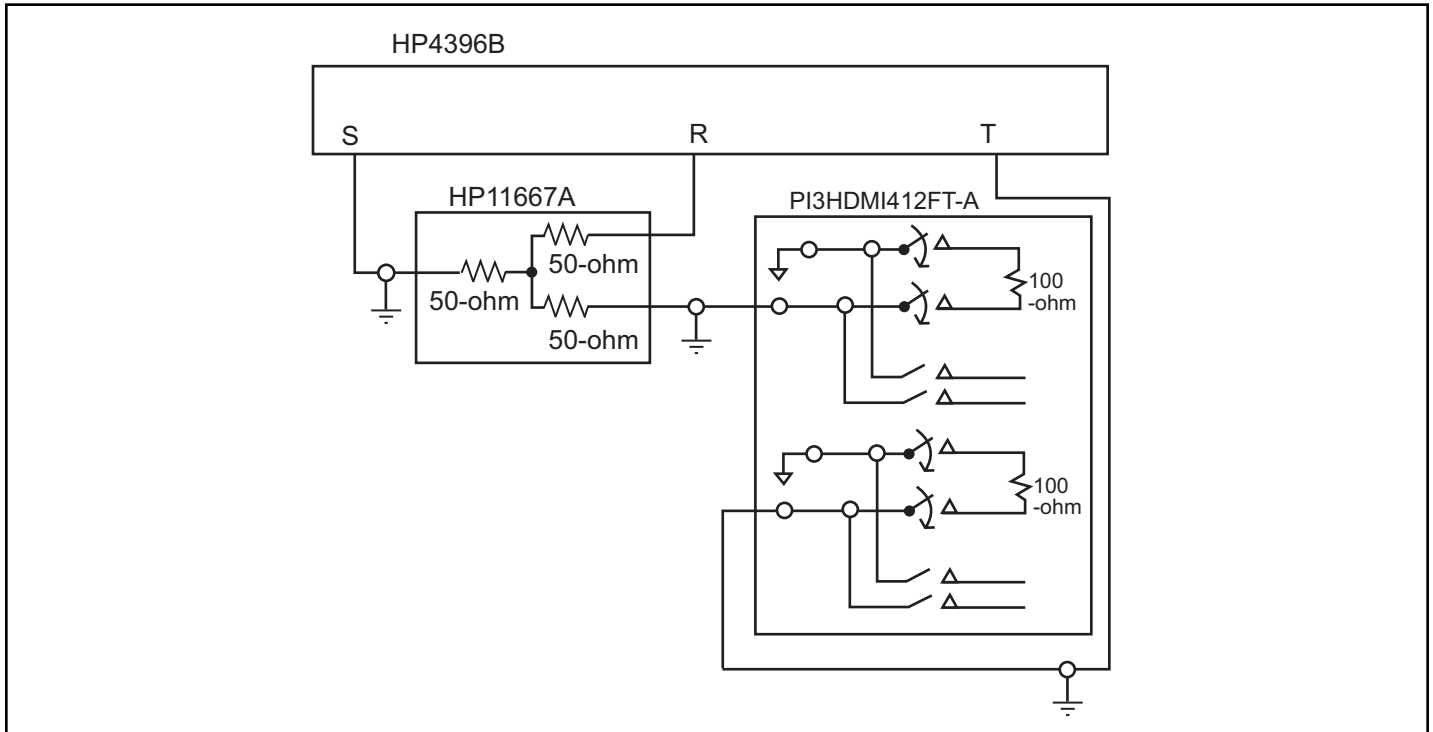
Parameter	Description	Min.	Max.	Units
t <sub>PZH</sub> , t <sub>PZL</sub>	Line Enable Time - SEL to N <sup>A</sup> , N <sup>B(1)</sup>	0.5	8.0	ns
t <sub>PHZ</sub> , t <sub>PLZ</sub>	Line Disable Time - SEL to N <sup>A</sup> , N <sup>B(1)</sup>	0.5	4.0	

**Notes:**

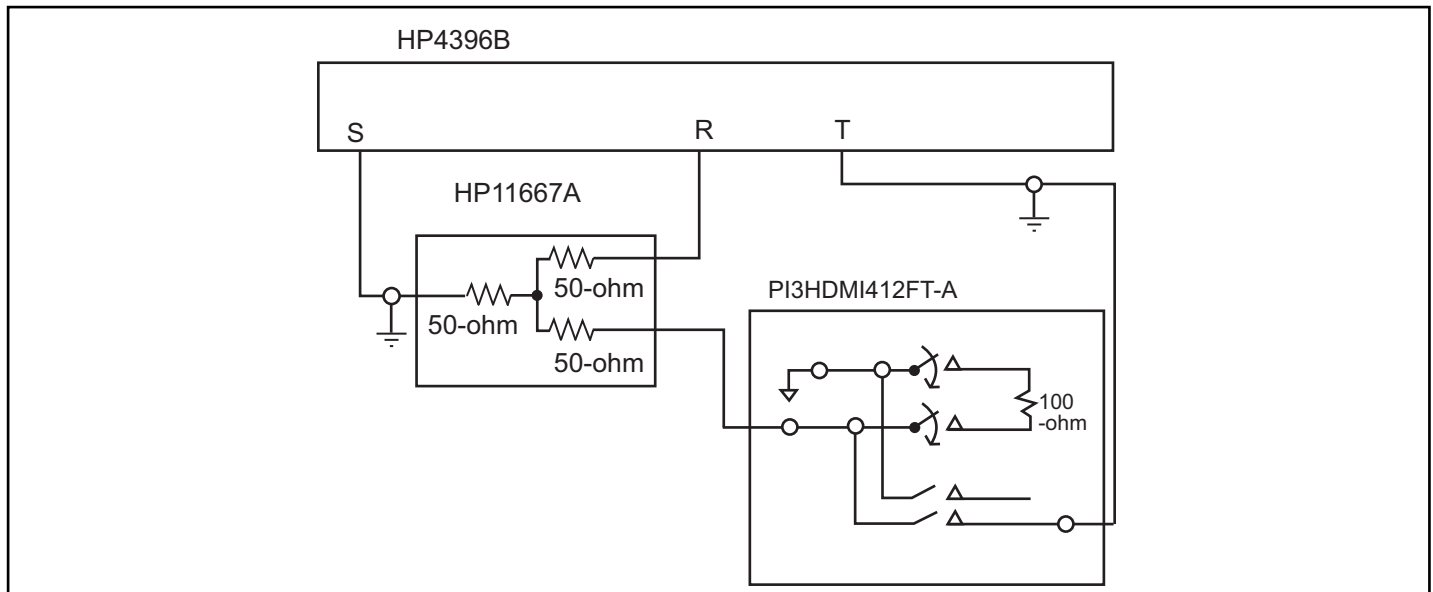
1. For measurement setup, please see “Test Circuit For Electrical Characteristic” on page 8, and “Switching waveforms” on page 9

### Dynamic Electrical Characteristics Over the Operating Range (T<sub>A</sub> = -40° to +85°C)

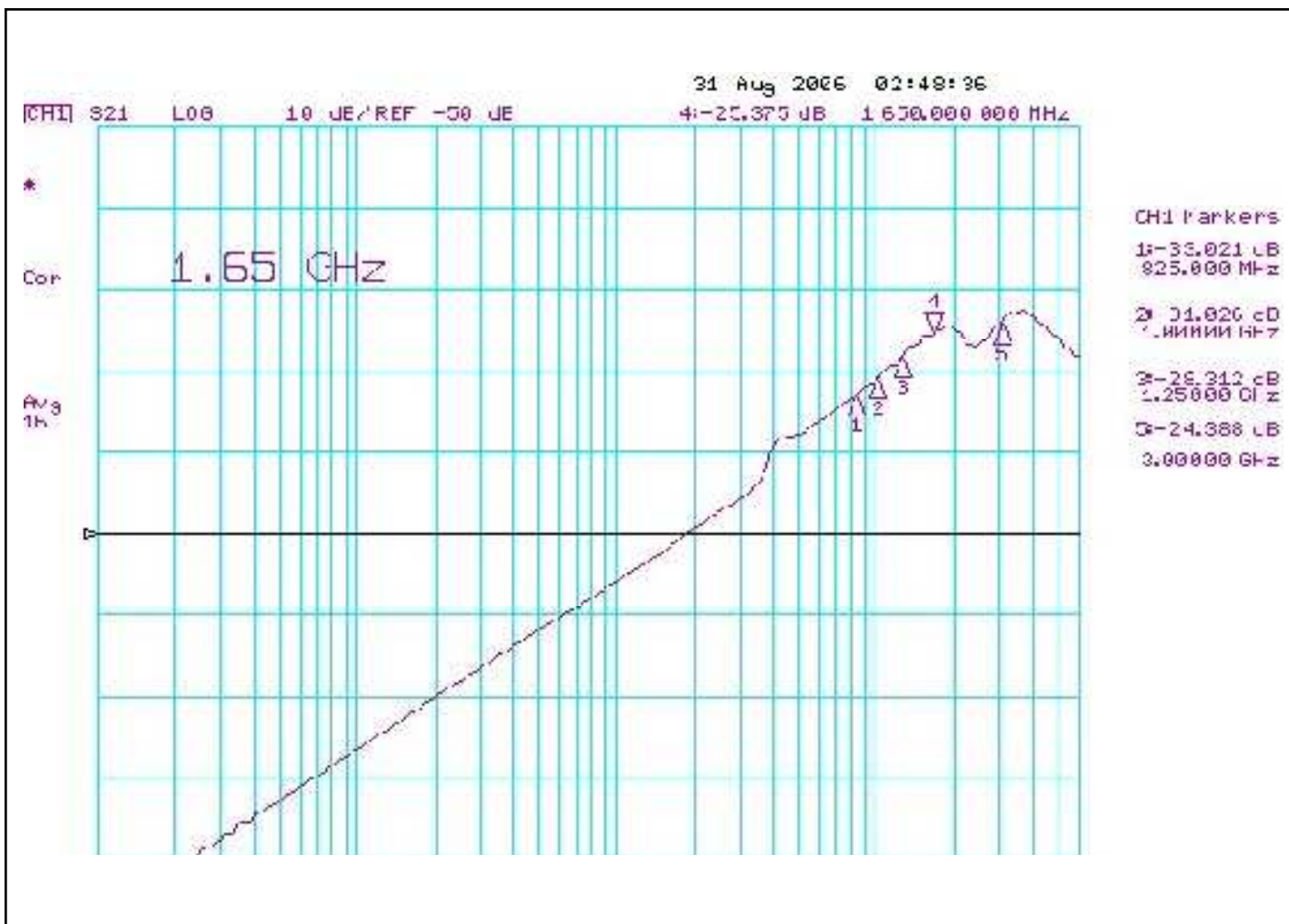
Parameter	Description	Test Conditions	Min.	Typ.	Max.	Units
X <sub>TALK</sub>	Crosstalk	See Fig. 1 for Measurement Setup, @ 2.0 Gbps		-31		dB
O <sub>IRR</sub>	OFF Isolation	See Fig. 2 for Measurement Setup, @ 2.0 Gbps		-40		
BW	-3dB BW			2.7		GHz
Insertion Loss		@ 1.65 Gbps		-0.87		dB
		@ 2.0 Gbps		-0.95		
		@ 2.5 Gbps		-1.18		
		@ 3.3 Gbps		-1.85		



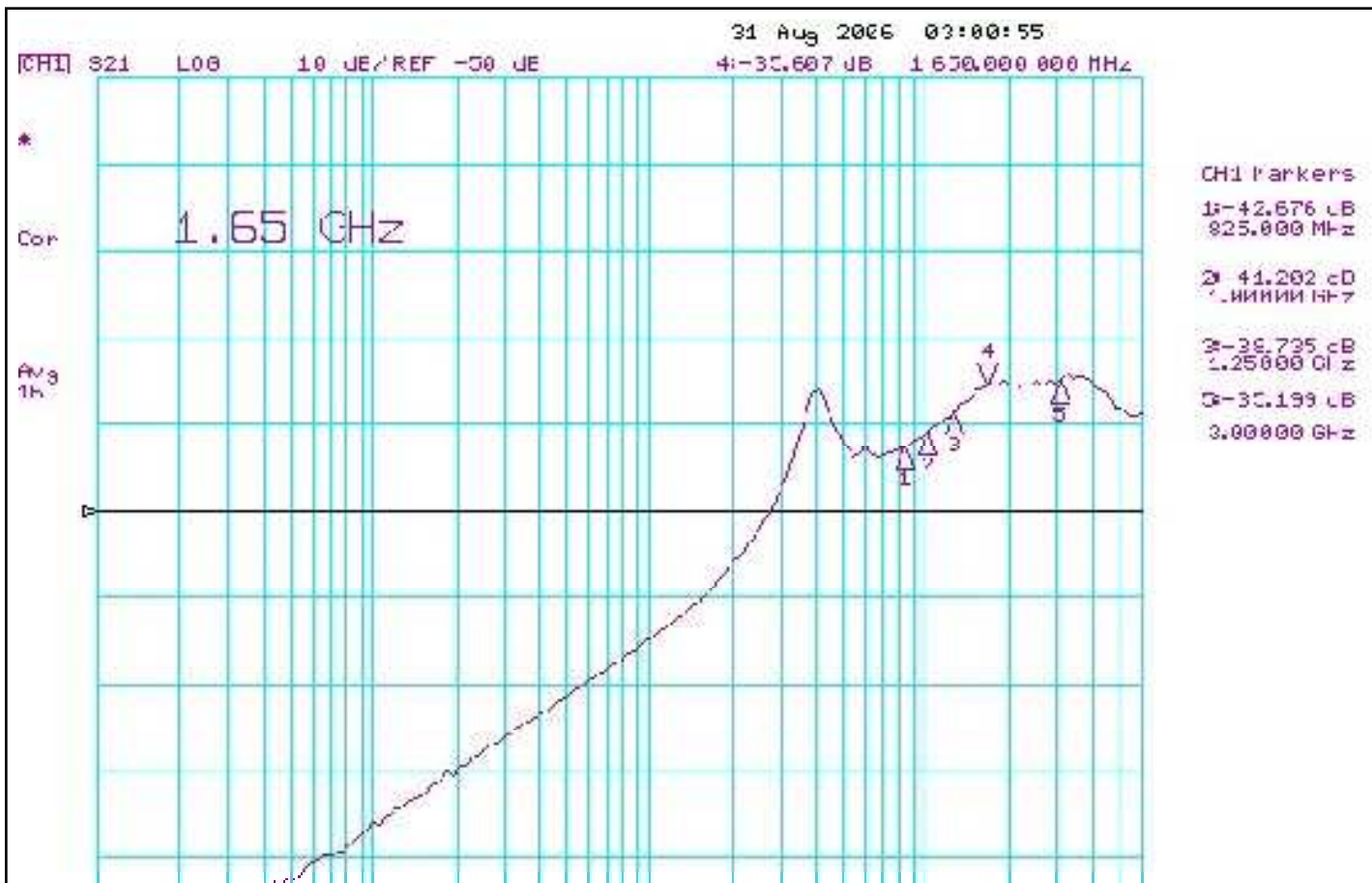
**Fig 1. Crosstalk Setup**



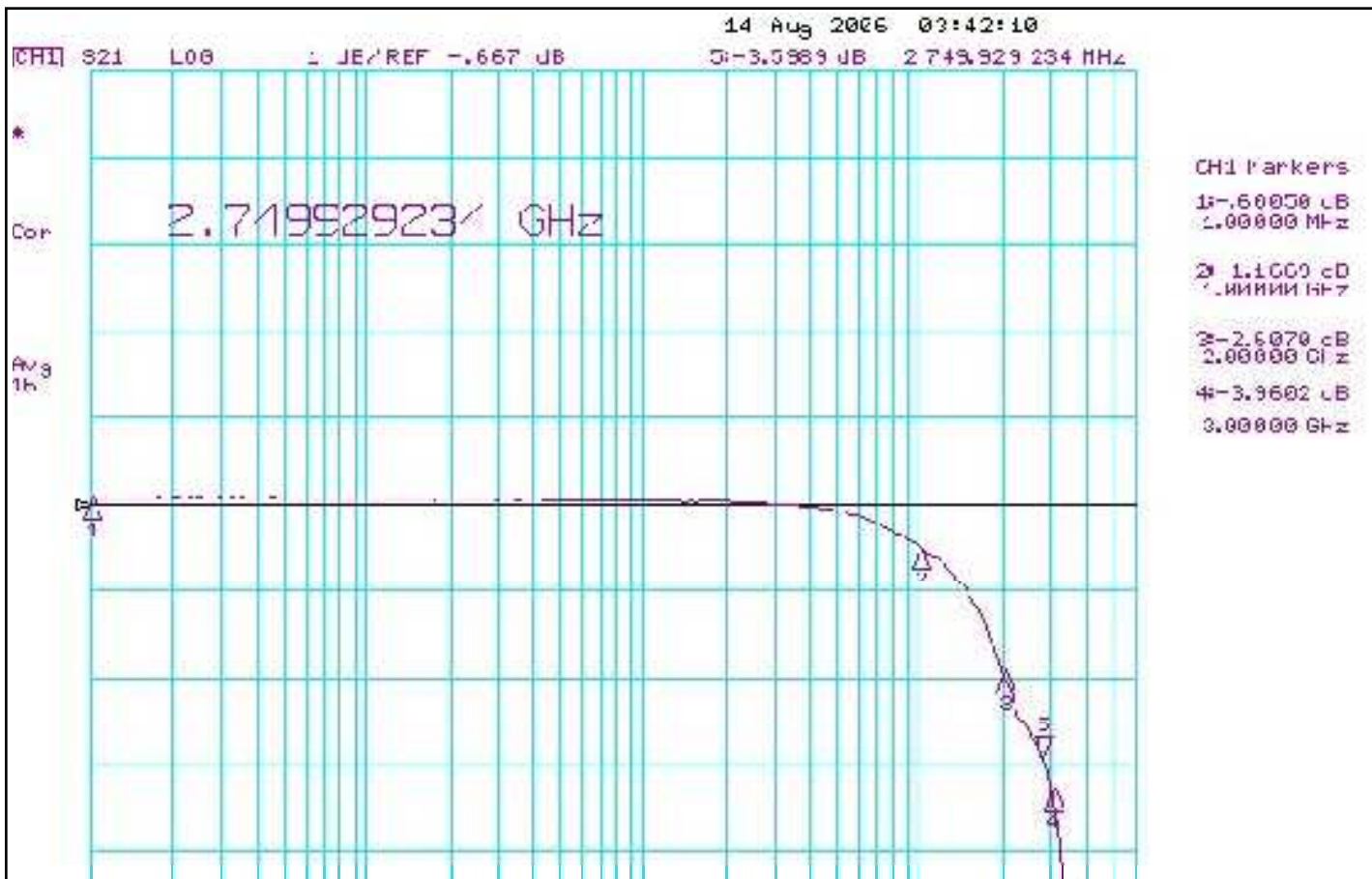
**Fig 2. Off-isolation setup**



**Fig 3. Crosstalk**

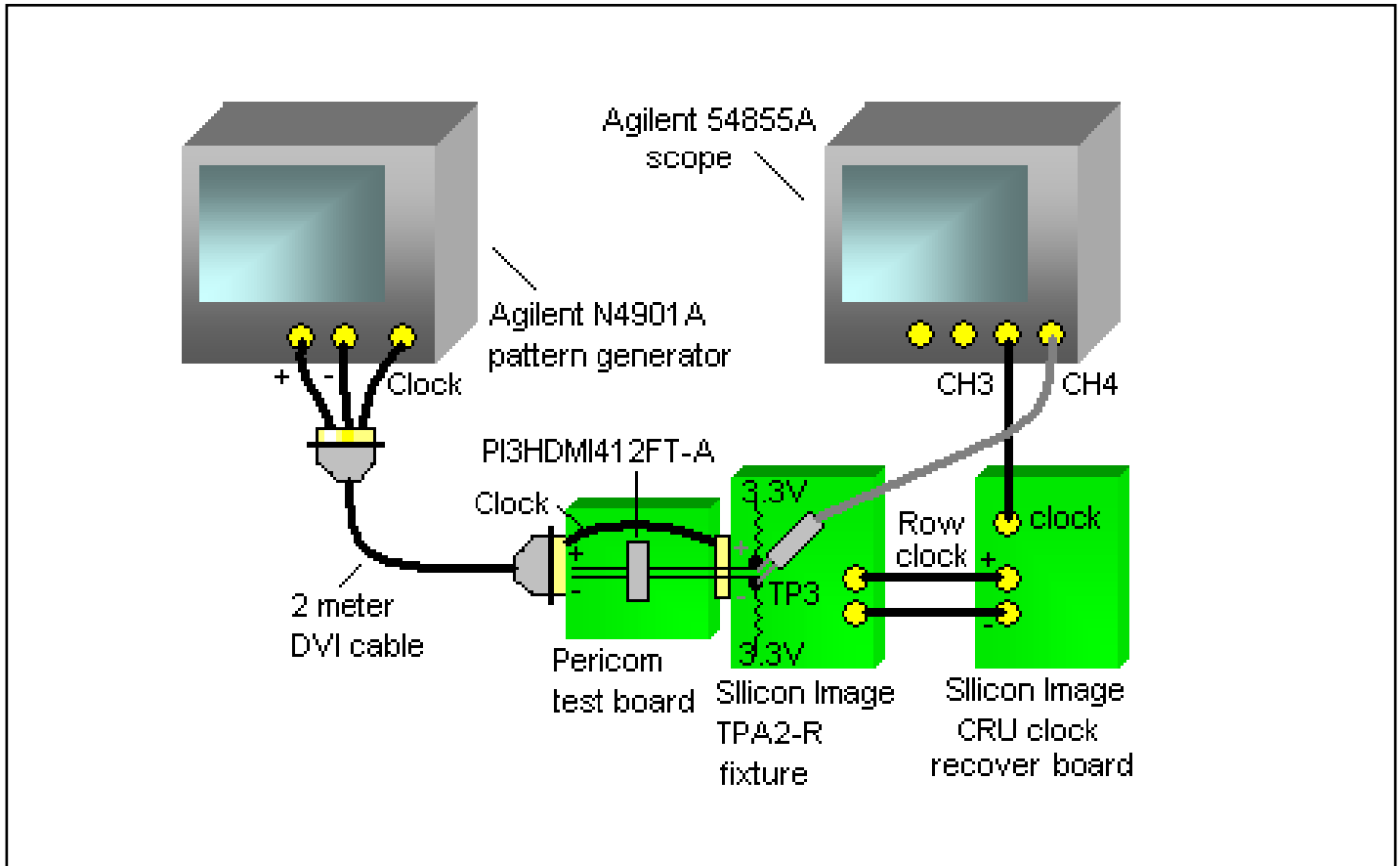


**Fig 4. Off Isolation**



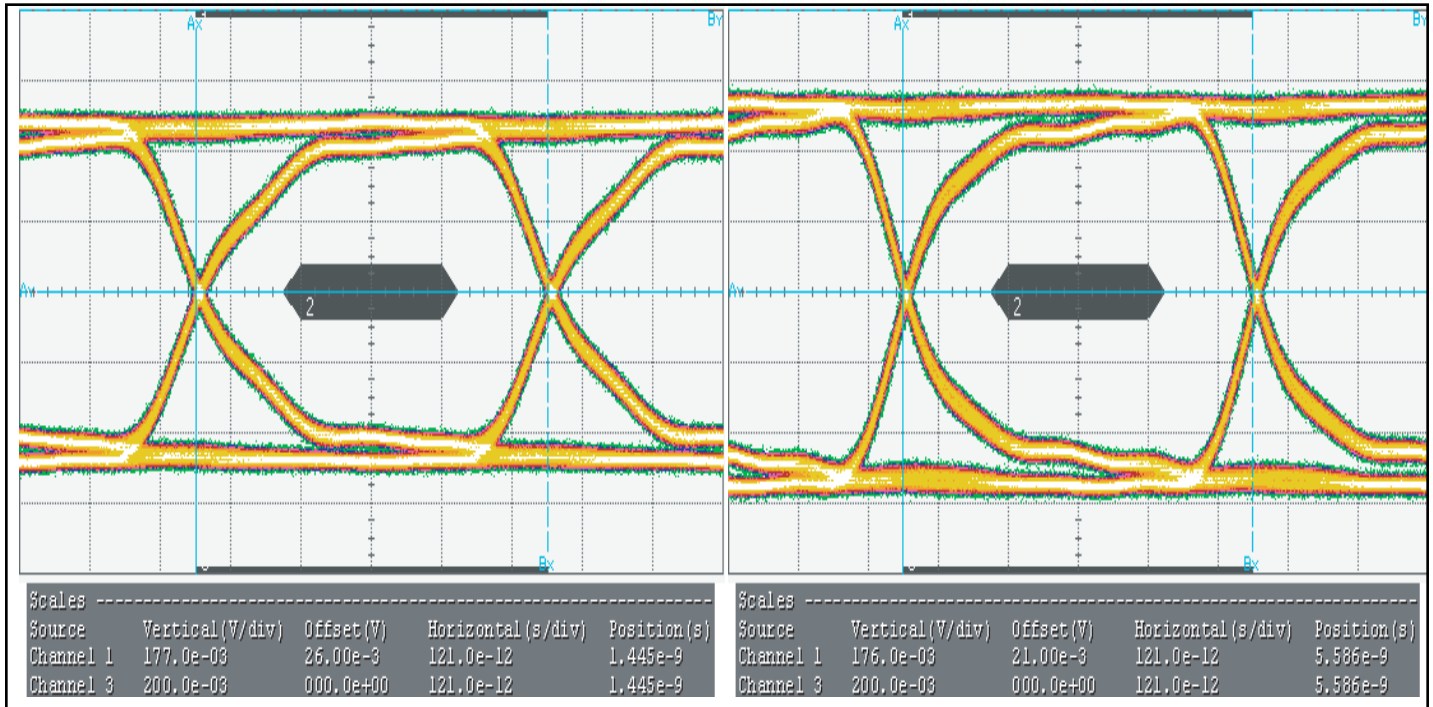
**Fig 5. Insertion Loss**

**Application Measurements**



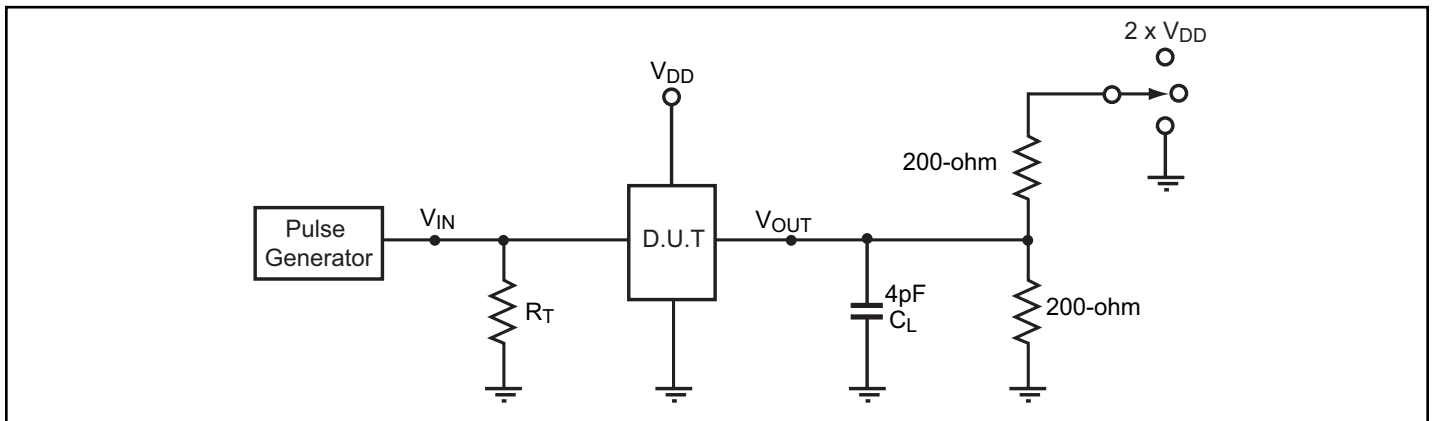
**Fig 6. TMDS TP3 Rx eye compliance Test Setup**





**Fig 7. TP3 (Rx) with 2-meter cable eye measurements**  
(Right eye is with no switch. Left eye is with switch.)

### Test Circuit for Electrical Characteristics



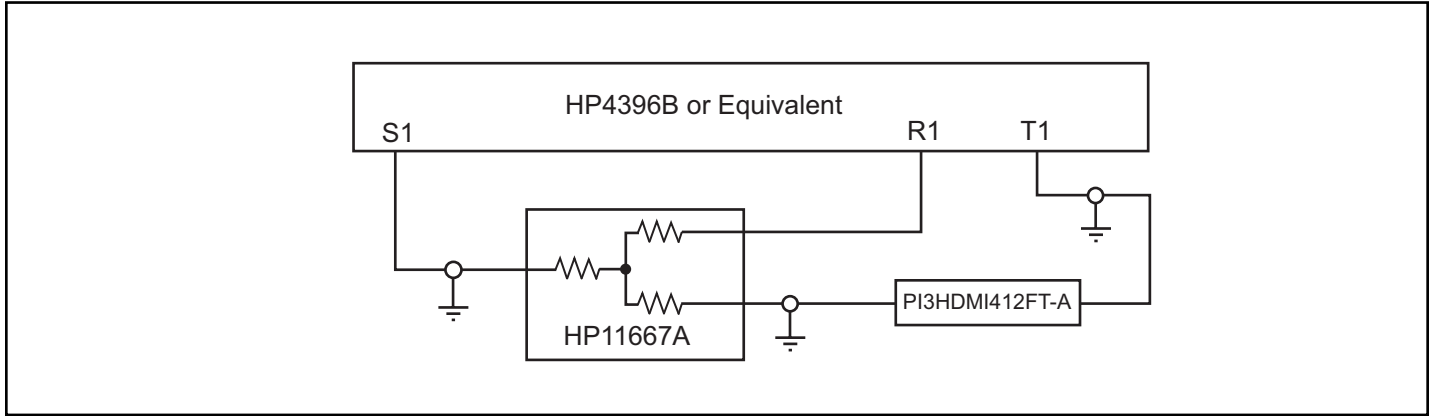
**Notes:**

1.  $C_L$  = Load capacitance: includes jig and probe capacitance.
2.  $R_T$  = Termination resistance: should be equal to  $Z_{OUT}$  of the Pulse Generator
3. Waveform 1 is for an output with internal conditions such that the output is low except when disabled by the output control.  
Waveform 2 is for an output with internal conditions such that the output is high except when disabled by the output control.
4. All input impulses are supplied by generators having the following characteristics:  $PRR \leq \text{MHz}$ ,  $Z_O = 50\Omega$ ,  $t_R \leq 2.5\text{ns}$ ,  $t_F \leq 2.5\text{ns}$ .
5. The outputs are measured one at a time with one transition per measurement.

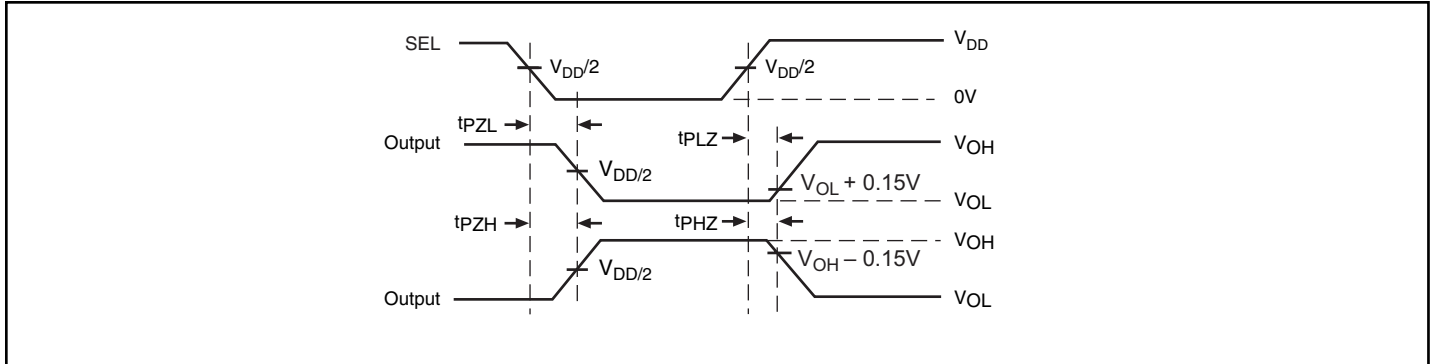
### Switch Positions

Test	Switch
$t_{PLZ}$ , $t_{PZL}$	$2 \times (V_{DD} - V_{SS})$
$t_{PHZ}$ , $t_{PZH}$	$V_{SS}$
Prop Delay	Open

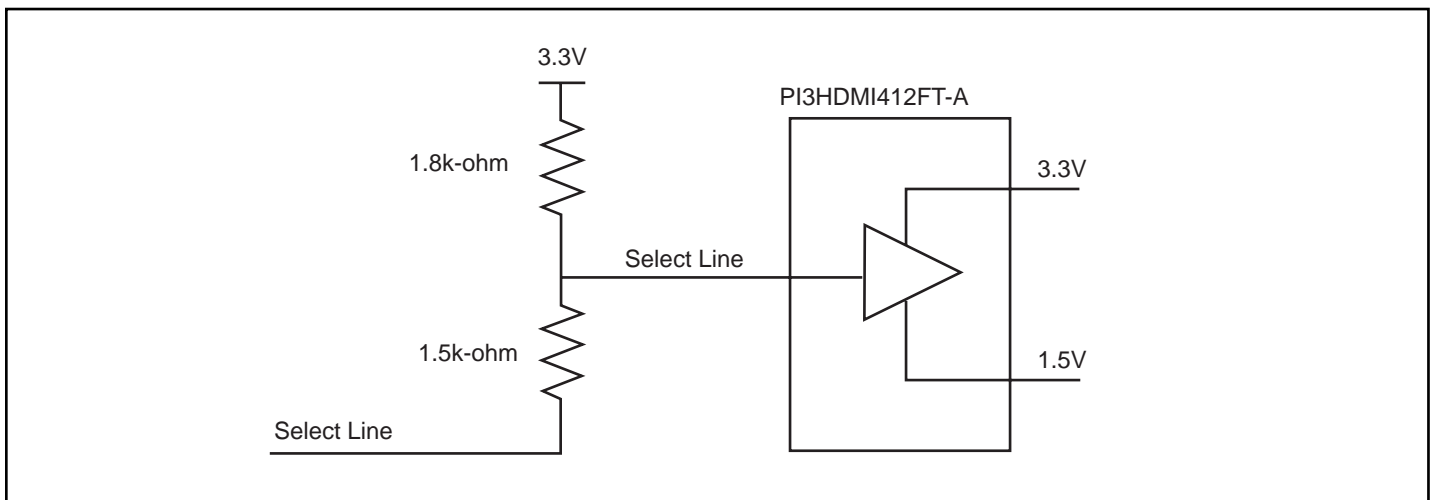
**Test Circuit for Dynamic Electrical Characteristics**



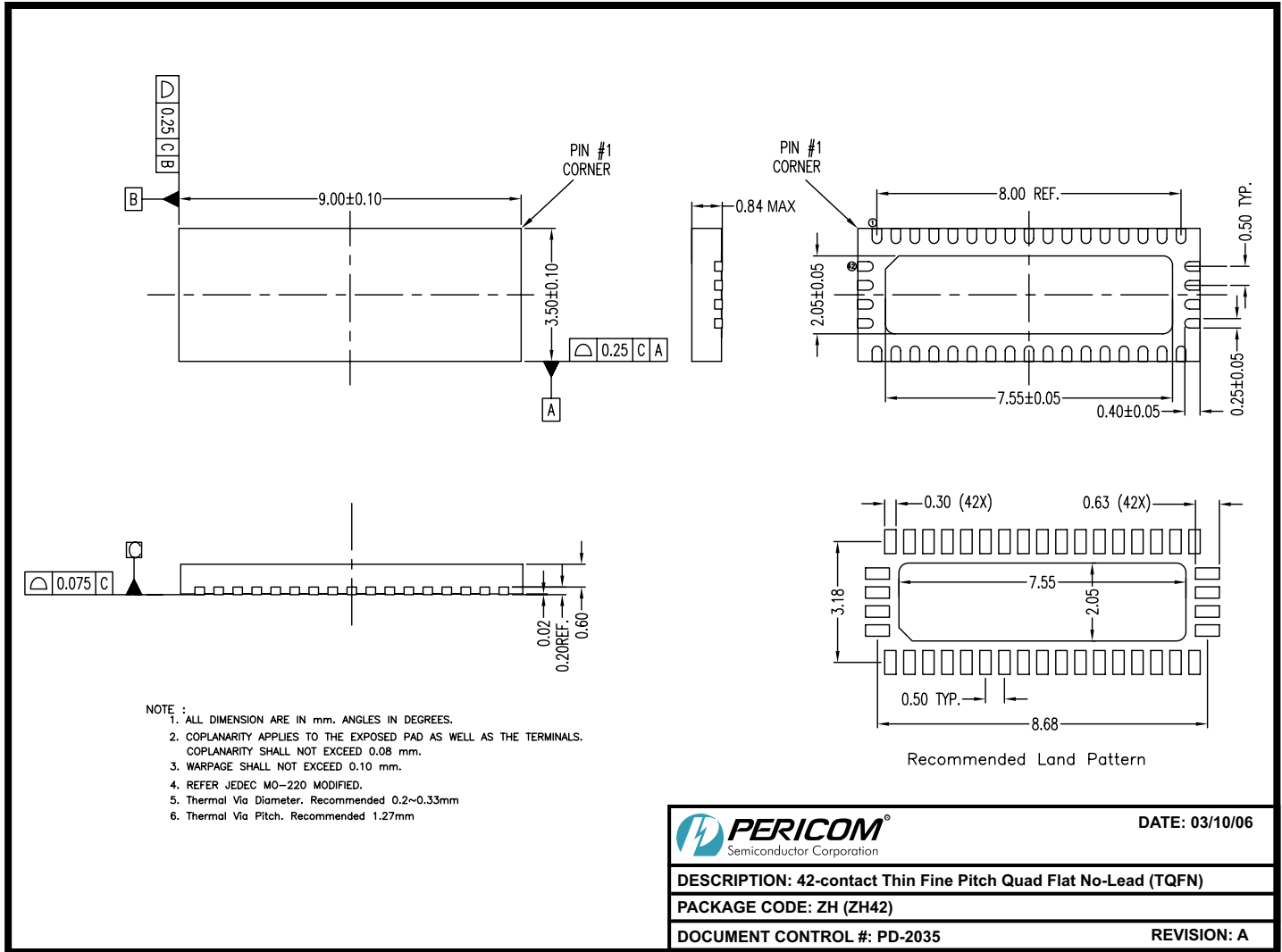
**Switching Waveforms**

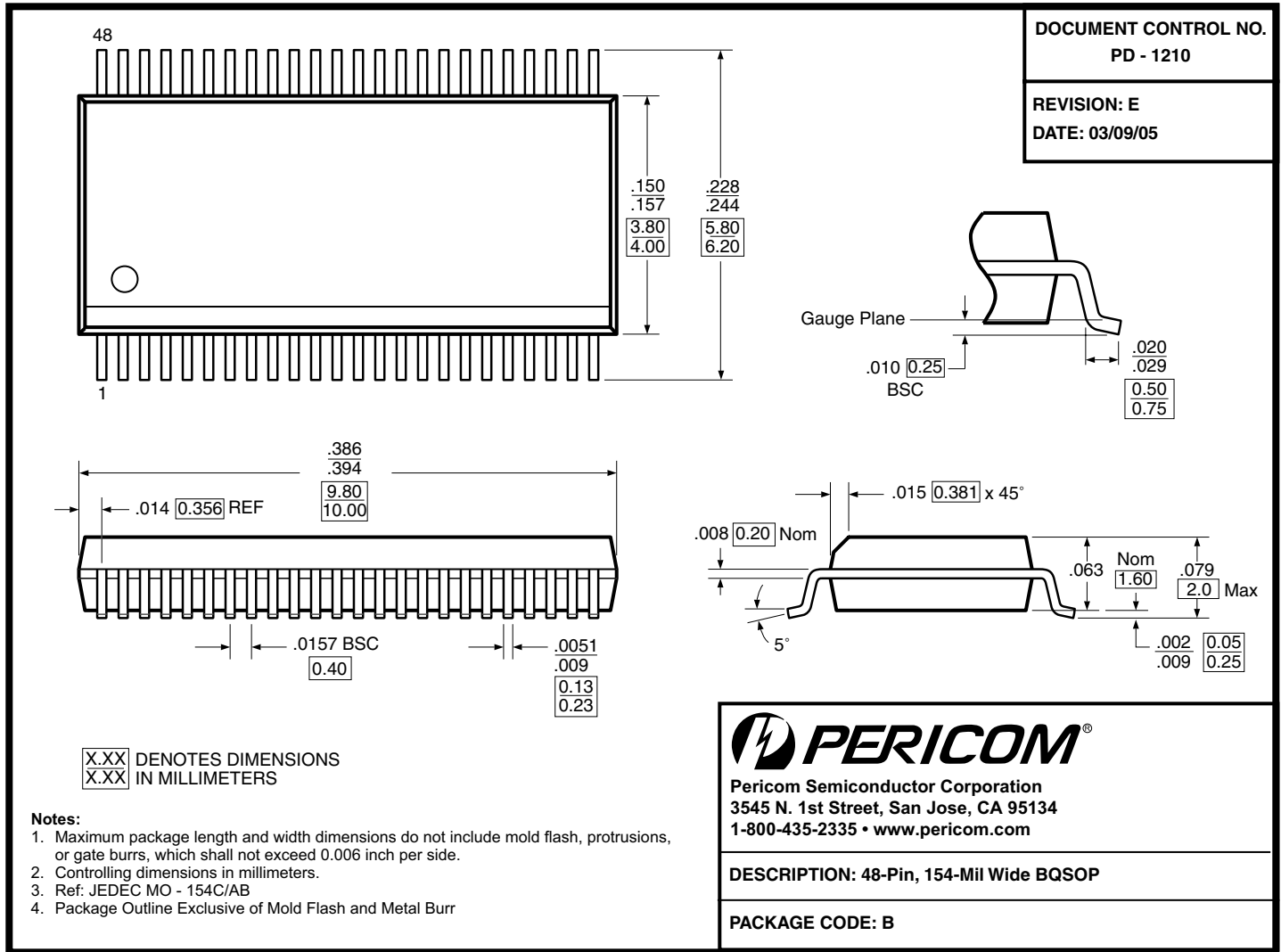


**Voltage Waveforms Enable and Disable Times**



**Example of a circuit that also needs to be connected to the select lines of the PI3HDMI412FT-A**





### Ordering Information

Ordering Code	Package Code	Package Description
PI3HDMI412FT-AZHE	ZH	Pb-free & Green, 42-pin TQFN
PI3HDMI412FT-ABE	B	Pb-free & Green, 48-pin BQSOP

**Notes:**

- Thermal characteristics can be found on the company web site at [www.pericom.com/packaging/](http://www.pericom.com/packaging/)
- E = Pb-free and Green
- Adding X suffix = Tape/Reel