

3.3V Quad, 2:1 Mux/DeMux Fast Ethernet LAN Switch w/ Single Enable

Features

- R_{ON} is 4Ω typical
- Low crosstalk: -27dB @ 250 MHz
- Near-Zero propagation delay: 250ps
- Switching speed: 9ns
- Channel On capacitance: 9pF (typical)
- V_{CC} Operating Range: +3.0V to +3.6V
- $>2\text{kV}$ ESD protection (human body model)
- >350 MHz bandwidth (or data frequency)
- Switching on Data I/O Ports (0 to 5V)
- I_{OFF} supports Partial-Power-Down mode operation
- Data and Control Inputs have Undershoot Clamp Diodes
- Packaging (Pb-free & Green available)
 - 16-pin 150-mil wide plastic QSOP (Q)
 - 16-pin 173-mil wide plastic TSSOP (L)

Applications

- Dual Physical Layer Device sharing to one interface connector
- Routes signals for 10/100 Mbit Ethernet

Description

The PI3L110 is a 8- to 4-bit multiplexer/demultiplexer LAN Switch with Hi-Z outputs. Industry leading advantages include a propagation delay of less than 250ps, resulting from its low channel resistance and I/O capacitance. The device multiplexes differential outputs from a Fast Ethernet transceiver (PHY) device to one of two corresponding outputs. The switch is bidirectional and offers little or no attenuation of the high-speed signals at the outputs. It is designed for low bit-to-bit skew, high channel-to-channel noise isolation and is compatible with various standards, such as 10/100 Base-T (Ethernet).

Generally, this part can be used to replace mechanical relays in low-voltage LAN applications that interface a physical layer over CAT 5 or CAT 6 unshielded twisted pair cable through an isolation transformer.

The PI3L110 is fully specified for partial-power-down applications using I_{OFF} . The I_{OFF} feature ensures that damaging current will not backflow throughout the device when it is powered down. The device has isolation during Power Off.

Block Diagram

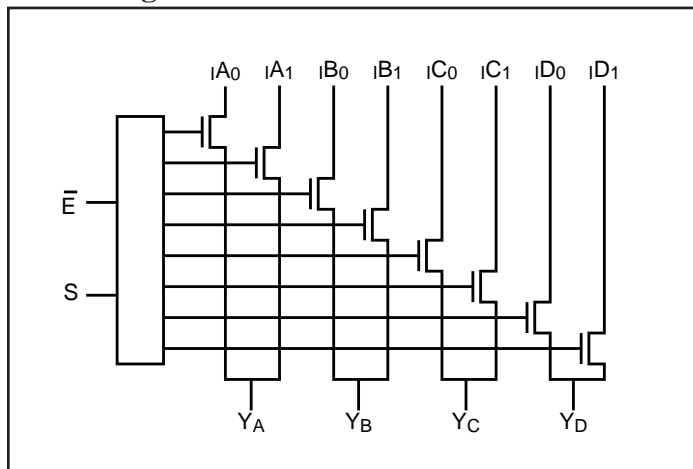

Pin Configuration

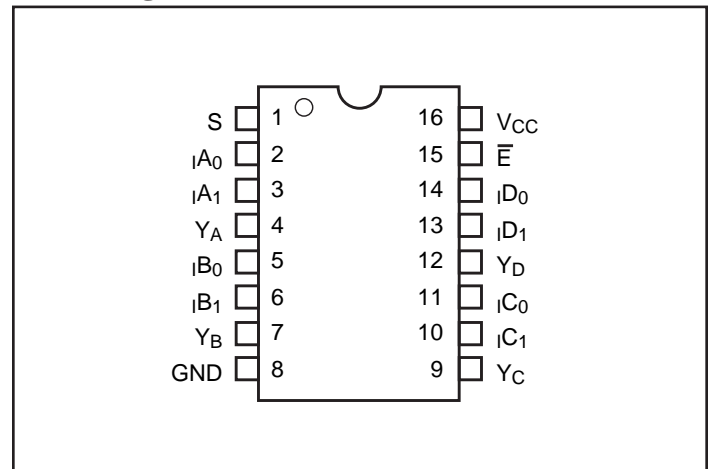

Truth Table⁽¹⁾

\bar{E}	S	YA	YB	YC	YD	Function
H	X	Hi-Z	Hi-Z	Hi-Z	Hi-Z	Disable
L	L	I _{A0}	I _{B0}	I _{C0}	I _{D0}	S = 0
L	H	I _{A1}	I _{B1}	I _{C1}	I _{D1}	S = 1

Note:

- H = High Voltage Level
 L = Low Voltage Level
 X = Don't Care

Pin Description

Pin Name	Description
I _{AN} -I _{DN}	Data Inputs
S	Select Inputs
\bar{E}	Enable
YA-YD	Data Outputs
GND	Ground
V _{CC}	Power

Maximum Ratings

(Above which useful life may be impaired. For user guidelines, not tested.)

Storage Temperature	-65°C to +150°C
Supply Voltage to Ground Potential	-0.5V to +4.0V
DC Input Voltage	-0.5V to +5.5V
DC Output Current.....	120mA
Power Dissipation.....	0.5W

Note: Stresses greater than those listed under MAXIMUM RATINGS may cause permanent damage to the device. This is a stress rating only and functional operation of the device at these or any other conditions above those indicated in the operational sections of this specification is not implied. Exposure to absolute maximum rating conditions for extended periods may affect reliability.

DC Electrical Characteristics for 10/100 Base-T Ethernet Switching over Operating Range

(T_A = -40°C to +85°C, V_{CC} = 3.3V ±10%)

Parameter	Description	Test Conditions ⁽¹⁾	Min.	Typ. ⁽²⁾	Max.	Units
V _{IH}	Input HIGH Voltage	Guaranteed HIGH level	2.0			V
V _{IL}	Input LOW Voltage	Guaranteed LOW level	-0.5		0.8	
V _{IK}	Clamp Diode Voltage	V _{CC} = Max., I _{IN} = -18mA		-0.7	-1.2	
I _{IH}	Input HIGH Current	V _{CC} = Max., V _{IN} = V _{CC}			±5	μA
I _{IL}	Input LOW Current	V _{CC} = Max., V _{IN} = GND			±5	μA
I _{OFF}	Current while I/O disabled	V _{CC} = 0, V _O = 0 to 5V			1	μA
R _{ON}	Switch On-Resistance ⁽³⁾	V _{CC} = Min., 1.25V ≤ V _{IN} ≤ V _{CC} , I _{IN} = -10mA to -30mA		4.0	8.0	Ω
R _{FLAT(ON)}	On-Resistance Flatness ⁽⁴⁾	V _{CC} = Min., V _{IN} @ 1.25V and V _{CC} , I _{IN} = -10mA to -30mA		1		
ΔR _{ON}	On-Resistance match from center ports to any other port ⁽⁴⁾	V _{CC} = Min., 1.25V ≤ V _{IN} ≤ V _{CC} , I _{IN} = -10mA to -30mA		0.9	2.0	

Notes:

- For max. or min. conditions, use appropriate value specified under Electrical Characteristics for the applicable device type.
- Typical values are at V_{CC} = 3.3V, T_A = 25°C ambient and maximum loading.
- Measured by the voltage drop between I_N and Y_N pins at indicated current through the switch. On-Resistance is determined by the lower of the voltages on the two (I_N & Y_N) pins.
- This parameter is determined by device characterization but is not production tested.

Capacitance ($T_A = 25^\circ\text{C}$, $f = 1\text{ MHz}$)

Parameters ⁽¹⁾	Description	Test Conditions	Typ.	Max.	Units
C_{IN}	Input Capacitance	$V_{IN} = 0V$	2	3	pF
$C_{OFF(IN)}$	Port I_N Capacitance, Switch OFF		4	6	
C_{ON}	Y_N/I_N Capacitance, Switch ON		9	10	

Notes:

- This parameter is determined by device characterization but is not production tested.

Power Supply Characteristics

Parameters	Description	Test Conditions ⁽¹⁾	Min.	Typ. ⁽²⁾	Max.	Units
I_{CC}	Quiescent Power Supply Current	$V_{CC} = \text{Max.}, V_{IN} = \text{GND or } V_{CC}$			800	μA

Notes:

- For max. or min. conditions, use appropriate value specified under Electrical Characteristics for the applicable device type.
- Typical values are at $V_{CC} = 3.3V$, $T_A = 25^\circ\text{C}$ ambient and maximum loading.

Dynamic Electrical Characteristics Over the Operating Range

($T_A = -40^\circ\text{C}$ to $+85^\circ\text{C}$, $V_{CC} = 3.3V \pm 10\%$, $\text{GND} = 0V$)

Parameter	Description	Test Conditions	Min.	Typ.	Max.	Units
X_{TALK}	Crosstalk	$R_L = 50\Omega$, $f = 250\text{ MHz}$		-40		dB
O_{IRR}	OFF Isolation			-30		
BW	Bandwidth -3dB	$R_L = 50\Omega$		350		MHz

Characteristics

Parameter	Description	Test Conditions	Min.	Typ. ⁽¹⁾	Max.	Units
t_{PD}	Propagation Delay ^(2,3)			0.25		ns
t_{PZH}, t_{PZL}	Line Enable Time - S or \bar{E} to Y_N, I_N		0.5		15	
t_{PHZ}, t_{PLZ}	Line Disable Time - S to \bar{E} to Y_N, I_N		0.5		9	
$t_{SK(p)}$	Skew between opposite transitions of the same output ($t_{PHL} - t_{PLH}$) ⁽²⁾			0.1	0.2	

Notes:

- For max. or min. conditions, use appropriate value specified under Electrical Characteristics for the applicable device type.
- Guaranteed by design.
- The bus switch contributes no propagational delay other than the RC delay of the On-Resistance of the switch and the load capacitance. The time constant for the switch alone is of the order of 0.25ns for 10pF load. Since this time constant is much smaller than the rise/fall times of typical driving signals, it adds very little propagational delay to the system. Propagational delay of the bus switch when used in a system is determined by the driving circuit on the driving side of the switch and its interactions with the load on the driven side.

Test Circuit for Electrical Characteristics

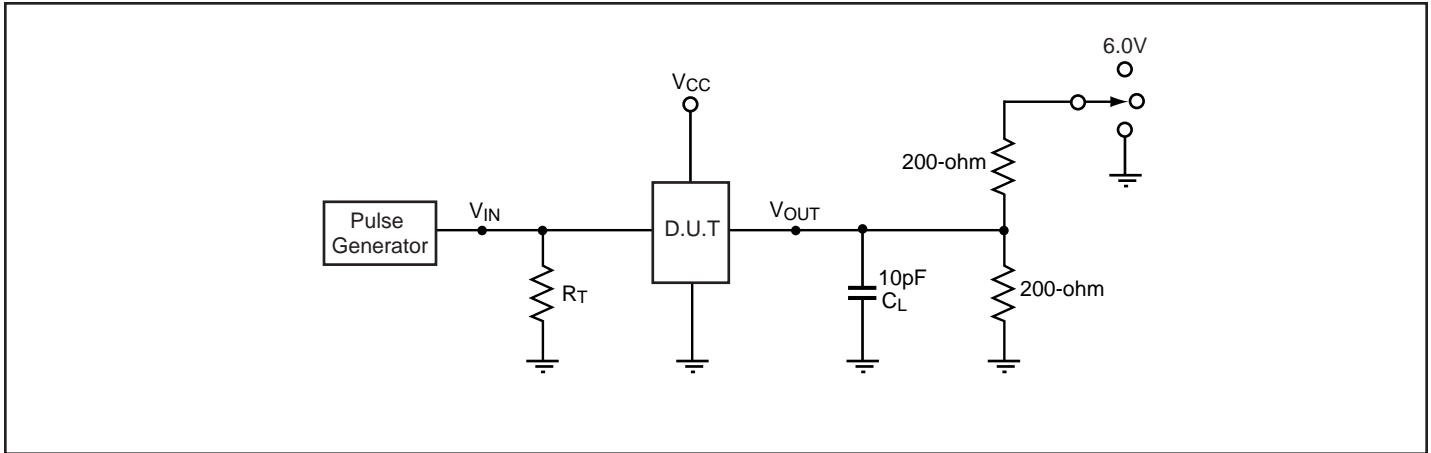

Notes:

- C_L = Load capacitance: includes jig and probe capacitance.
- R_T = Termination resistance: should be equal to Z_{OUT} of the Pulse Generator
- Waveform 1 is for an output with internal conditions such that the output is low except when disabled by the output control.
- Waveform 2 is for an output with internal conditions such that the output is high except when disabled by the output control.
- All input impulses are supplied by generators having the following characteristics: $PRR \leq 10$ MHz, $Z_O = 50\Omega$, $t_R \leq 2.5$ ns, $t_F \leq 2.5$ ns.
- The outputs are measured one at a time with one transition per measurement.

Switch Positions

Test	Switch
t_{PLZ} , t_{PZL}	6.0V
t_{PHZ} , t_{PZH}	GND
Prop Delay	Open

Test Circuit for Dynamic Electrical Characteristics

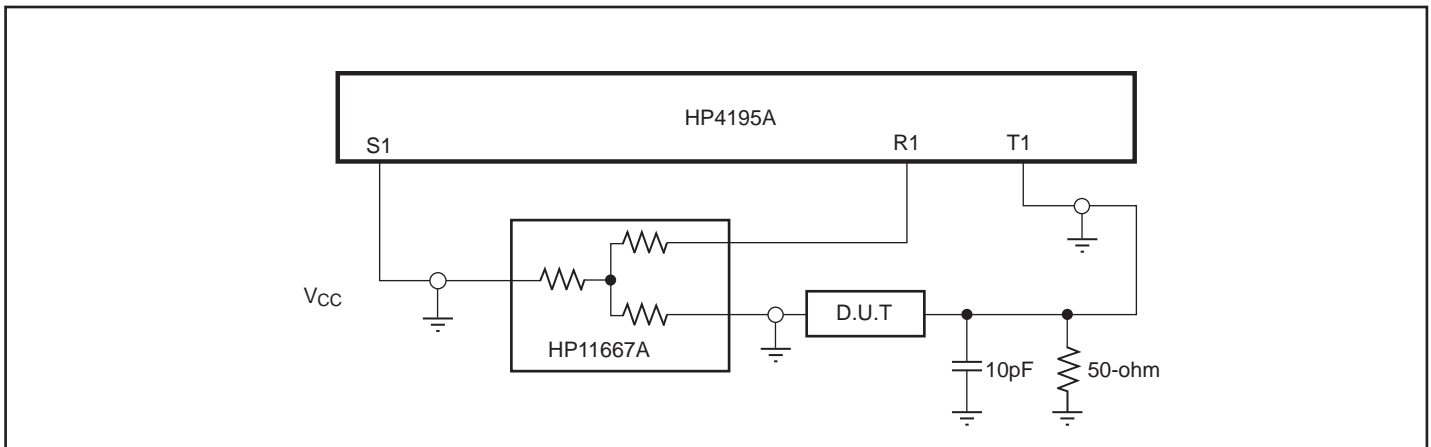

Switching Waveforms

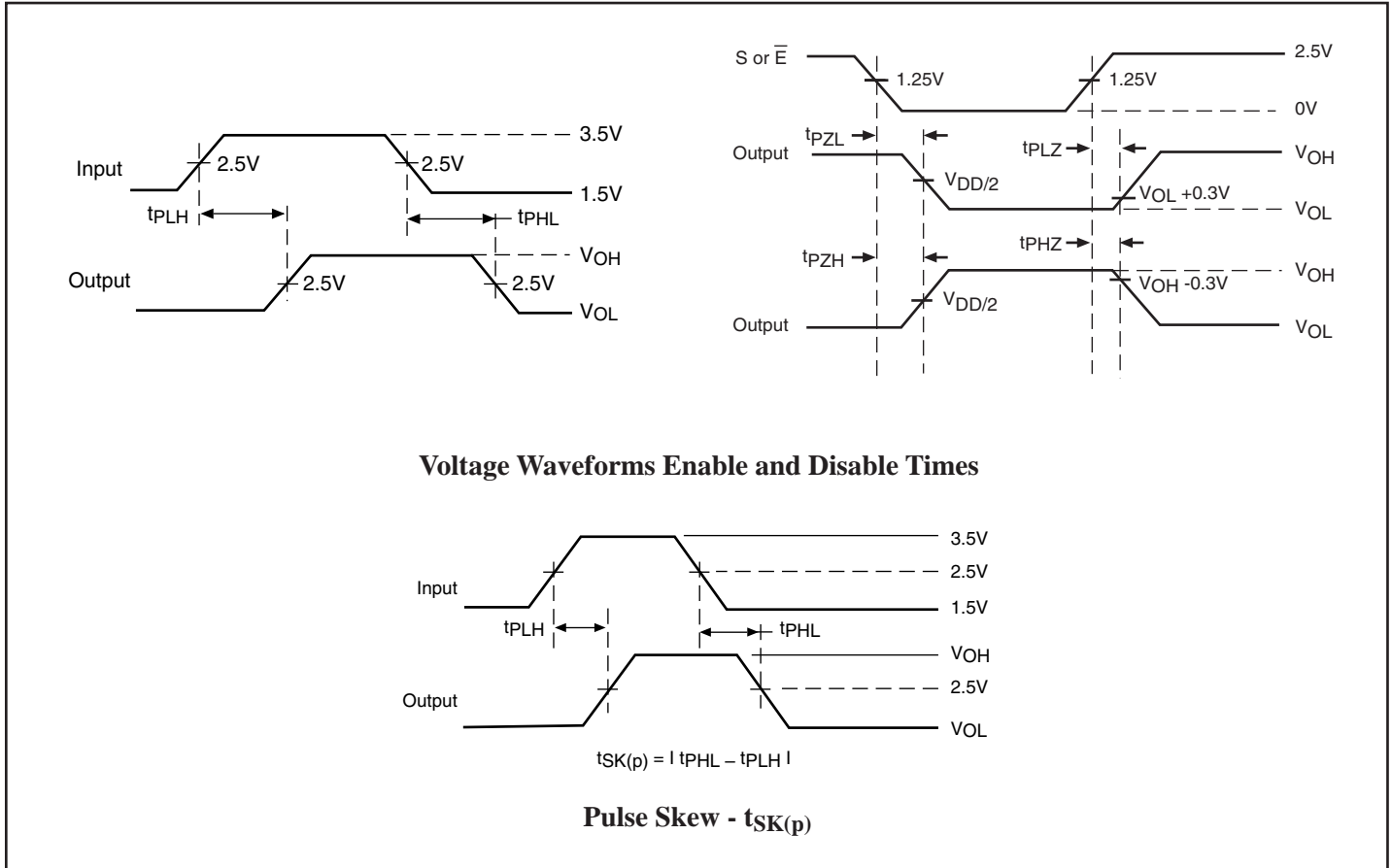

Applications Information

Logic Inputs

The logic control inputs can be driven up to +3.6V regardless of the supply voltage. For example, given a +3.3V supply, the output enables or select pins may be driven low to 0V and high to 3.6V. Driving the control inputs Rail-to-Rail[®] minimizes power consumption.

Rail-to-Rail is a registered trademark of Nippon Motorola, Ltd.

Packaging Mechanical: 16-Pin QSOP (Q)

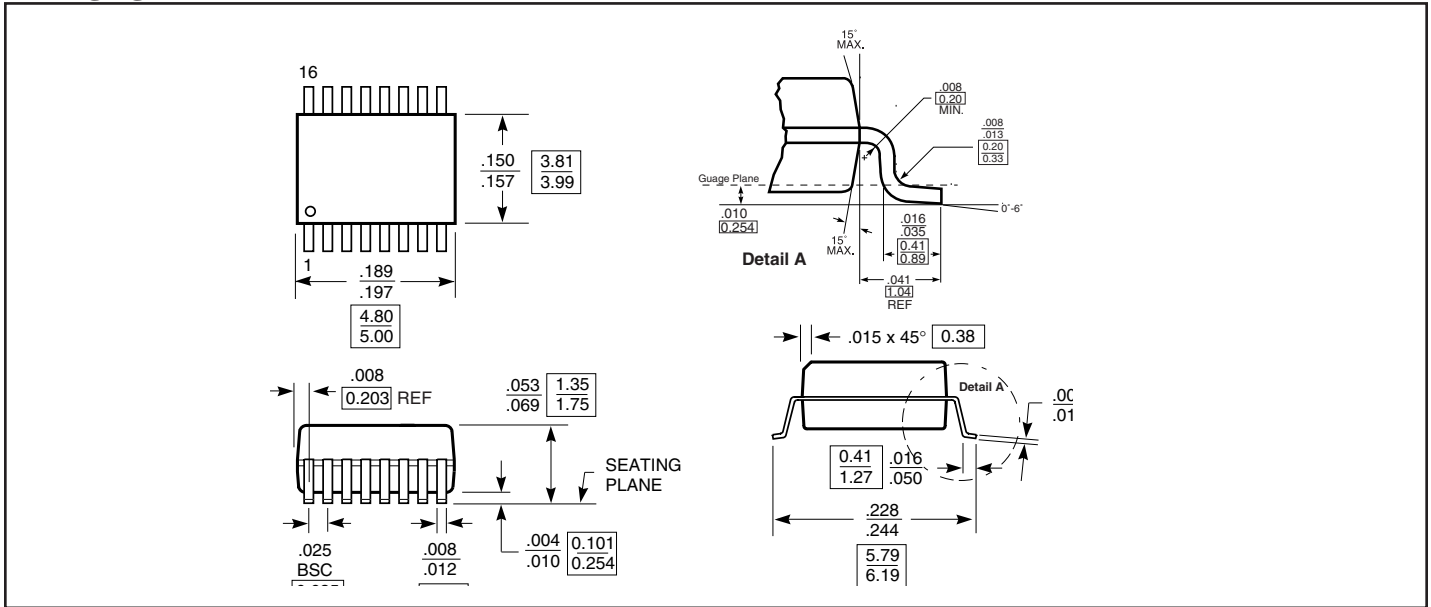

Packaging Mechanical: 16-Pin TSSOP (L)

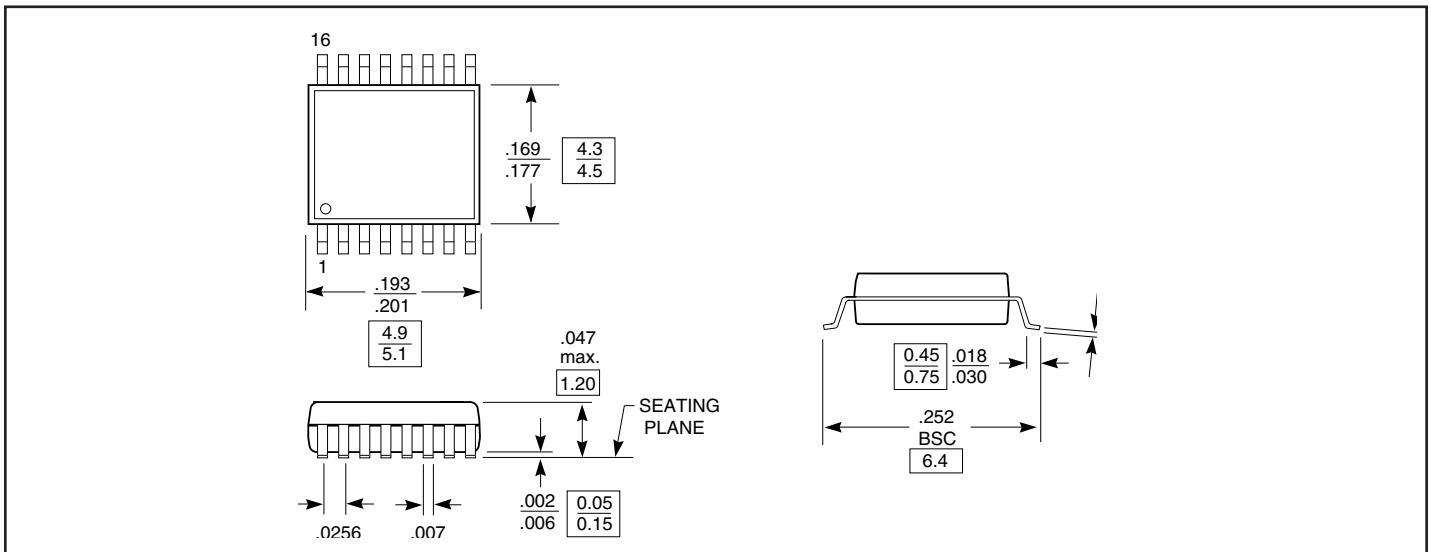

Ordering Information

Ordering Code	Package Code	Package Description
PI3L110Q	Q	16-pin 150-mil wide plastic QSOP
PI3L110QE	Q	Pb-free & Green, 16-pin 150-mil wide plastic QSOP
PI3L110L	L	16-pin 173-mil wide plastic TSSOP
PI3L110LE	L	Pb-free & Green, 16-pin 173-mil wide plastic TSSOP

Notes:

- Thermal characteristics can be found on the company web site at www.pericom.com/packaging/
- E = Pb-free & Green
- Adding an X suffix = Tape/Reel