

## QUAD OPERATIONAL AMPLIFIER

### ■ GENERAL DESCRIPTION

**NJM2745** is quad operational amplifier with low voltage noise  $5\text{nV}/\sqrt{\text{Hz}}$  (@ $f=1\text{kHz}$ ) with high bandwidth and low distortion.

These features may be used in audio signal processing by high-level audio usages such as hi-end car audio, high-quality TV set and others.

In addition, these also suitable for audio mixer, studio-recording equipments, broadcasting equipments, and the usages in various professional sound equipments.

### ■ PACKAGE OUTLINE



NJM2745V

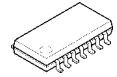

NJM2745M

### ■ FEATURES

- Low Input Noise Voltage             $5\text{nV}/\sqrt{\text{Hz}}$  typ
- Wide Gain Bandwidth Product     $15\text{MHz}$  typ
- Low Distortion                         $0.0005\%$  typ
- Slew Rate                                 $5\text{V}/\mu\text{s}$  typ
- Operating Voltage                     $\pm 2\text{V}$  to  $\pm 9.5\text{V}$
- Package Outline                        NJM2745M : DMP14  
    NJM2745V : SSOP14
  
- Bipolar Technology

### ■ PIN CONFIGURATION

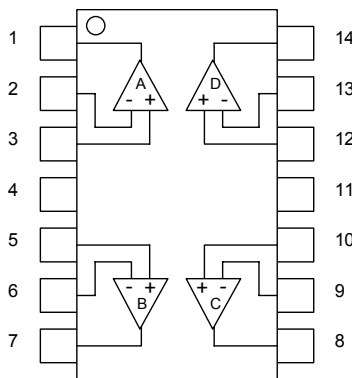

#### PIN ASSIGNMENT

- |             |              |
|-------------|--------------|
| 1. A OUTPUT | 8. C OUTPUT  |
| 2. A -INPUT | 9. C -INPUT  |
| 3. A +INPUT | 10. C +INPUT |
| 4. V+       | 11. V-       |
| 5. B +INPUT | 12. D +INPUT |
| 6. B -INPUT | 13. D -INPUT |
| 7. B OUTPUT | 14. D OUTPUT |

### ■ EQUIVALENT CIRCUIT ( 1/4 Shown )

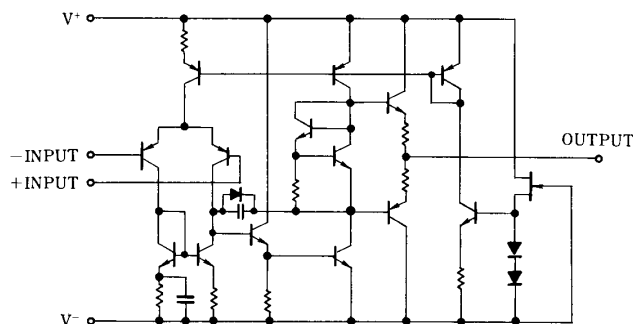

# NJM2745

## ■ ABSOLUTE MAXIMUM RATINGS

(Ta=25°C)

PARAMETER	SYMBOL	RATINGS	UNIT
Supply Voltage	$V^+ / V^-$	±16	V
Common Mode Input Voltage Range	$V_{ICM}$	±13 (Note 1)	V
Differential Input Voltage Range	$V_{ID}$	±26 (Note 1)	V
Power Dissipation	$P_D$	700 [DMP14] (Note 2) 570 [SSOP14] (Note 2)	mW
Load Current	$I_O$	±50 (Note3, Note 4)	mA
Operating Temperature Range	$T_{opr}$	-40~+85	°C
Storage Temperature Range	$T_{stg}$	-40~+150	°C

(Note 1) For supply voltages less than "Absolute Maximum Ratings", the absolute maximum input voltage is equal to the supply voltage.

(Note 2) Mounted on the EIA/JEDEC standard board (76.2 × 114.3 × 1.6mm, two layer FR-4).

(Note 3) It individually takes the absolute value of the sink current and the source current of each output terminal, and it is assumed the sum total. Calculation type:  $I_O = |I_{AOUTPUT}| + |I_{BOUTPUT}| + |I_{COUTPUT}| + |I_{DOUTPUT}|$

(Note 4) Please note the supply current when the load is short-circuited.

## ■ RECOMMENDATION OPERATING CONDITION

(Ta=25°C)

PARAMETER	SYMBOL	RATINGS	MIN.	TYP.	MAX.	UNIT
Supply Voltage	$V^+ / V^-$	(Note 2, Note 5, Note 6) $R_L \geq 10k\Omega$	±2	-	±9.5	V

(Note 5) Do not exceed "Power dissipation:  $P_D$ " in which power dissipation in IC "Symbol: W" is shown by the absolute maximum rating.

Please use it under the system requirements of NJM2745 to always satisfy "Condition:  $P_D \geq W$ ".

The calculation type when using it in dual supplies is " $W = I_{CC} \times 2 \times V^+ + 1.62 \times (V^+ \times V^- + (2 \times R_L))$ ".

(Calculation type condition: Loads connected with an individual output terminal are this all characteristics, and it is assumed same resistance  $R_L$ )

(Note 6) Refer to following Figure 1 for a permissible loss when ambient temperature ( $T_a$ ) is  $T_a \geq 25^\circ\text{C}$ .

FIGURE1: Power Dissipation vs. Ambient Temperature

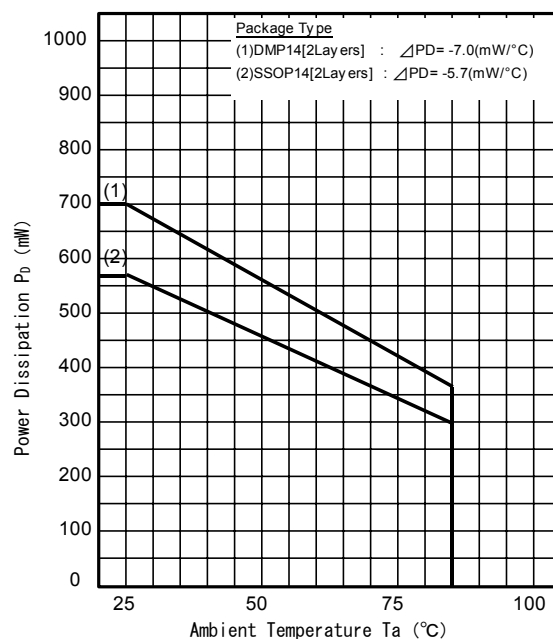

## ■ ELECTRIC CHARACTERISTICS

### ● DC CHARACTERISTICS

(V+/V- = ±4.5V, Ta = 25°C)

PARAMETER	SYMBOL	TEST CONDITION	MIN.	TYP.	MAX.	UNIT
Supply Current	I <sub>CC</sub>	No Signal	-	12	16	mA
Input Offset Voltage	V <sub>IO</sub>	R <sub>S</sub> ≤ 10kΩ	-	0.3	3	mV
Input Bias Current	I <sub>B</sub>		-	100	500	nA
Input Offset Current	I <sub>IO</sub>		-	5	200	nA
Large Signal Voltage Gain	A <sub>V</sub>	R <sub>L</sub> ≥ 2kΩ, V <sub>o</sub> = ±1.5V	90	110	-	dB
Common Mode Rejection Ratio	CMR	R <sub>S</sub> ≤ 10kΩ, -2.5V ≤ V <sub>IC</sub> ≤ +2.5V	70	110	-	dB
Supply Voltage Rejection Ratio	SVR	R <sub>S</sub> ≤ 10kΩ, V <sup>+</sup> /V <sup>-</sup> = ±2 ~ ±7V	80	110	-	dB
Maximum Output Voltage	V <sub>OM</sub>	R <sub>L</sub> ≥ 2kΩ	±2.5	±3	-	V
Input Common Mode Voltage Range	V <sub>ICM</sub>	CMR ≥ 70dB	-2.5	-	+2.5	V

### ● AC CHARACTERISTICS

(V+/V- = ±4.5V, Ta = 25°C)

PARAMETER	SYMBOL	TEST CONDITION	MIN.	TYP.	MAX.	UNIT
Unity Gain Bandwidth	GB	f = 10kHz	-	15	-	MHz
Equivalent input Noise Voltage	V <sub>NI</sub>	R <sub>S</sub> = 0Ω	-	5	-	nV/√Hz
Total Harmonic Distortion	THD	V <sup>+</sup> /V <sup>-</sup> = ±9V, A <sub>V</sub> = 20dB, V <sub>o</sub> = 4Vrms R <sub>L</sub> = 2kΩ, f = 1kHz V <sup>+</sup> /V <sup>-</sup> = ±4.5V, A <sub>V</sub> = 20dB, V <sub>o</sub> = 1Vrms R <sub>L</sub> = 2kΩ, f = 1kHz	-	0.001	-	%

### ● TRANSIENT CHARACTERISTICS

(V+/V- = ±4.5V, Ta = 25°C)

PARAMETER	SYMBOL	TEST CONDITION	MIN.	TYP.	MAX.	UNIT
Slew Rate	SR	R <sub>L</sub> ≥ 2kΩ	-	5	-	V/μs

## ■ TYPICAL CHARACTERISTICS

Supply Current vs. Supply Voltage  
 $V_{IN}=0V, T_a=25^\circ C$

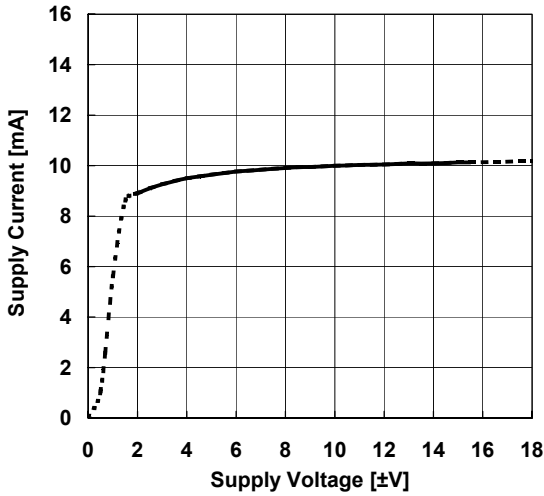

Supply Current vs. Ambient Temperature  
 (Supply Voltage)  
 $V_{IN}=0V$

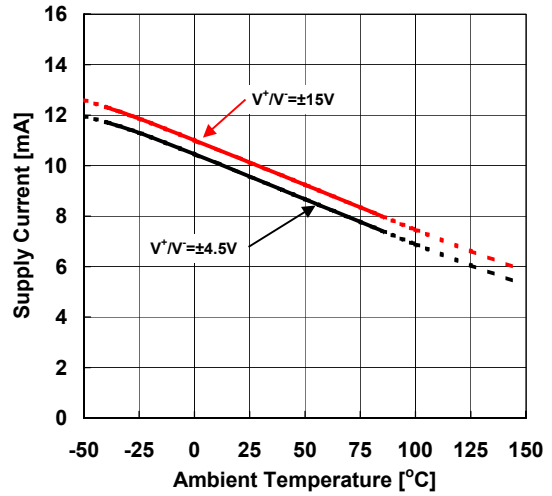

Input Offset Voltage vs. Supply Voltage  
 (Ambient Temperature)  
 $V_{ICM}=0V, R_S=10k\Omega$

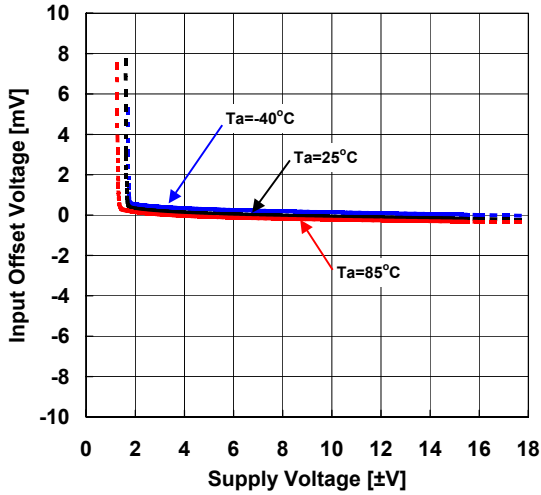

Input Offset Voltage vs. Ambient Temperature  
 $V^+/V^- = \pm 15V, V_{ICM}=0V$

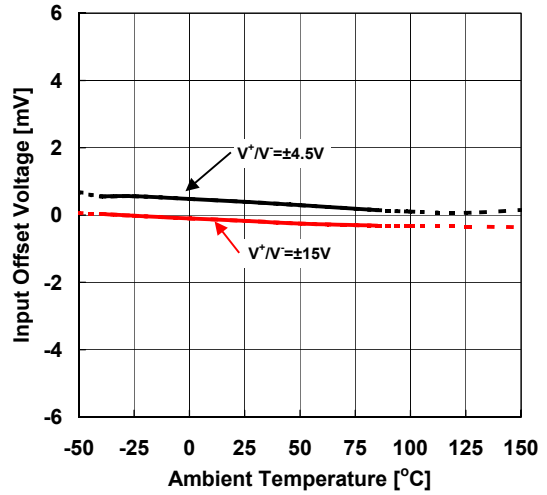

Input Offset Voltage  
 vs. Common Mode Input Voltage  
 (Ambient Temperature)  
 $V^+/V^- = \pm 15V, R_S=10k\Omega$

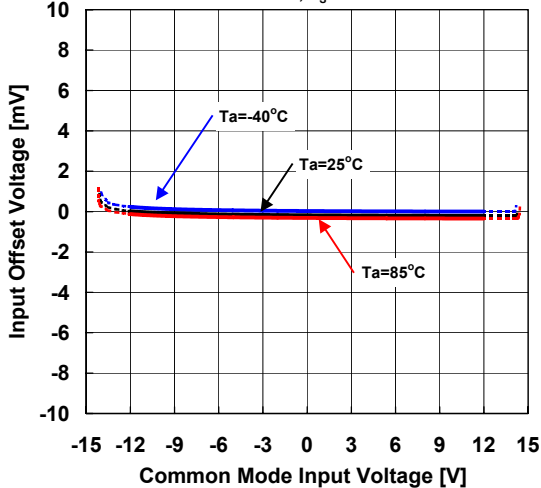

Input Offset Voltage  
 vs. Common Mode Input Voltage  
 $V^+/V^- = \pm 4.5V, R_S=10k\Omega, T_a=25^\circ C$

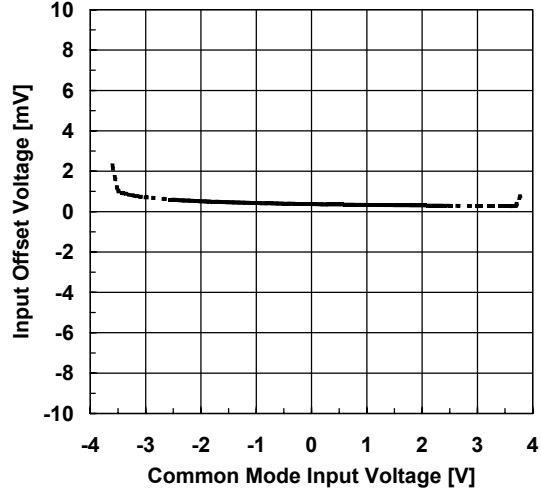

## ■ TYPICAL CHARACTERISTICS

Input Offset Current vs. Ambient Temperature  
 $V_{ICM}=0V, R_S=50k\Omega$

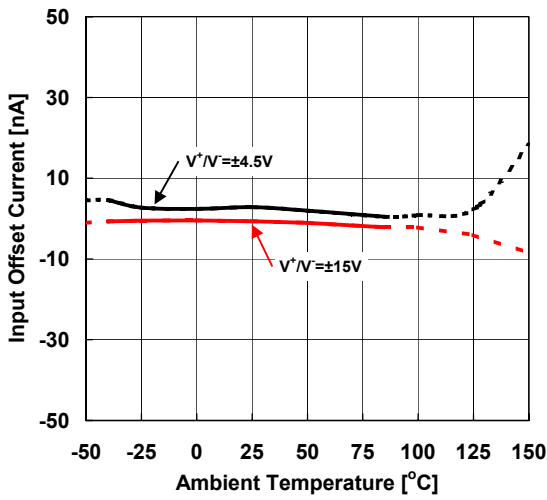

Input Bias Current vs. Ambient Temperature  
 $V_{ICM}=0V, R_S=10k\Omega$

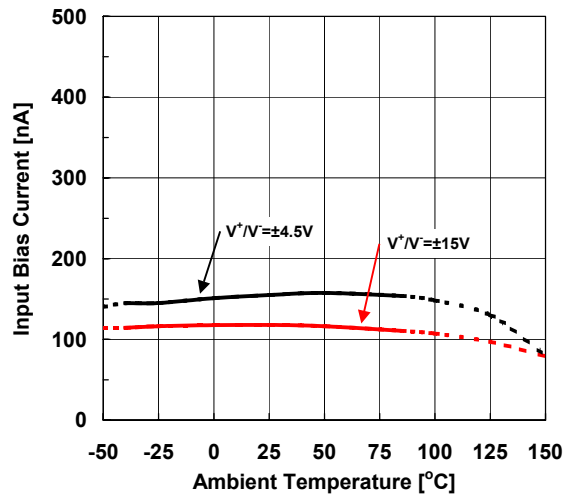

Common Mode Rejection Ratio vs. Ambient Temperature  
 $R_S=10k\Omega$

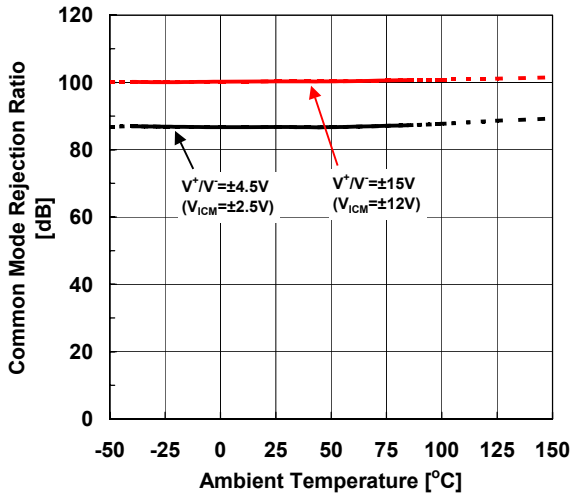

Supply Voltage Rejection Ratio vs. Ambient Temperature  
 $R_S=10k\Omega$

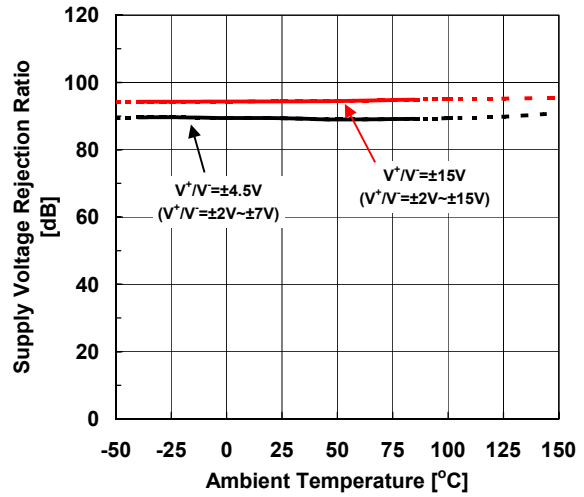

Voltage Gain vs. Ambient Temperature  
 $R_L=2k\Omega$

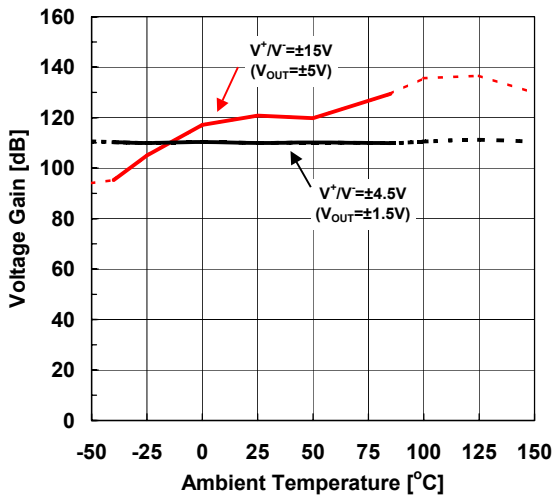

Maximum Output Voltage vs. Supply Voltage  
 $V_{IN+}=\pm 1V, V_{IN-}=0V, R_L=10k\Omega, T_a=25^\circ C$

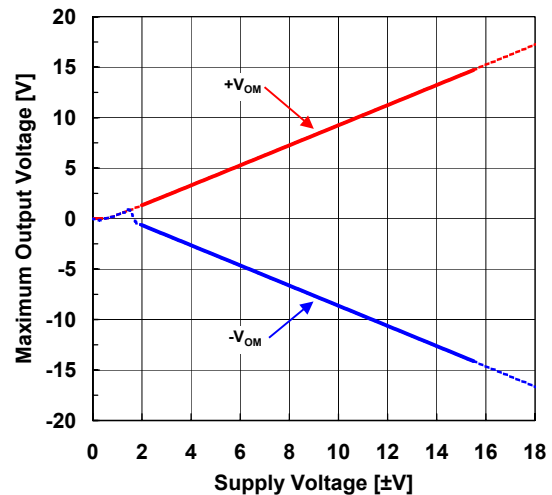

## ■ TYPICAL CHARACTERISTICS

Maximum Output Voltage vs. Ambient Temperature

$V^+ / V^- = \pm 15V$ ,  $V_{IN} = \pm 1V$ ,  $V_{IN} = 0V$ ,  $R_L = 2k\Omega$

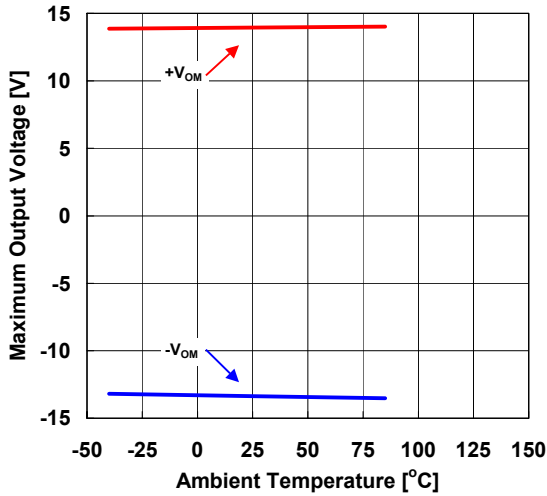

Maximum Output Voltage vs. Ambient Temperature

$V^+ / V^- = \pm 4.5V$ ,  $V_{IN} = \pm 1V$ ,  $R_L = 2k\Omega$

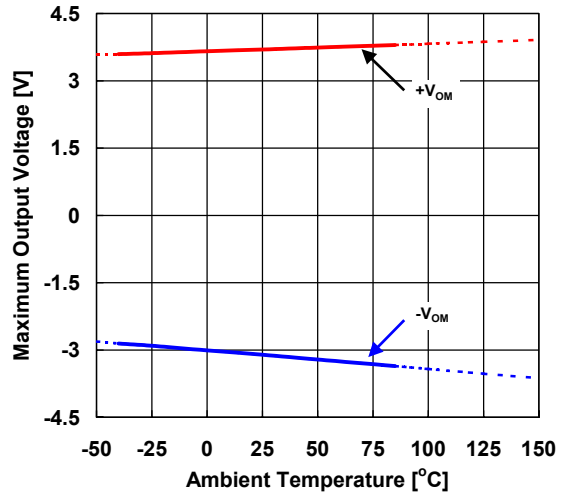

Maximum Output Voltage vs. Load Resistance  
(Ambient Temperature)

$V^+ / V^- = \pm 15V$ ,  $V_{IN} = \pm 1V$ ,  $V_{IN} = 0V$

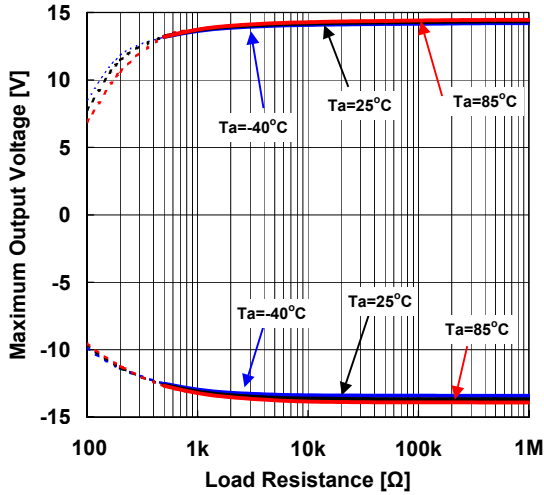

Maximum Output Voltage vs. Load Resistance

$V^+ / V^- = \pm 4.5V$ ,  $V_{IN} = \pm 1V$ ,  $T_a = 25^\circ C$

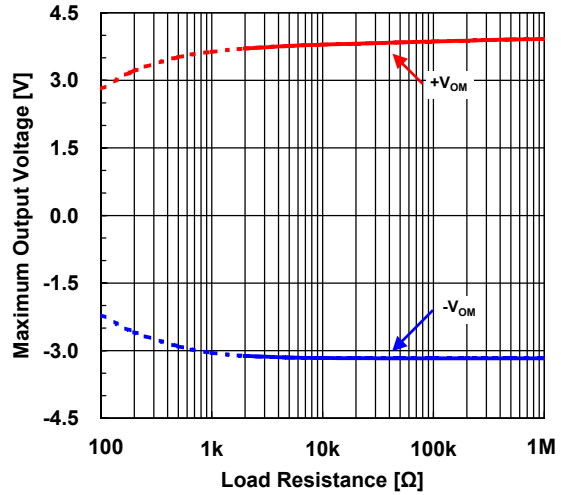

Maximum Output Voltage vs. Load Current

$V^+ / V^- = \pm 15V$ ,  $V_{IN} = \pm 1V$ ,  $V_{IN} = 0V$ ,  $T_a = 25^\circ C$

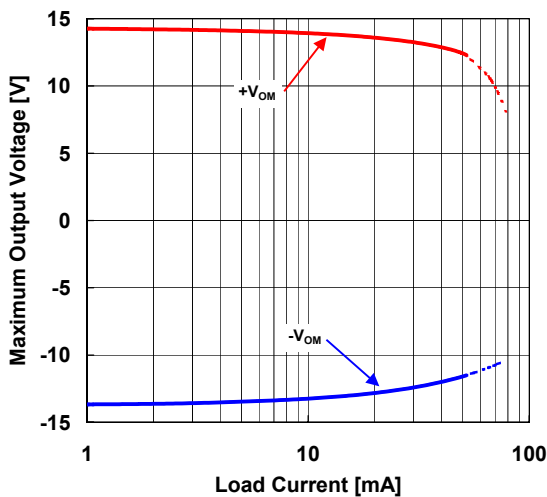

Maximum Output Voltage vs. Load Current

$V^+ / V^- = \pm 4.5V$ ,  $V_{IN} = \pm 1V$ ,  $T_a = 25^\circ C$

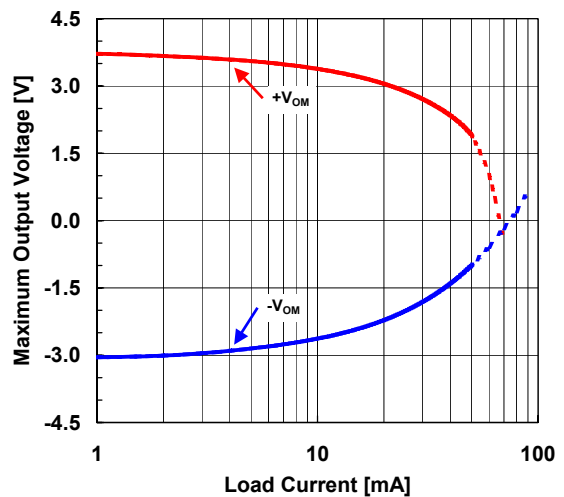

## ■ TYPICAL CHARACTERISTICS

**40dB Gain/Phase vs. Frequency (Ambient Temperature)**

$V^+/V^- = \pm 15V$ ,  $G_V = 40dB$ ,  $R_I = 50\Omega$ ,  $R_L = 2k\Omega$ ,  $C_L = 15pF$

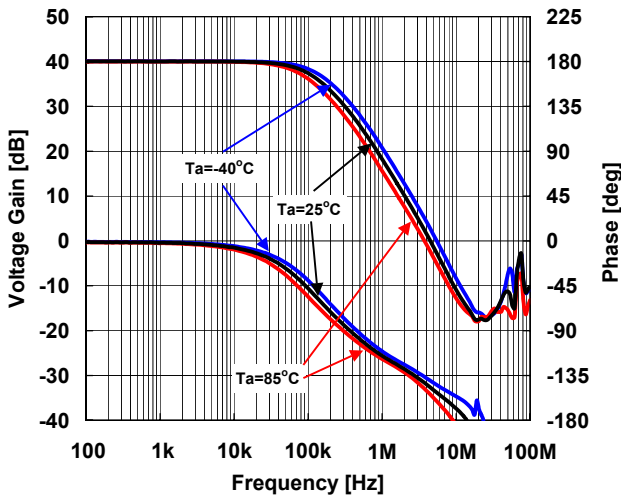

**40dB Gain/Phase vs. Frequency (Load Capacitance)**

$V^+ / V^- = \pm 15V$ ,  $G_V = 40dB$ ,  $R_I = 50\Omega$ ,  $R_L = 2k\Omega$ ,  $T_a = 25^\circ C$

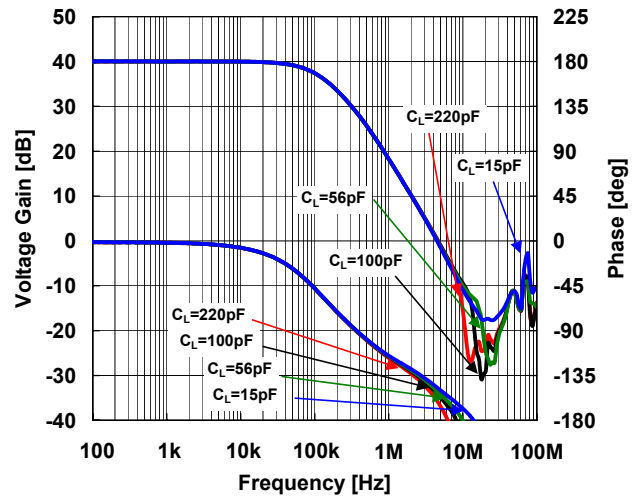

**40dB Gain/Phase vs. Frequency (Ambient Temperature)**

$V^+ / V^- = \pm 4.5V$ ,  $G_V = 40dB$ ,  $R_L = 2k\Omega$ ,  $C_L = 10pF$

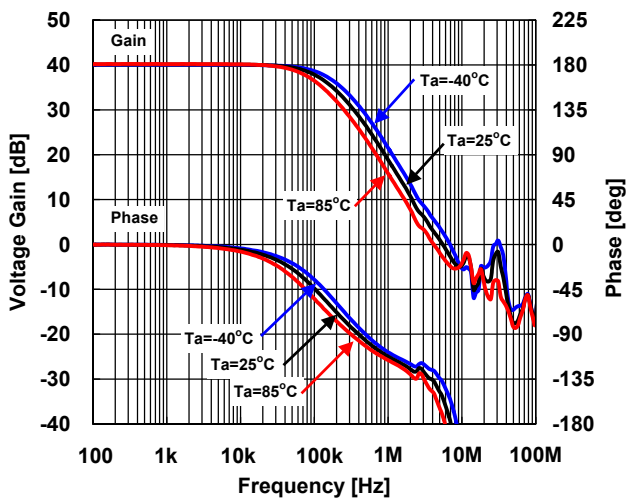

**40dB Gain/Phase vs. Frequency (Load Capacitance)**

$V^+ / V^- = \pm 4.5V$ ,  $G_V = 40dB$ ,  $R_L = 2k\Omega$ ,  $T_a = 25^\circ C$

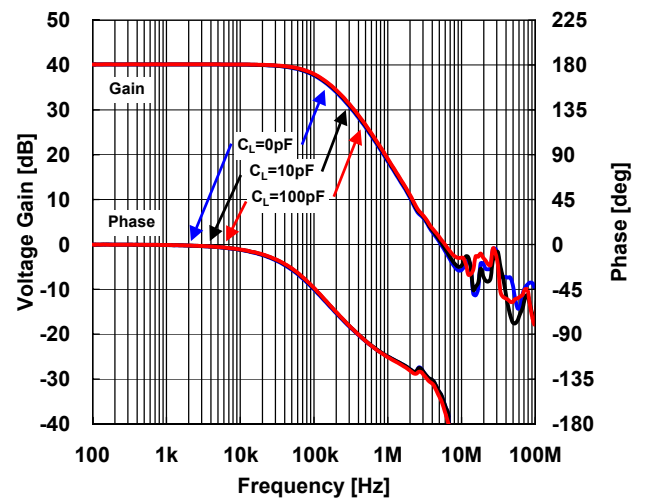

**V.F. Peak vs. Frequency (Ambient Temperature)**

$V^+ / V^- = \pm 4.5V$ ,  $G_V = 0dB$ ,  $R_L = 2k\Omega$ ,  $C_L = 10pF$

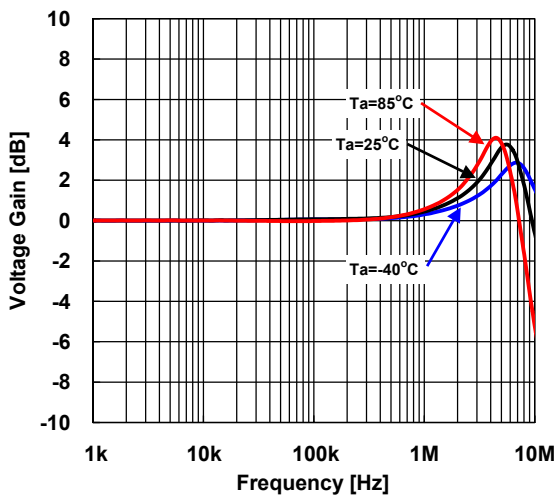

**V.F. Peak vs. Frequency (Load Capacitance)**

$V^+ / V^- = \pm 4.5V$ ,  $G_V = 0dB$ ,  $R_L = 2k\Omega$ ,  $T_a = 25^\circ C$

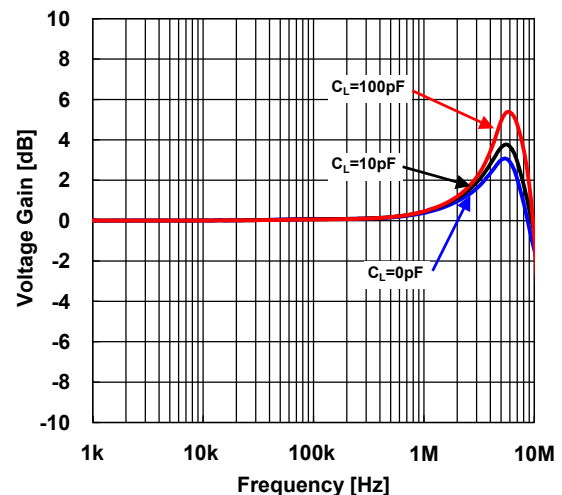

## ■ TYPICAL CHARACTERISTICS

**Pulse Response (Ambient Temperature)**

$V^*/V = \pm 15V$ ,  $V_{IN} = 10V_{PP}$ ,  $f_{IN} = 1kHz$ ,  $G_v = 0dB$ ,  
 $R_T = 50\Omega$ ,  $R_L = 50k\Omega$ ,  $C_L = 15pF$

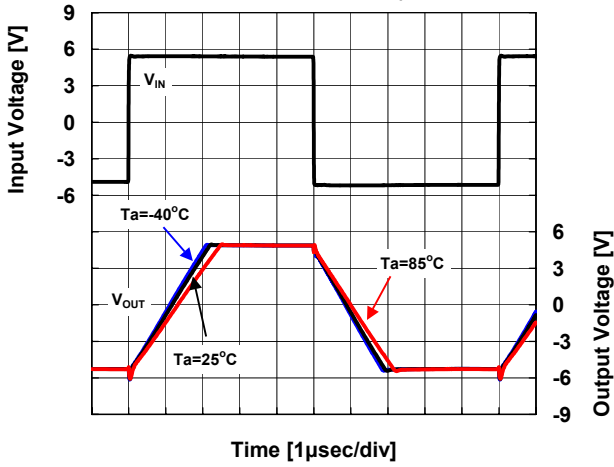

**Pulse Response (Load Resistance)**

$V^*/V = \pm 15V$ ,  $V_{IN} = 10V_{PP}$ ,  $f_{IN} = 1kHz$ ,  $G_v = 0dB$ ,  
 $R_T = 50\Omega$ ,  $C_L = 15pF$ ,  $T_a = 25^\circ C$

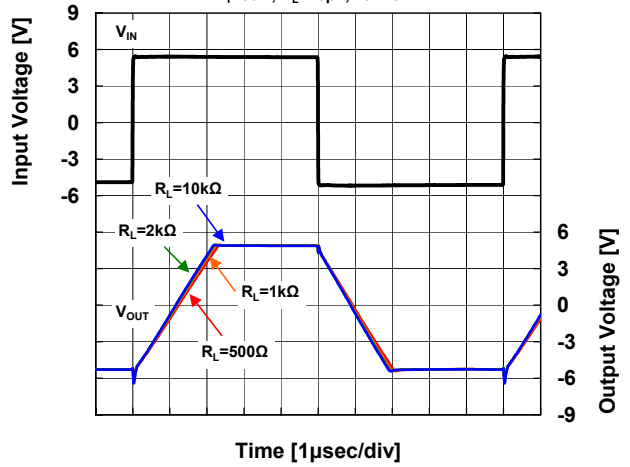

**Pulse Response (Load Capacitance)**

$V^*/V = \pm 15V$ ,  $V_{IN} = 10V_{PP}$ ,  $f_{IN} = 1kHz$ ,  $G_v = 0dB$ ,  
 $R_T = 50\Omega$ ,  $R_L = 50k\Omega$ ,  $T_a = 25^\circ C$

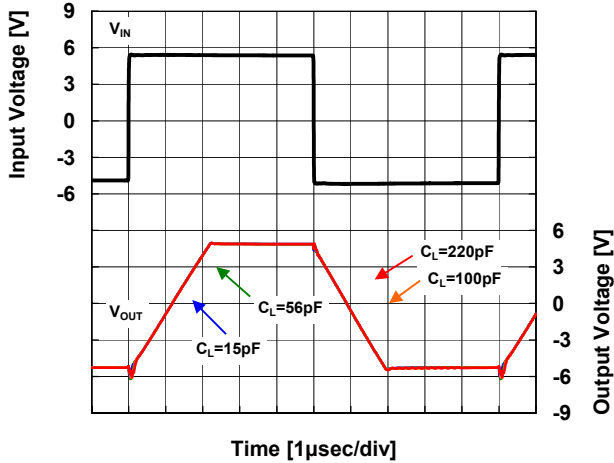

**Pulse Response (Ambient Temperature)**

$V^*/V = \pm 4.5V$ ,  $V_{IN} = \pm 2.5V$ ,  
 $f_{IN} = 1kHz$ ,  $G_v = 0dB$ ,  $R_L = 2k\Omega$ ,  $C_L = 10pF$

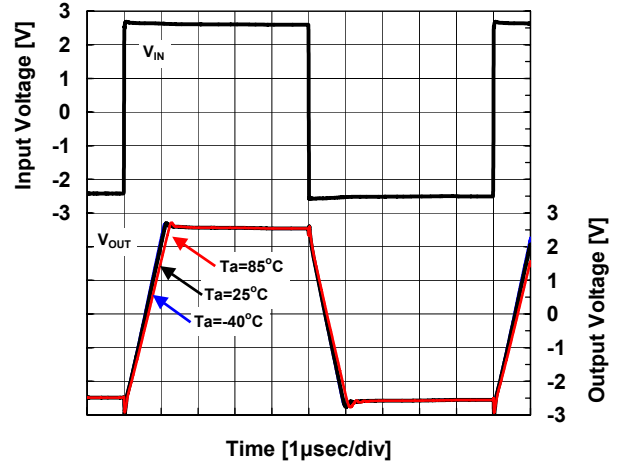

**Pulse Response (Load Capacitance)**

$V^*/V = \pm 4.5V$ ,  $V_{IN} = \pm 2.5V$ ,  
 $f_{IN} = 1kHz$ ,  $G_v = 0dB$ ,  $R_L = 2k\Omega$ ,  $T_a = 25^\circ C$

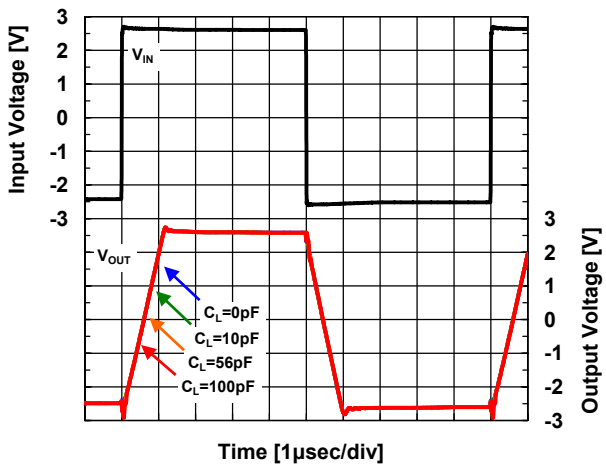



## ■ TYPICAL CHARACTERISTICS

**Slew Rate vs. Ambient Temperature**

$V^+/V^-=\pm 15V$ ,  $V_{in}=10V_{pp}$ ,  $f_{in}=1kHz$ ,  $G_V=0dB$ ,  
 $R_T=50\Omega$ ,  $R_L=2k\Omega$ ,  $C_L=15pF$

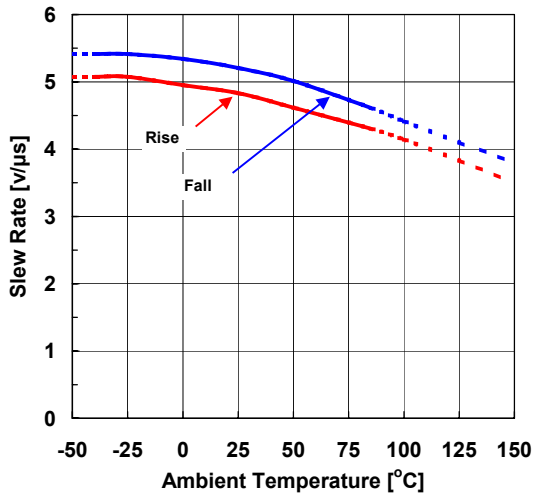

**Equivalent Input Noise Voltage**

$R_S=50\Omega$ ,  $R_L=100k\Omega$ ,  $G_V=60dB$ ,  $T_a=25^\circ C$

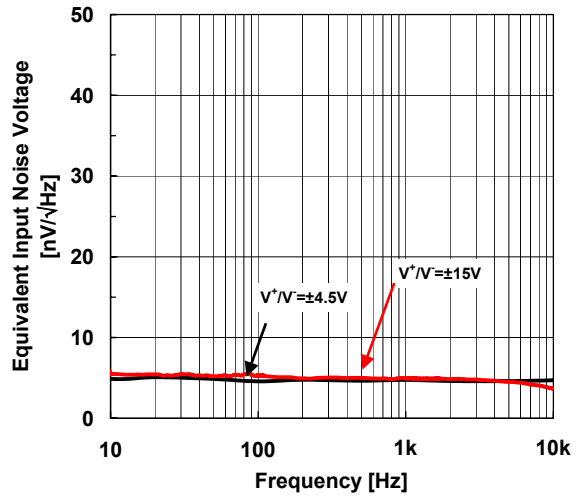

**THD+N vs. Output Voltage**

$V^+/V^-=\pm 15V$ ,  $G_V=20dB$ ,  $R_L=2k\Omega$ ,  $T_a=25^\circ C$

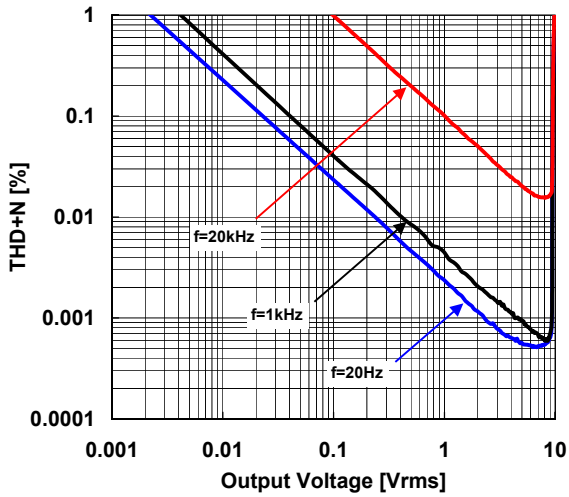

**THD+N vs. Output Voltage**

$V^+/V^-=\pm 4.5V$ ,  $G_V=20dB$ ,  $R_L=2k\Omega$ ,  $T_a=25^\circ C$

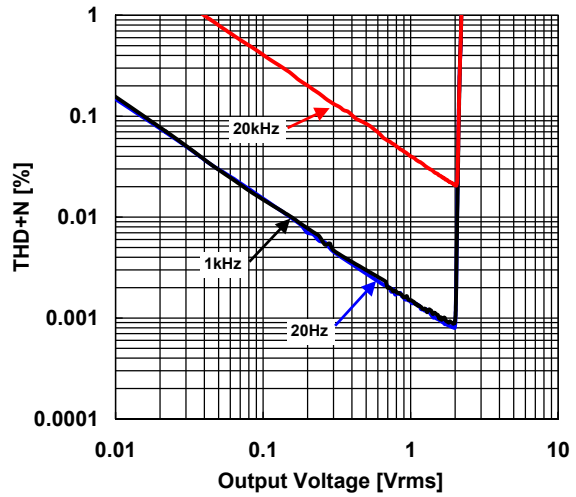

## ■ MEMO

[CAUTION]  
The specifications on this databook are only given for information, without any guarantee as regards either mistakes or omissions. The application circuits in this databook are described only to show representative usages of the product and not intended for the guarantee or permission of any right including the industrial rights.