

SINGLE-SUPPLY QUAD COMPARATOR

■ GENERAL DESCRIPTION

The NJM2901C consist of four independent voltage comparators that are designed specifically to operate from a single power supply over a wide range of voltages. Operation from split power supplies is also possible and the low power supply current drain is independent of the magnitude of the power supply voltage. The NJM2901C has a unique characteristic: the input common-mode voltage range includes ground, even though operated from a single power supply voltage. Application areas include limit comparators, simple analog-to-digital converters; pulse, square-wave and time delay generators; wide range V_{CO} ; MOS clock timers; multivibrators and high voltage digital logic gates. The NJM2901C were designed to directly interface with TTL and MOS. When operated from both plus and minus power supplies, the NJM2901C will directly interface with MOS logic where their low power drain is a distinct advantage over standard comparators.

■ PACKAGE OUTLINE

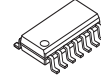

NJM2901CG
(SOP14)

■ FEATURES

- Operating Voltage +2V to +36V
- Single Supply Operation
- Open Collector Output
- Package Outline SOP14
- Bipolar Technology
- Internal ESD protection
Human body model (HBM) $\pm 2000V$ typ.
- Wide temperature range -40°C to +105°C

■ PIN CONFIGURATION

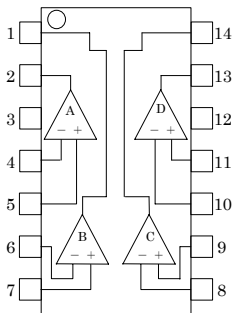

NJM2901C

PIN FUNCTION

- | | |
|----------------------------|-----------------------------|
| 1. B OUTPUT | 8. C—INPUT |
| 2. A OUTPUT | 9. C +INPUT |
| 3. V^+ | 10. D—INPUT |
| 4. A—INPUT | 11. D +INPUT |
| 5. A +INPUT | 12. V^- |
| 6. B—INPUT | 13. D OUTPUT |
| 7. B +INPUT | 14. C OUTPUT |

■ EQUIVALENT CIRCUIT (1/4Shown)

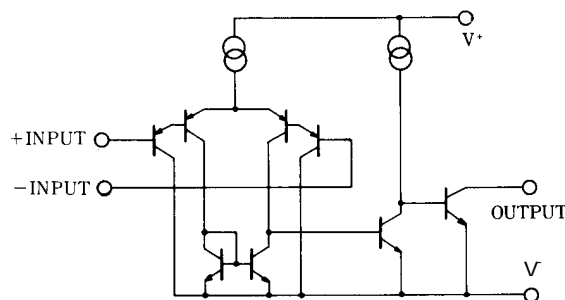

NJM2901C

■ ABSOLUTE MAXIMUM RATINGS

(Ta=25°C)

PARAMETER	SYMBOL	RATINGS	UNIT
Supply Voltage	V^+ (V^+/V)	36 (or $\pm 18V$)	V
Differential Input Voltage (Note1)	V_{ID}	± 36	V
Input Voltage (Note2)	V_{IN}	$V - 0.3$ to $V + 36$	V
Output Terminal Input Voltage (Note3)	V_O	$V - 0.3$ to $V + 36$	V
Power Dissipation	P_D	SOP : 880(Note4) 1200(Note5)	mW
Operating Temperature Range	T_{opr}	-40 to +105	°C
Storage Temperature Range	T_{stg}	-65 to +150	°C

(Note1) It can be applied to the input terminals regardless of the supply voltage and must be less than the rating voltage.

(Note2) Input voltage is the voltage should be allowed to apply to the input terminal independent of the magnitude of V^+

(Note3) Output voltage is the voltage should be allowed to apply to the output terminal independent of the magnitude of V^+ .

(Note4) EIA/JEDEC STANDARD Test board (76.2 x 114.3 x 1.6mm, 2layers, FR-4) mounting

(Note5) EIA/JEDEC STANDARD Test board (76.2 x 114.3 x 1.6mm, 4layers, FR-4) mounting

■ ELECTRICAL CHARACTERISTICS

($V^+=5V, V^-=0V, Ta=25^\circ C$ unless otherwise noted.)

Parameter	Symbol	Test Condition	Min.	Typ.	Max.	Unit
Input offset voltage	V_{IO}	$R_S=0\Omega, V_O=1.4V$	-	0.5	5	mV
Input offset current	I_{IO}		-	0.5	50	nA
Input bias current	I_B		-	20	250	nA
Large signal voltage gain	A_V	$V^+=15V, R_L=15k\Omega, V_O=1V$ to 11V	94	106	-	dB
Input Common Mode Voltage Range	V_{ICM}		0	-	3.5	V
Supply current (all comparators)	I_{CC}	no load $V^+=+30V$, no load	-	0.8 1.1	2 2.5	mA
Low level output voltage	V_{OL}	$V_{id} = -1V, I_{sink} = 4mA$	-	160	400	mV
Output Leakage Current	I_{LEAK}	$V^+=V_O=30V, V_{id}=1V$	-	-	1	μA
Output sink current	I_{sink}	$V_{id}=1V, V_O=1.5V$	6	16	-	mA
Response Time	t_{re}	$R_L=5.1k\Omega$ to V^+	-	1.3	-	μs
Large Signal Response Time	t_{rel}	$R_L=5.1k\Omega$ to V^+ , $V_{ref}=+1.4V$, TTL input	-	250	-	ns

■ TYPICAL CHARACTERISTICS

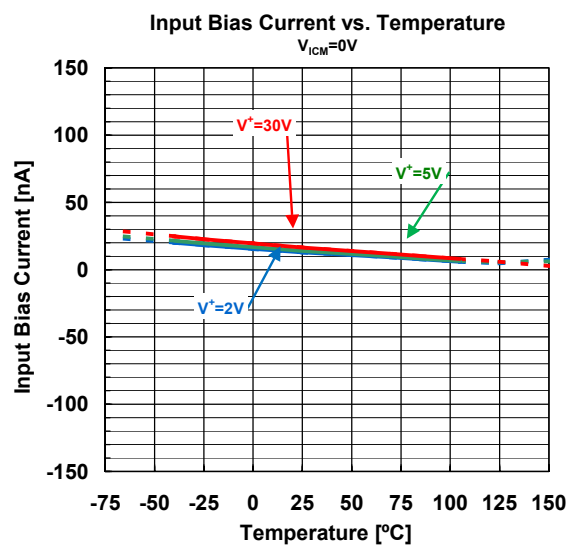
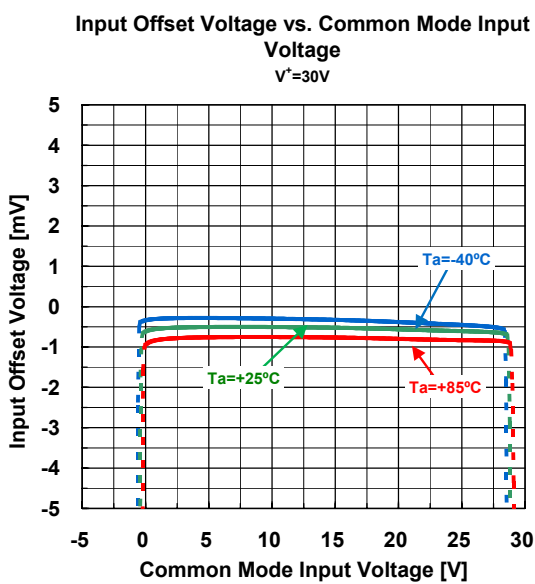
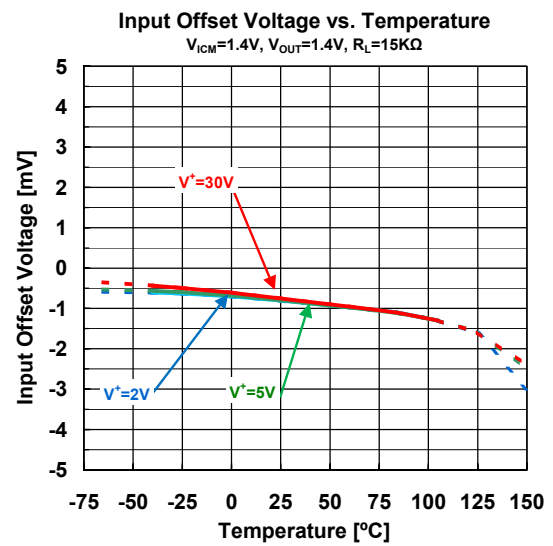
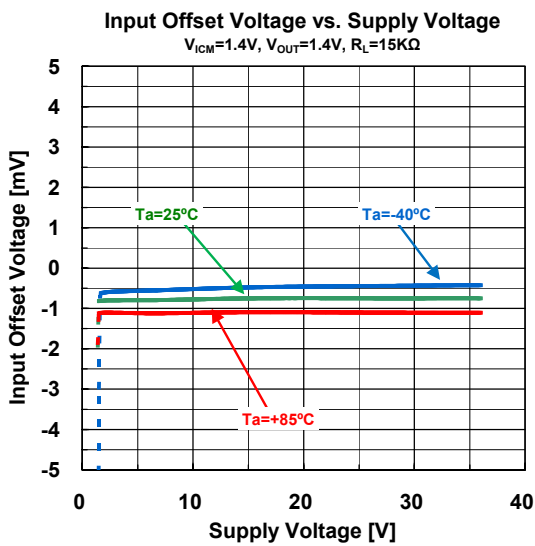
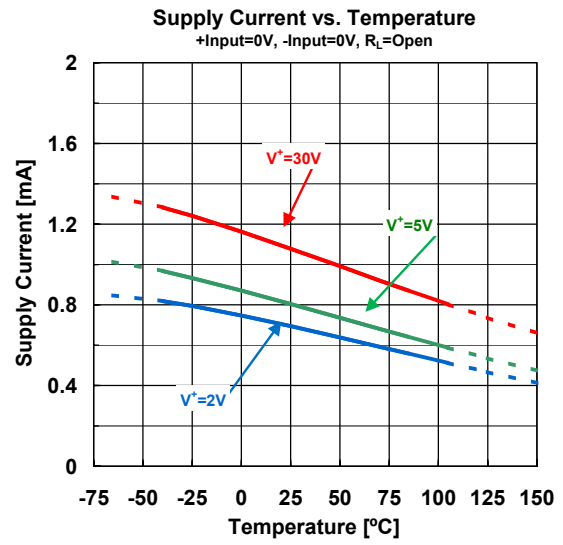
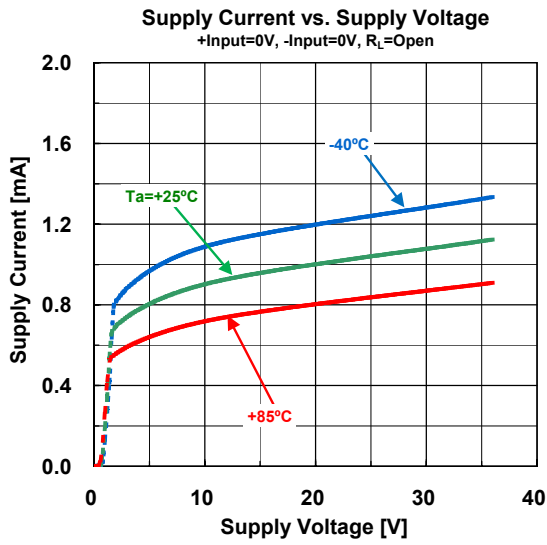

Open Loop Gain vs. Temperature

$V^+ = 15V, V_{OUT} = 1V \text{ to } 11V$

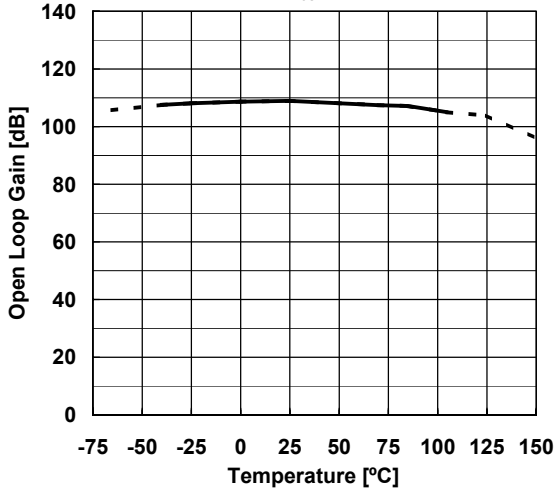

Sink Current vs. Temperature

$V_{OUT} = 1.5V, +Input = 0V, -Input = 1V$

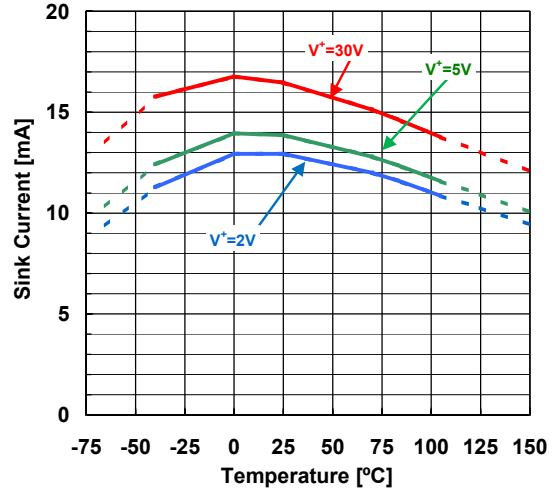

Saturation Voltage vs. Sink Current

$V^+ = 5V, +Input = 0V, -Input = 1V$

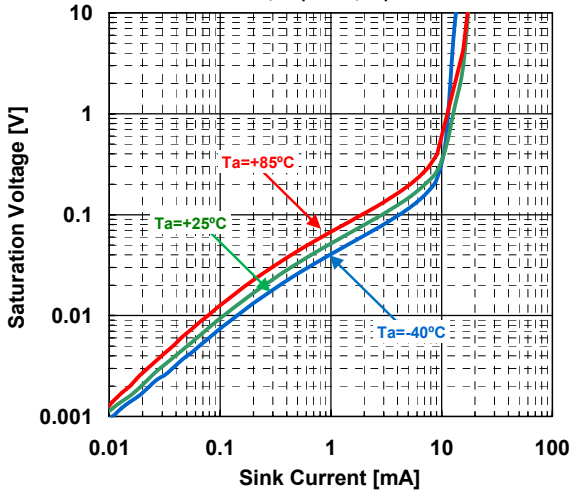

Saturation Voltage vs. Temperature

$V^+ = 5V, +Input = 0V, -Input = 1V, I_{OUT} = 3mA$

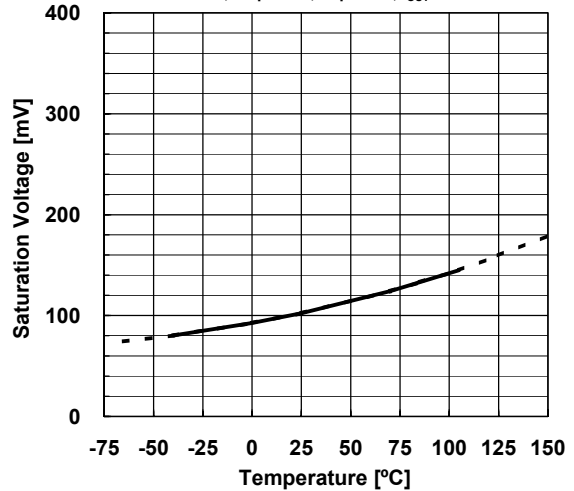

Propagation Delay Time vs. Temperature

$V^+ = 5V, V_{IN+} = GND, V_{IN-} = 200mV_{PP}, ov = 100mV, R_L = 5.1k\Omega$

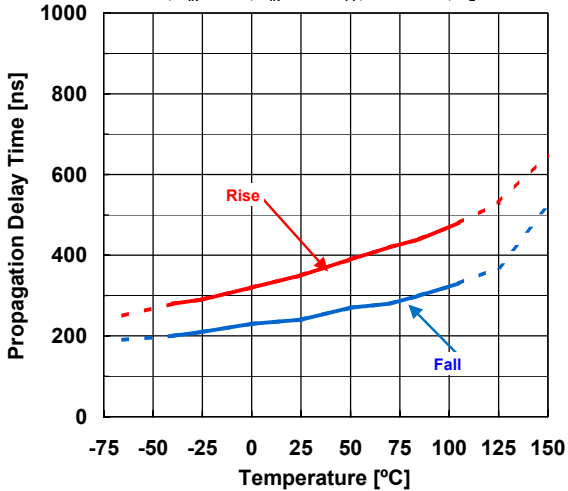

Response Time vs. Temperature

$V^+ = 5V, V_{IN+} = GND, V_{IN-} = 200mV_{PP}, ov = 100mV, R_L = 5.1k\Omega$

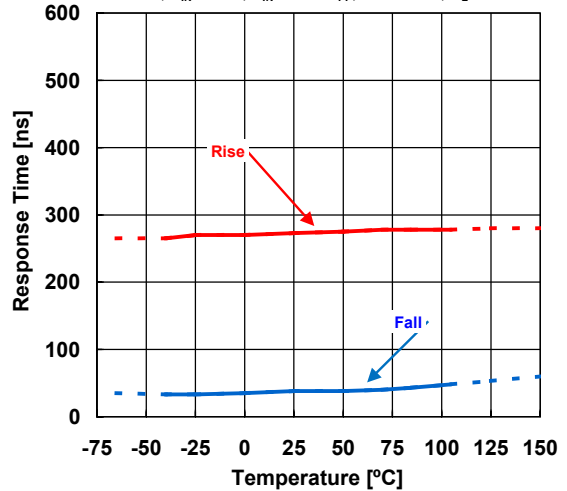

Propagation Delay Time

$V^+=5V$, $R_L=5.1k\Omega$, $V_{REF}=GND$, $C_L=0pF$, $T_a=25^\circ C$

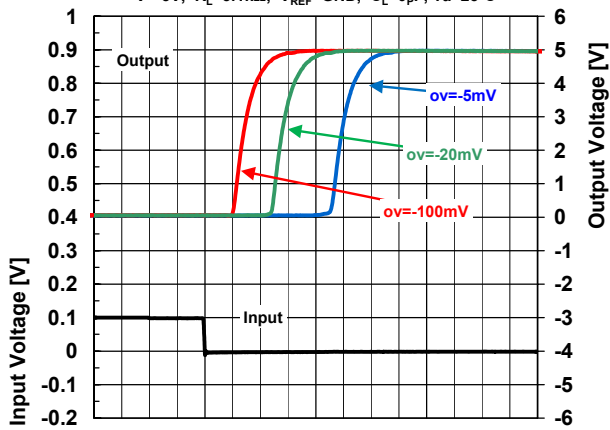

0.25 μs /div

Propagation Delay Time

$V^+=5V$, $R_L=5.1k\Omega$, $V_{REF}=GND$, $C_L=0pF$, $T_a=25^\circ C$

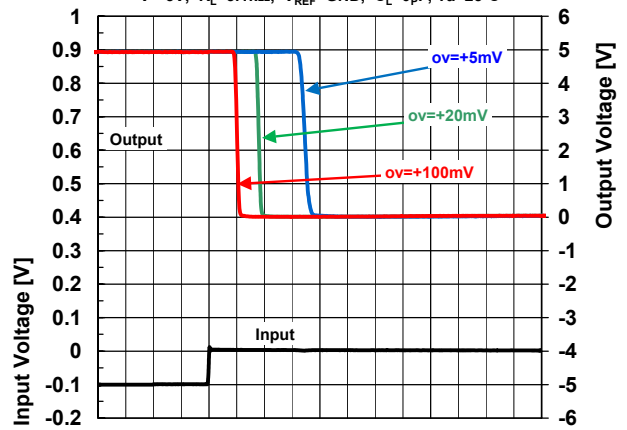

0.25 μs /div

Large Signal Propagation Delay Time

$V^+=5V$, $R_L=5.1k\Omega$, $V_{REF}=1.4V$, $T_a=25^\circ C$

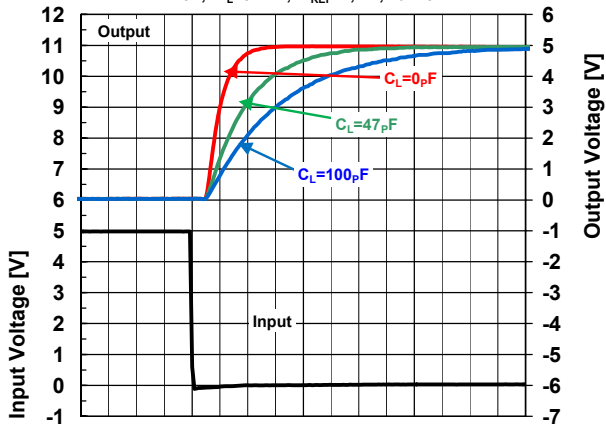

0.25 μs /div

Large Signal Propagation Delay Time

$V^+=5V$, $R_L=5.1k\Omega$, $V_{REF}=1.4V$, $T_a=25^\circ C$

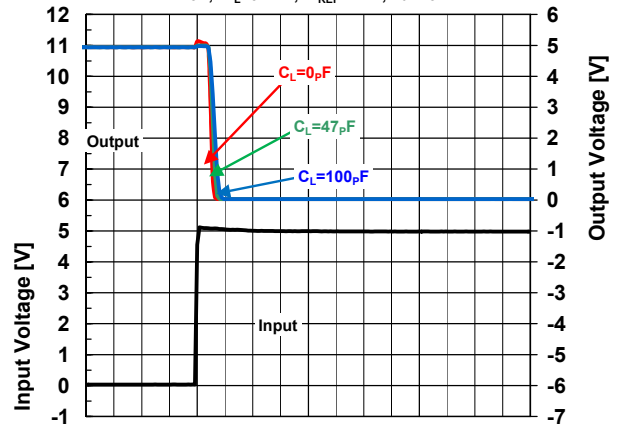

0.25 μs /div

NJM2901C

■PACKAGE OUTLINE UNIT : mm

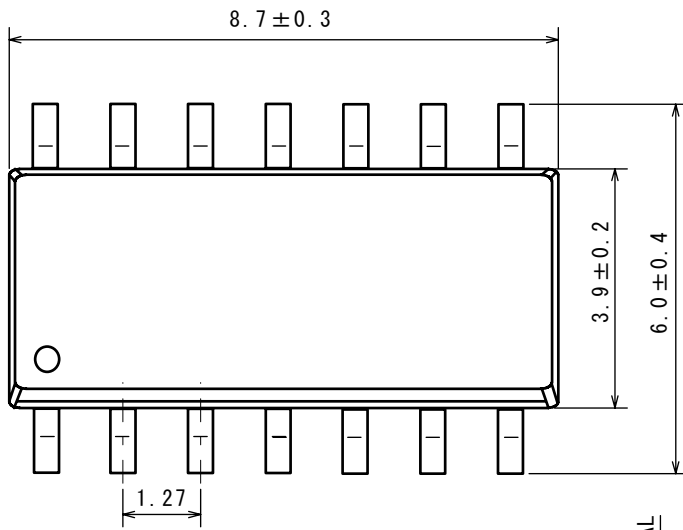

UNIT: mm

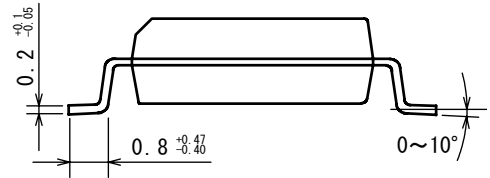
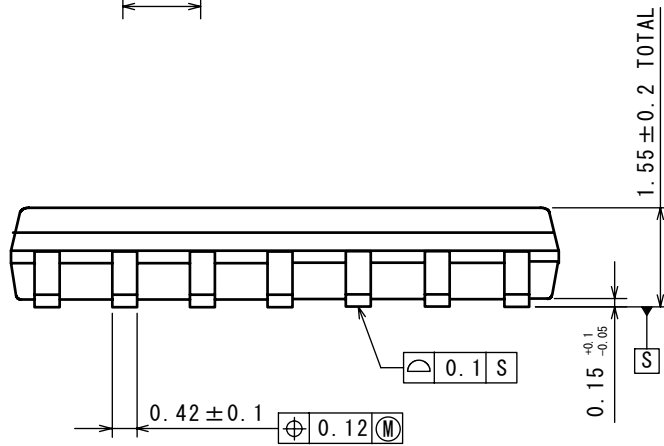

[CAUTION]
 The specifications on this databook are only given for information, without any guarantee as regards either mistakes or omissions. The application circuits in this databook are described only to show representative usages of the product and not intended for the guarantee or permission of any right including the industrial rights.