

LOW DROPOUT VOLTAGE REGULATOR WITH ON/OFF CONTROL

■ GENERAL DESCRIPTION

The NJM2396 is low dropout voltage regulator with ON/OFF control.

The output current is up to 1.5A and dropout voltage is 0.2Vtyp. at $I_o=0.5A$.

The NJM2396 is suitable for power module, TV, Display, car stereo and low power applications.

■ PACKAGE OUTLINE

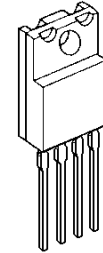

NJM2396F

■ FEATURE

- Low Dropout Voltage $\Delta V_{I-O}=0.2V$ typ. at $I_o=0.5A$
- Output Current $I_o(\text{max.})=1.5A$
- ON/OFF Control
- Internal Short Circuit Current Limit
- Internal Overvoltage Protection
- Internal Thermal Overload Protection
- Bipolar Technology
- Package Outline TO-220F-4

■ PIN CONFIGURATION

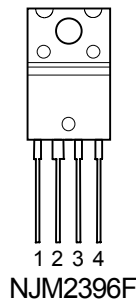

PIN FUNCTION

1. V_{IN}
2. V_{OUT}
3. GND
4. ON/OFF CONTROL

■ EQUIVALENT CIRCUIT

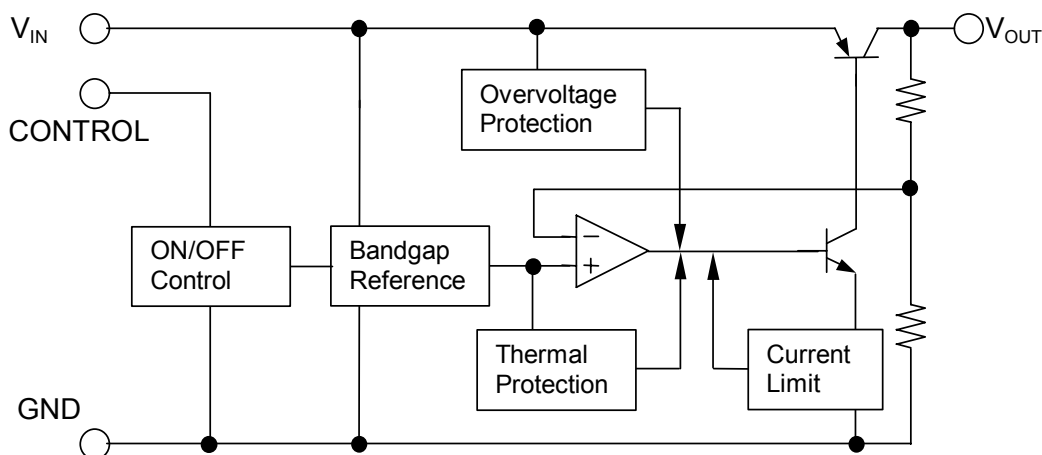

NJM2396

■ OUTPUT VOLTAGE RANK LIST

Device Name	V _{OUT}
NJM2396F33	3.3V
NJM2396F05	5.0V
NJM2396F63	6.3V
NJM2396F08	8.0V
NJM2396F83	8.3V
NJM2396F09	9.0V
NJM2396F12	12.0V

■ ABSOLUTE MAXIMUM RATINGS

(Ta=25°C)

PARAMETER	SYMBOL	RATINGS	UNIT
Input Voltage	V _{IN}	+35	V
Control Voltage	V _{CONT}	+35(*1)	V
Output Current	I _o	1.5	A
Power Dissipation	P _D	18(Tc<50°C)	W
Operating Junction Temperature Range	T _j	-40 to +150	°C
Operating Temperature Range	T _{opr}	-40 to 85	°C
Storage Temperature Range	T _{stg}	-50 to 150	°C

(*1): When input voltage is less than +35V, the absolute maximum control voltage is equal to the input voltage.

■ ELECTRICAL CHARACTERISTICS (V_{IN}=V_O+1V, I_o=0.5A, C_{IN}=0.33μF, C_o=22μF, T_j=25°C)

Measurement is to be conducted is pulse testing.

PARAMETER	SYMBOL	CONDITIONS	MIN.	TYP.	MAX.	UNIT
Output Voltage	V _o	V _{IN} =V _O +1V	-4%	-	+4%	V
Line Regulation	ΔV _o /ΔV _{IN}	V _{IN} =V _O +1V to V _O +17V	-	0.04	0.16	%/V
Load Regulation	ΔV _o /ΔI _o	V _{IN} =V _O +2V, I _o =0A to 1.5A	-	0.2	1.4	%/A
Average Temperature Coefficient of Output Voltage	ΔV _o /ΔT	T _j =0 to 125°C	-	±0.02	-	%/°C
Standby Current	I _Q	I _o =0A	-	-	5	mA
Dropout Voltage	ΔV _{I-O}	I _o =0.5A	-	0.2	0.5	V
Ripple Rejection	NJM2396F33	RR V _{IN} =V _O +2V e _{in} =0.5Vrms, f=120Hz	52	60	-	dB
	NJM2396F05		52	60	-	
	NJM2396F63		52	60	-	
	NJM2396F08		50	58	-	
	NJM2396F83		50	58	-	
	NJM2396F09		50	58	-	
	NJM2396F12		48	58	-	
ON Control Voltage	V _{CONT(ON)}		2.0(*2)	-	-	V
OFF Control Voltage	V _{CONT(OFF)}		-	-	0.4	V
ON Control Current	I _{CONT(ON)}	V _C =2.7V	-	-	20	μA
OFF Control Current	I _{CONT(OFF)}	V _C =0.4V	-	-	-20	μA

(*2): When ON/OFF CONTROL Terminal is open, Output Voltage is ON.

POWER DISSIPATION vs. AMBIENT TEMPERATURE

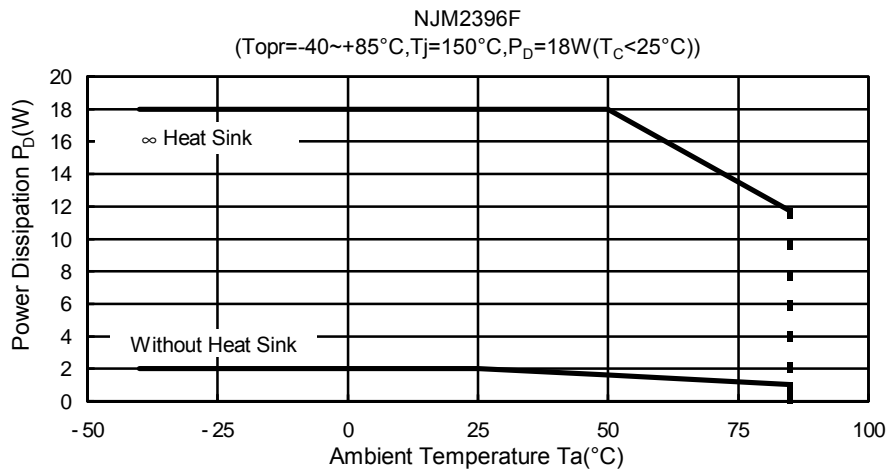

TEST CIRCUIT

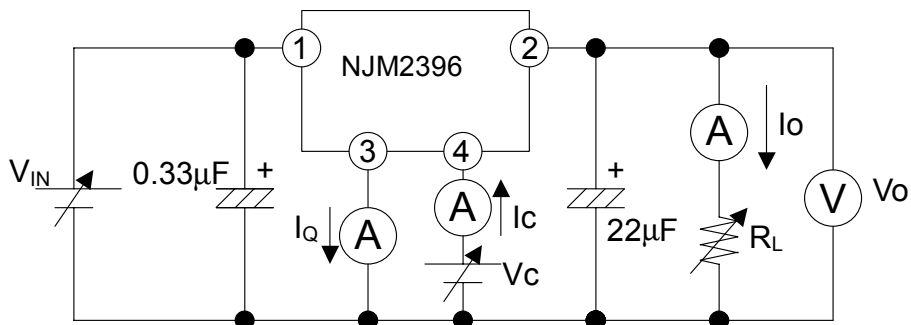

NJM2396

■ TYPICAL APPLICATION

① In the case where ON/OFF Control is not required:

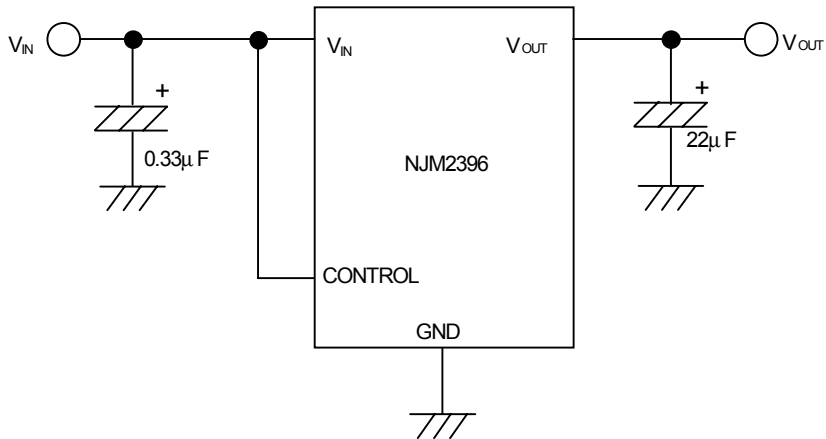

Connect control terminal to V_{IN} terminal or open.

② In use of ON/OFF CONTROL:

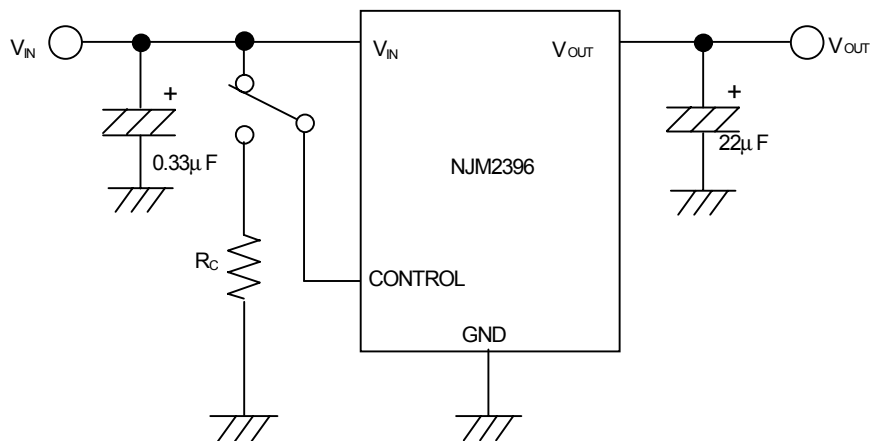

State of control terminal:

- “H” or “open” → output is enabled.
- “L” → output is disabled.

TYPICAL CHARACTERISTICS

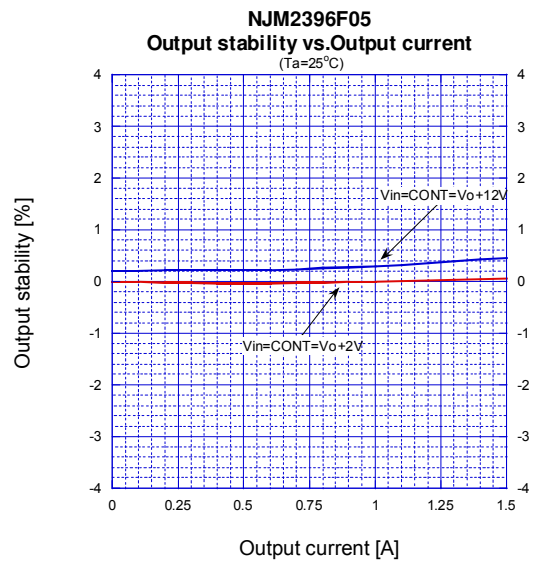
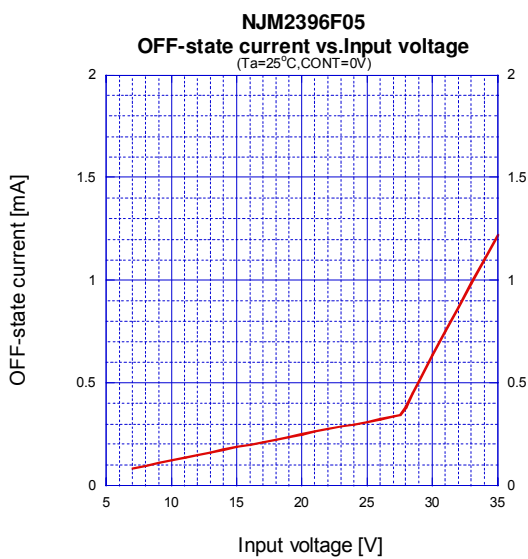
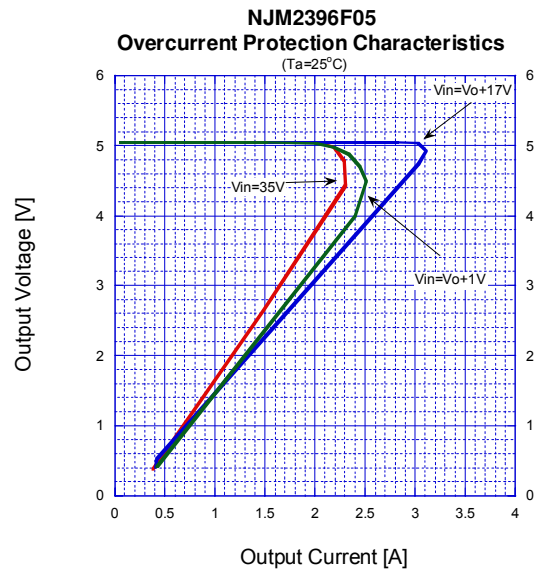
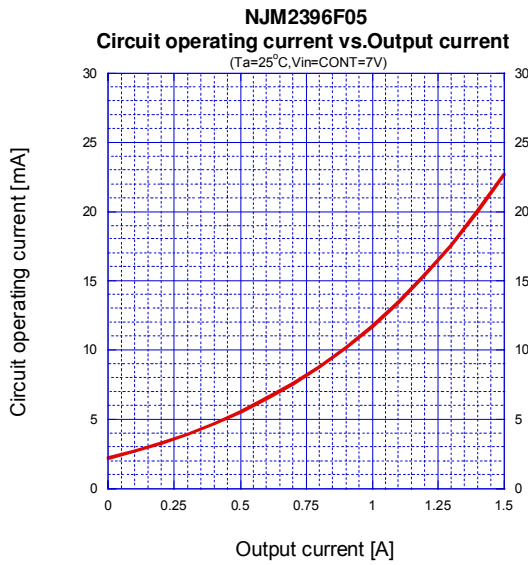
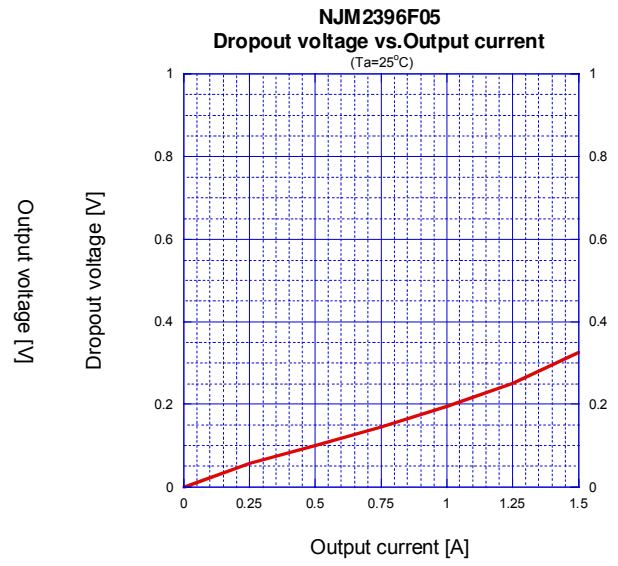
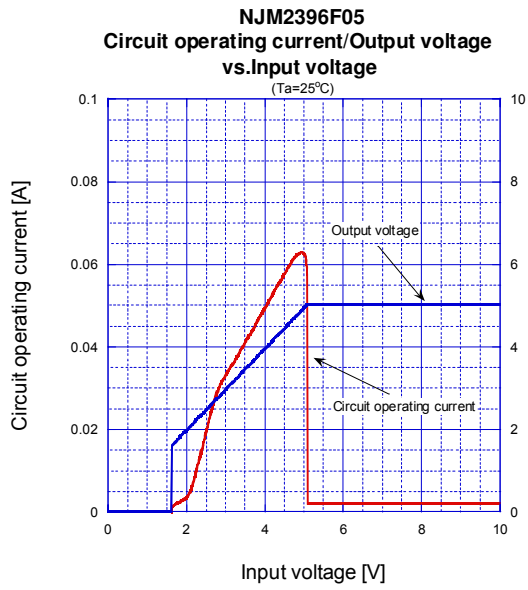

NJM2396

TYPICAL CHARACTERISTICS

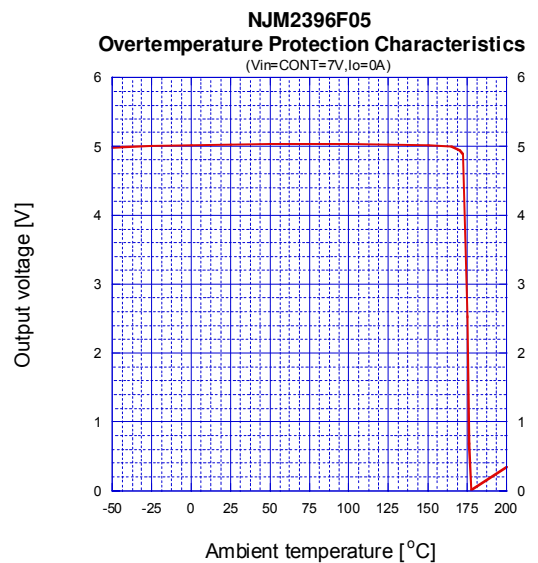
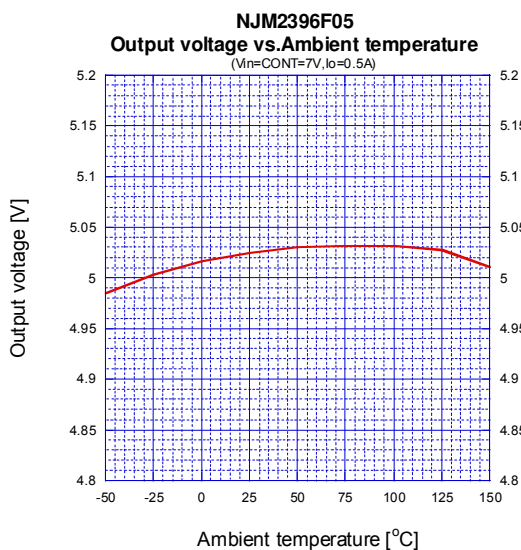
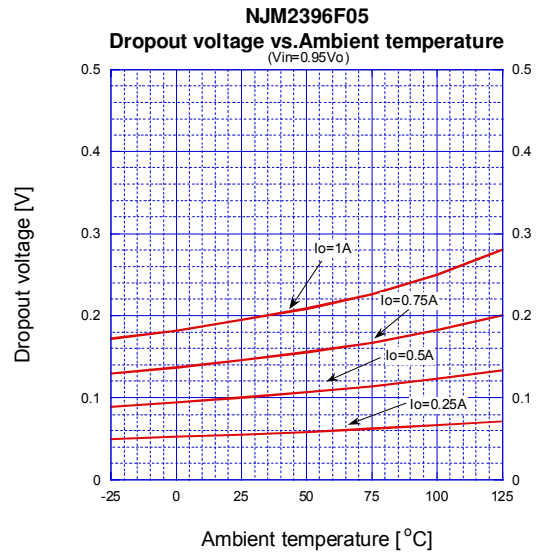
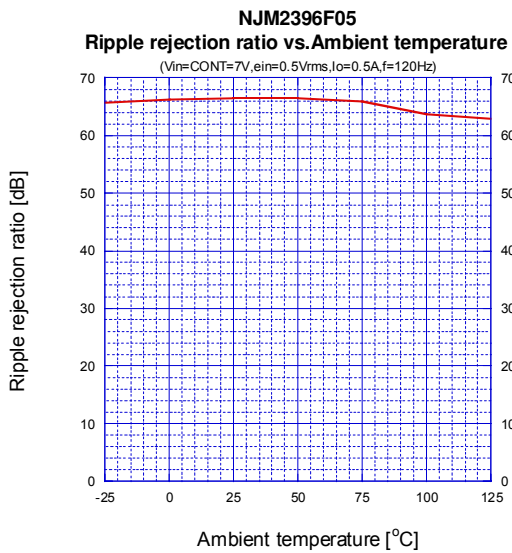
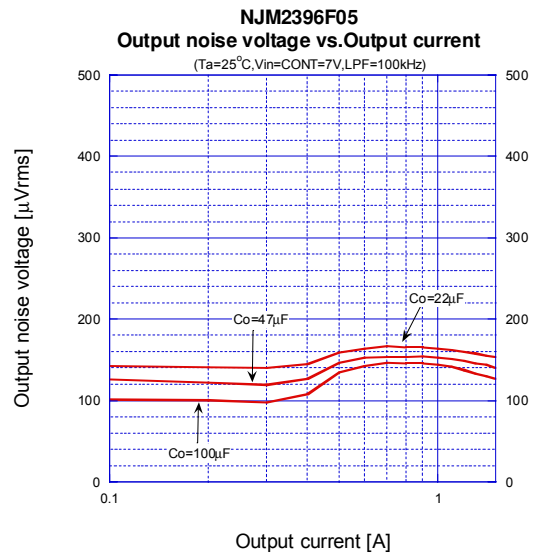
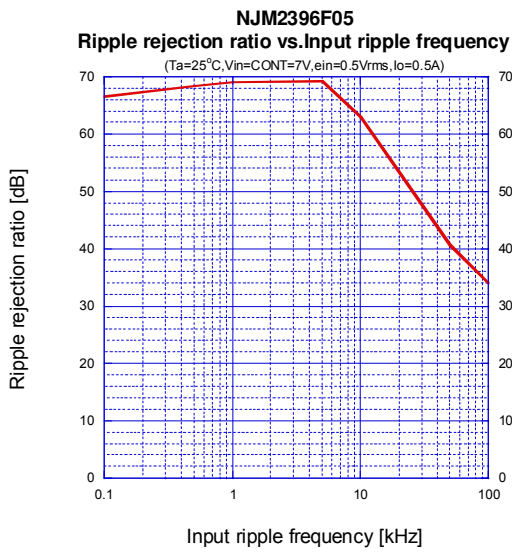

TYPICAL CHARACTERISTICS

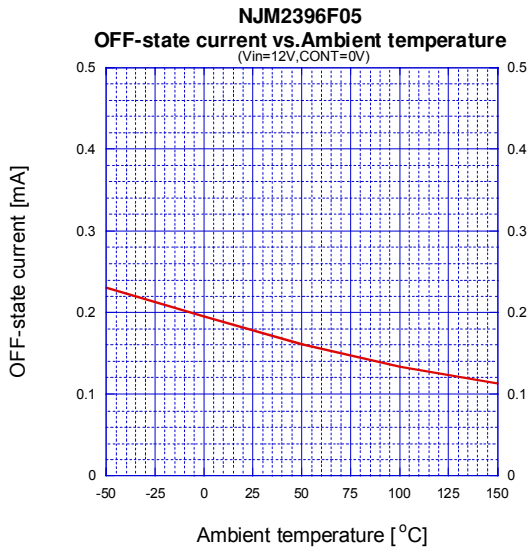
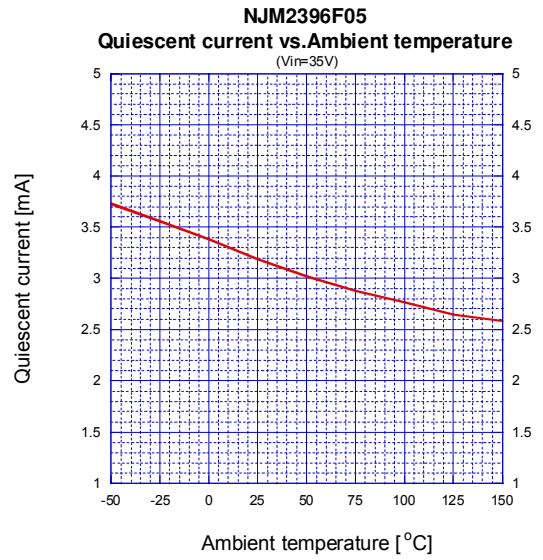
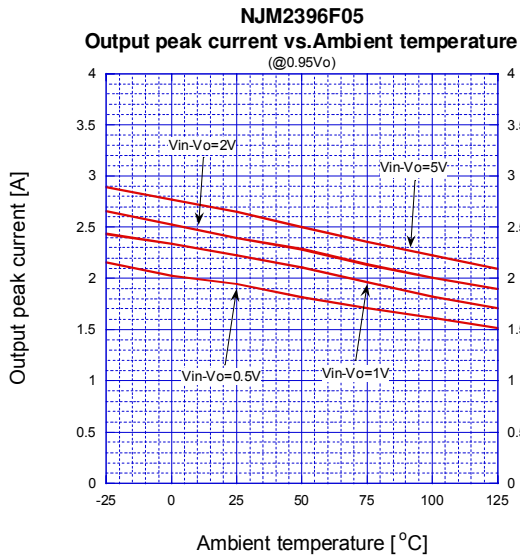

[CAUTION]

The specifications on this databook are only given for information, without any guarantee as regards either mistakes or omissions. The application circuits in this databook are described only to show representative usages of the product and not intended for the guarantee or permission of any right including the industrial rights.