

Negative Output Low Drop Out voltage regulator

■ GENERAL DESCRIPTION

The NJM2827 is a negative output low dropout regulator. Advanced bipolar technology achieves low noise, high precision voltage and high ripple rejection.

It has soft-start and shunt SW function. 1.0 μ F Output capacitor and small package can make NJM2827 suitable for portable items.

■ PACKAGE OUTLINE

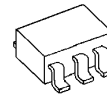

NJM2827F3

■ FEATURES

- Low Dropout Voltage :0.13V (typ.) @ $I_o=60$ mA
- High Precision Output : $\pm 1.5\%$
- High Ripple Rejection :65dB(typ.) @ $f=1$ kHz, $V_o=-7$ V Version
- Output capacitor with 1.0 μ F ceramic capacitor.
- Output Current : $I_o(\text{max.})=100$ mA
- Soft-start Function
- Shunt SW Function
- Internal Thermal Overload Protection
- Internal Short Circuit Current Limit
- Bipolar Technology
- Package Outline SC88A

■ PIN CONFIGURATION

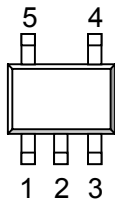

- 1.GND
- 2. V_{IN}
- 3. V_{OUT}
- 4.NC
- 5.CS

NJM2827F3-XX

■ EQUIVALENT CIRCUIT

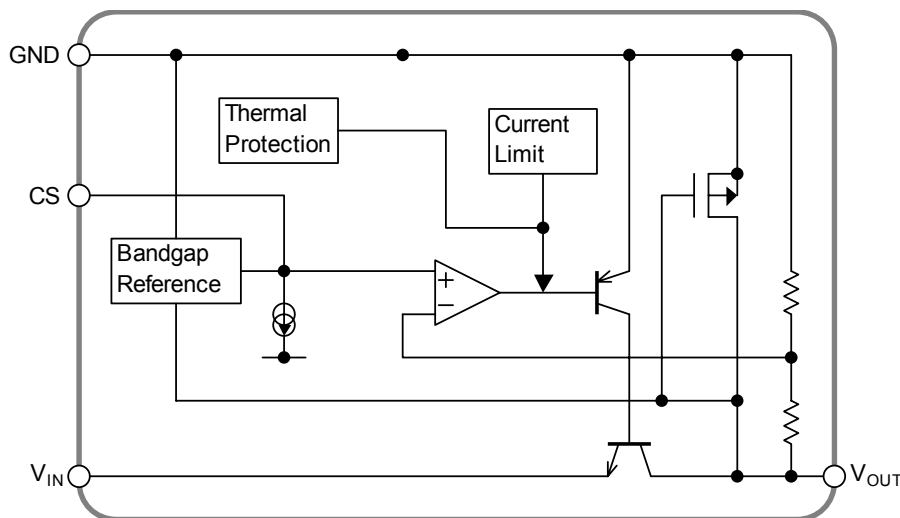

NJM2827

■ OUTPUT VOLTAGE RANK LIST

Device Name	V _{out}
NJM2827F3 -14	-1.4V
NJM2827F3 -15	-1.5V
NJM2827F3 -05	-5.0V
NJM2827F3 -06	-6.0V
NJM2827F3 -07	-7.0V
NJM2827F3 -75	-7.5V
NJM2827F3 -08	-8.0V
NJM2829F3 -10	-10.0V

Output voltage options available: -1.5 ~ -10.0V

■ ABSOLUTE MAXIMUM RATINGS (Ta=25°C)

PARAMETER	SYMBOL	RATINGS	UNIT
Input Voltage	V _{IN}	-14	V
Power Dissipation	P _D	250(*1)	mW
Operating Temperature	T _{opr}	-40 ~ +85	°C
Storage Temperature	T _{stg}	-40 ~ +125	°C

(*1): Mount on EIA/JEDEC STANDARD Test board (76.2*114.3*1.6mm, 2layers, FR-4)

■ Operating voltage

V_{IN}=-3.2 ~ -12V (In case of Vo>-3.0V version)

■ ELECTRICAL CHARACTERISTICS

(Vo<-2.2V Version: V_{IN}=Vo-1V, C_{IN}=0.1μF, Co=1.0μF, Ta=25°C)

(Vo≥-2.2V Version: V_{IN}=-3.2V, C_{IN}=0.1μF, Co=2.2μF (Vo>-2.0V: Co=4.7μF), Ta=25°C)

PARAMETER	SYMBOL	TEST CONDITION	MIN.	TYP.	MAX.	UNIT
Output Voltage	V _o	I _o =30mA	+1.5%	-	-1.5%	V
Quiescent Current	I _Q	I _o =0mA	-	130	200	μA
Output Current	I _o	V _O +0.3V	100	130	-	mA
Line Regulation	ΔV _o /ΔV _{IN}	V _{IN} =V _o -1V ~ -12V (V _O < -2.2V) V _{IN} =-3.2V ~ -12V (V _O ≥ -2.2V) I _o =30mA	-	-	0.10	%/V
Load Regulation	ΔV _o /ΔI _o	I _o =0~60mA	-	-	0.03	%/mA
Dropout Voltage(*2)	ΔV _{I O}	I _o =60mA	-	0.13	0.23	V
Ripple Rejection	RR	V _{IN} =V _o -1V ~ -12V (V _O ≤ -3.0V) V _{IN} =-4.0V ~ -12V (V _O > -3.0V) e _{in} =200mVrms, f=1kHz, I _o =10mA, V _o =-7V Version	-	65	-	dB
Average Temperature Coefficient of Output Voltage	ΔV _o /ΔTa	Ta=0 ~ 85°C, I _o =10mA	-	±50	-	ppm/°C
Output Noise Voltage	V _{NO}	f=10Hz~80kHz, I _o =10mA, V _o =-7V Version	-	100	-	μVrms
CS Terminal Charge Current	I _{CS}	V _{CS} =0V	4	5	6	μA
Input Voltage	V _{IN}		-12	-	-	V

(*2): Excludes Vo>-3.0V version.

The above specification is a common specification for all output voltages.

Therefore, it may be different from the individual specification for a specific output voltage.

■ TEST CIRCUIT

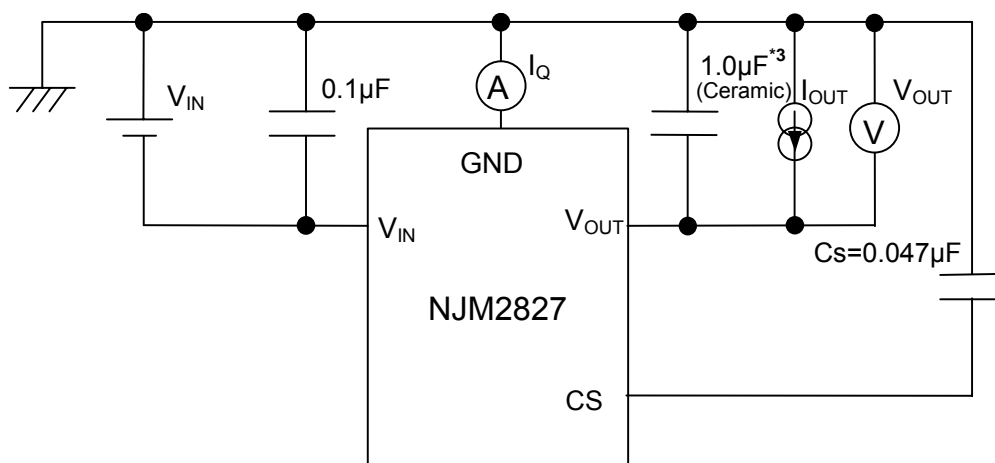

*3 $-2.2V \leq V_o \leq -2.0V$ version: $C_o = 2.2\mu F$ (Ceramic)
 $V_o > -2.0V$ version: $C_o = 4.7\mu F$ (Ceramic)

NJM2827

■ TYPICAL APPLICATIONS

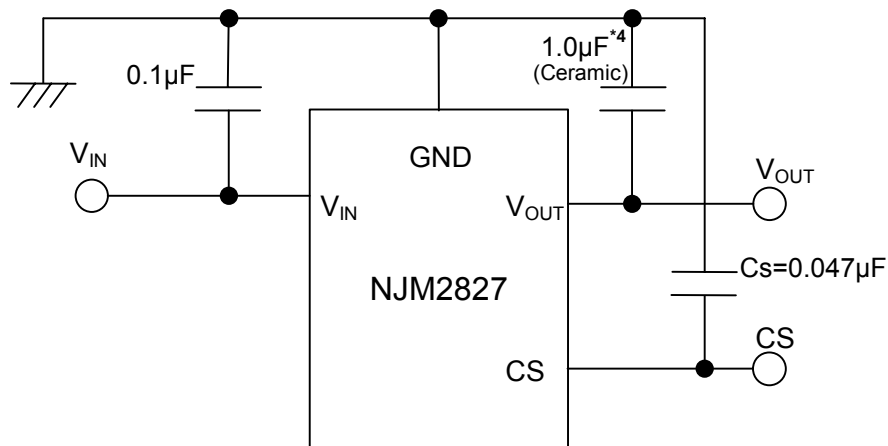

*4 -2.2V ≤ V_O ≤ -2.0V version: C_O = 2.2µF (Ceramic)
V_O > -2.0V version: C_O = 4.7µF (Ceramic)

*Input Capacitance C_{IN}

Input capacitance C_{IN} is required to prevent oscillation and reduce power supply ripple for applications with high power supply impedance or a long power supply line.

Use the C_{IN} value of 0.1µF greater to avoid the problem.

C_{IN} should connect between GND and V_{IN} as short as possible.

*Output Capacitance C_O

Output capacitor (C_O) is required for a phase compensation of the internal error amplifier. The capacitance and the equivalent series resistance (ESR) influences stability of the regulator.

This product is designed to work with a low ESR capacitor for the C_O; however, use of recommended capacitance or greater value is essential for stable operation.

Use of a smaller C_O may cause excess output noise or oscillation of the regulator due to lack of the phase compensation.

Therefore, use C_O with the recommended capacitance or greater value and connect between V_O terminal and GND terminal with minimal wiring. The recommended capacitance depends on the output voltage. Low voltage regulator requires greater value of the C_O. Thus, check the recommended capacitance for each output voltage.

Use of a greater C_O reduces output noise and ripple output, and also improves transient response of the output voltage against rapid load change.

*Soft-start function

Capacitance C_s connect between CS pin and GND for the following.

- Control at risetime of output voltage.
- Reduces inrush current at output ON.

When the soft start function is not used, CS pin should be open.

1.Cs capacitance vs risetime of output voltage

Calculation : risetime of output voltage $\Delta t \cong 213 \times C_s(\mu\text{F})$

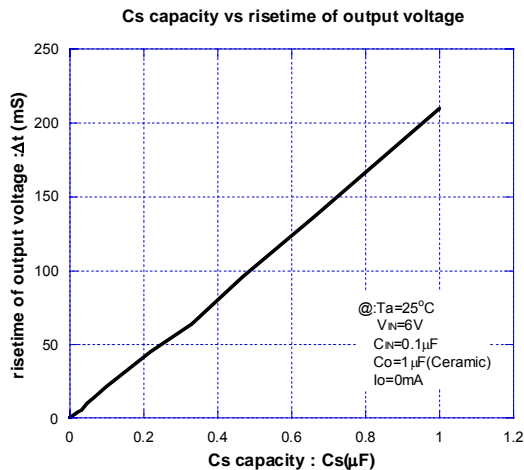

2.Inrush current at control ON

The peak value of the inrush current can be limited according to the capacitance of the C_s .

Inrush current wave :

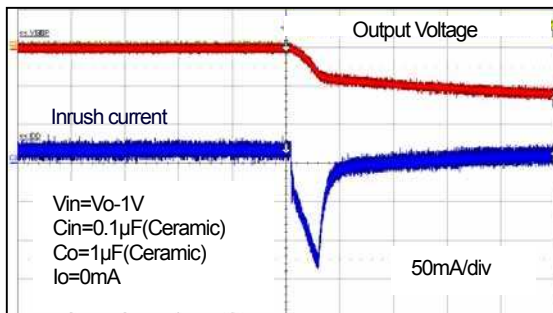

Inrush Peak Current=150mA(Cs=Open)

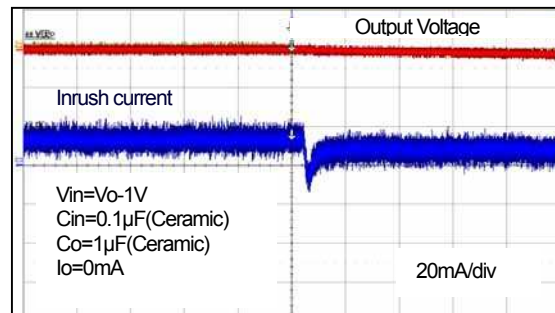

Inrush Peak Current=20mA(Cs=0.0047μF)

* This characteristic is one example. It is necessary to examine the characteristic with an actual circuit because there is an influence by the characteristic such as output voltage/output capacitor.

■ POWER DISSIPATION vs. AMBIENT TEMPERATURE

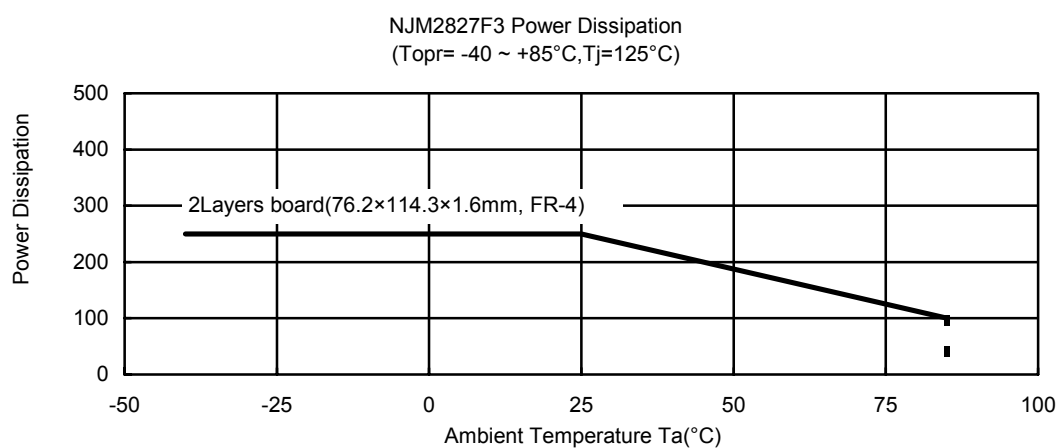

TYPICAL CHARACTERISTICS

