

## LOW DROPOUT VOLTAGE REGULATOR

### ■ GENERAL DESCRIPTION

The NJU7780/81 is a low dropout voltage regulator with ON/OFF Control.

Advanced CMOS technology achieves low quiescent current. It is suitable for battery operating applications.

NJU7781 features shunt switch which improves turn off response of output voltage when ON/OFF control is used.

### ■ PACKAGE OUTLINE

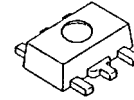

NJU7780/81U1

### ■ FEATURES

- High Ripple Rejection      65dB typ. (f=400Hz, Vo=3V)
- Low quiescent Current      Iq=20μA (Io=0mA, V<sub>CONT</sub>=V<sub>IN</sub>)
- Output capacitor with 1.0μF ceramic capacitor
- Output Current              Io(max)=300mA
- High Precision Output      Vo±1.0%
- Low Dropout Voltage        0.15V typ. (Io=150mA, Vo=3.0V)
- ON/OFF Control              (Active High)
- Shunt Switch                 Only NJU7781
- Internal Over Current Protection
- Internal Thermal Overload Protection
- CMOS technology
- Package outline              SOT-89-5

### ■ PIN CONFIGURATION

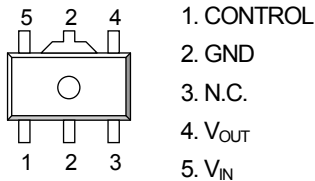

### ■ EQUIVALENT CIRCUIT

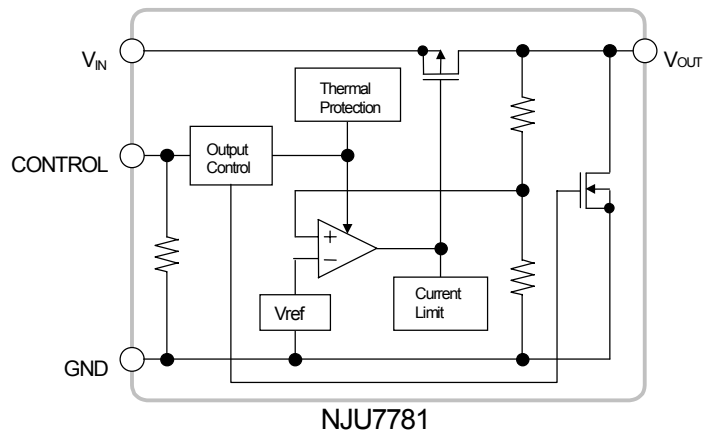
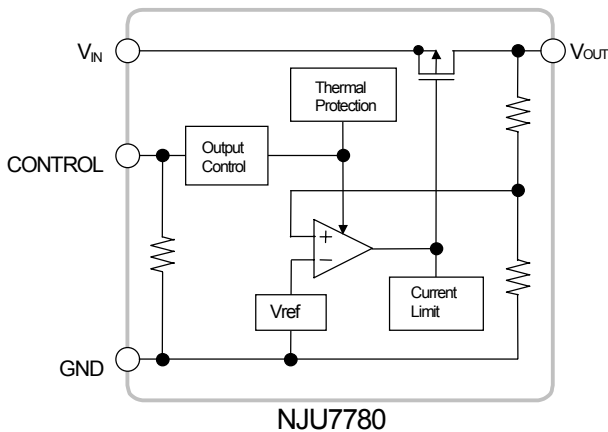

# NJU7780/81

## ■ OUTPUT VOLTAGE RANK LIST (1.5V~5.0V : 0.1V step)

Device Name	V <sub>OUT</sub>	Device Name	V <sub>OUT</sub>	Device Name	V <sub>OUT</sub>
NJU778xU1-15	1.5V	NJU778xU1-28	2.8V	NJU778xU1-04	4.0V
NJU778xU1-18	1.8V	NJU778xU1-29	2.9V	NJU778xU1-05	5.0V
NJU778xU1-21	2.1V	NJU778xU1-03	3.0V		
NJU778xU1-25	2.5V	NJU778xU1-33	3.3V		

## ■ ABSOLUTE MAXIMUM RATINGS

(Ta=25°C)

PARAMETER	SYMBOL	RATINGS	UNIT
Input Voltage	V <sub>IN</sub>	+10	V
Control Voltage	V <sub>CONT</sub>	+10(*1)	V
Power Dissipation	P <sub>D</sub>	350(*2)	mW
Operating Temperature	T <sub>opr</sub>	-40 ~ +85	°C
Storage Temperature	T <sub>stg</sub>	-40 ~ +125	°C
OFF-state Output Sink Current (*3)	I <sub>o</sub>	10	mA

(\*1): When input voltage is less than +10V, the absolute maximum control voltage is equal to the input voltage.

(\*2): Device itself.

(\*3): This maximum rating is applied to NJU7781.

## ■ Operating voltage

V<sub>IN</sub>=+2.3 ~ +9V (In case of V<sub>o</sub><2.1V version)

## ■ ELECTRICAL CHARACTERISTICS

(V<sub>IN</sub>=V<sub>o</sub>+1V, C<sub>IN</sub>=0.1μF, C<sub>o</sub>=0.1μF, Ta=25°C)

PARAMETER	SYMBOL	TEST CONDITION	MIN.	TYP.	MAX.	UNIT	
Output Voltage	V <sub>o</sub>	I <sub>o</sub> =30mA	-1.0%	-	+1.0%	V	
Input Voltage	V <sub>IN</sub>		-	-	9	V	
Quiescent Current	I <sub>Q</sub>	I <sub>o</sub> =0mA, V <sub>CONT</sub> =V <sub>IN</sub>	-	20	40	μA	
Quiescent Current at Control OFF	I <sub>Q(OFF)</sub>	V <sub>CONT</sub> =0V	-	-	1	μA	
Output Current	I <sub>o</sub>	V <sub>o</sub> - 0.1V(V <sub>o</sub> <2.1V) V <sub>o</sub> - 0.3V(V <sub>o</sub> ≥2.1V)	300	-	-	mA	
Short Current Limit	I <sub>LIM</sub>	V <sub>o</sub> =0V	-	120	-	mA	
Line Regulation	ΔV <sub>o</sub> /ΔV <sub>IN</sub>	V <sub>IN</sub> =V <sub>o</sub> +1V~V <sub>o</sub> +6V(V <sub>o</sub> <3.0), V <sub>IN</sub> =V <sub>o</sub> +1V~V <sub>o</sub> +9V(V <sub>o</sub> ≥3.0), I <sub>o</sub> =30mA	-	-	0.10	%/V	
Load Regulation	ΔV <sub>o</sub> /ΔI <sub>o</sub>	I <sub>o</sub> =0~300mA	-	-	0.015	%/mA	
Dropout Voltage(*4)	ΔV <sub>I-O</sub>	I <sub>o</sub> =150mA	2.1 ≤ V <sub>o</sub> ≤ 2.6V	-	0.18	0.25	V
			2.7 ≤ V <sub>o</sub> ≤ 3.3V	-	0.15	0.22	
			3.4 ≤ V <sub>o</sub> ≤ 5.0V	-	0.12	0.2	
Ripple Rejection	RR	e <sub>in</sub> =200mVrms, f=400Hz, I <sub>o</sub> =10mA, V <sub>o</sub> =3.0V	-	65	-	dB	
Average Temperature Coefficient of Output Voltage	ΔV <sub>o</sub> /ΔTa	Ta=0~85°C, I <sub>o</sub> =10mA	-	±100	-	ppm/ <sup>o</sup> C	
Output Noise Voltage	V <sub>NO</sub>	F=10Hz~80kHz, I <sub>o</sub> =10mA, V <sub>o</sub> =3.0V	-	80	-	μVrms	
Pull-Down Resistance	R <sub>CONT</sub>		1.5	5	10	MΩ	
Control Voltage for ON-state	V <sub>CONT(ON)</sub>		1.6	-	-	V	
Control Voltage for OFF-state	V <sub>CONT(OFF)</sub>		-	-	0.3	V	
Pull-down Resistance at OFF-state(*5)	R <sub>O(OFF)</sub>	V <sub>CONT</sub> =0V (V <sub>o</sub> =3.0V Version)	-	190	-	Ω	

(\*4): The output voltage excludes under 2.1V.

(\*5) This electrical characteristics is applied to NJU7781.

The above specification is a common specification for all output voltages.

Therefore, it may be different from the individual specification for a specific output voltage.

## ■ TEST CIRCUIT

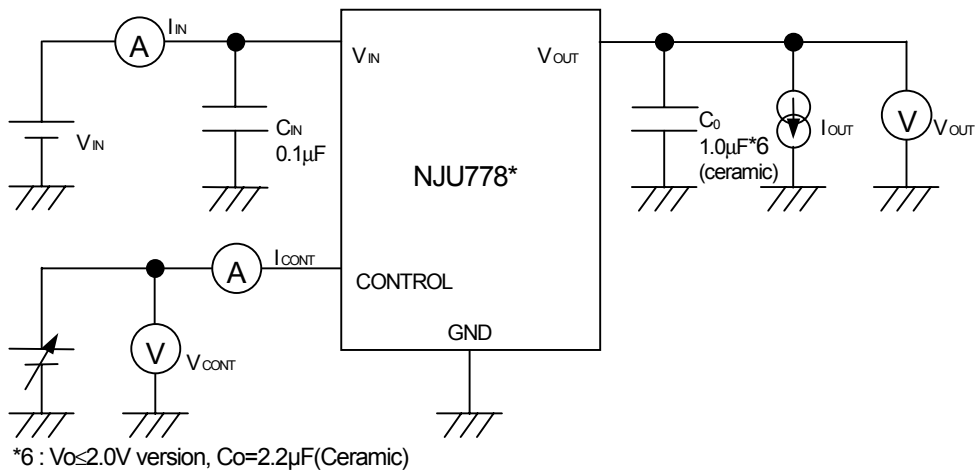

## ■ TYPICAL APPLICATION

① In the case where ON/OFF Control is not required:

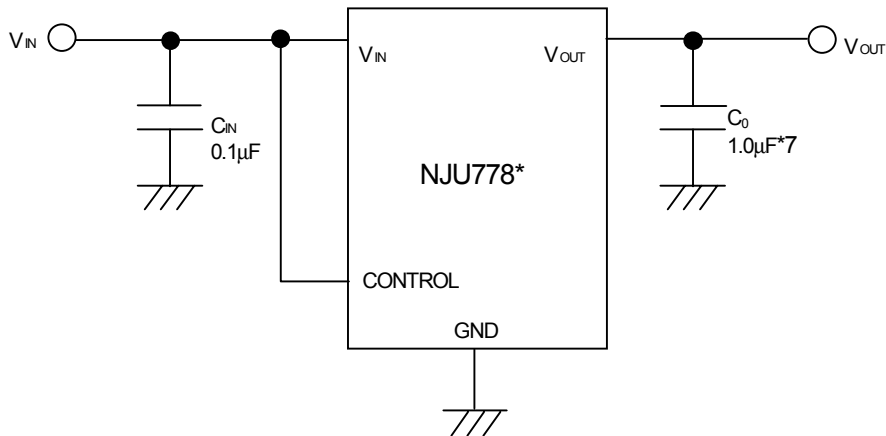

\*7:  $V_O \leq 2.0V$  version,  $C_O = 2.2\mu F$

Connect control terminal to  $V_{IN}$  terminal

② In use of ON/OFF CONTROL:

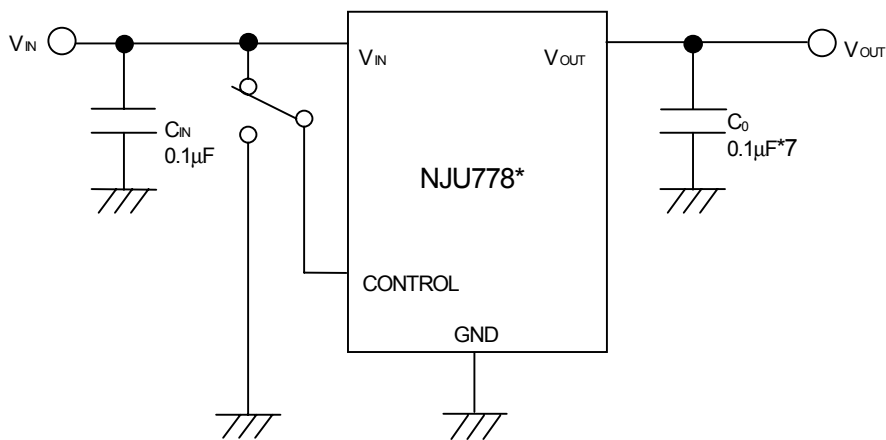

\*7:  $V_O \leq 2.0V$  version,  $C_O = 2.2\mu F$

State of control terminal:

- “H” → output is enabled.
- “L” or “open” → output is disabled.

# NJU7780/81

## ELECTRICAL CHARACTERISTICS

### DC CHARACTERISTICS

