

ADJUSTABLE HIGH PRECISION SHUNT REGULATOR

■GENERAL DESCRIPTION

The **NJM2820/ 2821/ 2822** is a 1.25V precision shunt regulator.

High precision voltage accuracy of $\pm 0.7\%$ * is realized by the total optimization from chip design to packaging. In addition, it features low cathode current of 80uA for low current operation.

It is suitable for AC-DC converter secondary circuit, reference voltage applications for A/D and D/A converters, and other applications where precision reference is required.

■FEATURES

- High Precision Voltage Reference 1.25V \pm 0.7%
- Flow Soldering*
- Minimum Input Current 80uA typ.
- Operating Voltage V_{REF} to 13V
- Adjustable Output Voltage
- Bipolar Technology
- Package Outline MTP5

■BLOCK DIAGRAM

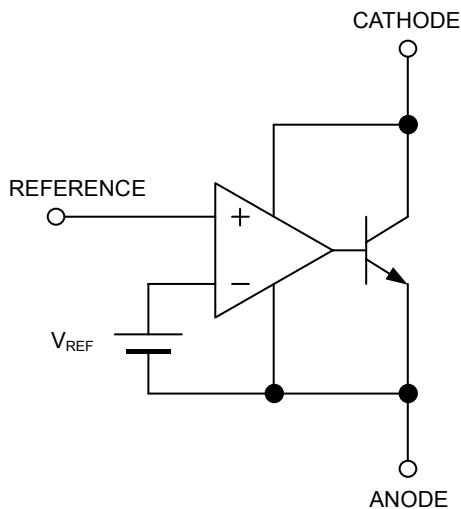

■PACKAGE OUTLINE

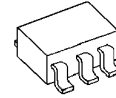

NJM2820F
NJM2821F
NJM2822F

■PIN CONFIGURATION

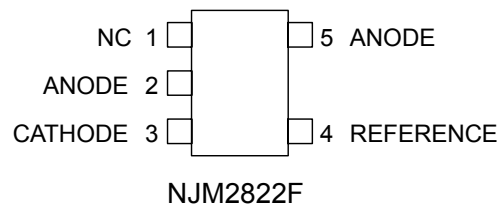
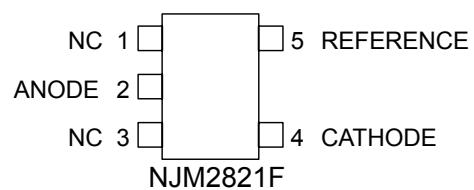
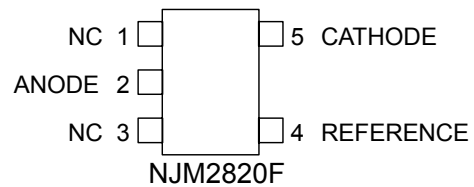

* These contents are based on the result that evaluated the arbitrary sample. The characteristic is not guaranteed. The design and reliability that fully considered flow mounting are checked but the influence by temperature profile etc. is also considered. Please consult with sales representatives for a recommendation temperature profile.

NJM2820, NJM2821, NJM2822

■ABSOLUTE MAXIMUM RATINGS (Ta=25°C)

| PARAMETER | SYMBOL | MAXIMUM RATINGS | UNIT |
|-----------------------------|-----------|-----------------|------|
| Cathode Voltage | V_{KA} | 14 | V |
| Continuous Cathode Current | I_K | -30 ~ 50 | mA |
| Reference Input Current | I_{REF} | -10 ~ 0.05 | mA |
| Power Dissipation | P_D | (MTP5) 200 | mW |
| Operating Temperature Range | T_{OPR} | -40 ~ +85 | °C |
| Storage Temperature Range | T_{STG} | -40 ~ +150 | °C |

■RECOMMENDED OPERATING CONDITIONS (Ta=25°C)

| PARAMETER | SYMBOL | MIN. | TYP. | MAX. | UNIT |
|-----------------|----------|-----------|------|------|------|
| Cathode Voltage | V_{KA} | V_{REF} | - | 13 | V |
| Cathode Current | I_K | 0.5 | - | 30 | mA |

■ELECTRICAL CHARACTERISTICS ($I_K=1mA, Ta=25°C$)

| PARAMETER | SYMBOL | TEST CONDITION | MIN. | TYP. | MAX. | UNIT |
|---|--------------------------------|--|------|------|-----------|----------|
| Reference Voltage | V_{REF} | $V_{KA}=V_{REF}$ (*1) | 1241 | 1250 | 1259 | mV |
| Reference Voltage Change vs. Cathode Voltage Change | $\Delta V_{REF}/\Delta V_{KA}$ | $ V_{REF} \leq V_{KA} \leq 5V$ (*2) | - | - | ± 2.7 | mV/V |
| | | $5V \leq V_{KA} \leq 13V$ (*2) | - | - | ± 2.0 | mV/V |
| Reference Input Current | I_{REF} | $R1=10k\Omega, R2=\infty$ (*2) | - | 2.0 | 4.0 | μA |
| Minimum Input Current | I_{MIN} | $V_{KA}=V_{REF}, \Delta V_{REF}=1\%$ (*1) | - | 80 | 500 | μA |
| Cathode Current (Off Cond.) | I_{OFF} | $V_{KA}=13V, V_{REF}=0V$ (*3) | - | 0.01 | 1.0 | μA |
| Dynamic Impedance | $ Z_{KA} $ | $V_{KA}=V_{REF}, f \leq 1kHz$ $0.5mA \leq I_K \leq 30mA$ (*1) | - | 0.12 | - | Ω |

■TEMPERATURE CHARACTERISTICS ($I_K=1mA, Ta=-40°C \sim 85°C$)

| PARAMETER | SYMBOL | TEST CONDITION | MIN. | TYP. | MAX. | UNIT |
|--------------------------------|------------------|--------------------------------|------|----------|------|---------|
| Reference Voltage Change | ΔV_{REF} | $V_{KA}=V_{REF}$ (*1) | - | ± 10 | - | mV |
| Reference Input Current Change | ΔI_{REF} | $R1=10k\Omega, R2=\infty$ (*2) | - | 0.5 | - | μA |

$|V_{REF}|$...Reference voltage includes error.

(*1): Test Circuit (Fig.1)

(*2): Test Circuit (Fig.2)

(*3): Test Circuit (Fig.3)

In case of NJM2822, all electrical characteristics are measured referencing to the anode terminal of PIN 5.

■TEST CIRCUIT

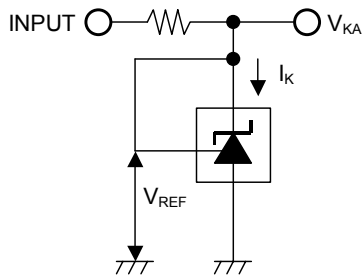

Fig.1 $V_{KA} = V_{REF}$ to test circuit

$$V_O = V_{KA} = V_{REF}$$

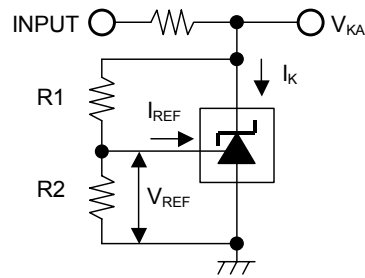

Fig.2 $V_{KA} > V_{REF}$ to test circuit

$$V_O = V_{KA} = V_{REF} \left(1 + \frac{R1}{R2} \right) + I_{REF} \times R1$$

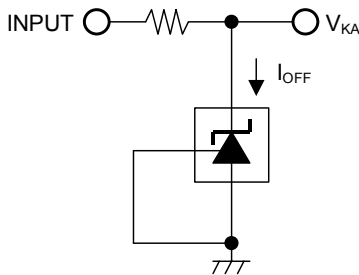

Fig.3 I_{OFF} to test circuit

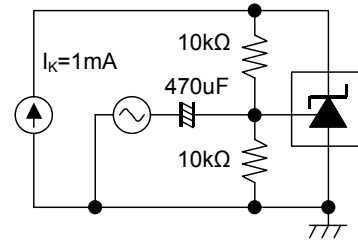

Fig.4 Gain and Phase to test circuit

■POWER DISSIPATION VS. AMBIENT TEMPERATURE

