

455kHz INPUT FM IF DEMODULATOR

■ GENERAL DESCRIPTION

The **NJM2590** and **NJM2597** are low current FM IF demodulator ICs with 455kHz IF input, which operate from 1.6V supply.

The **NJM2590/97** contain the minimum functions required to FM IF demodulator, that is, IF amplifier, quadrature detector, LPF amplifier, FSK comparator, RSSI, and RSSI comparator. It offers unmatched design flexibility.

■ PACKAGE OUTLINE

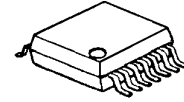

NJM2590V/97V

■ FEATURES

- Low Operating Voltage 1.6V to 5.5V
- Low Operating Current 550uA at $V^+ = 1.8V$
- IF Input Frequency 455kHz (standard)
- RSSI Comparator
- The Range of Linear Area on RSSI Output versus IF Input Characteristics

NJN2590	IF Input level=25 to 60 dBuVEMF (reference value)
NJM2597	IF Input level=35 to 85 dBuVEMF (reference value)
- Bipolar Technology
- Package Outline SSOP14

■ BLOCK DIAGRAM

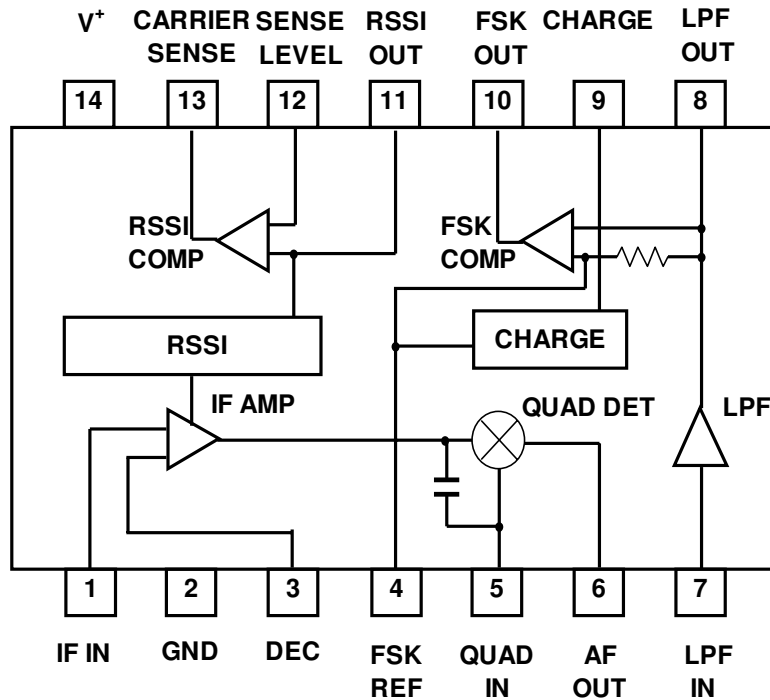

NJM2590/97

■ ABSOLUTE MAXIMUM RATINGS

(Ta=25°C)

PARAMETER	SYMBOL	RATINGS	UNIT
Supply Voltage	V ⁺	8.0	V
Power Dissipation	P _D	300	mW
Operating Temperature	T _{opr}	- 40 to +85	°C
Storage Temperature	T _{stg}	- 40 to +125	°C

■ RECOMMENDED OPERATIONAL CONDITION

(Ta=25°C)

PARAMETER	SYMBOL	TEST CONDITIONS	MIN.	TYP.	MAX.	UNIT
Supply Voltage	V ⁺		1.6	1.8	5.5	V

■ ELECTRICAL CHARACTERISTICS (Ta=25°C, V⁺=1.8V, fin=455kHz, fmod=600Hz, fdev=±4kHz)

PARAMETER	SYMBOL	TEST CONDITIONS	MIN.	TYP.	MAX.	UNIT	
Current Consumption	I _{ccq}	No Signal	440	550	660	uA	
IF Amplifier Input Resistance	R _{in}		(1.6)	2	(2.4)	kΩ	
Signal to Noise Ratio 1	S/N1	Vi=60dBu EMF	-	60	-	dB	
Signal to Noise Ratio 2	S/N2	Vi=25dBu EMF	-	30	-	dB	
- 3dB Limiting Sensitivity	V _{in(lim)}		-	22	27	dBu EMF	
Demodulated Output Level	V _{od}	Vi=60dBu EMF	35	40	65	mVrms	
AM Rejection Ratio	AMR	Vi=60dBu EMF AM=30%	-	50	-	dB	
Duty Ratio of Wave Shaped Output	DR	Vi=60dBu EMF	40	50	60	%	
Quick Charge/Discharge Current	I _{ch}	V _{FSK OUT} =GND V _{LPF OUT} =0.18V	35	65	110	uA	
RSSI Output Voltage	NJM2590	V _{rssi}	Vi=40dBu EMF	0.7	0.9	1.1	V
	NJM2597		Vi=80dBu EMF	0.8	1.1	1.4	
High Level Leak Current of FSK OUT Terminal	I _{fskH}	V _{FSK OUT} =V ⁺	(-0.1)	(0)	(0.1)	uA	
Low Level Voltage of FSK OUT Terminal	V _{fskL}	I _{FSK OUT} =100uA	-	0.1	0.4	V	
High Level Leak Current of CARRIER SENSE Terminal	I _{cryH}	V _{CARRIER SENSE} =V ⁺	(-0.1)	(0)	(0.1)	uA	
Low Level Voltage of CARRIER SENSE Terminal	V _{cryL}	I _{CARRIER SENSE} =100uA	0.0	0.1	0.4	V	
Bias Current of SENSE LEVEL Terminal	I _{level}	V _{CARRIER SENSE} =0.8V	(-1.0)	(0)	(1.0)	uA	

The value shown in parenthesis are reference values.

■ TEST CIRCUIT

This test circuit allows the measurement of all parameters described in "ELECTRICAL CHARACTERISTICS". This test circuit includes some electrical switches that should be in the suitable positions for the measurement of each parameter. For the best measurement of each parameter, the drawings of "Test Circuit 1 to 10" are additionally prepared to show the switching positions and other changes of connection. Note that "Test Circuit 1 to 10" are not the complete circuit to measure.

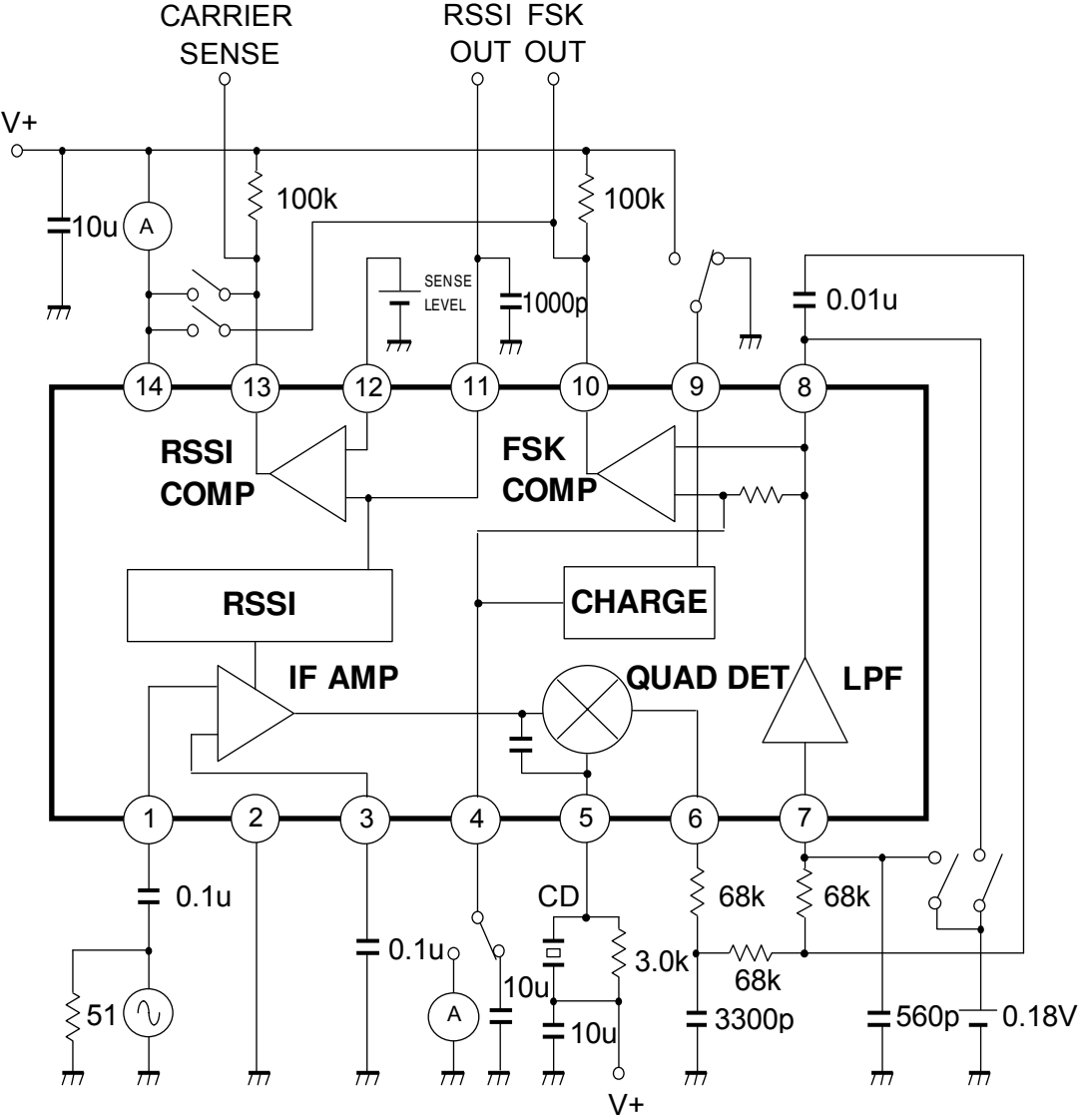

Note :

1. "CD" means a ceramic discriminator of 455kHz ; CDBC455KCAY66-R0(MURATA,JAPAN)

Test Circuit 1

S/N1, S/N2, Vin(lim), Vod, AMR

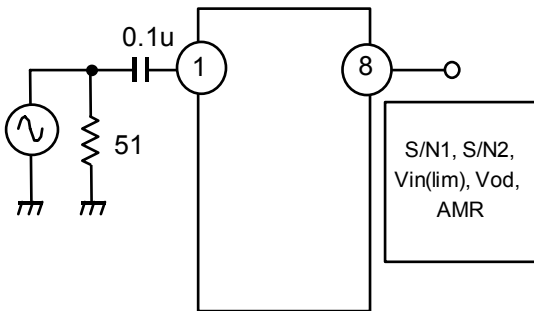

Test Circuit 2

DR

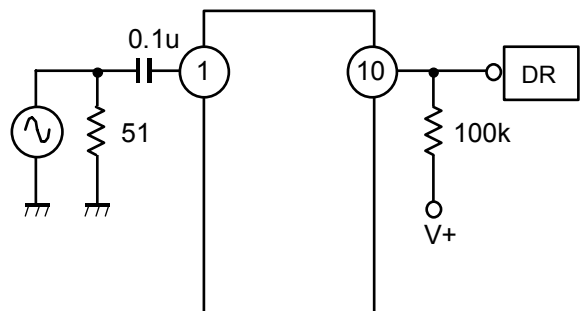

Test Circuit 3

Iccq

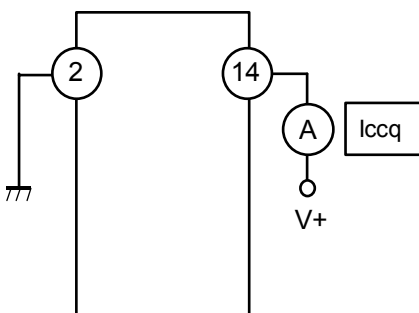

Test Circuit 4

Vrssi

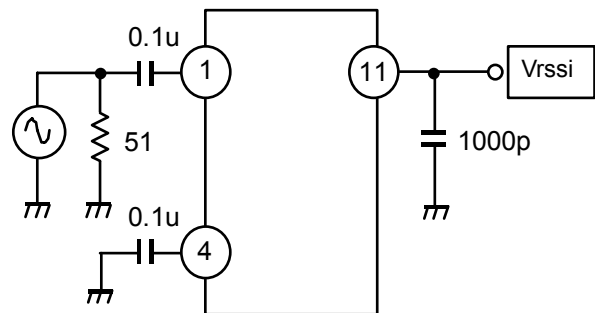

Test Circuit 5

Ich

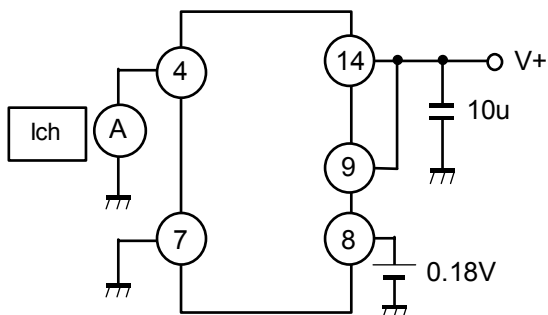

Test Circuit 6

VfskL

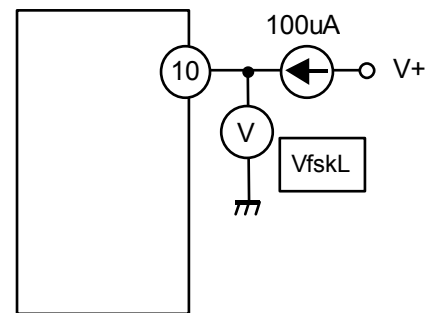

Test Circuit 7
IfskH

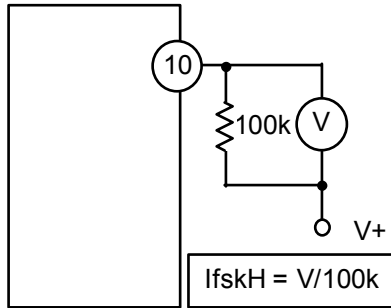

Test Circuit 8
IcryH

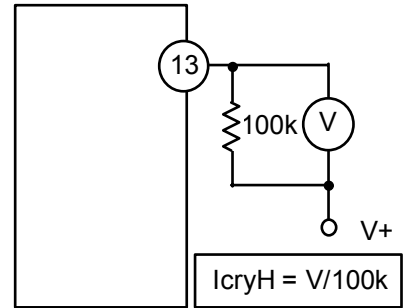

Test Circuit 9
VcryL

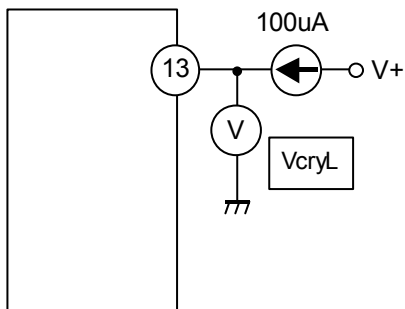

Test Circuit 10
Ilevel

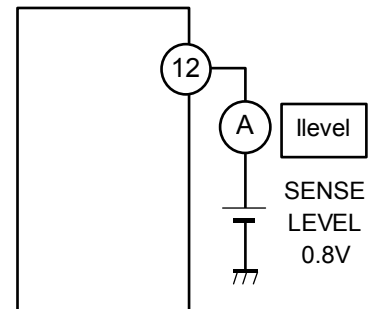

NJM2590/97

■ EVALUATION BOARD

For obtaining actual performance data, an evaluation board is available. Note that this board is not prepared for the reference design of parts layout, pattern layout and so on.

● Circuit Diagram

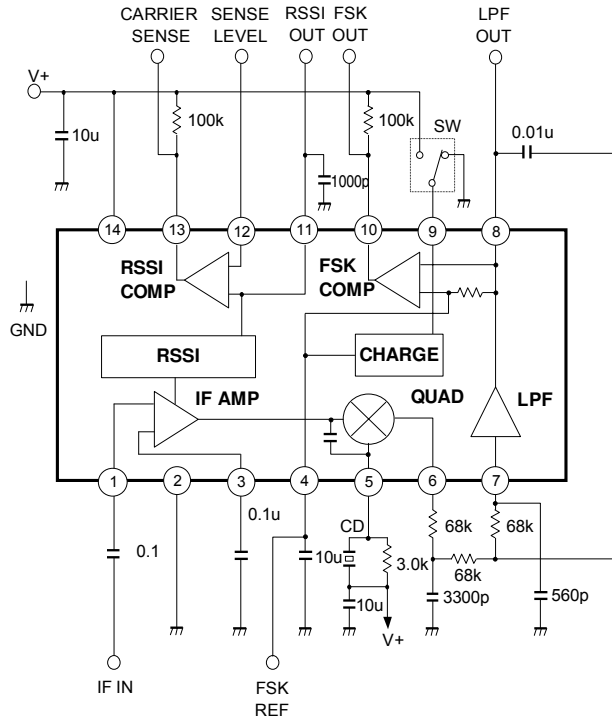

CD: Ceramic discriminator, CDBC455KCAY66-R0 (Murata manufacturing Co., Ltd.)

● Circuit Board

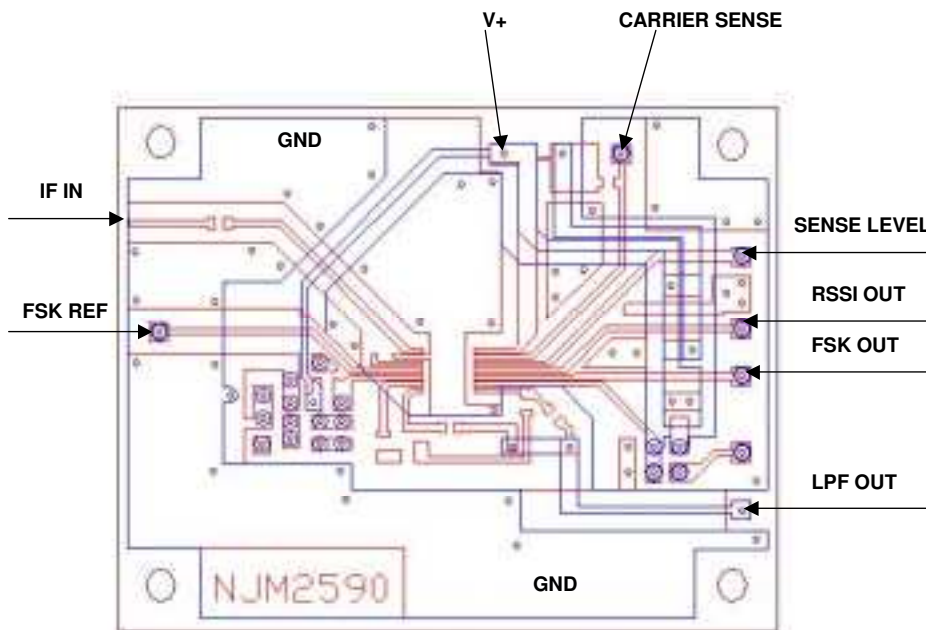

■ **TERMINAL FUNCTION** (Ta=25°C, V+=1.8V)

Pin No.	SYMBOL	EQUIVALENT CIRCUIT	VOLTAGE	FUNCTION
1	IF IN		1.75V	IF Amplifier Input. Typical input impedance is 2kΩ. Built-in ESD protective circuit.
3	DEC		1.75V	IF Decoupling. Connected with an external decoupling capacitor. Built-in ESD protective circuit
2	GND		--	Ground.
4	FSK REF		0.9V	FSK Reference Input. This is a reference input of wave shaping comparator. Connected with an external capacitor. A quick charge/discharge circuit offers the voltage of pin 4 comes the same voltage of pin 8 quickly. Built-in ESD protective circuit.
5	QUAD IN		0.5V	Quadrature Detector Input. Connected with a ceramic discriminator. Built-in ESD protective circuit.
6	AF OUT		0.2V	FM demodulated signal output. Built-in ESD protective circuit.

NJM2590/97

Pin No.	SYMBOL	EQUIVARENT CIRCUIT	VOLTAGE	FUNCTION
7	LPF IN		0.18V	Low Pass Filter Input. This terminal is biased from the pin 6 through an external RC filter. Built-in ESD protective circuit.
8	LPF OUT		0.18V	Low Pass Filter Output. Built-in ESD protective circuit.
9	CHARGE		-	Quick Charge/Discharge Control. The power supply output voltage to pin 9 sets up the quick charge / discharge circuit. Instead of the power supply, another power source can also be used within the limit of the rated supply voltage. Built-in ESD protective circuit between pin 9 and ground.
10	FSK OUT		-	FSK Output. FSK comparator is a wave shaping circuit. A LPF output signal is inverted and wave-shaped. Instead of the power supply, another power source can also be used within the limit of the rated supply voltage. Built-in ESD protective circuit between pin 10 and ground.
11	RSSI OUT		50mV	Received Signal Strength Indicator Output. Pin 11 outputs DC level proportional to the log of input signal level to pin 1. Built-in ESD protective circuit.

Pin No.	SYMBOL	EQUIVALENT CIRCUIT	VOLTAGE	FUNCTION
12	SENSE LEVEL		-	Sense Level Input. Built-in ESD protective circuit.
13	CARRIER SENSE		-	Carrier Sense Output. The result of RSSI comparator is output by comparing RSSI output level with an external input level to pin 12. Built-in ESD protective circuit between pin 13 and ground.
14	V+		-	Power Supply.

DESCRIPTION

1. FSK comparator (FSK COMP)

FSK comparator is a wave shaping circuit. When the demodulated FSK signal is weak or noisy, the computer may fail to read this signal. To prevent the read-error, the wave shaping circuit will change this weak or noisy signal to the correct signal. Pin 10 usually pulls up to power supply output voltage through an external high-valued resistor. This external resistor can be connected to another power source within the limit of absolute maximum ratings.

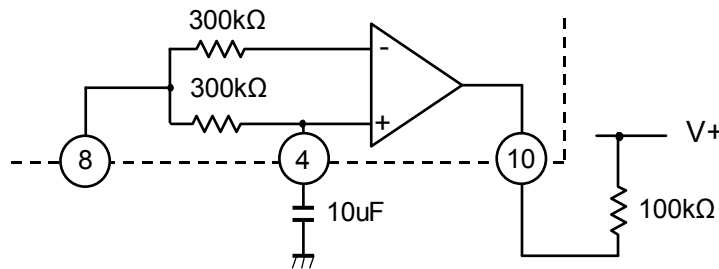

2. Quick charge/ discharge circuit

The DC voltage of pin 4 is ordinarily equal to that of the demodulated FSK signal. When the initial state of power-up turns into a steady state, the voltage of pin 4 will be late to come up to the reference voltage by reason of time constant of an external capacitor and an internal resistor. At that time the wave shaped data may be failed to read correctly. The quick charge/discharge circuit serves a useful function to shorten the rise time when power is turned on. When power supply is hooked up to pin9 upon turning the power on, this circuit will charge/discharge the external capacitor quickly to prevent read-error. Instead of the power supply, another power source can also be used within the limit of the rated supply voltage.

During the high-speed charge/discharge circuit runs, DC level of FM demodulated signal may varies with frequency shift or others. Even in such a case, the voltage of pin 4 follows the voltage of FM demodulated signal so that the duty ratio of wave shaped output can keep constant.

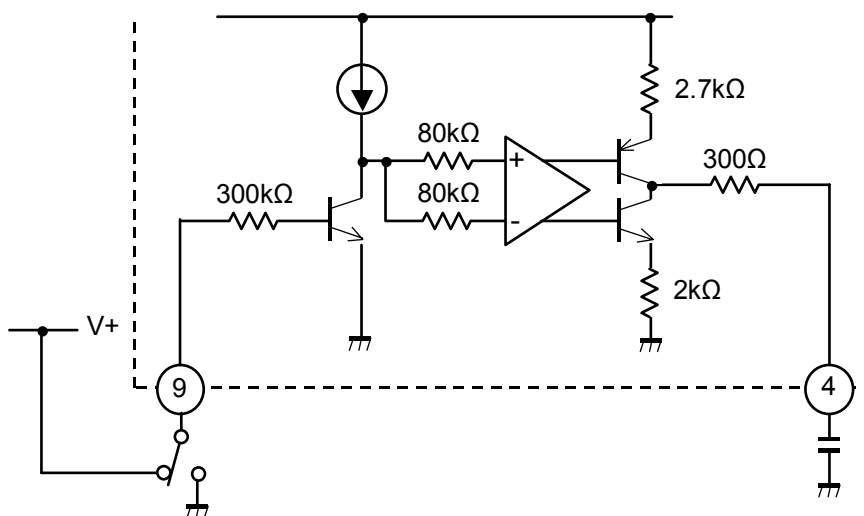

3. Carrier sense

The result of comparator is output to pin13 by comparing the output voltage of pin11 with external reference voltage of pin 12. Because pin13 is an open-collector terminal, an external resistor can be connected to another power supply within the limit of absolute maximum ratings.

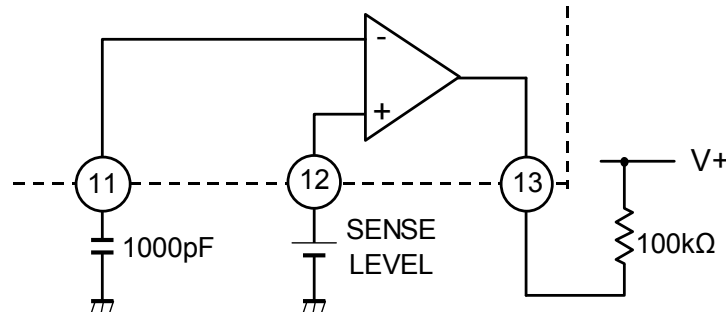

4. RSSI circuit (RSSI)

A DC voltage corresponding to the input level of pin1 is output to pin11. The internal resistance of pin11 is around 48 kΩ. The RSSI characteristics can be changed by adding an external resistor,. In such a case, note that the temperature characteristics of pin 11 may alter due to a disparity between the temperature coefficient of the external resistor and the internal resistor of pin 11.

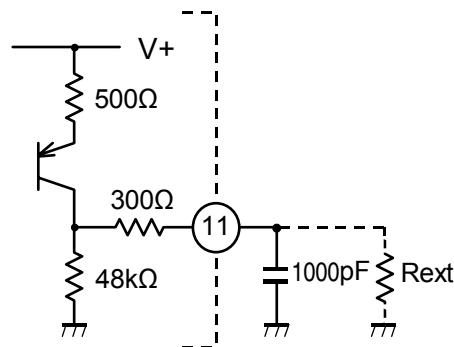

5. Low pass filter (LPF)

This is a 3rd-order multiple feedback filter.
The cut-off frequency F_c is obtained by ;

$$F_c = \frac{1}{2\pi \sqrt[3]{R_a R_b R_c C_a C_b C_c}} [Hz] \quad \text{where } R_a=R_b=R_c \text{ or } C_a=C_b=C_c$$

Each of pin7(LPF IN) and pin8(LPF OUT) has a built-in ESD protective resistor 300Ω.

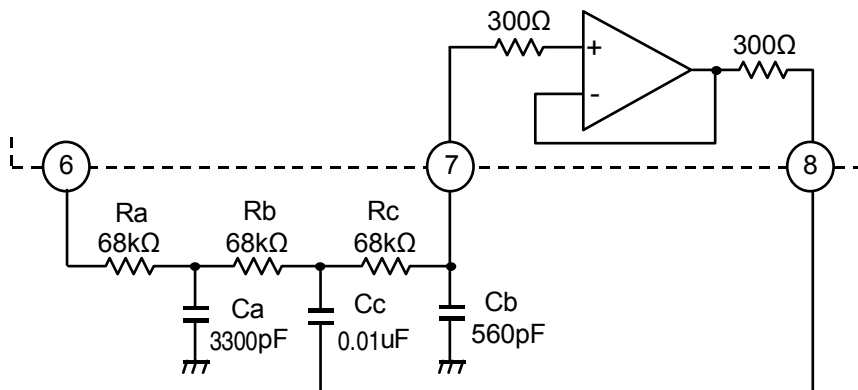

■ APPLICATION CIRCUIT

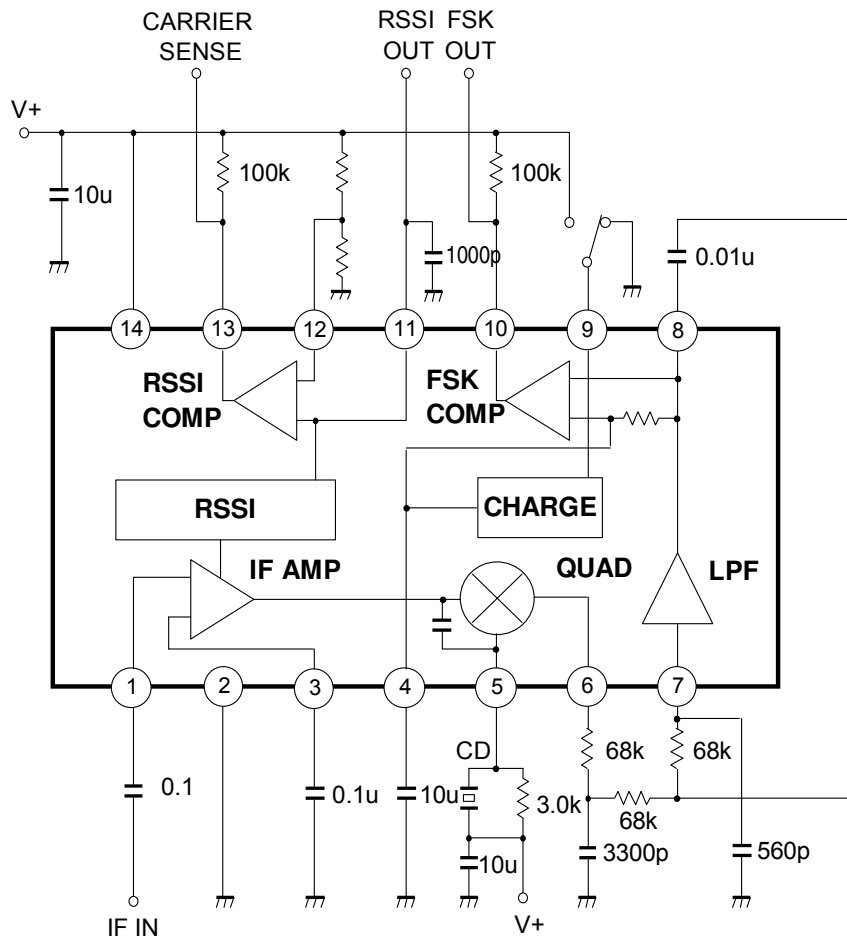

The NJM2590 itself works with the operational temperature from -40 to +85°C. However this matter is not meant to insure the reliability of this application circuit under the temperature from -40 to +85°C.

■ CERAMIC DISCRIMINATOR (especially designed for NJM2590/97)

To optimize some important performance, the following ceramic discriminator is available. For more information on this CD and 450kHz CD, please contact the CD supplier.

CDBC455KCAY66-R0 (Murata Manufacturing Co., Ltd., JAPAN)

TYPICAL CHARACTERISTICS

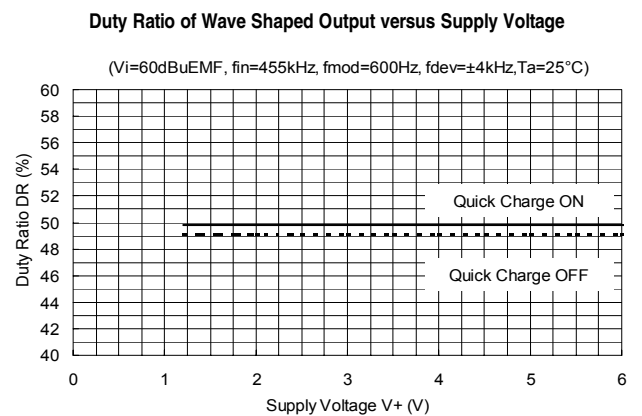
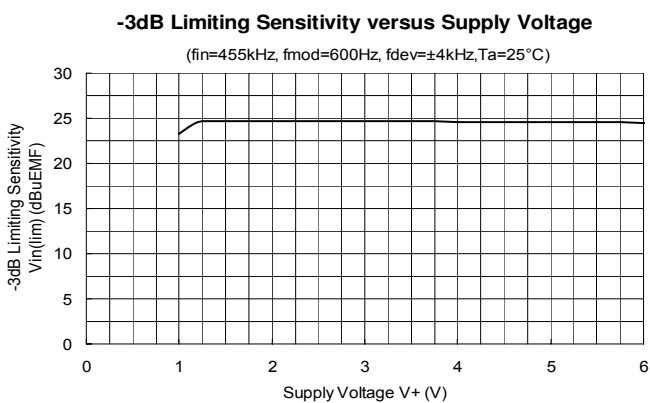
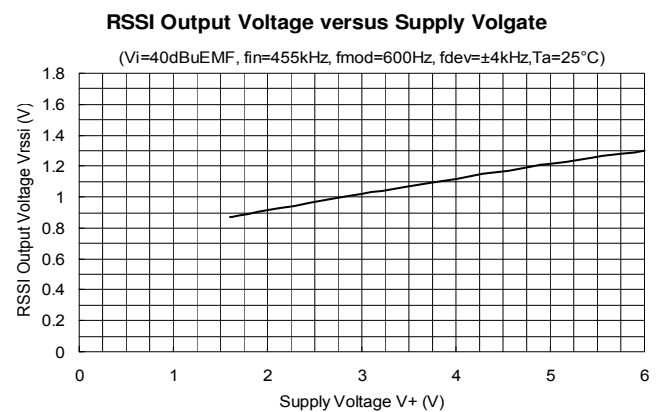
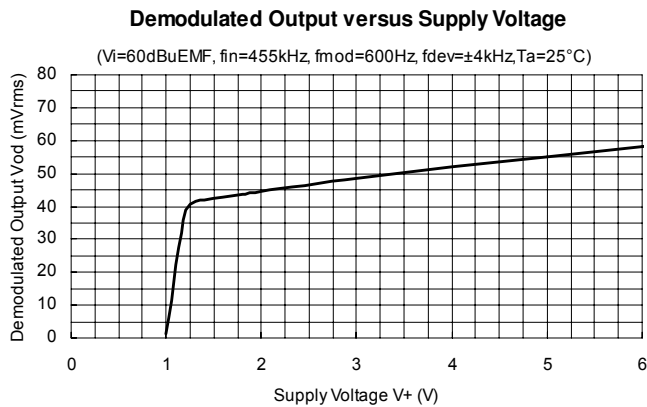
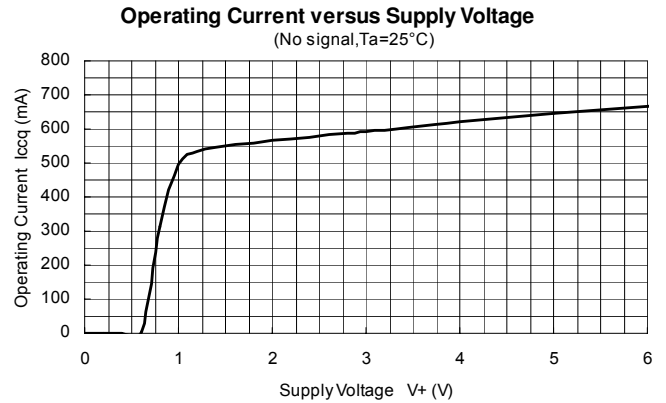
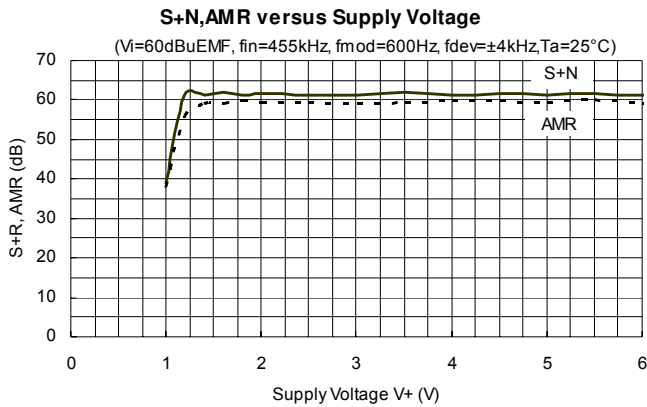

S+N, AMR versus IF Input Level

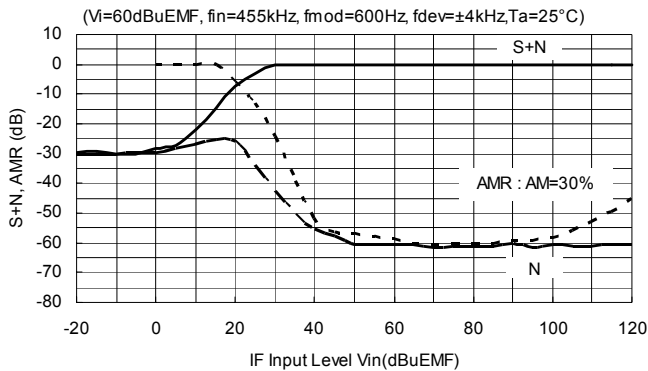

S-Curve Characteristics

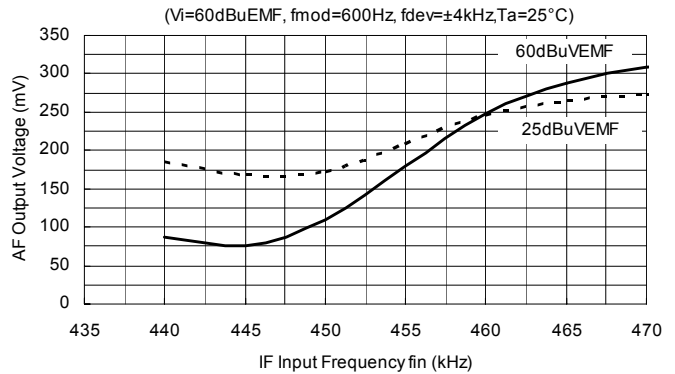

RSSI Output Level versus IF Input Level

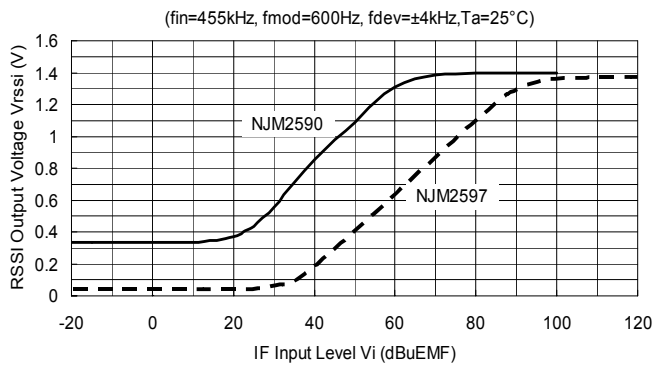

Quick Charge/Discharge Current versus FSK Reference Input Voltage

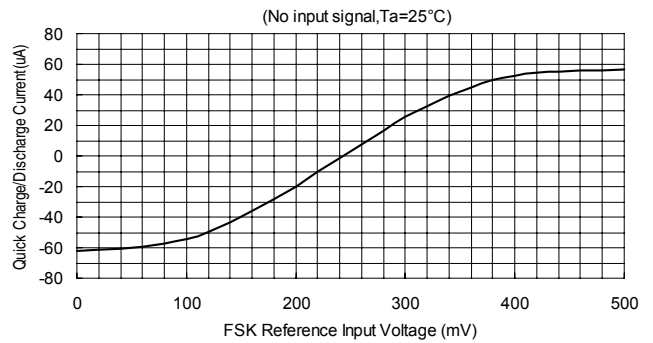

IF Detuning Characteristics

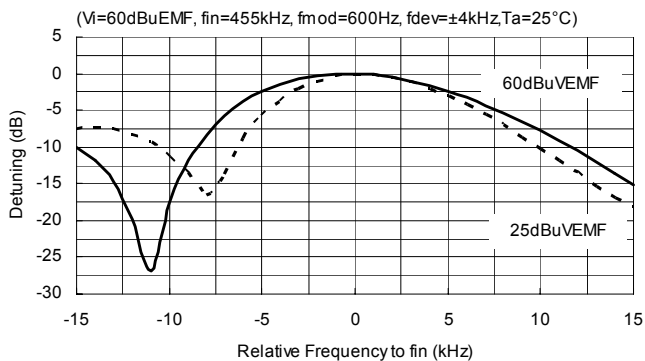

Carrier Sense Output Characteristics

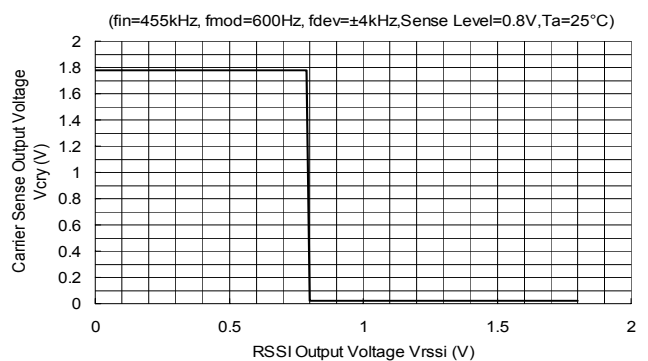

Operating Current versus Ambient Temperature

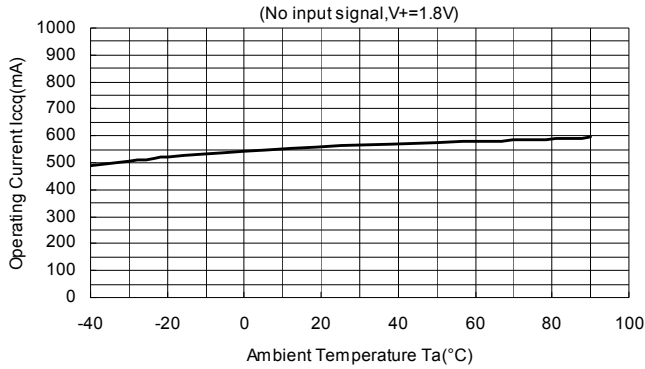

-3dB Limiting Sensitivity versus Ambient Temperature

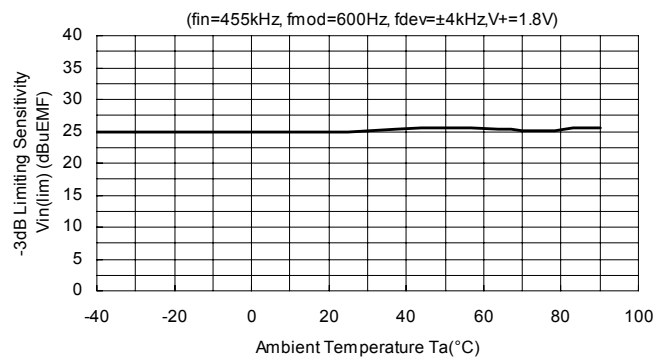

S+N versus Ambient Temperature

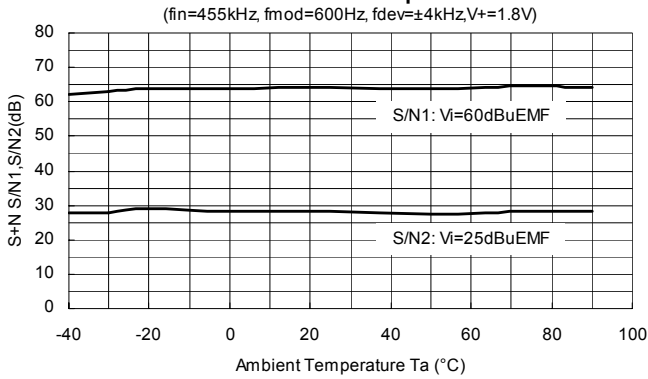

Demodulated Output Level versus Ambient Temperature

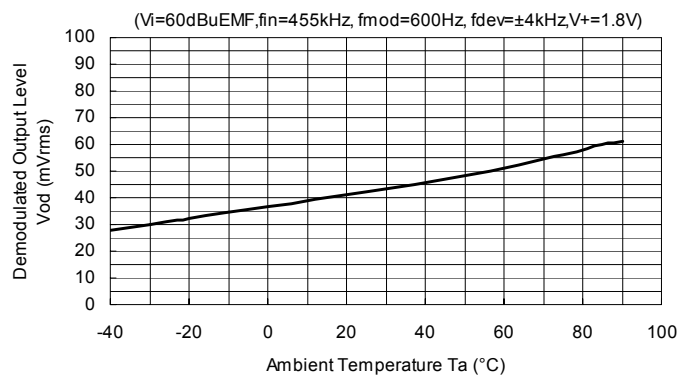

Duty Ratio of Wave Shaped Output versus Ambient Temperature

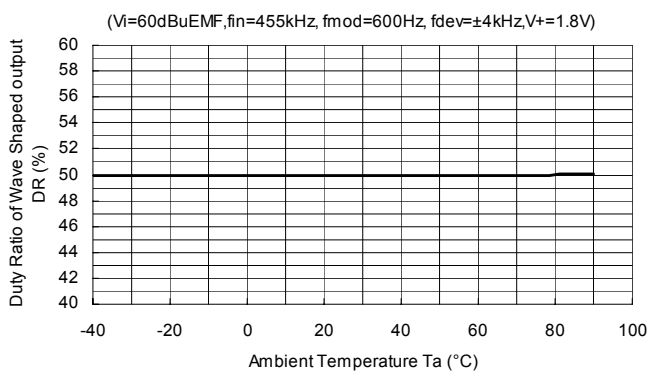

AM Rejection Ratio versus Ambient Temperature

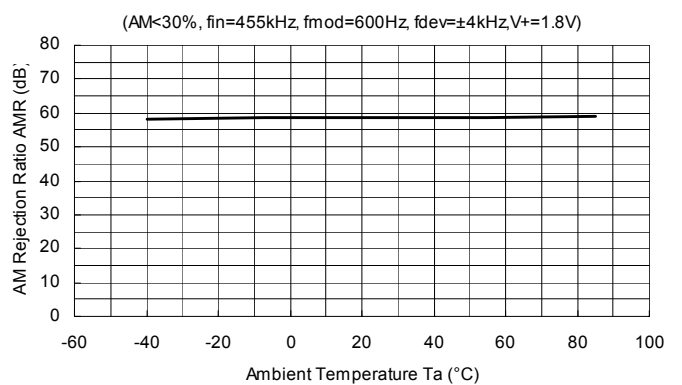

Quick Charge/Discharge Current versus Ambient Temperature

($V_{FSKOUT} = GND, V_{LOFOUT} = 0.18V, V_+ = 1.8V$)

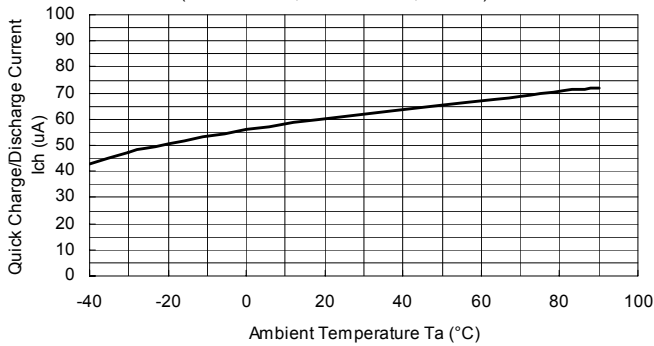

RSSI Output Resistance versus Ambient Temperature

($V_i = 40dBuEMF, f_{in} = 455kHz, f_{mod} = 600Hz, f_{dev} = \pm 4kHz, V_+ = 1.8V$)

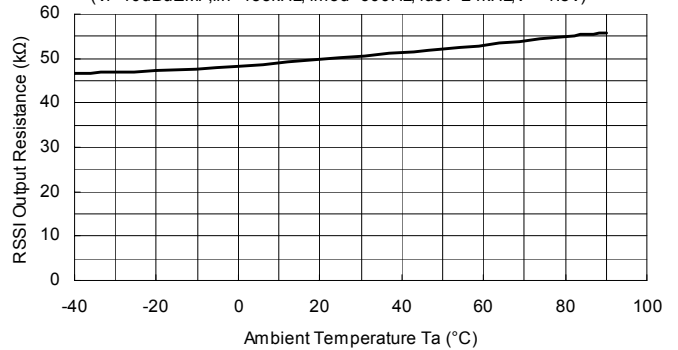

RSSI Output Voltage versus Ambient Temperature

($V_i = 40dBuEMF, f_{in} = 455kHz, f_{mod} = 600Hz, f_{dev} = \pm 4kHz, V_+ = 1.8V$)

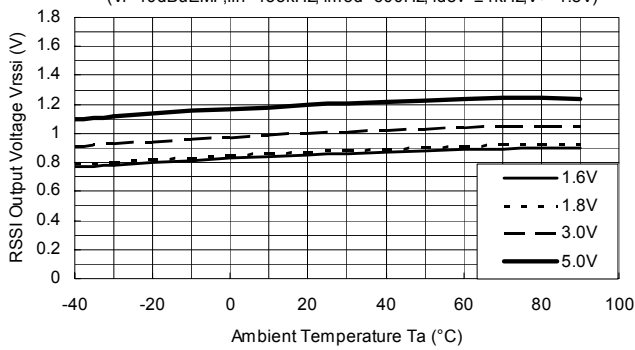

[CAUTION]

The specifications on this databook are only given for information, without any guarantee as regards either mistakes or omissions. The application circuits in this databook are described only to show representative usages of the product and not intended for the guarantee or permission of any right including the industrial rights.