

## RF Modulator for VHF Band

### DESCRIPTION

The NJM2536A is a RF modulator IC especially designed for VHF band RF modulator and consists of video clamp circuit, white clip circuit, video AM modulator and audio FM modulator, built into one chip.

### PACKAGE OUTLINE

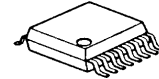

NJM2536AV

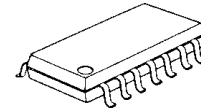

NJM2536AM

### FEATURES

- Operating Voltage 5V
- Picture-to-sound ratio is adjustable
- VHF Oscillator on chip
- Carrier-off switch function on chip
- Regulator on chip
- Bipolar Technology
- Package Outline:DMP/SSOP14

### BLOCK DIAGRAM

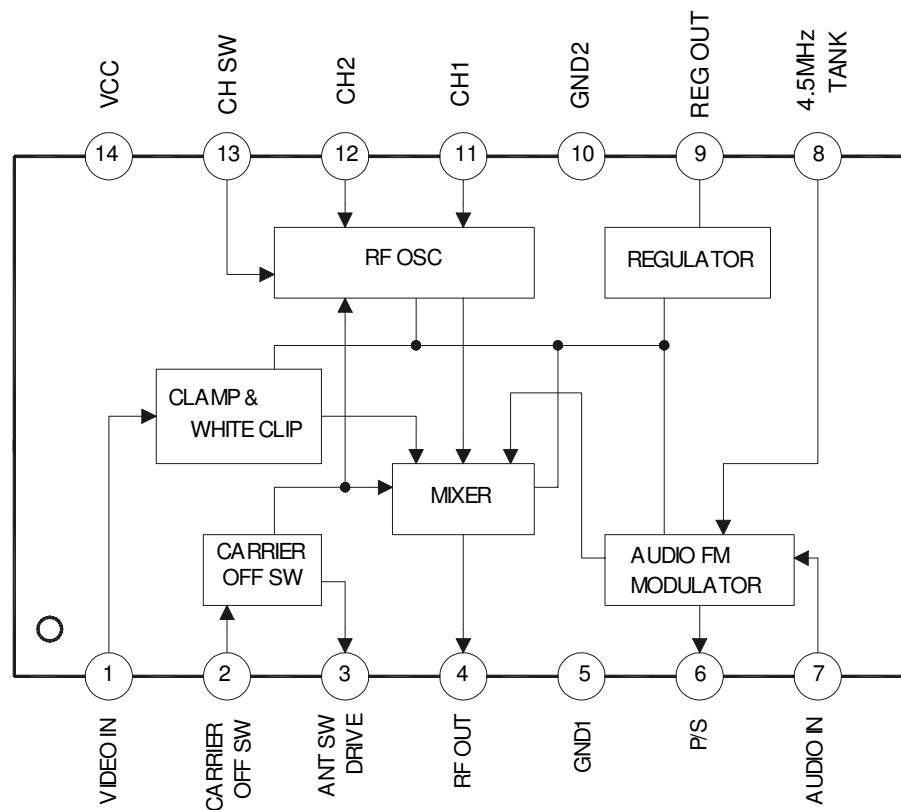

# NJM2536A

## ■ ABSOLUTE MAXIMUM RATINGS

( $T_A=25^\circ\text{C}$ )

Parameter	Symbol	Ratings	Unit
Supply Voltage	$V_{CC}$	7	V
Power Dissipation	$P_D$	300	mW
Input Voltage	$V_I$	-0.3 to $V_{CC}$	V
Operating Temperature Range	$T_{opr}$	-20 to +75	$^\circ\text{C}$
Storage Temperature Range	$T_{stg}$	-40 to +125	$^\circ\text{C}$

## ■ RECOMMENDED OPERATING VOLTAGE RANGE

( $T_A=25^\circ\text{C}$ )

Parameter	Condition	Symbol	Min.	Typ.	Max.	Unit
Operating Voltage		$V_{CC}$	4.5	5.0	5.5	V

## ■ ELECTRICAL CHARACTERISTICS

( $V_{CC}=5\text{V}, T_A=25^\circ\text{C}$ )

Parameter	Condition	Symbol	Min.	Typ.	Max.	Unit
Operating Current	No video/audio input signal, CARRIER OFF SW(Pin2)=5V	$I_{CC}$	13.5	16.0	22.5	mA
ANT SW DRIVE Output Voltage -1	CARRIER OFF SW(Pin2)=5V $I_D=26\text{mA}$	$V_{ANT1}$	3.7	4.0	4.3	V
ANT SW DRIVE Output Voltage -2	CARRIER OFF SW(Pin2)=Open $V_{CC}=2\text{V}$	$V_{ANT2}$	0	0.065	0.1	V
Video Output Level (Note 1)	Video input signal(Pin1)= $0.5V_{PP}$	$V_O$	(83)	86	(89)	dBu
Video Modulation Depth (Note 1)	Video input signal(Pin1)= $0.5V_{PP}$	mp	(70)	76	(82)	%
Video Limiter Modulation Depth (Note 1)	Video input signal(Pin1)= $1.0V_{PP}$	mpmax	(85)	94	(98)	%
Differential Gain	Video input signal(Pin1)= $0.5V_{PP}$ Staircase	DG	-	$\pm 3$	-	%
Differential Phase	Video input signal(Pin1)= $0.5V_{PP}$ Staircase	DP	-	$\pm 3$	-	deg
Picture-to-sound Ratio (Note 1)	Video input signal(Pin1)= $0.5V_{PP}$	PS	(11)	13	(15)	dB
Sound FM Modulation Sensitivity	Deviation of fs per 100mV	$\beta_b$	-	0.51	-	KHz/mV
Audio Distortion	Audio input signal(Pin7)= $0.05V_{PP}$ 1kHz sine wave	THD	-	0.3	-	%
Audio Signal-to-noise Ratio	Sound Modulation 60% 1kHz sine wave	ASN	-	60	-	dB
Maximum Sound FM Modulation	Audio input signal(Pin7)= $1.0V_{PP}$ 1kHz sine wave	msmax	-	700	-	%

(Note 1) Because AC characteristics largely depends on application circuit, these parameters are specified by the DC characteristics as shown in next page.

■ **DC ELECTRICAL CHARACTERISTICS** ( $V_{CC}=5V, Pin2=2.5V, T_A=25^\circ C$ , otherwise noted. All measurements performed in the DC test circuit are shown in next page)

Parameter	Condition (Note 2)	Symbol	Min.	Typ.	Max.	Unit
Video Output Signal Amplitude 1	$Gw1=Gvwh1-Gwvl1$	Gw1	62.4	85	124.5	mV
Video Output Signal Amplitude 2	$Gw2=Gvwh2-Gwvl2$	Gw2	62.4	85	124.5	mV
Video Modulation Depth	$Mp=((Gw1-Mw)/Gw1) \times 100$ where $Mw=Mwh-Mwl$	Mp	70	76	82	%
Video Limiter Modulation Depth (Note 2)	$Mpmax=((Gw1-Wc)/Gw1) \times 100$ where $Wc=Wch-Wcl$	Mpmax	85	94	98	%
Picture-to-sound Ratio	$Ps=Psh-Psl$	Ps	-70	-45	-35.1	mV

(Note 2) Explanation of symbols

- $V_v$  : VIDEO IN output voltage at Pin1
- $V_{11h}$  : CH1 output voltage at Pin11  
CH SW (Pin13) input = 2.5V
- $V_{12h}$  : CH1 output voltage at pin12  
CH SW (Pin13) input = 0.5V
- $Gvwh1$ : RF OUT output voltage at Pin4  
VIDEO IN (Pin 1) input =  $V_v$ , CH1 (Pin11) =  $V_{11h} + 0.15V$ , CH SW (Pin13) input = 2.5V
- $Gwvl1$  : RF OUT output voltage at Pin4  
VIDEO IN (Pin 1) input =  $V_v$ , CH1 (Pin11) =  $V_{11h} - 0.15V$ , CH SW (Pin13) input = 2.5V
- $Gvwh2$ : RF OUT output voltage at Pin4  
VIDEO IN (Pin 1) input =  $V_v$ , CH2 (Pin12) =  $V_{12h} + 0.15V$ , CH SW (Pin13) input = 0.5V
- $Gwvl2$ : RF OUT output voltage at Pin4  
VIDEO IN (Pin 1) input =  $V_v$ , CH2 (Pin12) =  $V_{12h} - 0.15V$ , CH SW (Pin13) input = 0.5V
- $Mwh$  : RF OUT output voltage at Pin4  
VIDEO IN (Pin 1) input =  $V_v + 0.43V$ , CH1 (Pin11) =  $V_{11h} + 0.15V$ , CH SW (Pin13) input = 2.5V
- $Mwl$  : RF OUT output voltage at Pin4  
VIDEO IN (Pin 1) input =  $V_v + 0.43V$ , CH1 (Pin11) =  $V_{11h} - 0.15V$ , CH SW (Pin13) input = 2.5V
- $Wch$  : RF OUT output voltage at Pin4  
VIDEO IN (Pin 1) input =  $V_v + 0.8V$ , CH1 (Pin11) =  $V_{11h} + 0.15V$ , CH SW (Pin13) input = 2.5V
- $Wcl$  : RF OUT output voltage at Pin4  
VIDEO IN (Pin 1) input =  $V_v + 0.8V$ , CH1 (Pin11) =  $V_{11h} - 0.15V$ , CH SW (Pin13) input = 2.5V
- $VPs$  : P/S output voltage at Pin6  
CARRIER OFF SW (Pin 2) input = 2.5V
- $Psh$  : RF OUT output voltage at Pin4  
P/S (Pin 6) input =  $VPs + 0.2V$ , CH1 (Pin11) = 2.4V, CH SW (Pin13) input = 2.5V
- $Psl$  : RF OUT output voltage at Pin4  
P/S (Pin 6) input =  $VPs - 0.2V$ , CH1 (Pin11) = 2.4V, CH SW (Pin13) input = 2.5V

# NJM2536A

## ■ AC TEST CIRCUIT

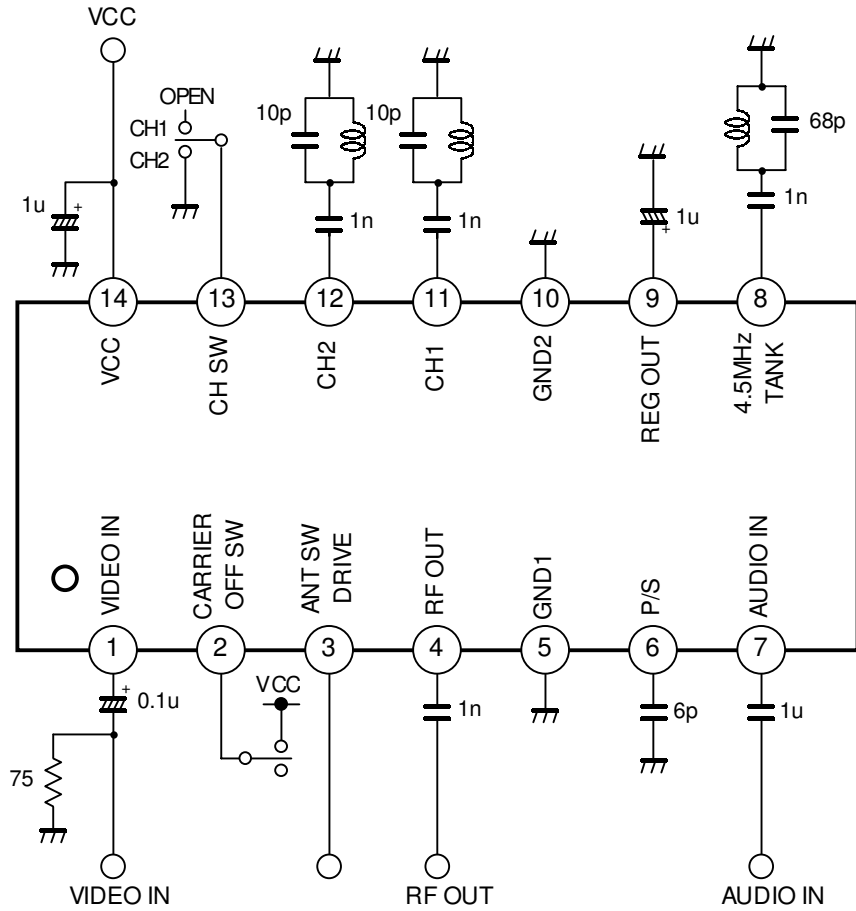

## ■ DC TEST CIRCUIT

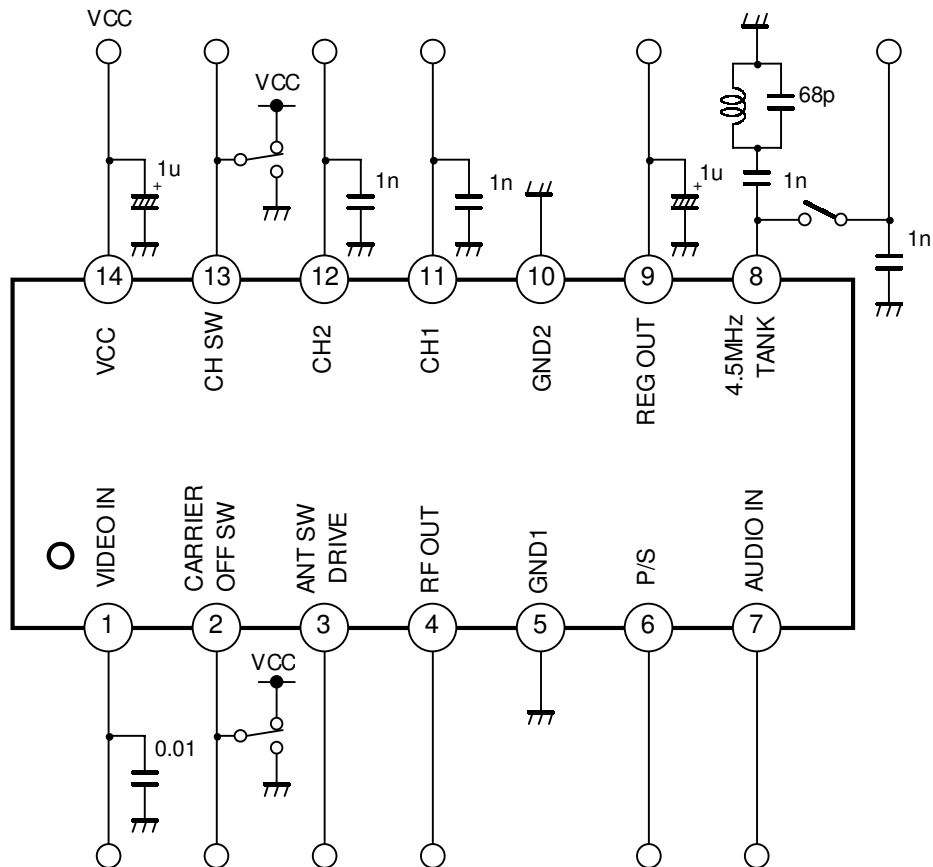

## ■ TERMINAL CHARACTERISTICS

No.	Symbol	Typ. DC Voltage (V)	Equivalent Circuit	Function
1	VIDEO IN	1.9		Video Signal Input
2	CARRIER OFF SW	-		Picture Carrier-Off Switch
3	ANT SW DRIVE	4 (Pin2=High) 0 (Pin2=Low)		ANT Switch Drive Voltage Output
4	RF OUT	4		RF Signal Output
5	GND1	0		GND terminal except for oscillator circuit
6	P/S	2.8		Picture-to-sound Ratio Adjust

# NJM2536A

No.	Symbol	Typ. DC Voltage (V)	Equivalent Circuit	Function
7	AUDIO IN	0.035		Audio Signal Input
8	4.5MHz TANK	2.9		4.5MHz Tank Coil for Sound FM Modulation Circuit
9	REG OUT	4		Regulator Output
10	GND2	0		GND for Oscillator Circuit
11	CH1	2.24 (OSC:ON) 2.30 (OSC:OFF)		RF Oscillator Pin (Base)
12	CH2	2.24 (OSC:ON) 2.30 (OSC:OFF)		RF Oscillator Pin (Base)

No.	Symbol	Typ. DC Voltage (V)	Equivalent Circuit	Function
13	CH SW	2.38		Output channel Select Switch
14	VCC	5		Power Supply

## ■ TYPICAL CHARACTERISTICS

$T_A=25^\circ\text{C}$

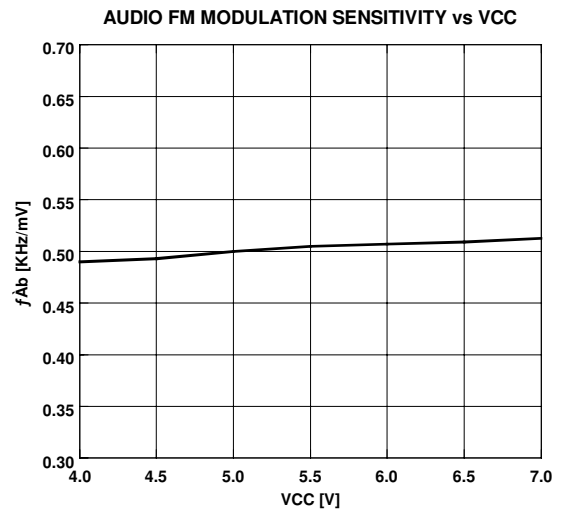
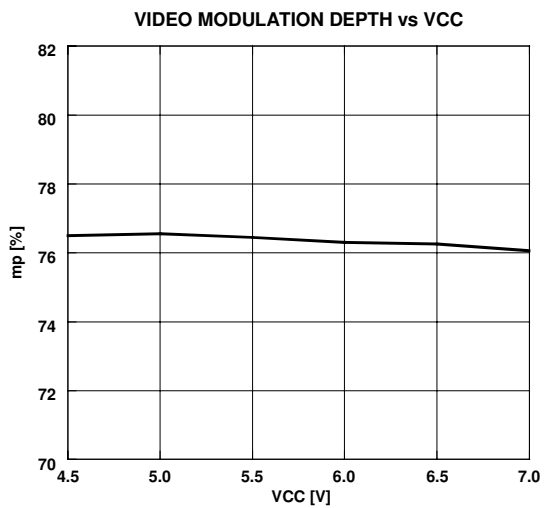
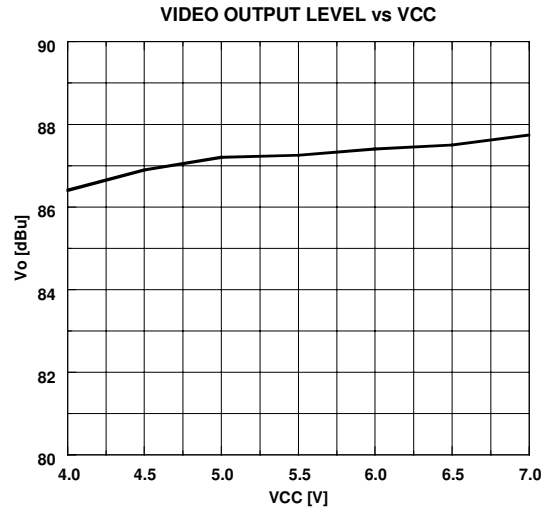
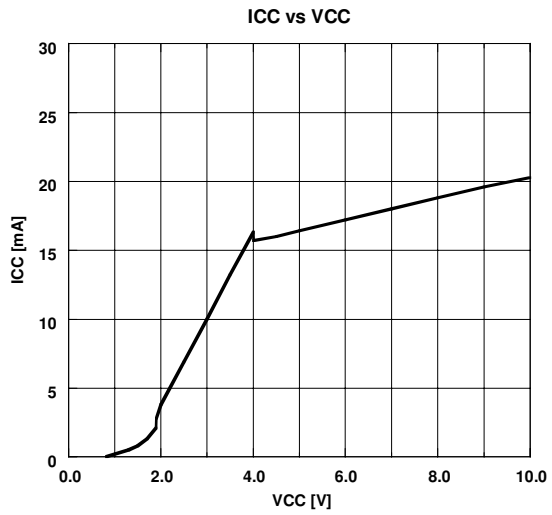



---

# MEMO

[CAUTION]

The specifications on this databook are only given for information, without any guarantee as regards either mistakes or omissions. The application circuits in this databook are described only to show representative usages of the product and not intended for the guarantee or permission of any right including the industrial rights.