

Ambient Light Sensor

■ GENERAL DESCRIPTION

The NJL7502L is the photo transistor which spectral response is similar to human eye.

■ FEATURES

1. Peak wavelength 560 nm
2. Photo current 33 μ A typ. Condition : White LED, 100Lux
3. Lead pin package

■ APPLICATIONS

Room light, Toy, TV, PDP, Clock, Refrigerator, etc.

to adjust the luminance of display

to control ON/OFF

Replacement of CdS

■ ABSOLUTE MAXIMUM RATINGS (Ta=25°C)

PARAMETER	SYMBOL	RATINGS	UNIT
Collector - Emitter Voltage	V_{CEO}	70	V
Emitter - Collector Voltage	V_{ECO}	10	V
Photocurrent	I_L	10	mA
Power Dissipation	P_D	150	mW
Operating Temperature	T_{opr}	-40 to +85	°C
Storage Temperature	T_{stg}	-40 to +100	°C
Soldering Temperature	T_{sol}	260	°C

■ ELECTRO-OPTICAL CHARACTERISTICS (Ta=25°C)

PARAMETER	SYMBOL	TEST CONDITION	MIN	TYP	MAX	UNIT
Photocurrent 1	I_{L1}	$V_{CE}=5V$, Light source A, 100Lux	—	46	—	μ A
Photocurrent 2	I_{L2}	$V_{CE}=5V$, White LED, 100Lux	15	33	73	μ A
Dark Current	I_D	$V_{CE}=20V$	—	—	0.1	μ A
Peak Wavelength	λ_P	—	—	560	—	nm
Collector - Emitter Saturation Current	$I_{CE(sat)}$	$V_{CE}=0.24V$, White LED, 100Lux	10	—	—	μ A
Emitter - Collector Voltage	V_{ECL}	$I_{ECL}=1\mu A$, White LED, 100Lux	9	—	—	V
Half Angle	$\Theta_{1/2}$	—	—	± 20	—	deg.
Rise Time	t_r	$V_{CE}=5V$, $I_C=1mA$, $R_L=100\Omega$	—	10	—	μ s
Fall Time	t_f	$V_{CE}=5V$, $I_C=1mA$, $R_L=100\Omega$	—	10	—	μ s

■ TEST CIRCUIT

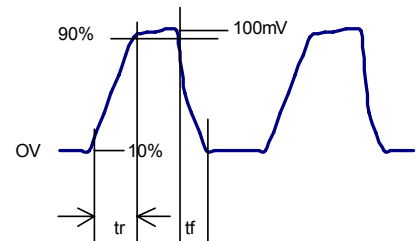
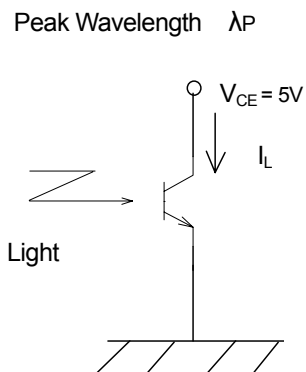
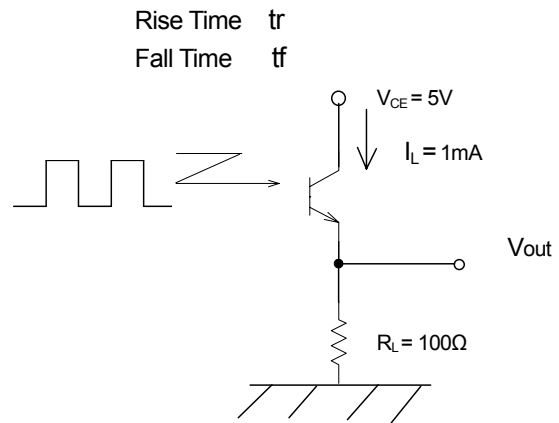
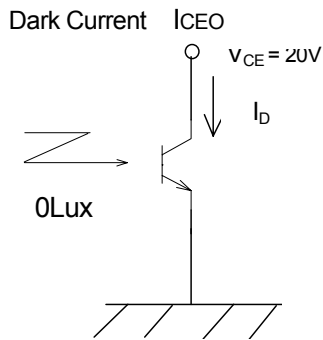
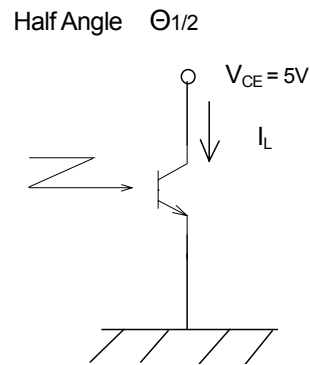
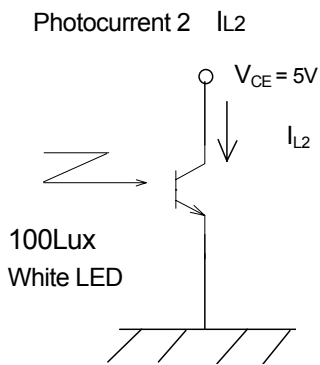
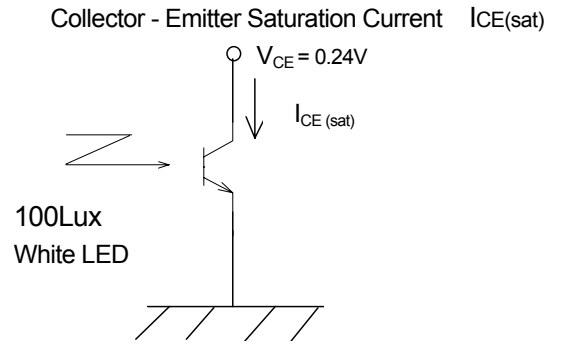
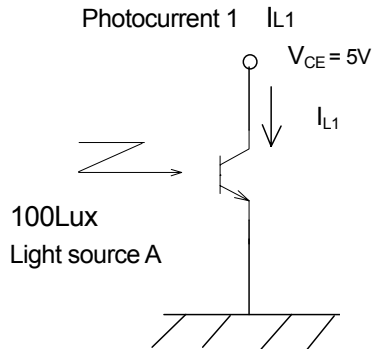

■ OUTLINE (TYP.)

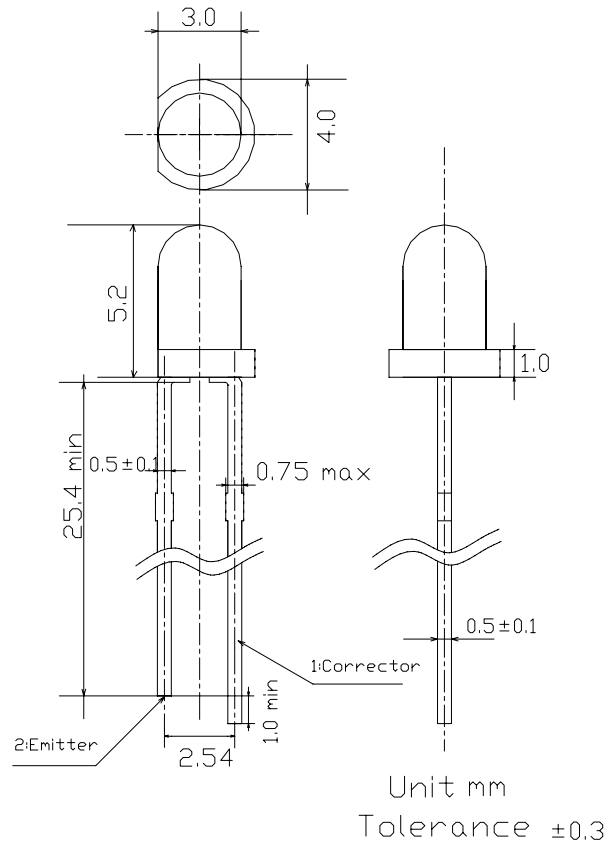

■ TYPICAL CHARACTERISTICS

Spectral Response ($T_a=25^\circ\text{C}$)

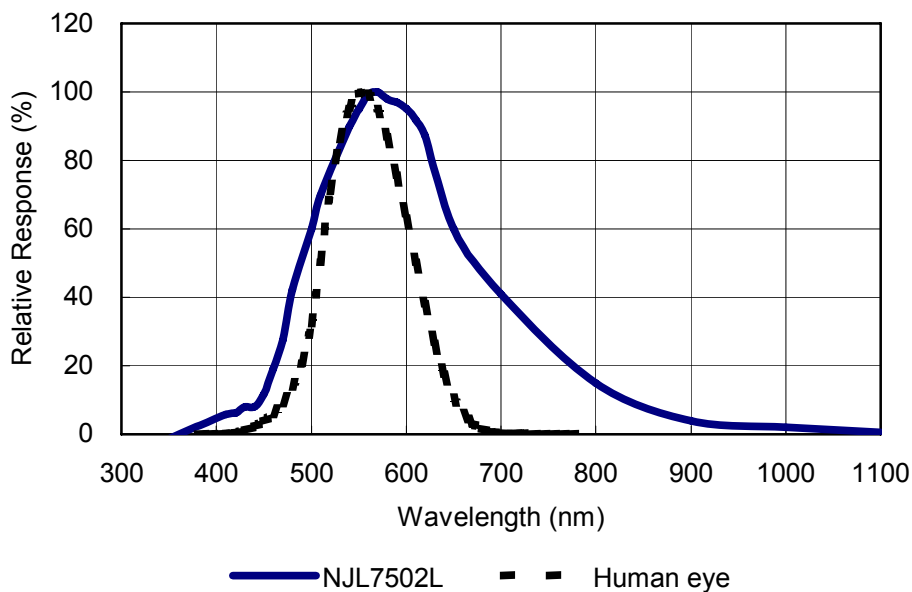

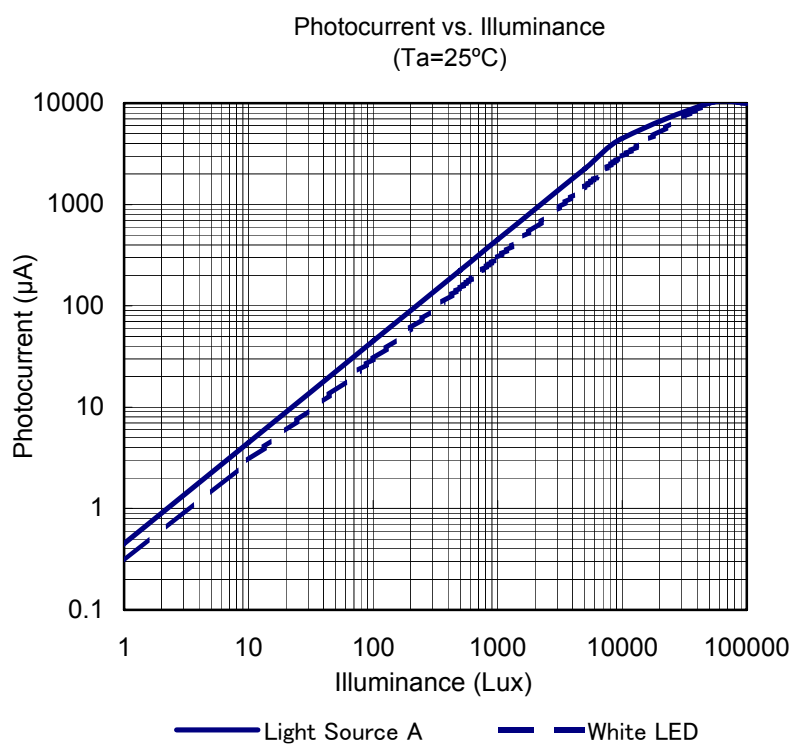
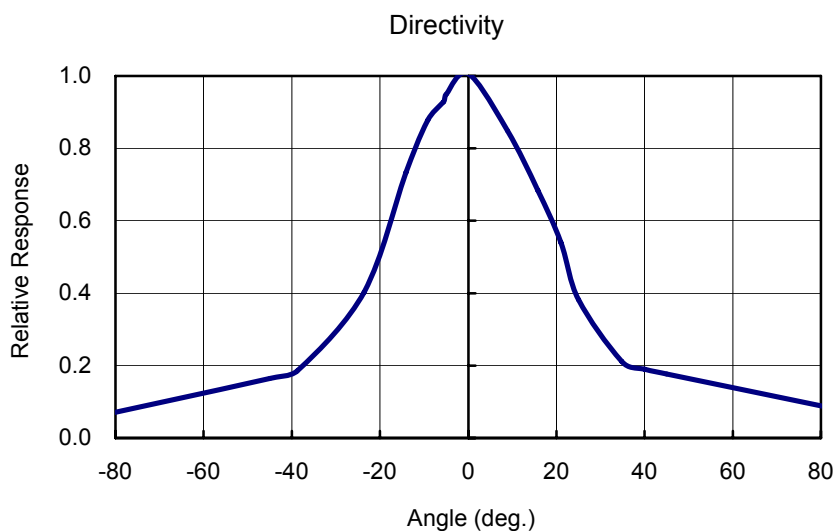

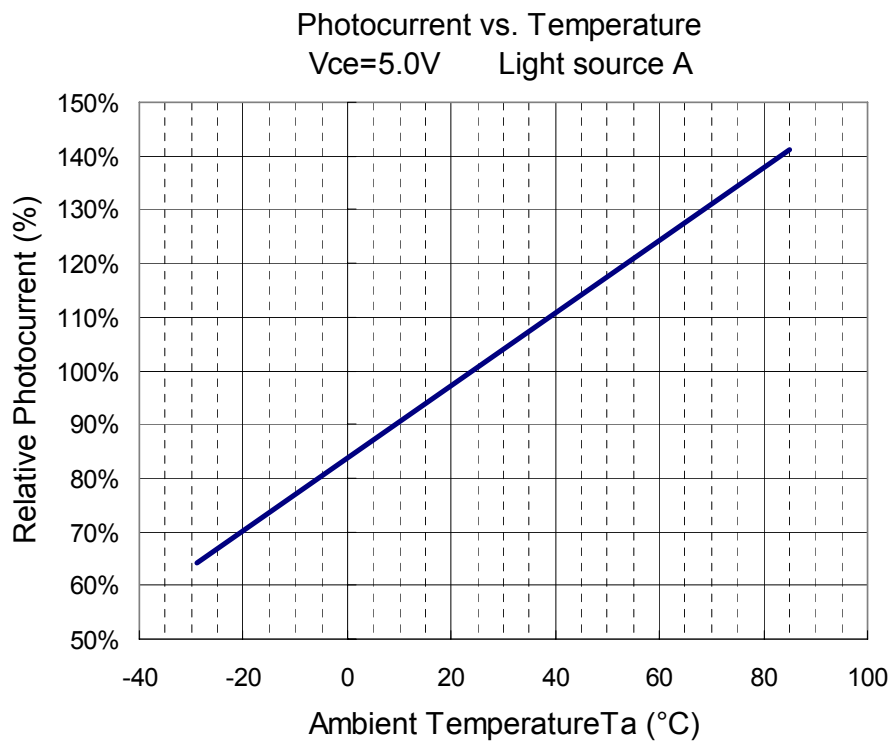
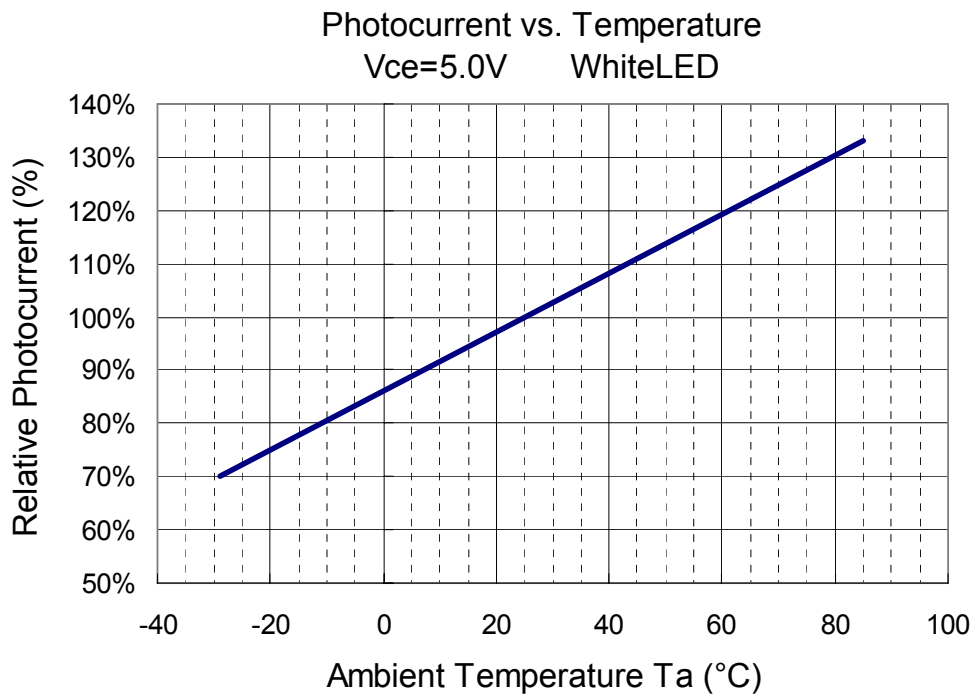

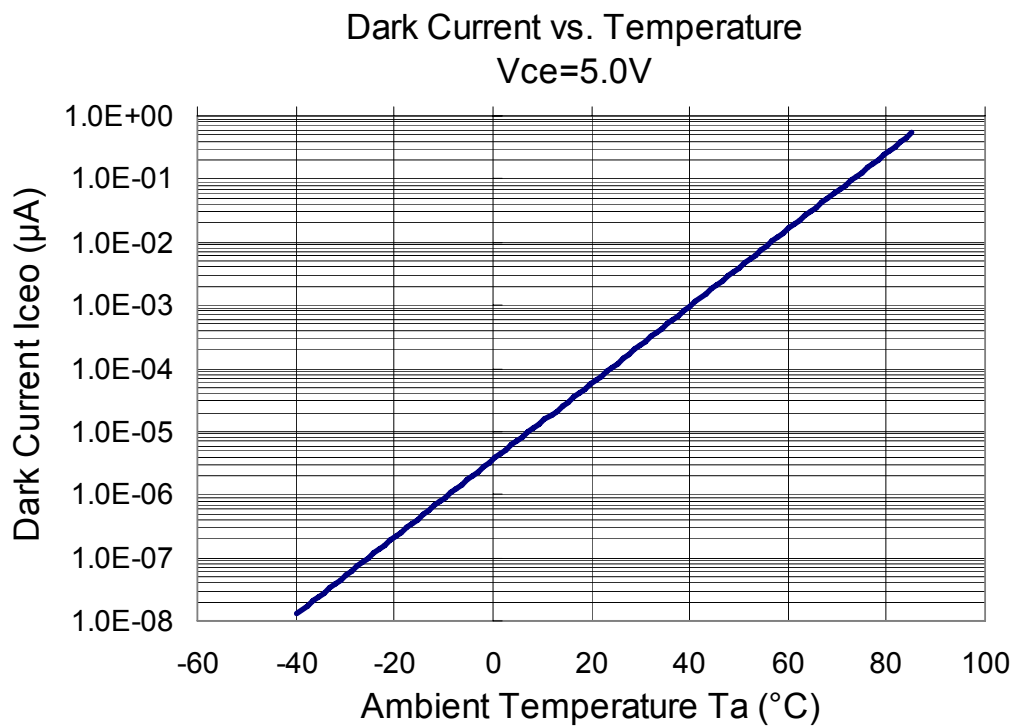

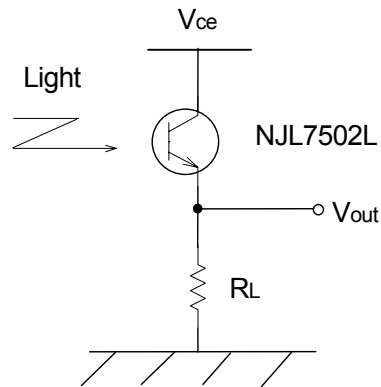

NJL7502L White LED Vce=5.0V

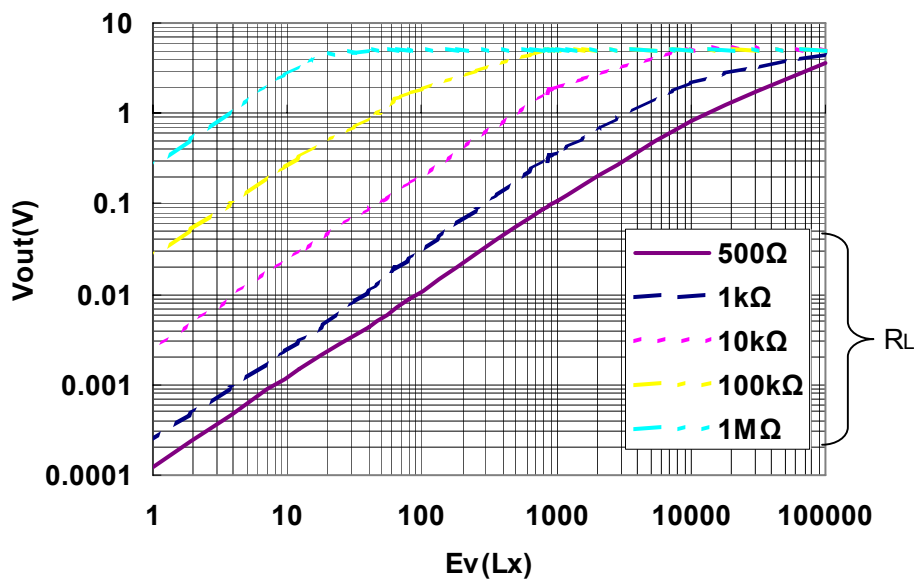

NJL7502L Light Source A Vce=5.0V

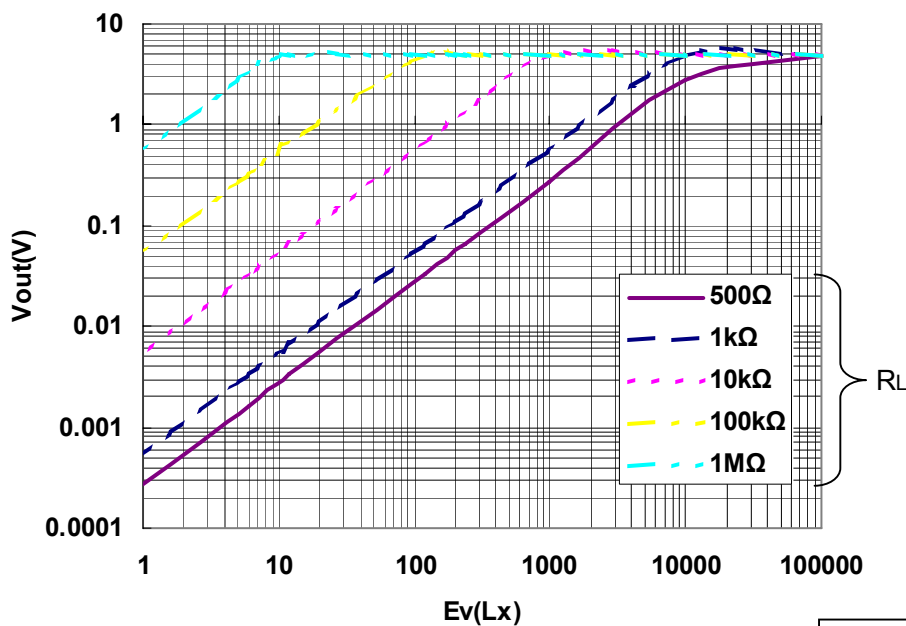

[CAUTION]
The specifications on this databook are only given for information, without any guarantee as regards either mistakes or omissions. The application circuits in this databook are described only to show representative usages of the product and not intended for the guarantee or permission of any right including the industrial rights.