

## 3-Input / 1-Output Stereo Audio Selector

### ■ GENERAL DESCRIPTION

The **NJM2753** is 3-Input / 1-Output Stereo Audio Selector.

The **NJM2753** consists of switches and buffer operational amplifiers.

Based on the internal switch op-amp technology, the **NJM2753** features lower output noise, lower distortion and higher channel separation than the general Multiplexers or Analogue Switches.

The **NJM2753** contains compatibility with NJM2752(2in-1out SW), NJM2755(4in-1out SW).

### ■ PACKAGE OUTLINE

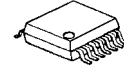

**NJM2753V**

### ■ APPLICATIONS

- LCD-TV/PDP-TV
- Car Stereo
- Any Audio System

### ■ FEATURES

- Operating Voltage 4.7 to 10V
- 3-Input / 1-Output Stereo Audio Selector
- Low Output Noise -114dBV typ.
- Low Distortion 0.0009% typ.
- Bipolar Technology
- Package Outline SSOP14

### ■ BLOCK DIAGRAM

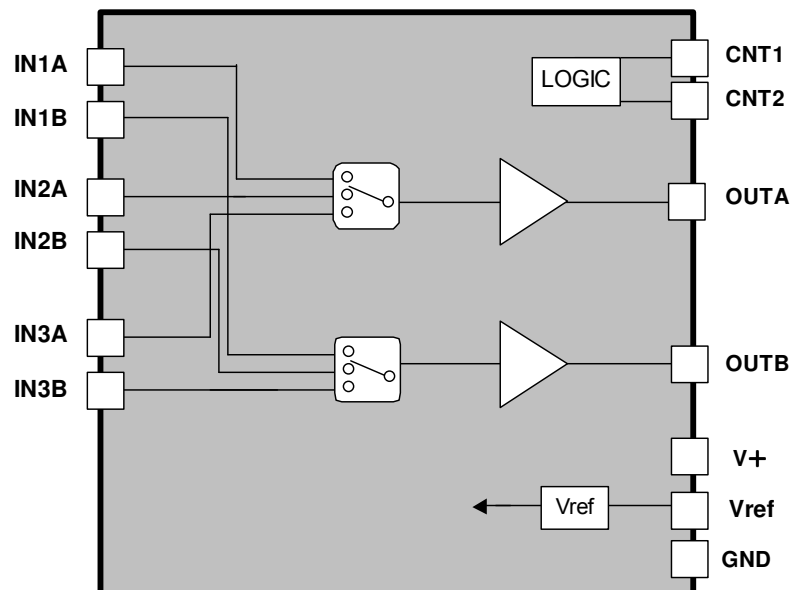

# NJM2753

## ■ PIN CONFIGURATIONS NJM2753 SSOP14

### SSOP14

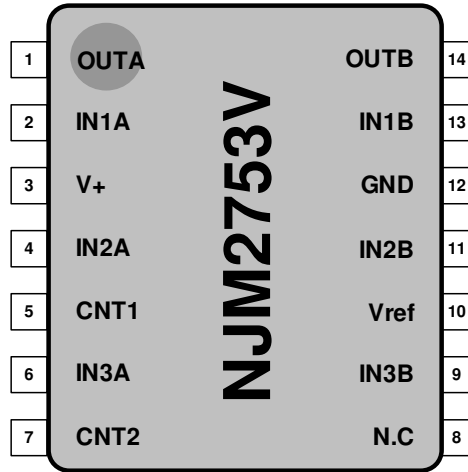

PIN.No.	SYMBOL	FUNCTION	PIN.No.	SYMBOL	FUNCTION
1	OUTA	Ach Output Terminal	8	N.C	No Connection
2	IN1A	Ach Input Terminal1	9	IN3B	Bch Input Terminal3
3	V+	Power Supply Terminal	10	Vref	Reference Terminal
4	IN2A	Ach Input Terminal2	11	IN2B	Bch Input Terminal2
5	CNT1	Control Switch Terminal1	12	GND	GND Terminal
6	IN3A	Ach Input Terminal2	13	IN1B	Bch Input Terminal1
7	CNT2	Control Switch Terminal2	14	OUTB	Bch Output Terminal

### [Reference]

The NJM2753 contains compatibility with NJM2752 (2in-1out SW), NJM2755 (4in-1out SW).

#### NJM2752

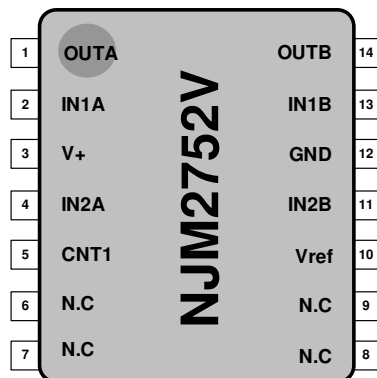

#### NJM2755

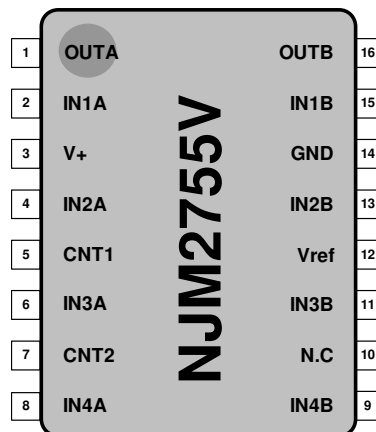

## ■ ABSOLUTE MAXIMUM RATINGS (Ta=25 °C)

PARAMETER	SYMBOL	RATING	UNIT
Supply Voltage	V <sup>+</sup>	12	V
Power Dissipation	P <sub>D</sub>	SSOP14 450 <sup>1)</sup> 570 <sup>2)</sup> <small>NOTE 1): EIA/JEDEC STANDARD Test board (76.2x114.3x1.6mm, 2layer, FR-4) mounting 2): EIA/JEDEC STANDARD Test board (76.2x114.3x1.6mm, 4layer, FR-4) mounting</small>	mW
Operating Temperature Range	T <sub>OPR</sub>	-40 to +85	°C
Storage Temperature Range	T <sub>STR</sub>	-40 to +150	°C

## ■ ELECTRICAL CHARACTERISTICS ( Ta=25 °C, V<sup>+</sup>=9V)

PARAMETER	SYMBOL	TEST CONDITION	MIN.	TYP.	MAX.	UNIT
Operating Voltage	V <sup>+</sup>		4.7	9.0	10	V
Supply Current	I <sub>CC</sub>	No Signal	-	10	15	mA
Reference Voltage	V <sub>REF</sub>		-	4.5	-	V
Voltage Gain	G <sub>V</sub>	V <sub>in</sub> =1V <sub>rms</sub> , f=1kHz	-1	0	1	dB
Total Harmonic Distortion	THD+N	V <sub>in</sub> =1V <sub>rms</sub> , f=1kHz	-	0.0009	0.03	%
Output Noise Voltage	V <sub>NO</sub>	A-Weighted	-	-114 (2)	-100 (10)	dBV (μV <sub>rms</sub> )
Maximum Output Voltage	V <sub>OM</sub>	f=1kHz, THD=1%	6 (2.0)	8 (2.5)	-	dBV (V <sub>rms</sub> )
Cross Talk	CT	V <sub>in</sub> =1V <sub>rms</sub> , f=1kHz, A-Weighted	85	100	-	dB
Channel Separation	CS	V <sub>in</sub> =1V <sub>rms</sub> , f=1kHz, A-Weighted	90	110	-	dB
Switch-ON Voltage Level	V <sub>CH</sub>		2.4	-	-	V
Switch-OFF Voltage Level	V <sub>CL</sub>		-	-	0.5	V
Input Impedance	R <sub>IN</sub>		-	100	-	kΩ
Output Impedance	R <sub>OUT</sub>		-	45	-	Ω

## ■ SWITCH CONTROL LOGIC

CNT2	CNT1	INPUT SELECTOR Ach / Bch
L	L	1
L	H	2
H	L / H	3

# NJM2753

## ■ TERMINAL DESCRIPTION

PIN No.	SYMBOL	FUNCTION	EQUIVALENT CIRCUIT	TERMINAL VOLTAGE
2 4 6 9 11 13	IN1A IN2A IN3A IN3B IN2B IN1B	Ach Input Terminal1 Ach Input Terminal2 Ach Input Terminal3 Bch Input Terminal3 Bch Input Terminal2 Bch Input Terminal1		V+/2
5 7	CNT1 CNT2	Control Switch Terminal1 Control Switch Terminal2		0V (GND)
1 14	OUTA OUTB	Ach Output Terminal Bch Output Terminal		V+/2
10	Vref	Reference Terminal		V+/2
3 12	V+ GND	Power Supply Terminal GND Terminal		V+ 0V

## MEASUREMENT CIRCUIT

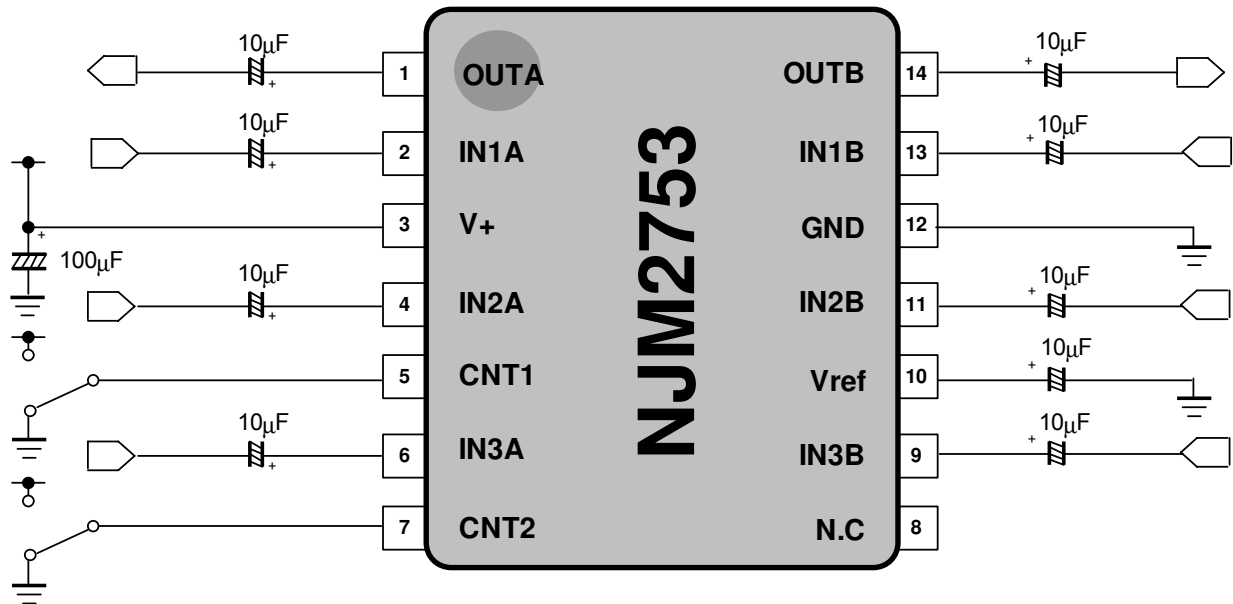

# NJM2753

## APPLICATION CIRCUIT

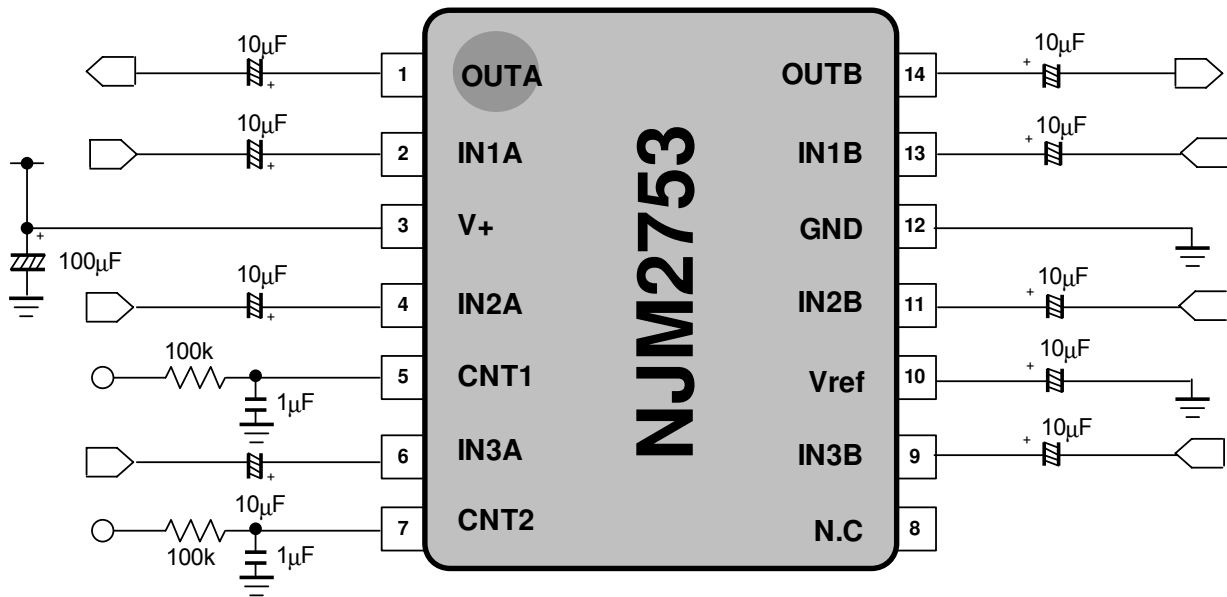

### Application note:

Resistor(100k) and capacitor(1µF) connected to CNT1 are added to reduce pop-noise.

The value of input capacitor connected to IN1A and IN2A depends on cut-off frequency(calculated by  $f_c=1/2\pi RC$ ) you need. R(input impedance)=100kΩ.

## TYPICAL CHARACTERISTICS

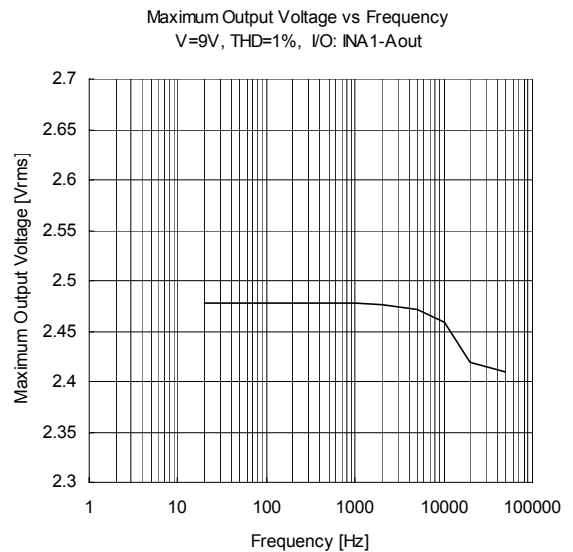
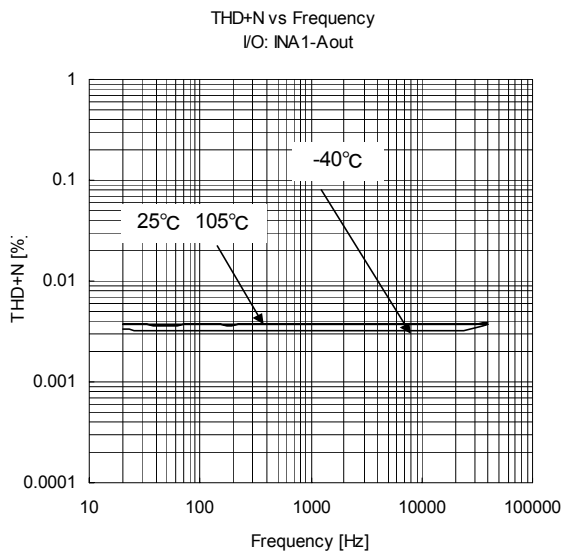
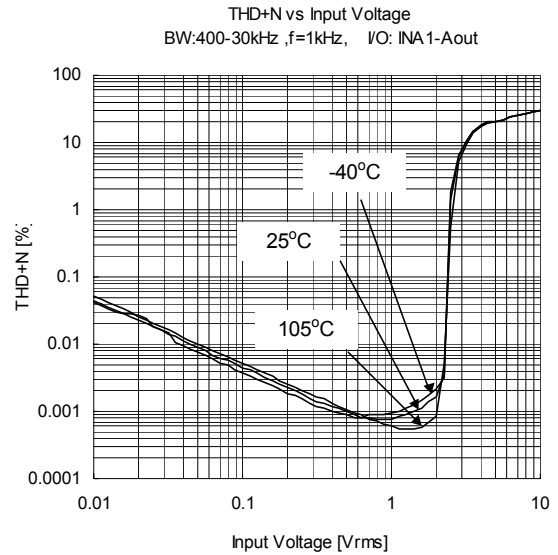
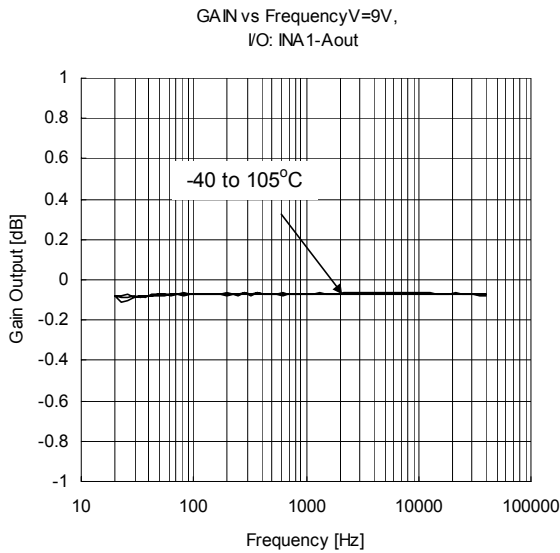
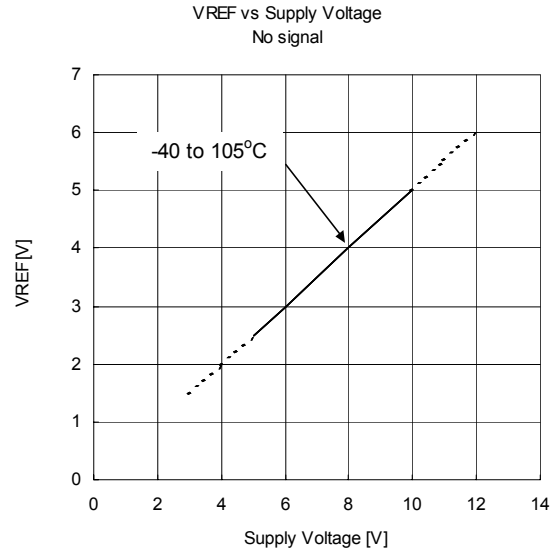
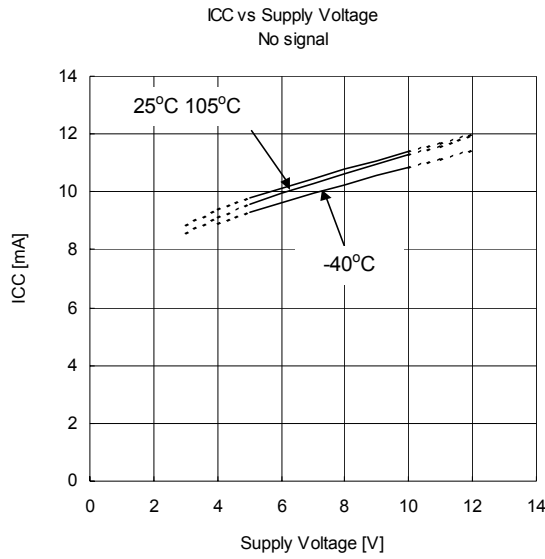

## TYPICAL CHARACTERISTICS

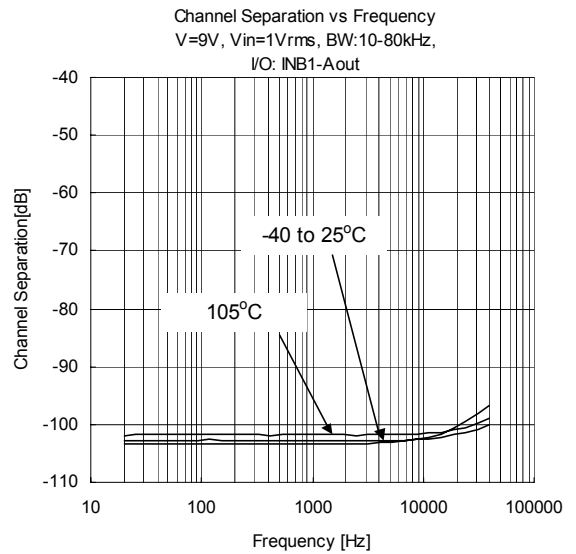
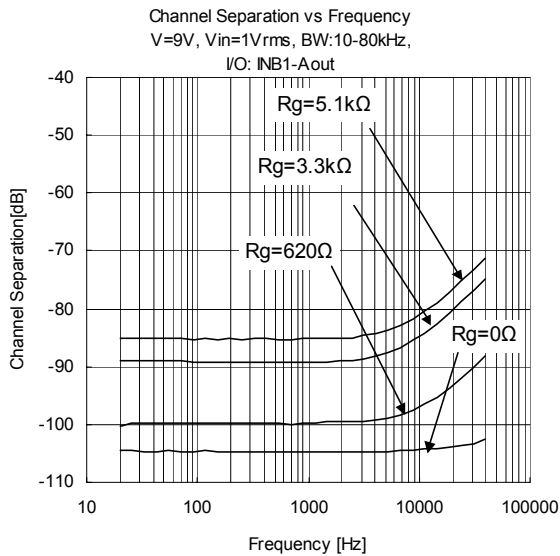
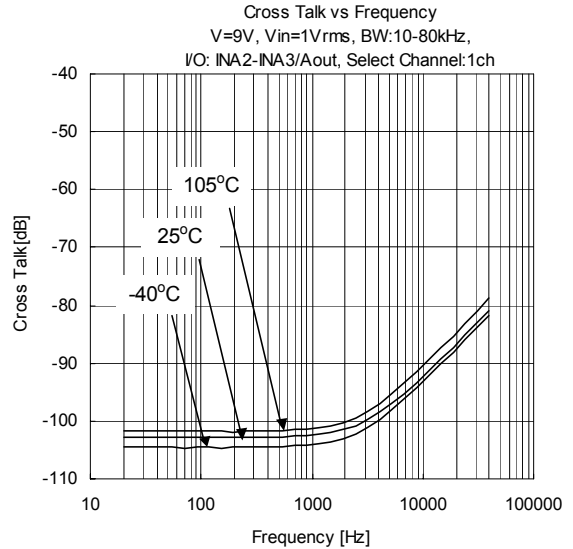
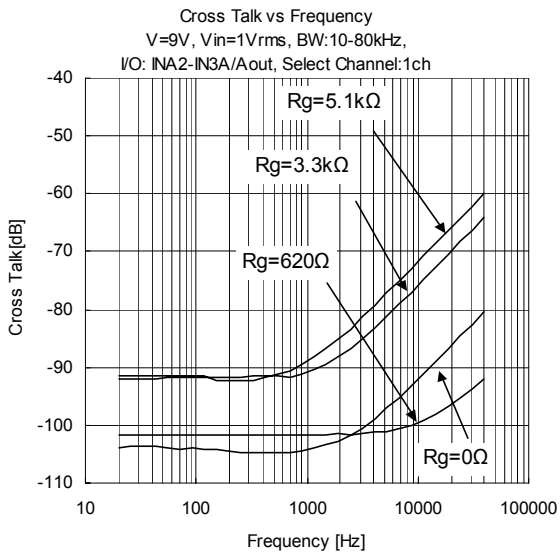
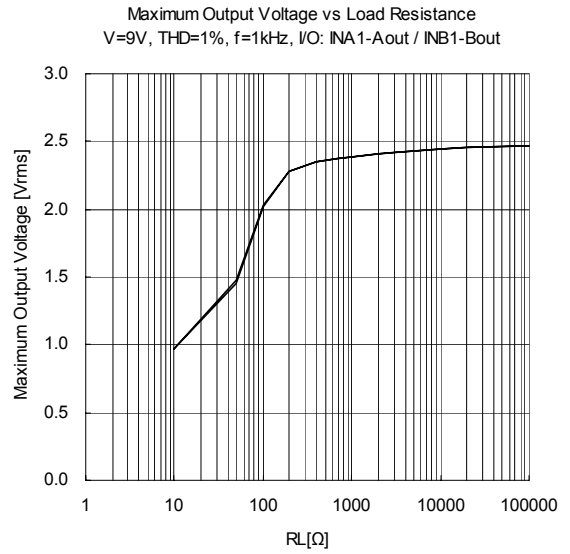
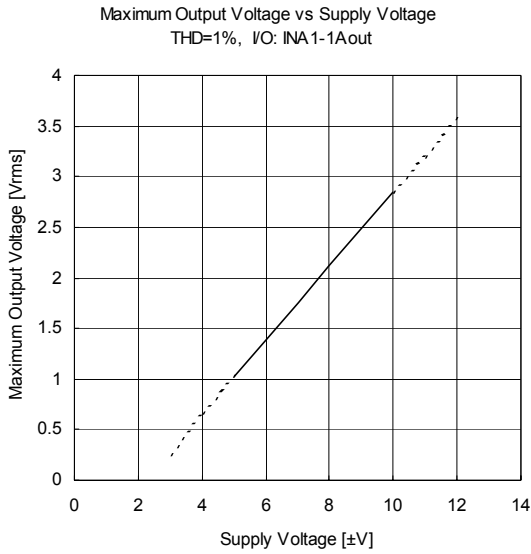



## TYPICAL CHARACTERISTICS

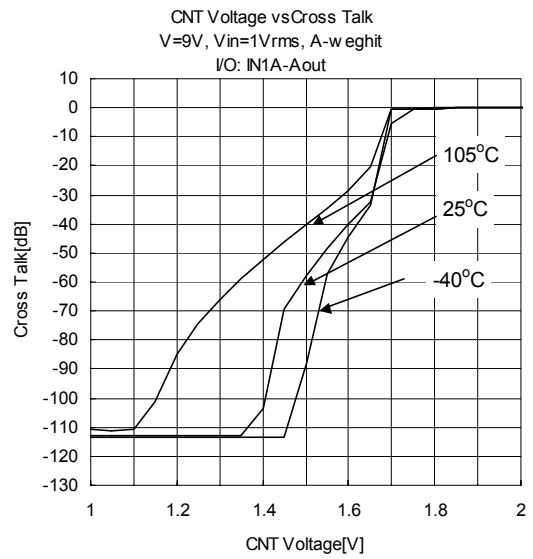
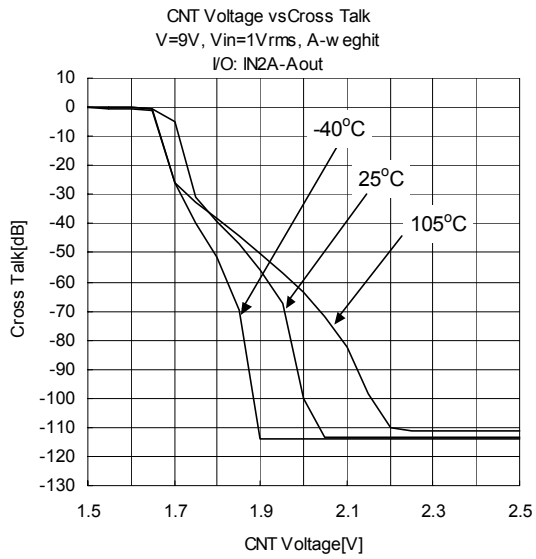

**[CAUTION]**

The specifications on this databook are only given for information, without any guarantee as regards either mistakes or omissions. The application circuits in this databook are described only to show representative usages of the product and not intended for the guarantee or permission of any right including the industrial rights.