

# ASSP For Power Supply Applications

BIPOLAR

## Switching Regulator Controller

# MB3817

### ■ DESCRIPTION

The MB3817 is a pulse width modulator (PWM) type switching regulator controller IC designed for low-voltage and high-speed operation. This can be used in applications as down-conversion or down/up-conversion (Zeta method).

With fewer external components and faster operating speed, the MB3817 enables reduction in power supply unit size, making it ideal for use with internal power supplies in compact, high-performance portable devices.

### ■ FEATURES

- Wide range of operating power supply voltages : 2.5 V to 18 V
- Built-in high-precision reference voltage generator :  $1.5 \text{ V} \pm 2\%$
- High speed operation is possible : Max 500 kHz
- Wide input voltage range of error amplifier : 0 V to  $V_{CC} - 0.9 \text{ V}$
- Built-in soft start function
- Built-in timer/latch-actuated short-circuiting protection circuit
- Totem-pole type output with adjustable on/off current (for PNP transistors)
- Built-in standby function
- Small package : SSOP-16P (FPT-16P-M05)

### ■ PACKAGE

16-pin Plastic SSOP

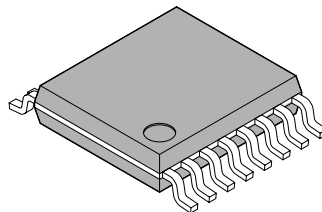

(FPT-16P-M05)

# MB3817

## ■ PIN ASSIGNMENT

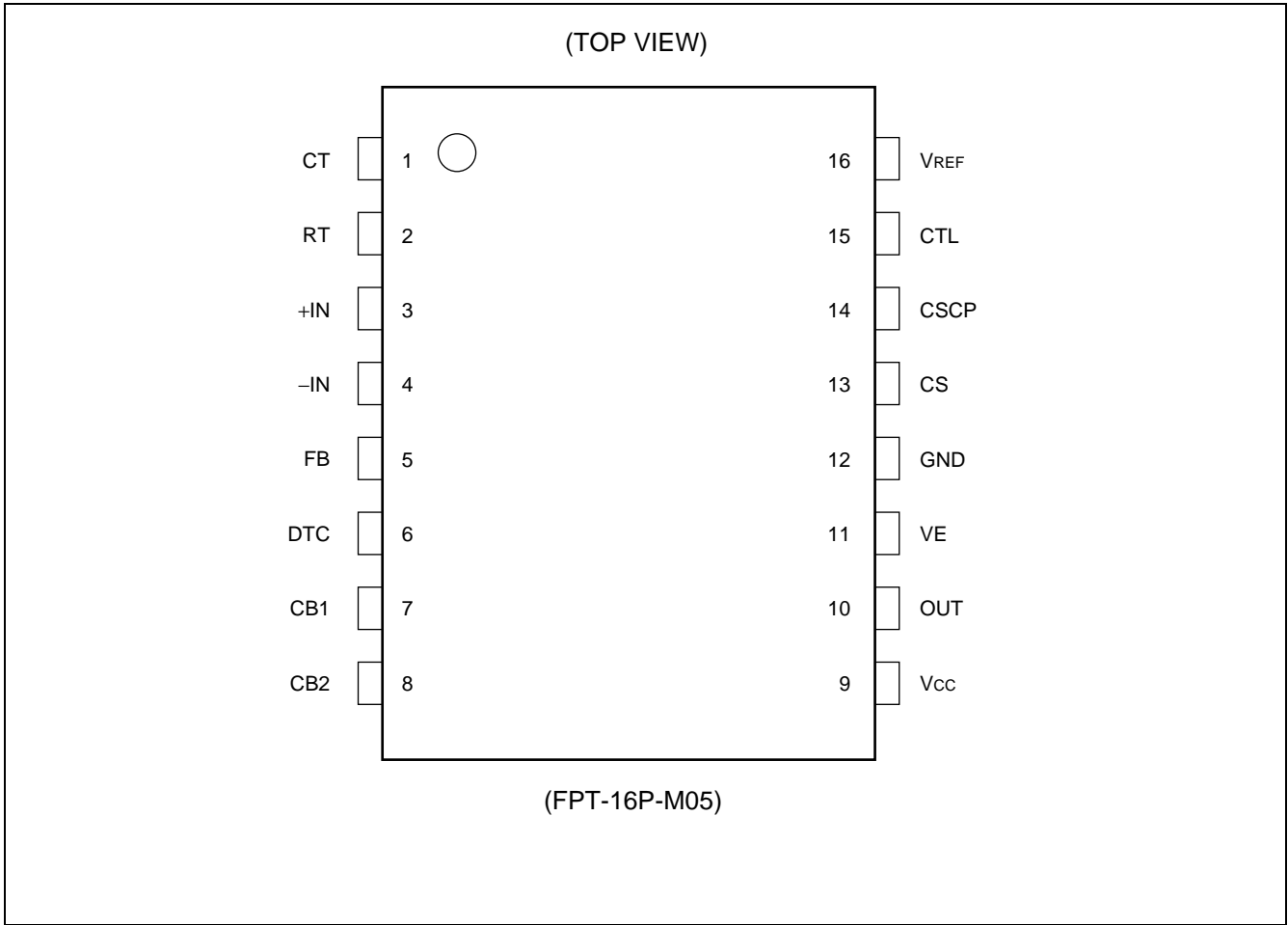

## ■ PIN DESCRIPTION

Pin no.	Pin name	I/O	Descriptions
1	CT	—	This terminal connects to a capacitor for setting the triangular-wave frequency.
2	RT	—	This terminal connects to a resistor for setting the triangular-wave frequency.
3	+IN	I	Error amplifier non-inverted input terminal
4	-IN	I	Error amplifier inverted input terminal
5	FB	O	Error amplifier output terminal
6	DTC	I	Dead time control terminal
7	CB1	—	Boot capacitor connection terminal
8	CB2	—	Boot capacitor connection terminal
9	V <sub>CC</sub>	—	Power supply terminal
10	OUT	O	Totem-pole type output terminal
11	VE	—	Output current setting terminal
12	GND	—	Ground terminal
13	CS	—	Soft start setting capacitor connection terminal
14	CSCP	—	Short detection setting capacitor connection terminal
15	CTL	I	Power supply control terminal When this terminal is High, IC is inactive state When this terminal is Low, IC is standby state
16	V <sub>REF</sub>	O	Reference voltage output terminal

# MB3817

## ■ BLOCK DIAGRAM

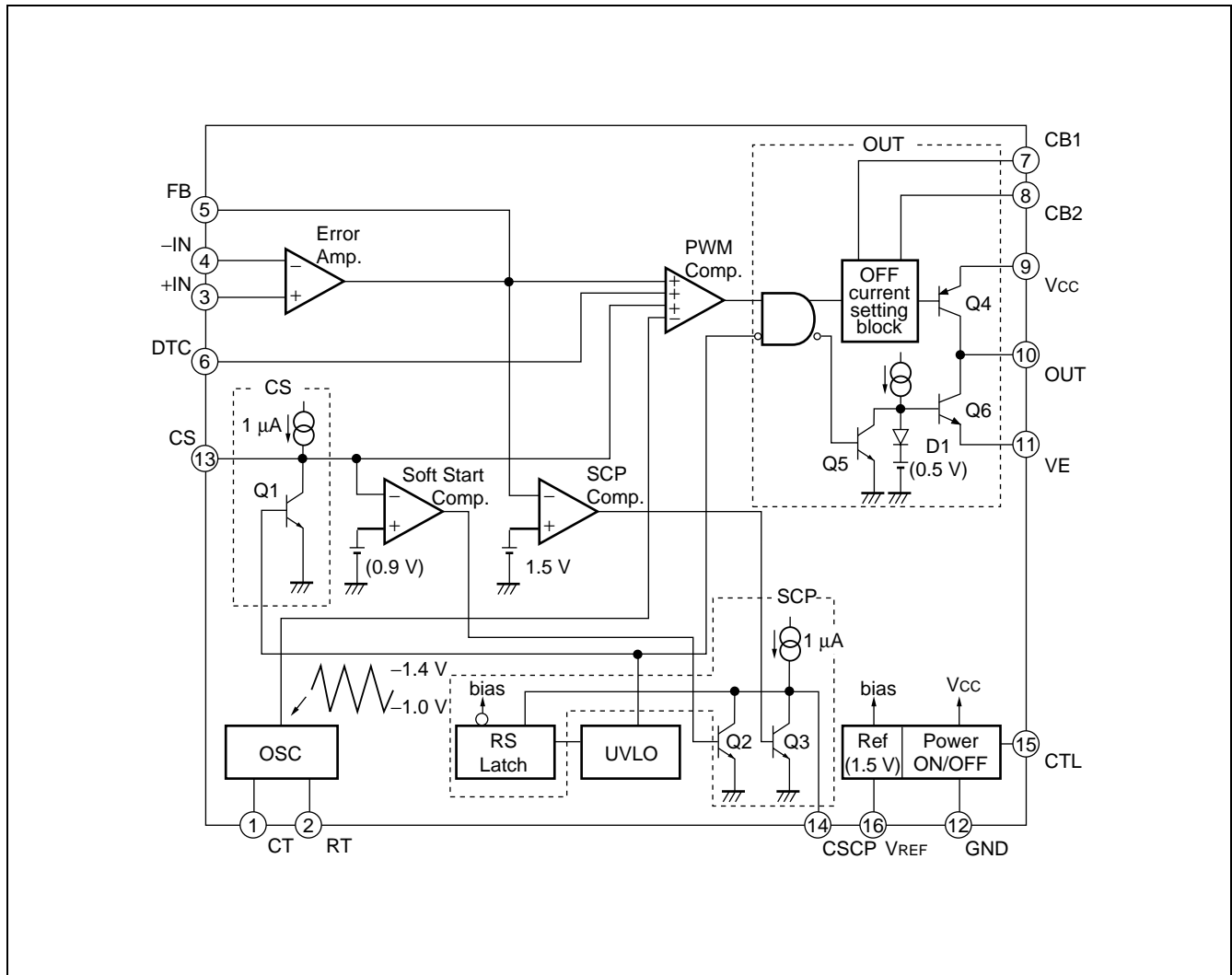

## ■ ABSOLUTE MAXIMUM RATINGS

Parameter	Symbol	Condition	Rating		Unit
			Min	Max	
Power supply voltage	V <sub>CC</sub>	—	—	20	V
Power dissipation	P <sub>D</sub>	T <sub>a</sub> ≤ +25 °C	—	440*	mW
Storage temperature	T <sub>stg</sub>	—	-55	+125	°C

\* : The package is mounted on the epoxy board (10 cm × 10 cm) .

WARNING: Semiconductor devices can be permanently damaged by application of stress (voltage, current, temperature, etc.) in excess of absolute maximum ratings. Do not exceed these ratings.

## ■ RECOMMENDED OPERATING CONDITIONS

Parameter	Symbol	Condition	Value			Unit
			Min	Typ	Max	
Power supply voltage	V <sub>CC</sub>	—	2.5	6.0	18	V
Reference voltage output current	I <sub>OR</sub>	—	-1	—	0	mA
Error amp. input voltage	V <sub>IN</sub>	—	0	—	V <sub>CC</sub> - 0.9	V
Control input voltage	V <sub>CTL</sub>	—	0	—	18	V
Output current	I <sub>O</sub>	—	3	—	30	mA
Timing capacitance	C <sub>T</sub>	—	150	—	1500	pF
Timing resistance	R <sub>T</sub>	—	5.1	—	100	kΩ
Oscillation frequency	f <sub>OSC</sub>	—	10	200	500	kHz
Soft start capacitance	C <sub>S</sub>	—	—	0.1	1.0	μF
Short detection capacitance	C <sub>SCP</sub>	—	—	0.1	1.0	μF
Boot capacitance	C <sub>B</sub>	—	—	—	0.1	μF
Operating temperature	T <sub>a</sub>	—	-40	+25	+85	°C

WARNING: The recommended operating conditions are required in order to ensure the normal operation of the semiconductor device. All of the device's electrical characteristics are warranted when the device is operated within these ranges.

Always use semiconductor devices within their recommended operating condition ranges. Operation outside these ranges may adversely affect reliability and could result in device failure.

No warranty is made with respect to uses, operating conditions, or combinations not represented on the data sheet. Users considering application outside the listed conditions are advised to contact their representatives beforehand.

# MB3817

## ■ ELECTRICAL CHARACTERISTICS

( $V_{CC} = 6\text{ V}$ ,  $T_a = +25\text{ }^\circ\text{C}$ )

Parameter		Symbol	Pin no.	Condition	Value			Unit
					Min	Typ	Max	
Reference section (Ref)	Output voltage	$V_{REF}$	16	—	1.47	1.50	1.53	V
	Output temperature stability	$\Delta V_{REF}/V_{REF}$	16	$T_a = -40^\circ\text{C}$ to $+85^\circ\text{C}$	—	0.5*	—	%
	Input stability	Line	16	$V_{CC} = 2.5\text{ V}$ to $18\text{ V}$	—	2	10	mV
	Load stability	Load	16	$I_{OR} = 0\text{ mA}$ to $-1\text{ mA}$	—	2	10	mV
	Short circuit output current	$I_{OS}$	16	$V_{REF} = 1\text{ V}$	-10	-5	-2	mA
Under voltage lockout protection section (UVLO)	Threshold voltage	$V_{TH}$	13	$V_{CC} = \overline{\text{L}}$	—	2.0	2.3	V
		$V_{TL}$	13	$V_{CC} = \overline{\text{H}}$	1.5	1.8	—	V
	Hysteresis width	$V_H$	13	—	0.1	0.2	—	V
	Reset voltage	$V_R$	13	—	0.6	1.0	—	V
Soft start section (CS)	Threshold voltage	$V_{T0}$	10	Duty cycle = 0%	0.9	1.0	—	V
		$V_{T100}$	10	Duty cycle = 100%	—	1.4	1.5	V
	Input standby voltage	$V_{STB}$	13	—	—	50	100	mV
	Charge current	$I_{CHG}$	13	—	-1.4	-1.0	-0.6	$\mu\text{A}$
Short circuit detection section (SCP)	Threshold voltage	$V_{TH}$	14	—	0.60	0.65	0.70	V
	Input standby voltage	$V_{STB}$	14	—	—	50	100	mV
	Input latch voltage	$V_I$	14	—	—	50	100	mV
	Input source current	$I_I$	14	—	-1.4	-1.0	-0.6	$\mu\text{A}$
Triangular waveform oscillator section (OSC)	Oscillator frequency	$f_{OSC}$	10	$C_T = 330\text{ pF}$ $R_T = 6.2\text{ k}\Omega$	450	500	550	kHz
	Frequency voltage stability	$\Delta f/f_{dv}$	10	$V_{CC} = 3.6\text{ V}$ to $16\text{ V}$	—	1	10	%
	Frequency temperature stability	$\Delta f/f_{dt}$	10	$T_a = -40^\circ\text{C}$ to $+85^\circ\text{C}$	—	1*	—	%

\* : Standard design value.

(Continued)

(Continued)

( $V_{CC} = 6\text{ V}$ ,  $T_a = +25\text{ }^\circ\text{C}$ )

Parameter	Symbol	Pin no.	Condition	Value			Unit	
				Min	Typ	Max		
Error amp. section (Error Amp.)	Input offset voltage	$V_{IO}$	3, 4	$V_{FB} = 1.2\text{ V}$	—	—	10	mV
	Input offset current	$I_{IO}$	3, 4	$V_{FB} = 1.2\text{ V}$	—	—	100	nA
	Input bias current	$I_I$	3, 4	$V_{FB} = 1.2\text{ V}$	-200	-100	—	nA
	Common mode input voltage range	$V_{CM}$	3, 4	—	0	—	$V_{CC} - 0.9$	V
	Common mode rejection ratio	CMRR	5	DC	60	100	—	dB
	Voltage gain	$A_V$	5	DC	60	100	—	dB
	Frequency bandwidth	BW	5	$A_V = 0\text{ dB}$	—	800*	—	kHz
	Maximum output voltage width	$V_{OM}^+$	5	—	1.8	2.0	—	V
		$V_{OM}^-$	5	—	—	50	500	mV
	Output sink current	$I_{O}^+$	5	$V_{FB} = 1.2\text{ V}$	60	120	—	$\mu\text{A}$
Output source current	$I_{O}^-$	5	$V_{FB} = 1.2\text{ V}$	—	-2.0	-0.6	mA	
Dead time control section (DTC)	Threshold voltage	$V_{T0}$	10	Duty cycle = 0%	0.9	1.0	—	V
		$V_{T100}$	10	Duty cycle = 100%	—	1.4	1.5	V
	ON duty cycle	Dtr	10	$V_{DTC} = V_{REF} \times 0.88$ $C_T = 330\text{ pF}$ , $R_T = 6.2\text{ k}\Omega$	70	80	90	%
Input current	$I_{DTC}$	6	$V_{DTC} = 0\text{ V}$	-500	-250	—	nA	
PWM comparator section (PWM Comp.)	Threshold voltage	$V_{T0}$	10	Duty cycle = 0%	0.9	1.0	—	V
		$V_{T100}$	10	Duty cycle = 100%	—	1.4	1.5	V
	Input sink current	$I_I^+$	5	—	60	120	—	$\mu\text{A}$
	Input source current	$I_I^-$	5	—	—	-2.0	-0.6	mA
Output section (OUT)	Output sink current	$I_{O}^+$	10	$R_E = 15\text{ k}\Omega$	18	30	42	mA
	Output source current	$I_{O}^-$	10	Duty $\leq 5\%$	—	-100	-50	mA
	Standby leakage current	$I_{LO}$	10	$V_{CC} = 18\text{ V}$ , $V_O = 18\text{ V}$	—	—	10	$\mu\text{A}$
Control section (CTL)	Input on condition	$V_{ON}$	11	—	2.1	—	18	V
	Input off condition	$V_{OFF}$	11	—	0	—	0.7	V
Input current	$I_I$	15	$V_{CTL} = 5\text{ V}$	—	100	200	$\mu\text{A}$	
Standby current	$I_{CCS}$	9	$V_{CTL} = 0\text{ V}$	—	—	10	$\mu\text{A}$	
Power supply current	$I_{CC}$	9	Output "H"	—	2.7	4.0	mA	

\* : Standard design value.

## ■ TYPICAL CHARACTERISTICS

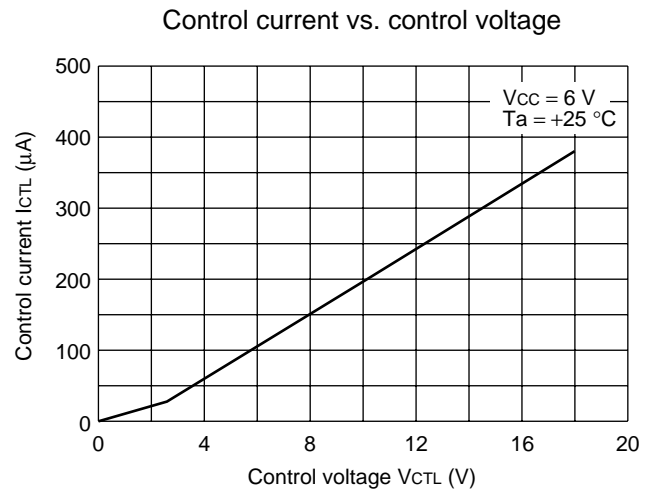
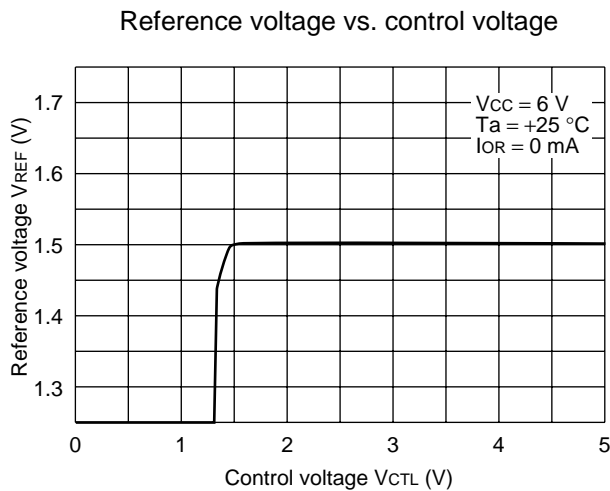
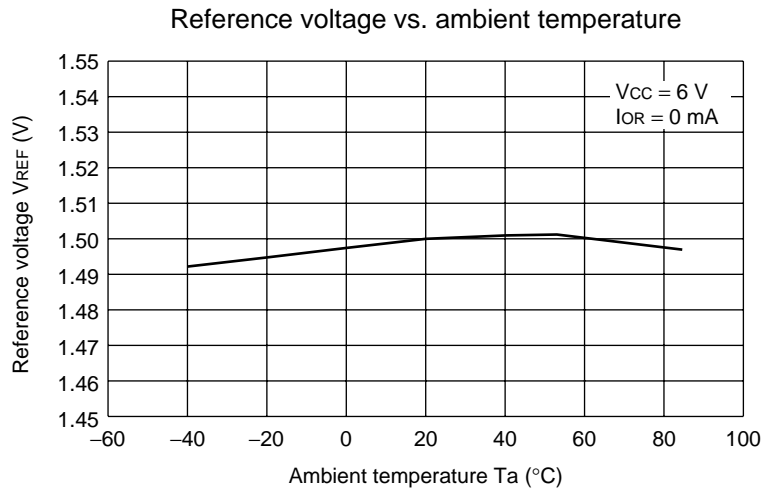
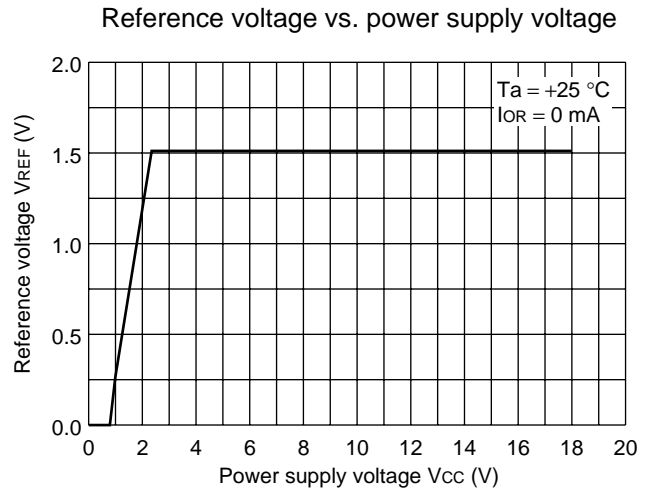
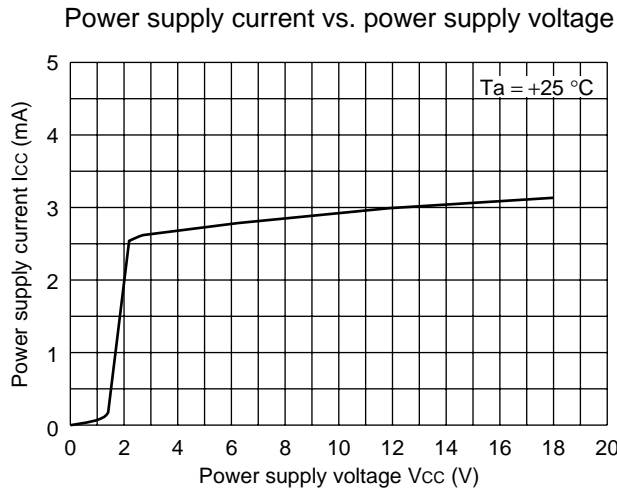

(Continued)



Triangular wave frequency vs. timing resistance

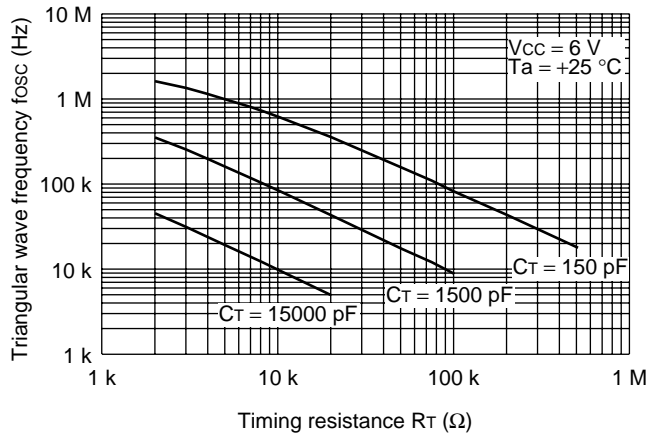

Triangular wave maximum amplitude voltage vs. timing capacitance

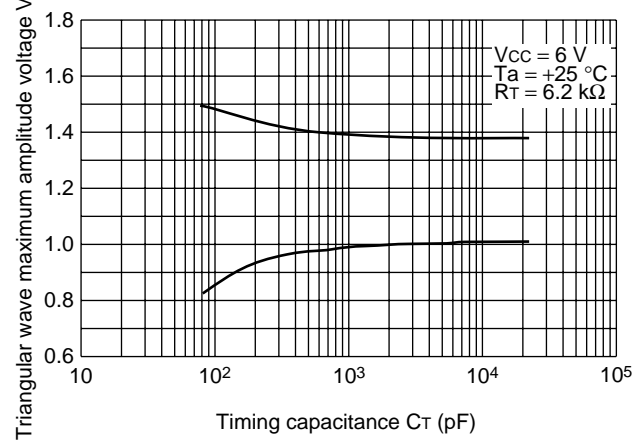

Duty vs. triangular wave frequency

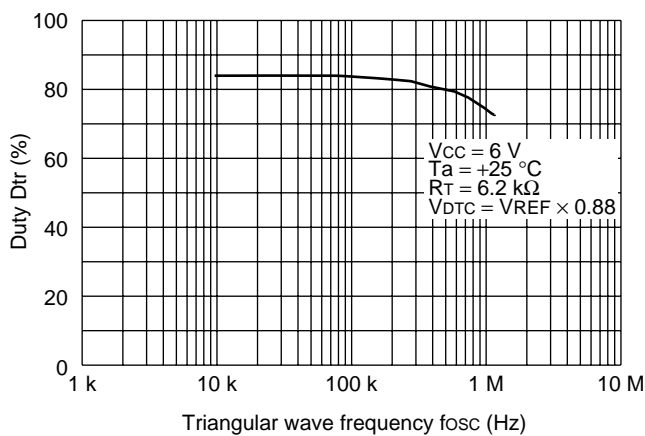

Triangular wave cycle vs. timing capacitance

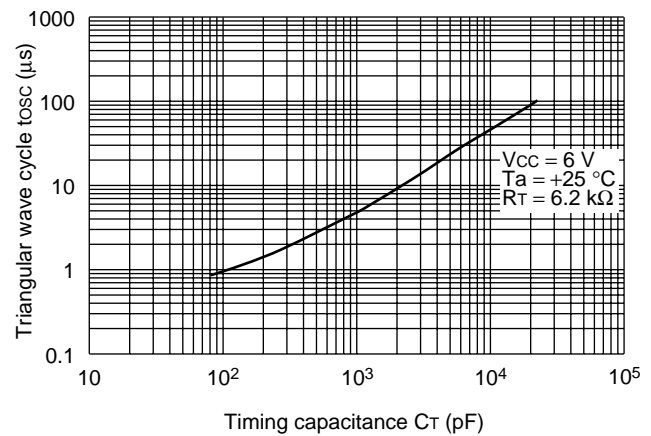

Frequency stability vs. ambient temperature

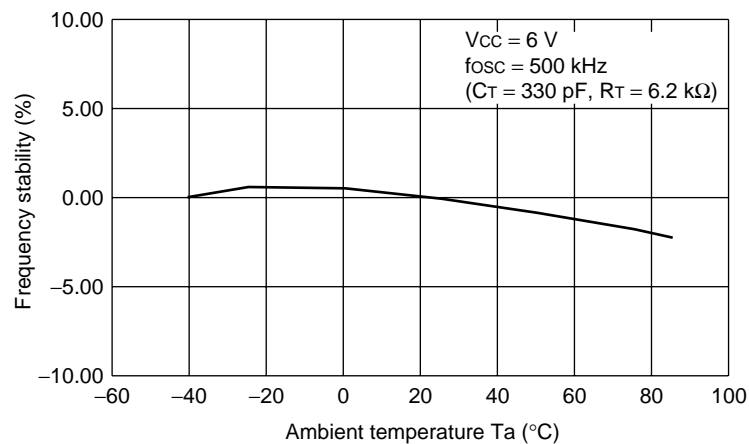

(Continued)

(Continued)

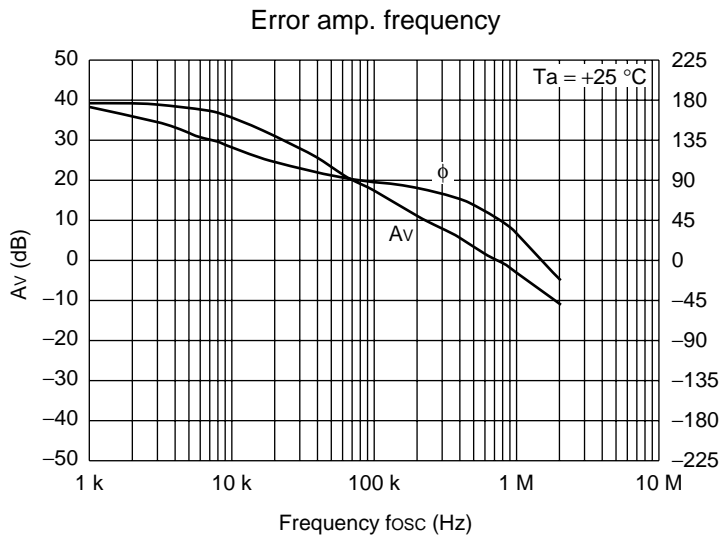

• Measurement circuit

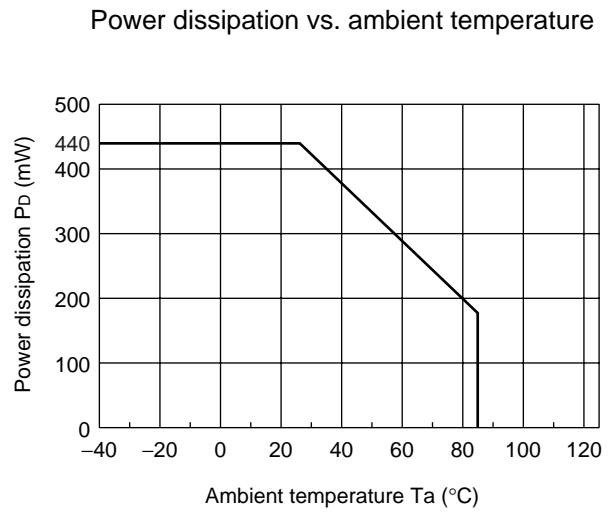
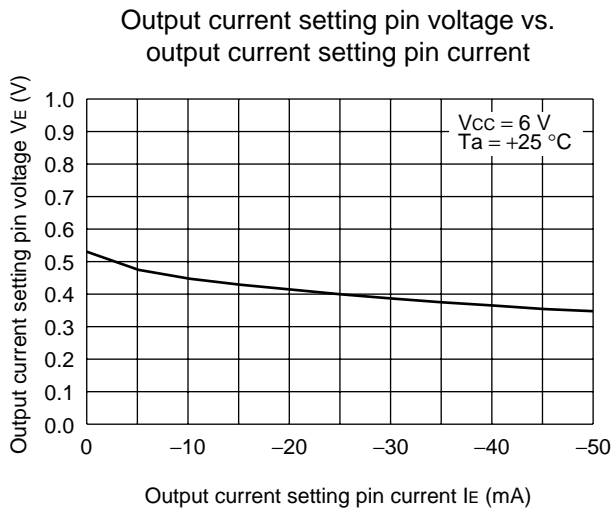
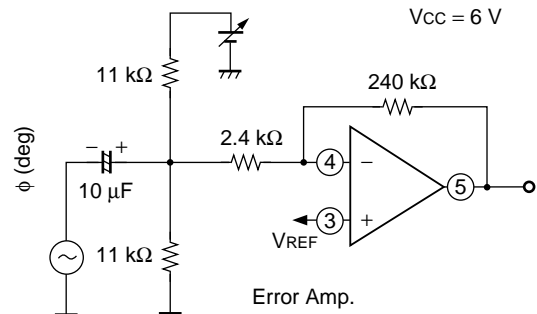

## ■ FUNCTIONAL DESCRIPTION

### 1. Switching Regulator Functions

#### (1) Reference voltage circuit (Ref)

The reference voltage circuit generates a temperature-compensated stable voltage ( $\approx 1.50\text{ V}$ ). This reference voltage is used as the reference voltage and bias level for the power control unit.

#### (2) Triangular-wave oscillator circuit

By connecting a timing capacitor and a resistor to the  $C_T$  (pin1) and the  $R_T$  (pin2) terminals, it is possible to generate any desired triangular oscillation waveform.

#### (3) Error amplifier

The error amp. is an amplifier circuit that detects the output voltage from the switching regulator and produces the PWM control signal. The broad in-phase input voltage range of 0 V to  $V_{CC} - 0.9\text{ V}$  provides easy setting from external power supplies and enables use with applications such as DC motor speed control systems.

Also, it is possible to provide stable phase compensation for a system by setting up any desired level of loop gain, by connecting feedback resistance and a capacitor between the error amp. output terminal (FB terminal (pin 5)) and the inverse input terminal ( $-IN$  terminal (pin 4)).

#### (4) PWM comparator (PWM Comp.)

This is a voltage comparator with one inverted input and three non-inverted inputs, and operates as a voltage-pulse width modulator controlling output duty in relation to input voltage.

The output transistor is turned on during the interval in which the triangular waveform is lower than any of three voltages: the error amp. output voltage (FB terminal (pin 5)), soft start set voltage (CS terminal (pin 13)), or dwell time setting voltage (DTC terminal (pin 6)).

#### (5) Output circuits (OUT)

The output circuit has totem pole type configuration, and can drive an external PNP transistor.

The on current value can be set up to a maximum of 30 mA using the resistance ( $R_E$ ) connected to the VE terminal (pin 11).

The off current is set by connecting a bootstrap capacitor  $C_B$  between the CP1 terminal (pin 7) and CP2 terminal (pin 8).

### 2. Power Supply Control Functions

The output is switched on and off according to the voltage level at the CTL terminal (pin 15).

CTL terminal voltage level	Channel on/off status
L ( $\leq 0.7\text{ V}$ )	Standby mode*
H ( $\geq 2.1\text{ V}$ )	Operating mode

\* : Supply current in standby mode is 10  $\mu\text{A}$  or less.

### 3. Protective Circuit Functions

#### (1) Soft start and short protection circuits (CS, SCP)

Soft starting, by preventing a rush current at power-on, can be provided by connecting a capacitor  $C_s$  to the CS terminal (pin 13) .

After the soft start operation is completed, the CSCP terminal (pin 14) is held at "L" level (standby voltage  $V_{STB}$ ), which functions as short detection standby mode. If an output short causes the error amp. output to rise above 1.5 V, capacitor  $C_{SCP}$  begins charging, and after reaching threshold voltage  $V_{TH}$  of 0.65 V causes the OUT terminal (pin 10) to be fixed at "H" level and the dwell time to be set to 100%, and the CSCP terminal (pin 14) is held at "L" level.

Once the protection circuit has been activated, the power supply must be reset to restore operation.

#### (2) Low input voltage error prevention circuit (UVLO)

Power-on surges and momentary drops in power supply voltage can cause errors in control IC operation, which can destroy or damage systems. The low input voltage error protection circuit compares the supply voltage to the internal reference voltage, and sets the OUT terminal (pin 10) to "H" level in the event of a drop in supply voltage.

Operation is restored when the power supply voltage returns above the threshold voltage of the low input voltage error prevention circuit.

## ■ SETTING OUTPUT VOLTAGE

- Output voltage  $V_o$  is plus

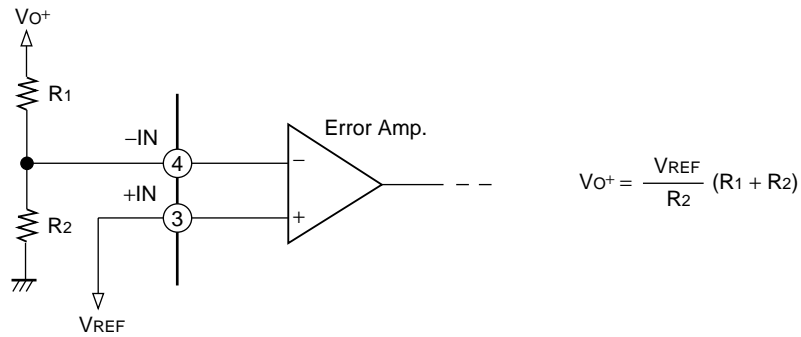

- Output voltage  $V_o$  is minus

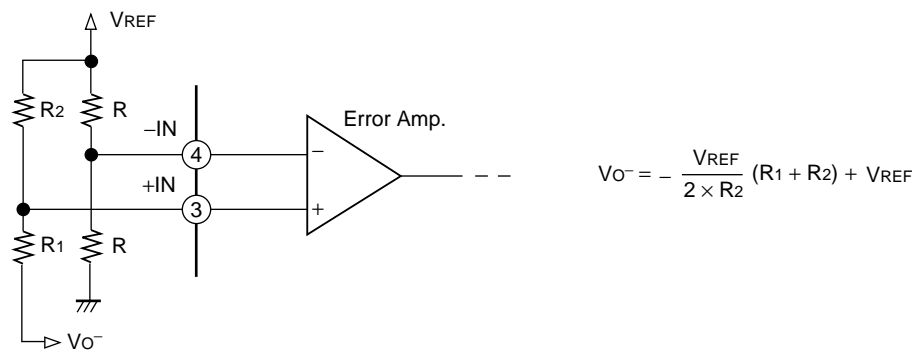

## ■ OSCILATOR FREQUENCY SETTING

The oscillator frequency can be set by connecting a timing capacitor ( $C_T$ ) to the CT terminal (pin1) and a timing resistor ( $R_T$ ) to the RT terminal (pin2) .

Oscillator frequency :  $f_{osc}$

$$f_{osc} \text{ (kHz)} \cong \frac{1023000}{C_T \text{ (pF)} \bullet R_T \text{ (k}\Omega\text{)}}$$

## ■ METHOD OF SETTING THE OUTPUT CURRENT

The output circuit is comprised of a totem-pole configuration. Its output current waveform is such that the ON-current value is set by constant current and the OFF-current value is set by a time constant. These output currents are set using the equations below.

$$\text{ON current : } I_{o+} [\text{mA}] \approx \frac{500}{R_E [\Omega]} \quad (\text{Voltage on output current-setting pin } V_E = 0.5 \text{ V})$$

OFF current : OFF-current time constant = proportional to the value of  $C_B$

### • Output circuit

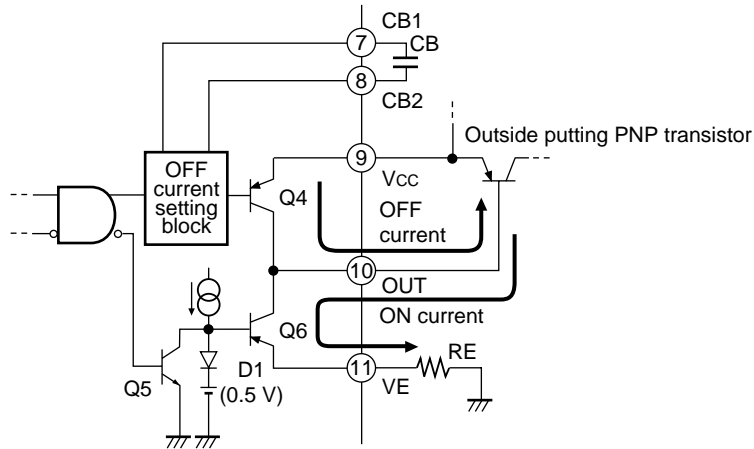

### • Output current waveform

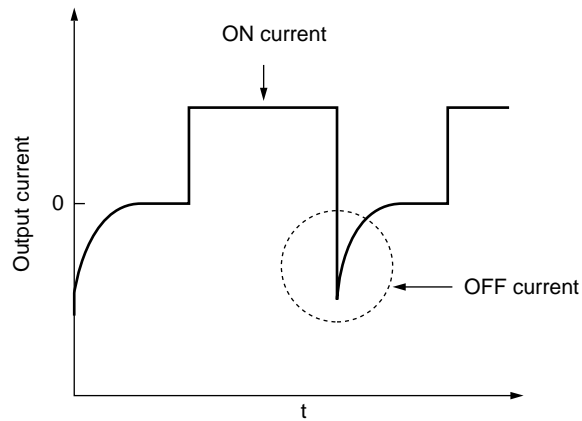

• Voltage and current waveforms on output terminal

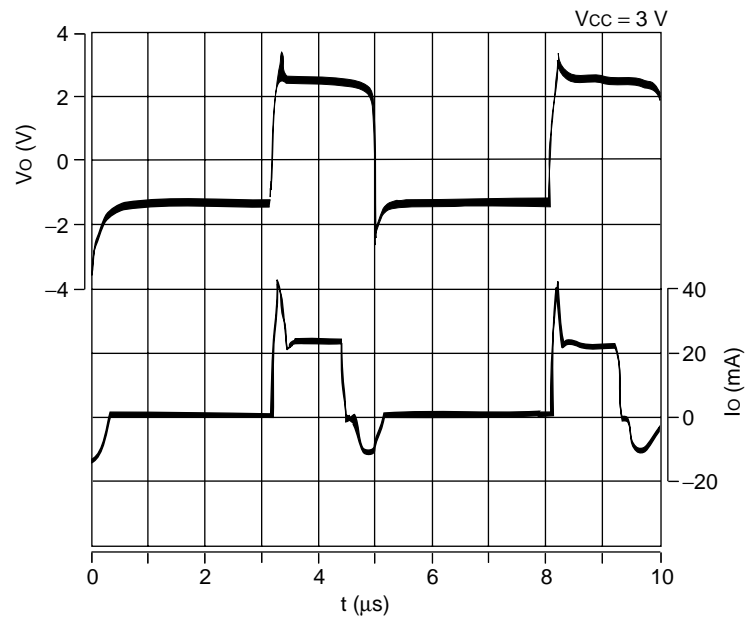

• Measuring circuit diagram

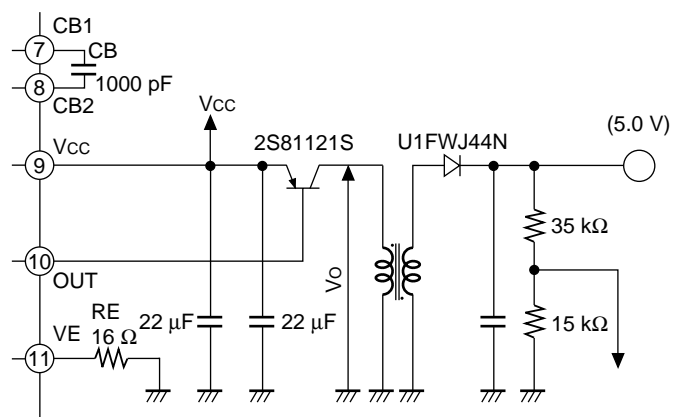





## ■ TREATMENT WHEN NOT USING CSCP

When you do not use the timer/latch-actuated short-circuiting protection circuit, connect the CSCP terminal (pin 14) to GND.

- Treatment when not using CSCP

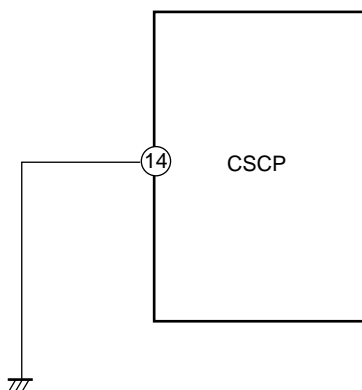

## ■ METHOD OF SETTING SOFT START TIME

To protect against surge currents when the IC is turned on, a soft start setting can be made by connecting a soft start capacitor ( $C_s$ ) to the CS terminal (pin 13) .

When the IC starts up (CTL terminal (pin 15) to "H" level,  $V_{CC} \geq UVLO$  threshold voltage  $V_{TH}$ ) the transistor Q1 turns off and the soft start capacitor ( $C_s$ ) connected to the CS terminal begins charging from the charge current  $I_{CHG}$  which is  $-1.0 \mu A$ .

At this time, if the CS terminal voltage is less than 0.9 V, the soft start comparator circuit output goes to "H" level, transistor Q2 turns on and the CSCP terminal (pin 14) holds input standby voltage  $V_{STB}$  which is 50 mV so that the short protection circuit is not activated. When the CS terminal voltage is greater than or equal to 0.9 V, transistor Q2 turns off, the PWM comparator circuit compares the CS terminal voltage with the triangular wave and changes the ON duty of the OUTPUT terminal, thus achieving a soft start. Note that the soft start time is determined by the following formula.

Soft start time (time before output ON duty reaches 50%)

$$t_s [\text{ms}] \approx 1.2 \times C_s [\mu\text{F}]$$

### • Soft start circuit

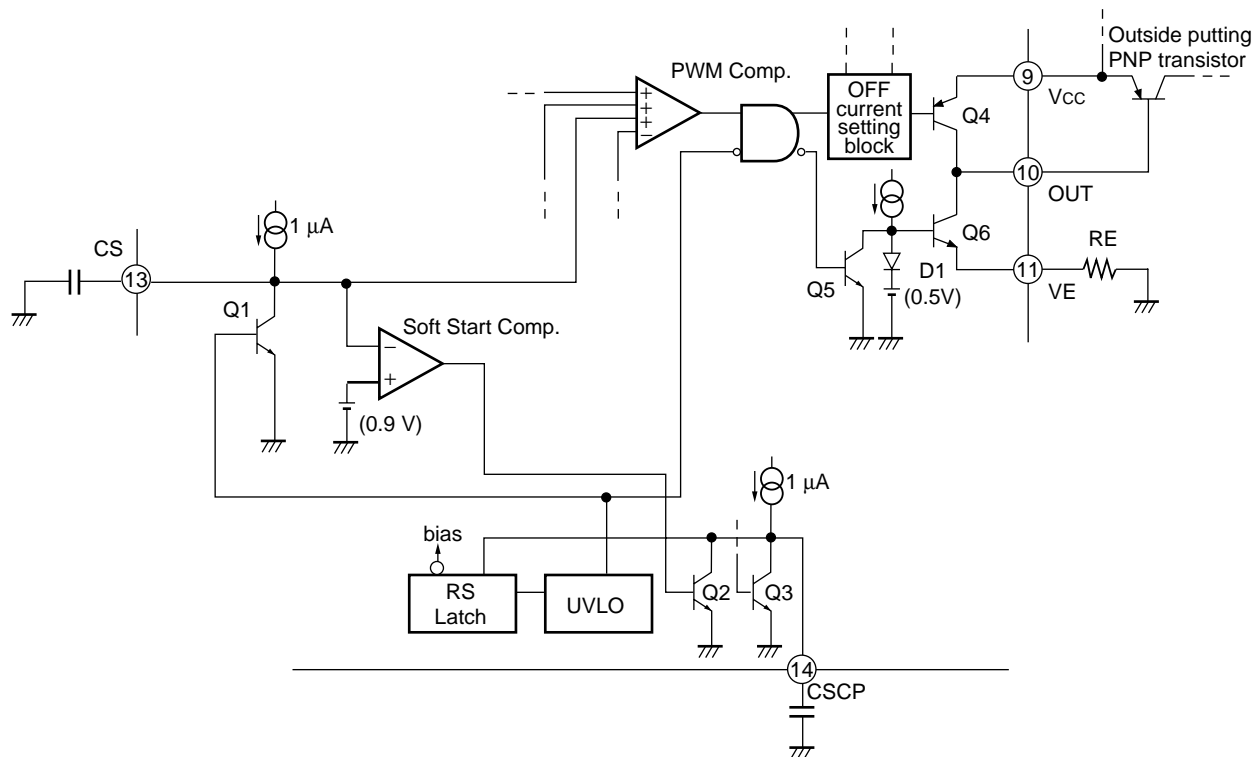

**■ TREATMENT WHEN NOT USING CS**

When not using the soft start function, the CS terminal (pin 13) should be left open.

- When no soft start time is set

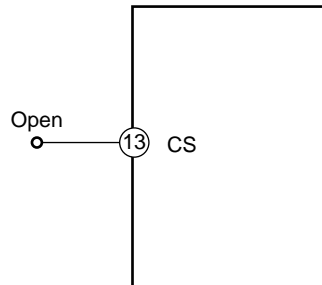

## ■ METHOD OF SETTING THE DEAD TIME

When the device is set for step-up inverted output based on the flyback method, the output transistor is fixed to a full-on state (ON-duty = 100%) at power switch-on. To prevent this problem, you may determine the voltages on the DTC terminals (pin 6) from the  $V_{REF}$  voltage so you can easily set the output transistor's dead time (maximum ON-duty) independently for each channel as shown below.

When the voltage on the DTC terminals (pin 6) is lower than the triangular-wave output voltage from the oscillator, the output transistor turns off. The dead time calculation formula assuming that triangular-wave amplitude  $\cong 0.4$  V and triangular-wave minimum voltage  $\cong 1.4$  V is given below.

$$\text{Duty (ON)}_{\text{MAX}} \cong \frac{V_{dt} - 1.0 \text{ V}}{0.4} \times 100 [\%]$$

When you do not use these DTC terminals, connect them to  $V_{REF}$  terminal.

### • When using DTC to set dead time

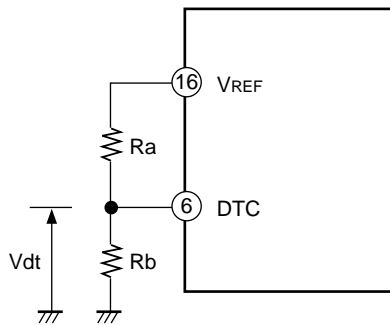

### • When not using DTC to set dead time

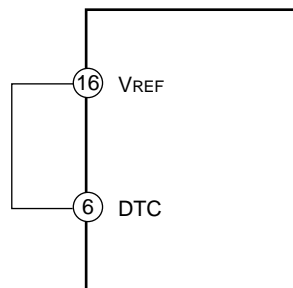

APPLICATION EXAMPLE

1. Step-down scheme

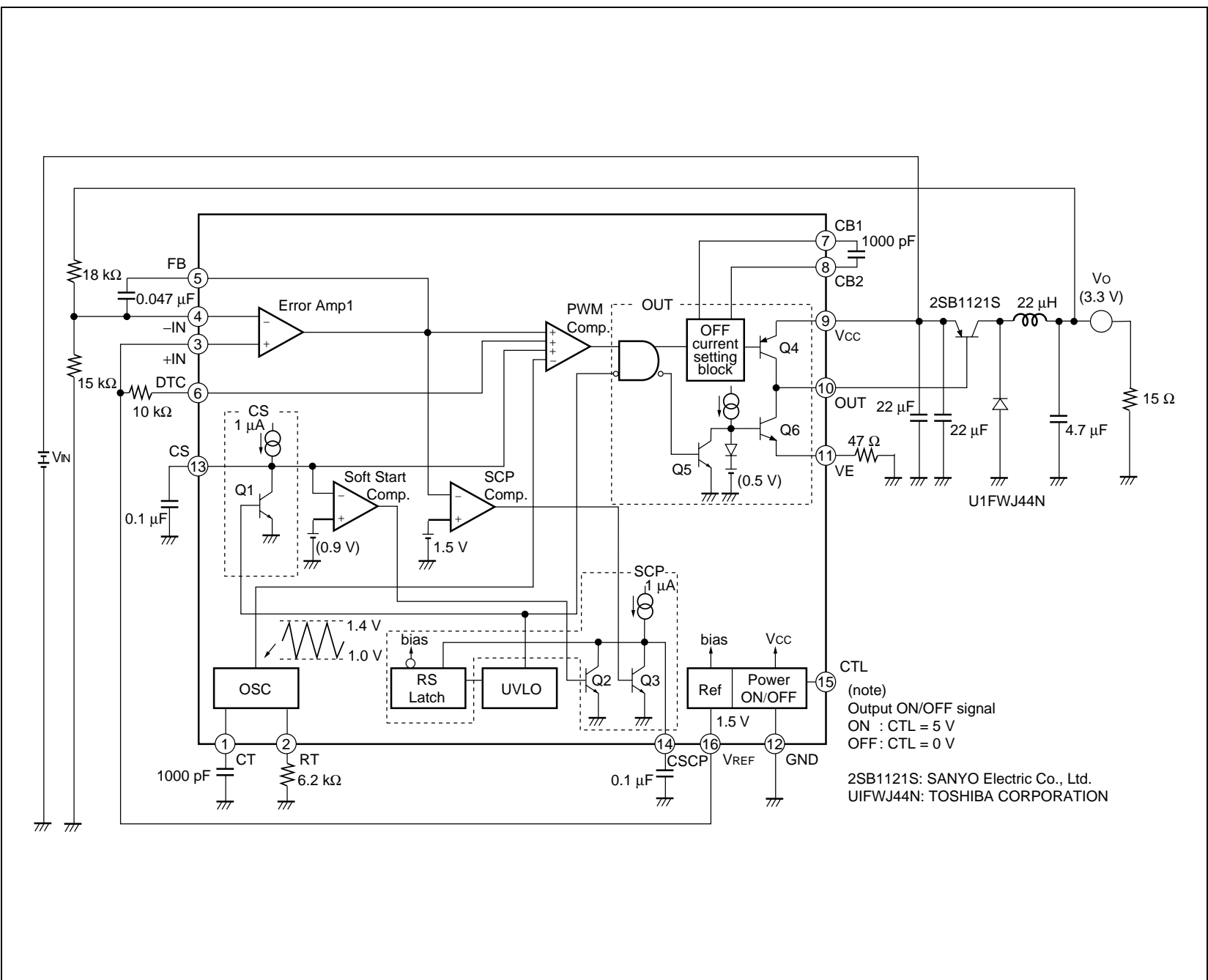

2. Zeta scheme

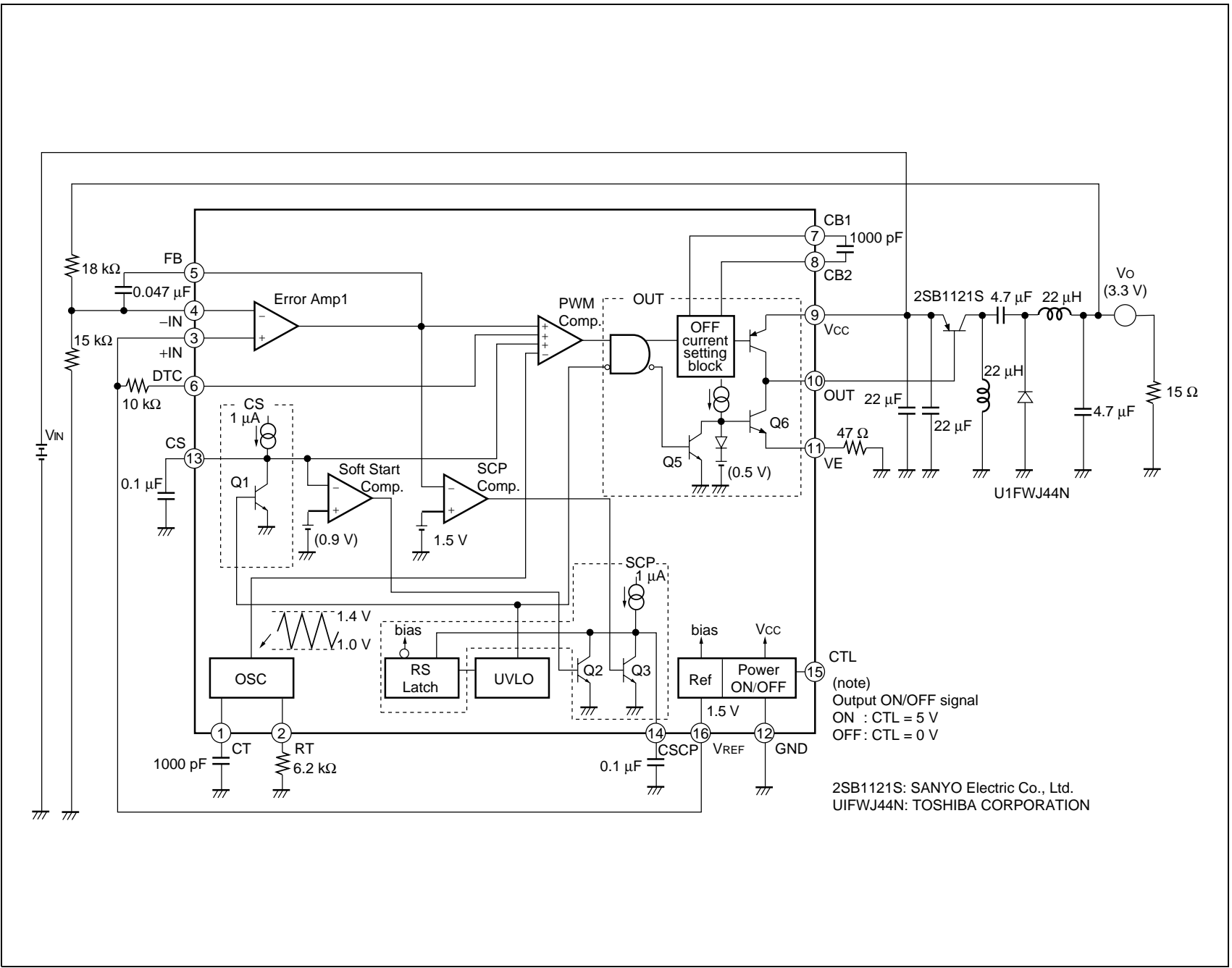

2SB1121S: SANYO Electric Co., Ltd.  
U1FWJ44N: TOSHIBA CORPORATION



## ■ APPLICATION

### 1. Equivalent series resistance and stability of smoothing capacitor

The equivalent series resistance (ESR) of the smoothing capacitor in the DC/DC converter greatly affects the loop phase characteristic.

A smoothing capacitor with a high ESR improves system stability because the phase is advanced into the high-frequency range of an ideal capacitor (see Fig. 34 and 35). A smoothing capacitor with a low ESR reduces system stability. Use care when using low ESR electrolytic capacitors (OS-CON™) and tantalum capacitors.

Note : OS-CON is the trademark of Sanyo Electric Co.,Ltd.

**Figure 33 DC/DC Converter Basic Circuit**

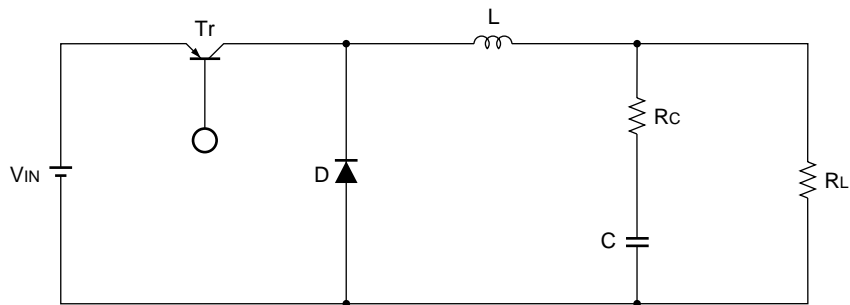

**Figure 34 Gain vs. Frequency**

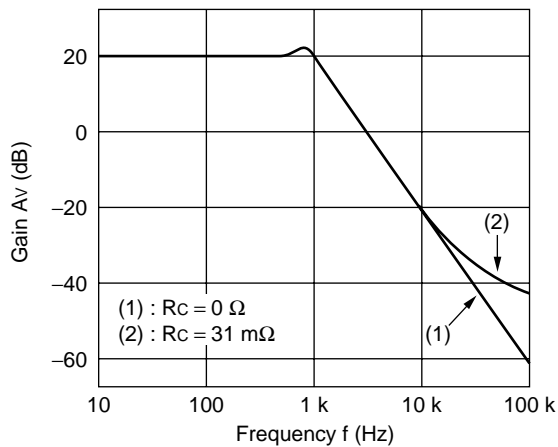

**Figure 35 Phase vs. Frequency**

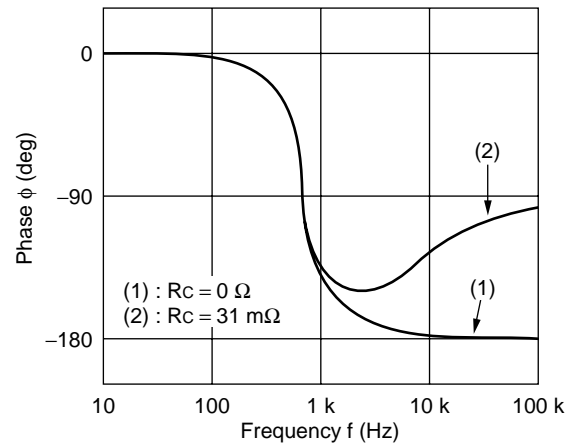



## Reference data

In an aluminum electrolytic smoothing capacitor ( $RC \approx 1.0 \Omega$ ) is replaced with a low ESR electrolytic capacitor (OS-CON™ :  $RC \approx 0.2 \Omega$ ), the phase margin is reduced by half (see Fig. 37 and 38).

**Figure 36 DC/DC Converter  $A_v$  vs.  $\phi$  characteristic Test Circuit**

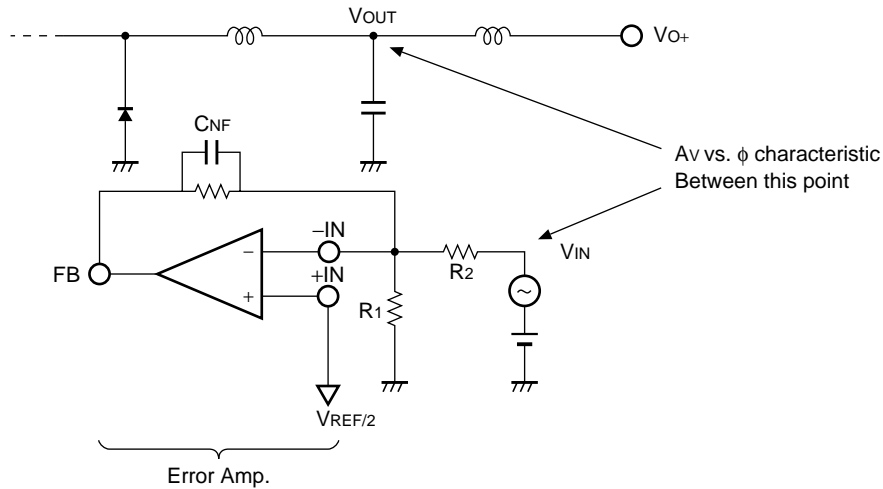

**Figure 37 DC/DC Converter +5 V output Gain vs. Phase**

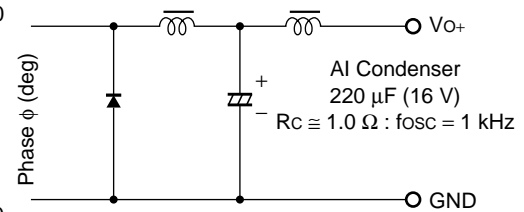
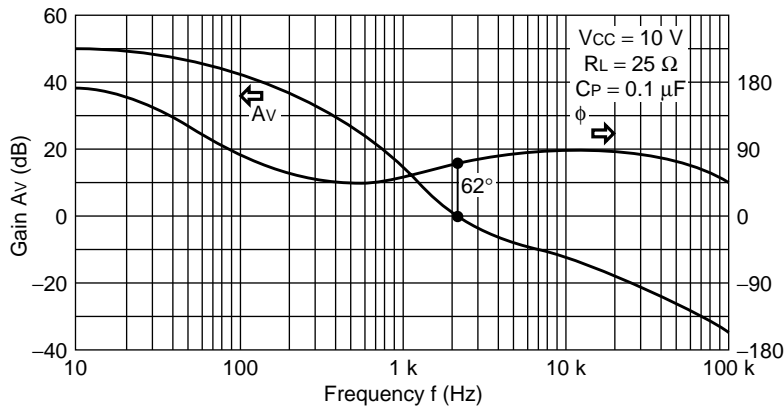

**Figure 38 DC/DC Converter +5 V output Gain vs. Phase**

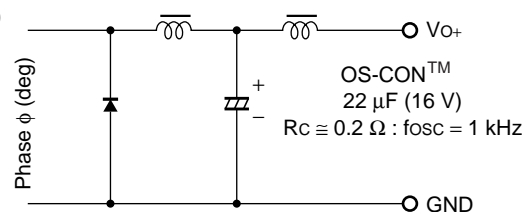
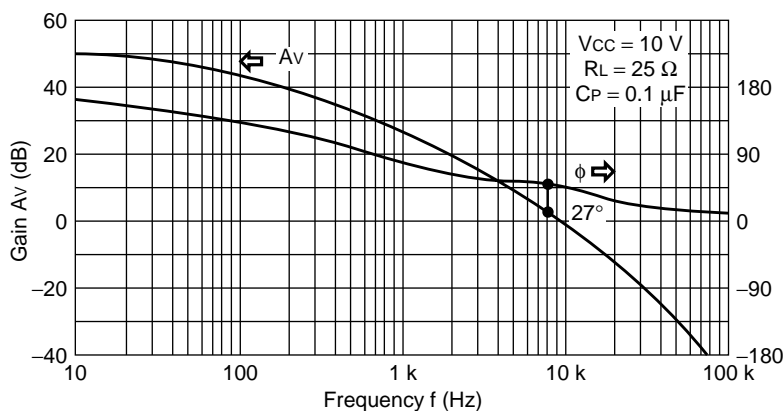

# MB3817

## ■ NOTES ON USE

- Take account of common impedance when designing the earth line on a printed wiring board.
- Take measures against static electricity.
  - For semiconductors, use antistatic or conductive containers.
  - When storing or carrying a printed circuit board after chip mounting, put it in a conductive bag or container.
  - The work table, tools and measuring instruments must be grounded.
  - The worker must put on a grounding device containing 250 k $\Omega$  to 1 M $\Omega$  resistors in series.
- Do not apply a negative voltage
  - Applying a negative voltage of  $-0.3$  V or less to an LSI may generate a parasitic transistor, resulting in malfunction.

## ■ ORDERING INFORMATION

Part number	Package	Remarks
MB3817PFV	16-pin Plastic SSOP (FPT-16P-M05)	

## ■ PACKAGE DIMENSION

16-pin Plastic SSOP  
(FPT-16P-M05)

Note 1) \*1 : Resin protrusion. (Each side : +0.15 (.006) Max) .  
 Note 2) \*2 : These dimensions do not include resin protrusion.  
 Note 3) Pins width and pins thickness include plating thickness.  
 Note 4) Pins width do not include tie bar cutting remainder.

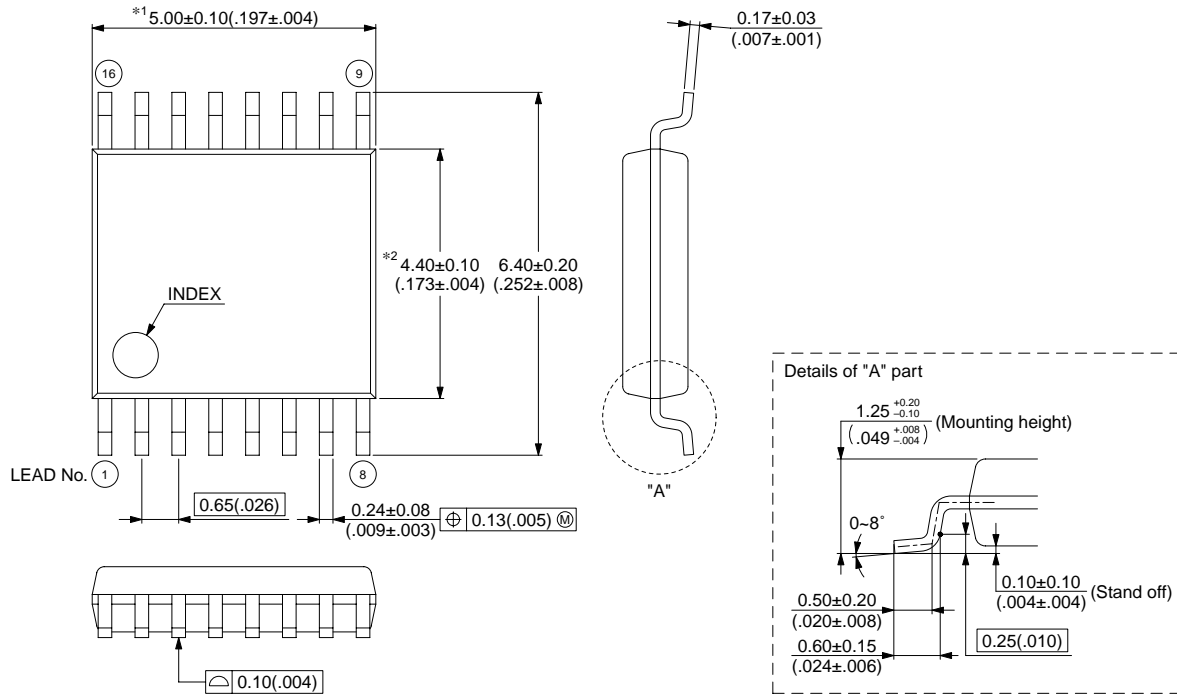

© 2003 FUJITSU LIMITED F16013S-c-4-6

Dimensions in mm (inches)

Note : The values in parentheses are reference values.

# FUJITSU MICROELECTRONICS LIMITED

Shinjuku Dai-Ichi Seimei Bldg. 7-1, Nishishinjuku 2-chome, Shinjuku-ku,  
Tokyo 163-0722, Japan Tel: +81-3-5322-3347 Fax: +81-3-5322-3387  
<http://jp.fujitsu.com/fml/en/>

*For further information please contact:*

## **North and South America**

FUJITSU MICROELECTRONICS AMERICA, INC.  
1250 E. Arques Avenue, M/S 333  
Sunnyvale, CA 94085-5401, U.S.A.  
Tel: +1-408-737-5600 Fax: +1-408-737-5999  
<http://www.fma.fujitsu.com/>

## **Europe**

FUJITSU MICROELECTRONICS EUROPE GmbH  
Pittlerstrasse 47, 63225 Langen,  
Germany  
Tel: +49-6103-690-0 Fax: +49-6103-690-122  
<http://emea.fujitsu.com/microelectronics/>

## **Korea**

FUJITSU MICROELECTRONICS KOREA LTD.  
206 KOSMO TOWER, 1002 Daechi-Dong,  
Kangnam-Gu, Seoul 135-280  
Korea  
Tel: +82-2-3484-7100 Fax: +82-2-3484-7111  
<http://www.fmk.fujitsu.com/>

## **Asia Pacific**

FUJITSU MICROELECTRONICS ASIA PTE LTD.  
151 Lorong Chuan, #05-08 New Tech Park,  
Singapore 556741  
Tel: +65-6281-0770 Fax: +65-6281-0220  
<http://www.fujitsu.com/sg/services/micro/semiconductor/>

FUJITSU MICROELECTRONICS SHANGHAI CO., LTD.  
Rm.3102, Bund Center, No.222 Yan An Road(E),  
Shanghai 200002, China  
Tel: +86-21-6335-1560 Fax: +86-21-6335-1605  
<http://cn.fujitsu.com/fmc/>

FUJITSU MICROELECTRONICS PACIFIC ASIA LTD.  
10/F., World Commerce Centre, 11 Canton Road  
Tsimshatsui, Kowloon  
Hong Kong  
Tel: +852-2377-0226 Fax: +852-2376-3269  
<http://cn.fujitsu.com/fmc/tw>

All Rights Reserved.

The contents of this document are subject to change without notice.

Customers are advised to consult with sales representatives before ordering.

The information, such as descriptions of function and application circuit examples, in this document are presented solely for the purpose of reference to show examples of operations and uses of FUJITSU MICROELECTRONICS device; FUJITSU MICROELECTRONICS does not warrant proper operation of the device with respect to use based on such information. When you develop equipment incorporating the device based on such information, you must assume any responsibility arising out of such use of the information.

FUJITSU MICROELECTRONICS assumes no liability for any damages whatsoever arising out of the use of the information.

Any information in this document, including descriptions of function and schematic diagrams, shall not be construed as license of the use or exercise of any intellectual property right, such as patent right or copyright, or any other right of FUJITSU MICROELECTRONICS or any third party or does FUJITSU MICROELECTRONICS warrant non-infringement of any third-party's intellectual property right or other right by using such information. FUJITSU MICROELECTRONICS assumes no liability for any infringement of the intellectual property rights or other rights of third parties which would result from the use of information contained herein.

The products described in this document are designed, developed and manufactured as contemplated for general use, including without limitation, ordinary industrial use, general office use, personal use, and household use, but are not designed, developed and manufactured as contemplated (1) for use accompanying fatal risks or dangers that, unless extremely high safety is secured, could have a serious effect to the public, and could lead directly to death, personal injury, severe physical damage or other loss (i.e., nuclear reaction control in nuclear facility, aircraft flight control, air traffic control, mass transport control, medical life support system, missile launch control in weapon system), or (2) for use requiring extremely high reliability (i.e., submersible repeater and artificial satellite).

Please note that FUJITSU MICROELECTRONICS will not be liable against you and/or any third party for any claims or damages arising in connection with above-mentioned uses of the products.

Any semiconductor devices have an inherent chance of failure. You must protect against injury, damage or loss from such failures by incorporating safety design measures into your facility and equipment such as redundancy, fire protection, and prevention of over-current levels and other abnormal operating conditions.

Exportation/release of any products described in this document may require necessary procedures in accordance with the regulations of the Foreign Exchange and Foreign Trade Control Law of Japan and/or US export control laws.

The company names and brand names herein are the trademarks or registered trademarks of their respective owners.