

Memory FRAM

64 K (8 K × 8) Bit SPI

MB85RS64V

■ DESCRIPTION

MB85RS64V is a FRAM (Ferroelectric Random Access Memory) chip in a configuration of 8,192 words × 8 bits, using the ferroelectric process and silicon gate CMOS process technologies for forming the nonvolatile memory cells.

MB85RS64V adopts the Serial Peripheral Interface (SPI).

The MB85RS64V is able to retain data without using a back-up battery, as is needed for SRAM.

The memory cells used in the MB85RS64V can be used for 10^{12} read/write operations, which is a significant improvement over the number of read and write operations supported by Flash memory and E²PROM.

MB85RS64V does not take long time to write data like Flash memories or E²PROM, and MB85RS64V takes no wait time.

■ FEATURES

- Bit configuration : 8,192 words × 8 bits
- Serial Peripheral Interface : SPI (Serial Peripheral Interface)
Correspondent to SPI mode 0 (0, 0) and mode 3 (1, 1)
- Operating frequency : 20 MHz (Max)
- High endurance : 10^{12} times / byte
- Data retention : 10 years (+ 85 °C), 95 years (+ 55 °C), over 200 years (+ 35 °C)
- Operating power supply voltage : 3.0 V to 5.5 V
- Low power consumption : Operating power supply current 1.5 mA (Typ@20 MHz)
Standby current 10 μA (Typ)
- Operation ambient temperature range : - 40 °C to +85 °C
- Package : 8-pin plastic SOP (FPT-8P-M02) RoHS compliant

■ PIN ASSIGNMENT

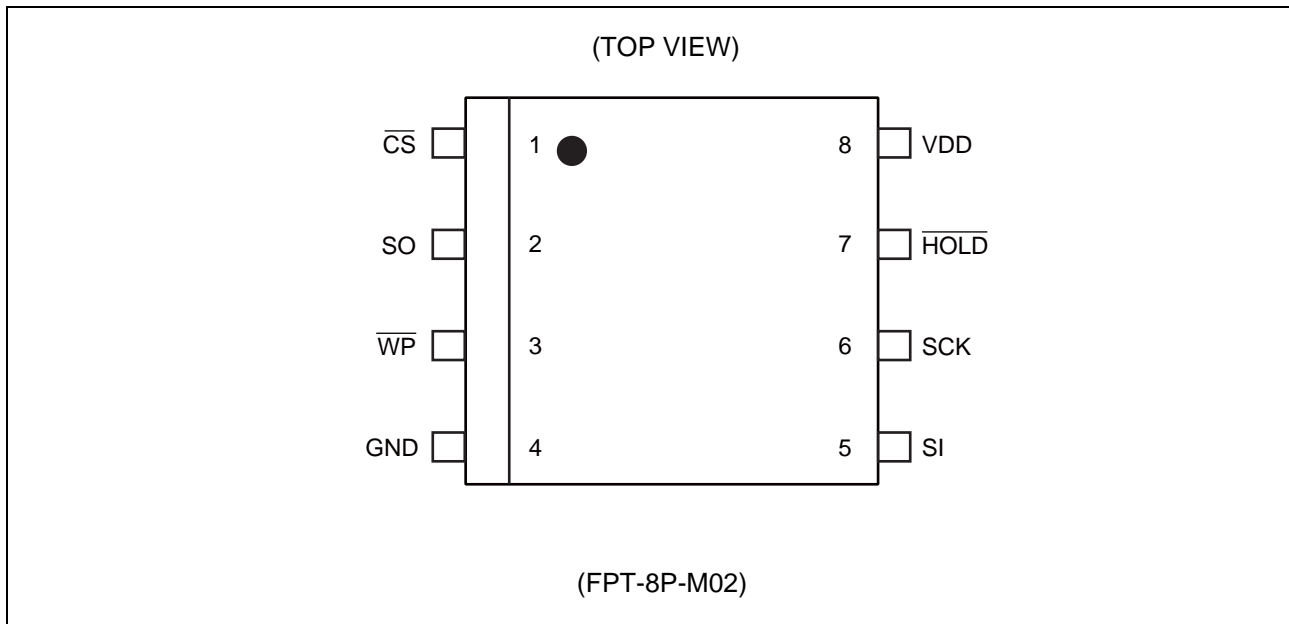

■ PIN FUNCTIONAL DESCRIPTIONS

Pin No.	Pin Name	Functional description
1	\overline{CS}	Chip Select pin This is an input pin to make chips select. When \overline{CS} is the "H" level, device is in deselect (standby) status and SO becomes High-Z. Inputs from other pins are ignored at this time. When \overline{CS} is the "L" level, device is in select (active) status. \overline{CS} has to be the "L" level before inputting op-code. The Chip Select pin is pulled up internally to the VDD pin.
3	\overline{WP}	Write Protect pin This is a pin to control writing to a status register. The writing of status register (see "■ STATUS REGISTER") is protected in related with \overline{WP} and WPEN. See "■ WRITING PROTECT" for detail.
7	\overline{HOLD}	Hold pin This pin is used to interrupt serial input/output without making chips deselect. When \overline{HOLD} is the "L" level, hold operation is activated, SO becomes High-Z, SCK and SI become don't care. While the hold operation, \overline{CS} has to be retained the "L" level.
6	SCK	Serial Clock pin This is a clock input pin to input/output serial data. SI is loaded synchronously to a rising edge, SO is output synchronously to a falling edge.
5	SI	Serial Data Input pin This is an input pin of serial data. This inputs op-code, address, and writing data.
2	SO	Serial Data Output pin This is an output pin of serial data. Reading data of FRAM memory cell array and status register data are output. This is High-Z during standby.
8	VDD	Supply Voltage pin
4	GND	Ground pin

■ BLOCK DIAGRAM

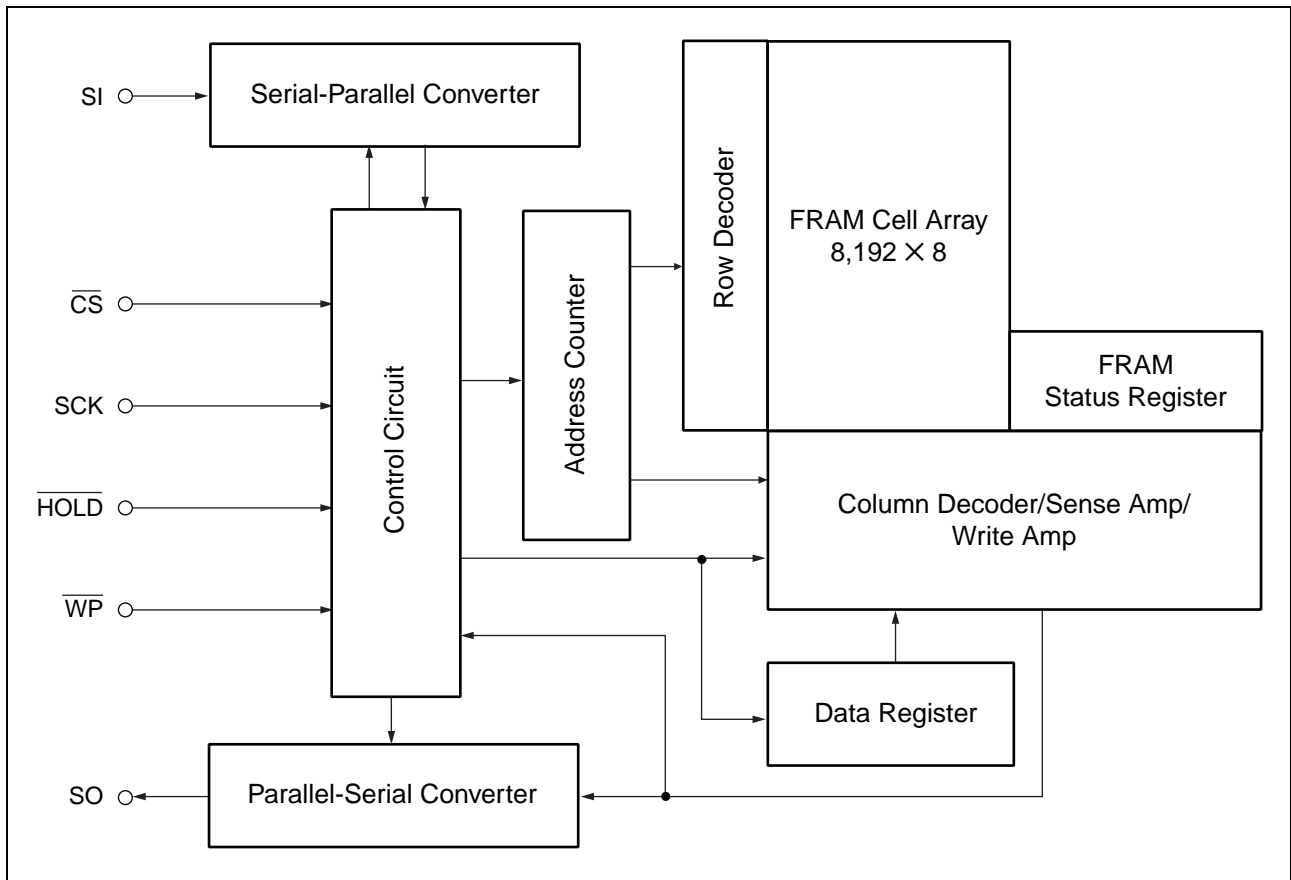

MB85RS64V

■ SPI MODE

MB85RS64V corresponds to the SPI mode 0 (CPOL = 0, CPHA = 0), and SPI mode 3 (CPOL = 1, CPHA = 1).

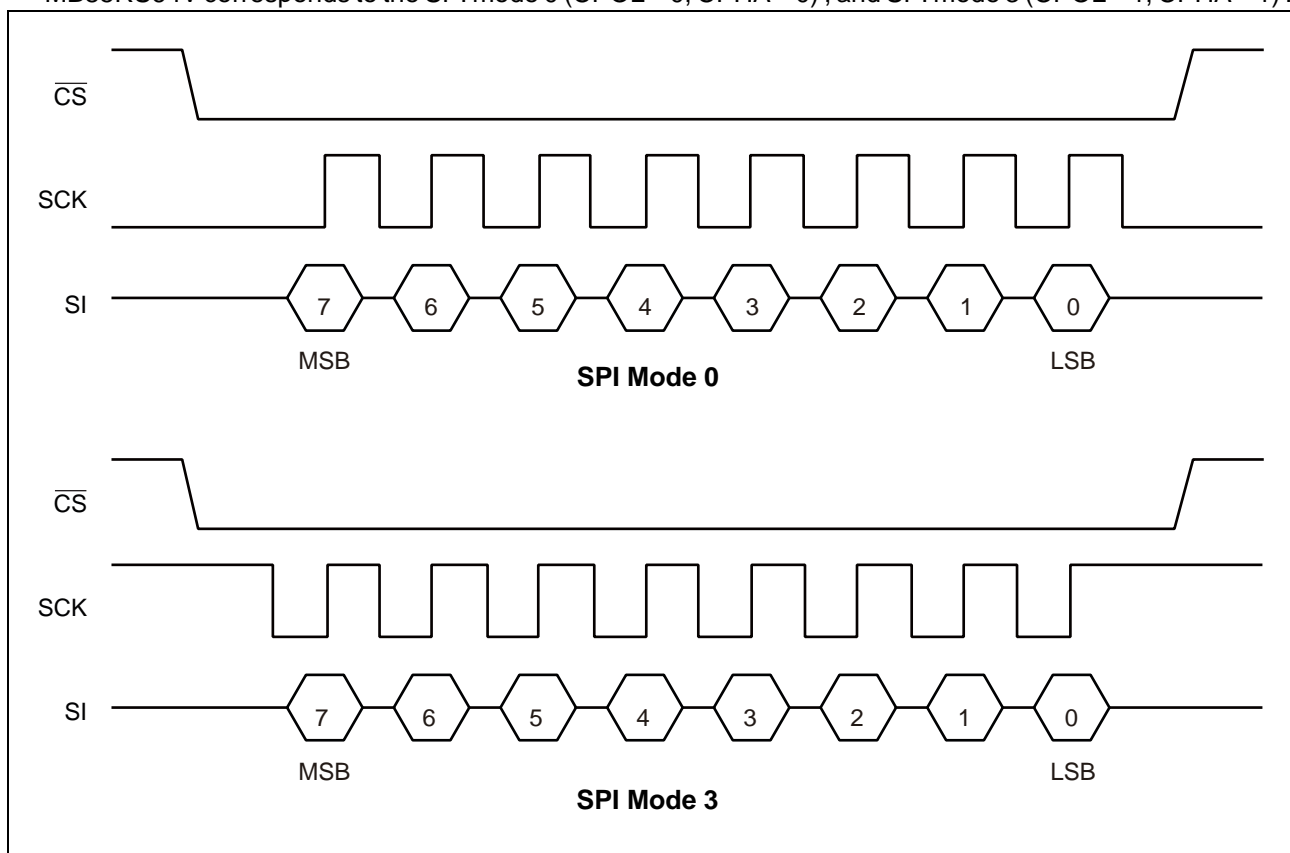

■ SERIAL PERIPHERAL INTERFACE (SPI)

MB85RS64V works as a slave of SPI. More than 2 devices can be connected by using microcontroller equipped with SPI port. By using a microcontroller not equipped with SPI port, SI and SO can be bus connected to use.

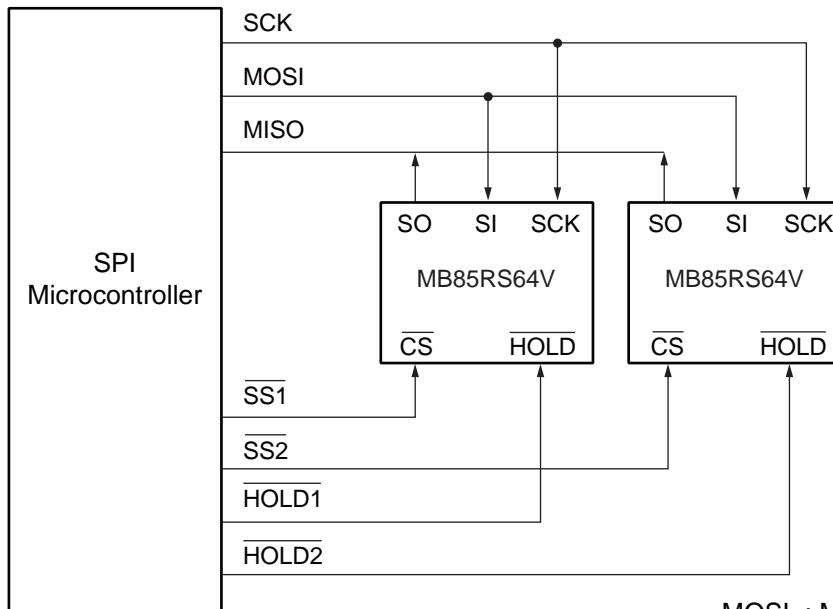

MOSI : Master Out Slave In
MISO : Master In Slave Out
SS : Slave Select

System Configuration with SPI Port

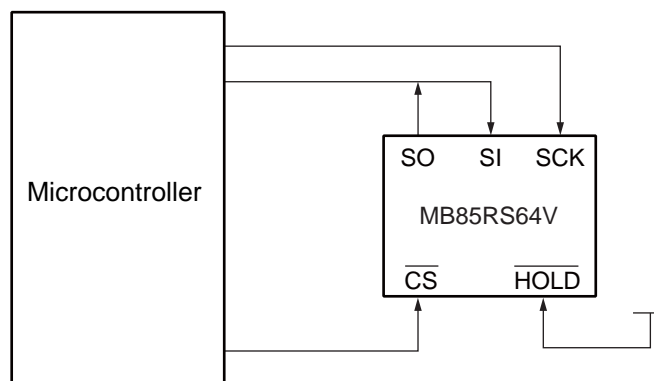

System Configuration without SPI Port

■ STATUS REGISTER

Bit No.	Bit Name	Function
7	WPEN	Status Register Write Protect This is a bit composed of nonvolatile memories (FRAM). WPEN protects writing to a status register (see “■ WRITING PROTECT”) relating with \overline{WP} input. Writing with the WRSR command and reading with the RDSR command are possible.
6 to 4	—	Not Used Bits These are bits composed of nonvolatile memories, writing with the WRSR command is possible. These bits are not used but they are read with the RDSR command.
3	BP1	Block Protect This is a bit composed of nonvolatile memory. This defines size of write protect block for the WRITE command (see “■ BLOCK PROTECT”). Writing with the WRSR command and reading with the RDSR command are possible.
2	BP0	
1	WEL	Write Enable Latch This indicates FRAM Array and status register are writable. The WREN command is for setting, and the WRDI command is for resetting. With the RDSR command, reading is possible but writing is not possible with the WRSR command. WEL is reset after the following operations. After power ON. After WRDI command recognition. The rising edge of \overline{CS} after WRSR command recognition. The rising edge of \overline{CS} after WRITE command recognition.
0	0	This is a bit fixed to “0”.

■ OP-CODE

MB85RS64V accepts 7 kinds of command specified in op-code. Op-code is a code composed of 8 bits shown in the table below. Do not input invalid codes other than those codes. If \overline{CS} is risen while inputting op-code, the command are not performed.

Name	Description	Op-code
WREN	Set Write Enable Latch	0000 0110 _B
WRDI	Reset Write Enable Latch	0000 0100 _B
RDSR	Read Status Register	0000 0101 _B
WRSR	Write Status Register	0000 0001 _B
READ	Read Memory Code	0000 0011 _B
WRITE	Write Memory Code	0000 0010 _B
RDID	Read Device ID	1001 1111 _B

■ COMMAND

• WREN

The WREN command sets WEL (Write Enable Latch) . WEL has to be set with the WREN command before writing operation (WRSR command and WRITE command) .

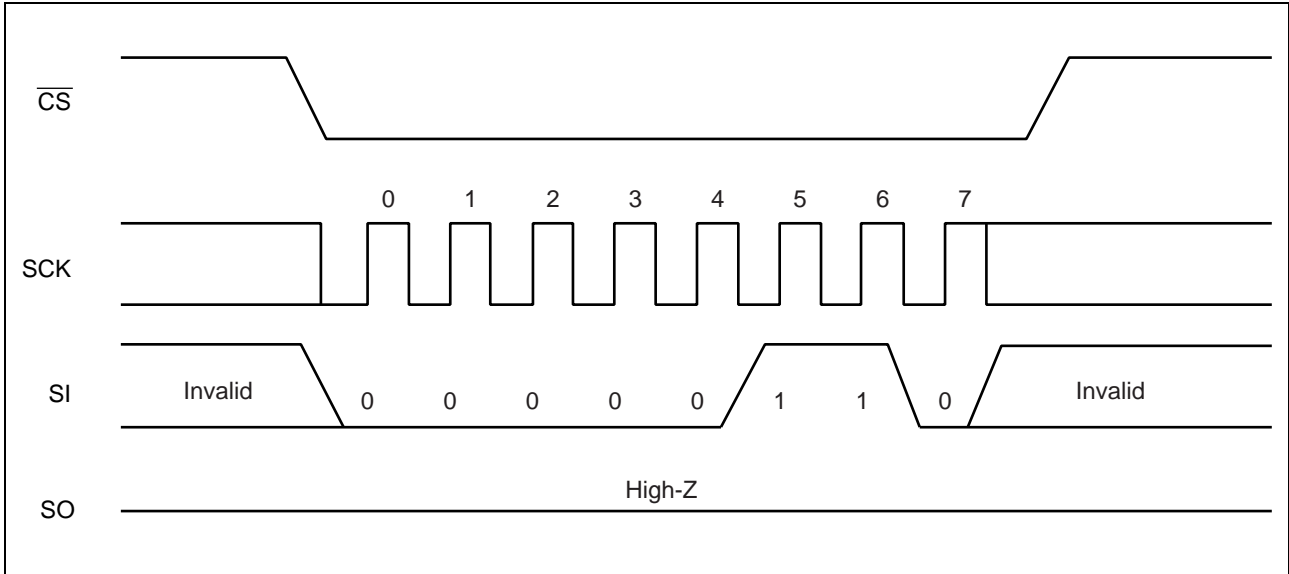

• WRDI

The WRDI command resets WEL (Write Enable Latch) . Writing operation (WRITE command and WRSR command) are not performed when WEL is reset.

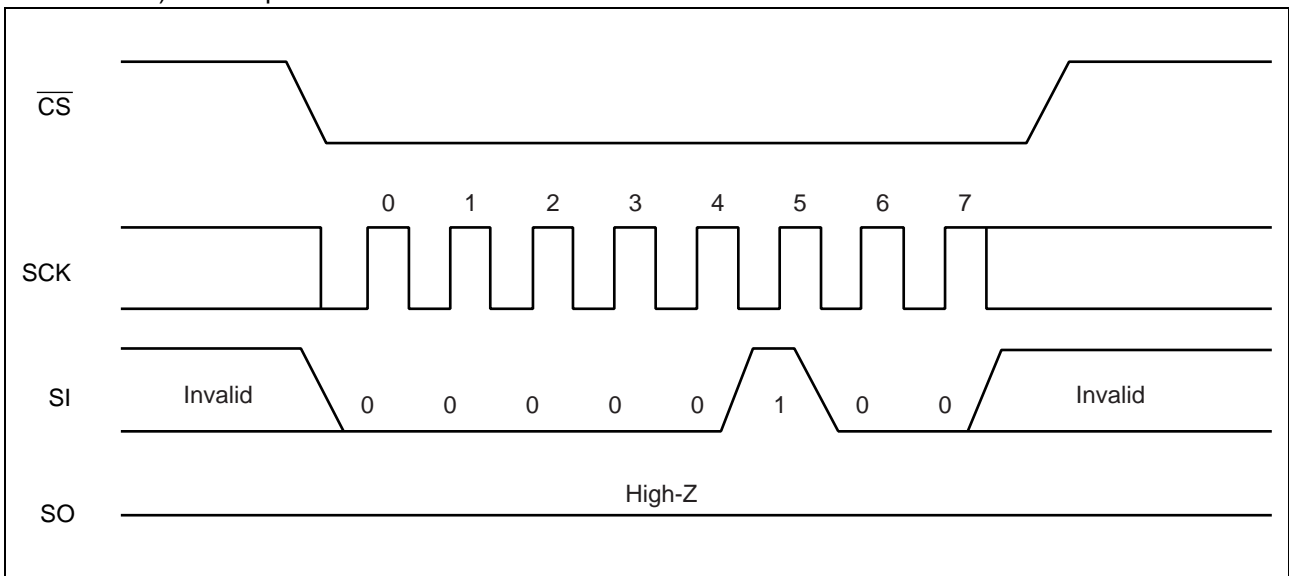

MB85RS64V

• RDSR

The RDSR command reads status register data. After op-code of RDSR is input to SI, 8-cycle clock is input to SCK. The SI value is invalid for this time. SO is output synchronously to a falling edge of SCK. In the RDSR command, repeated reading of status register is enabled by sending SCK continuously before rising of \overline{CS} .

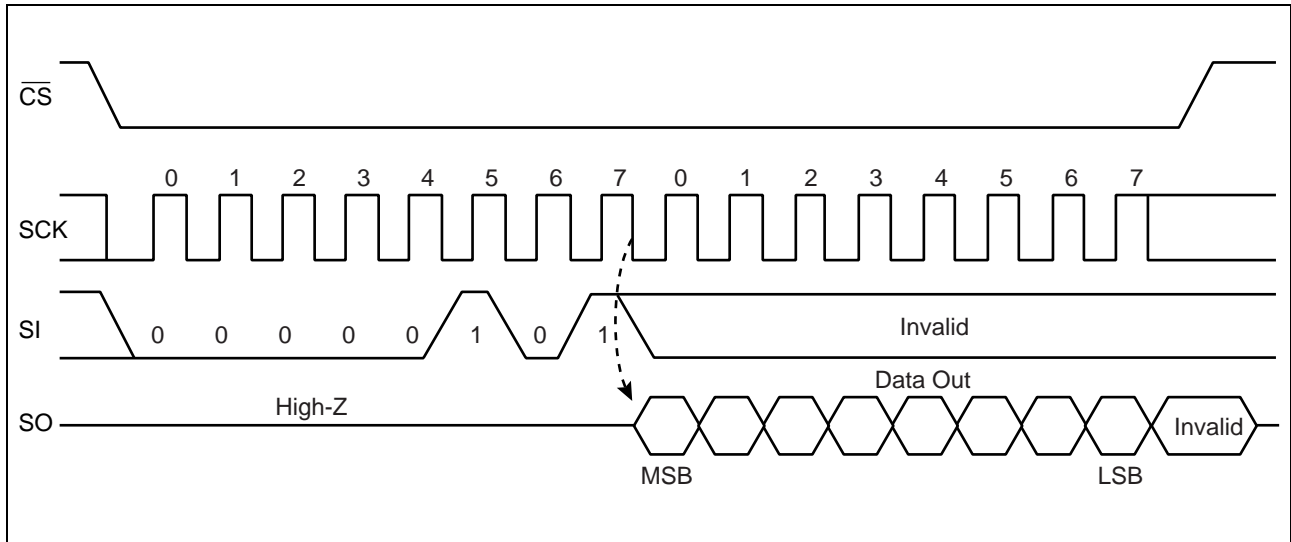

• WRSR

The WRSR command writes data to the nonvolatile memory bit of status register. After performing WRSR op-code to a SI pin, 8 bits writing data is input. WEL (Write Enable Latch) is not able to be written with WRSR command. A SI value correspondent to bit 1 is ignored. Bit 0 of the status register is fixed to "0" and cannot be written. The SI value corresponding to bit 0 is ignored. the \overline{WP} signal level shall be fixed before performing the WRSR command, and do not change the \overline{WP} signal level until the end of command sequence.

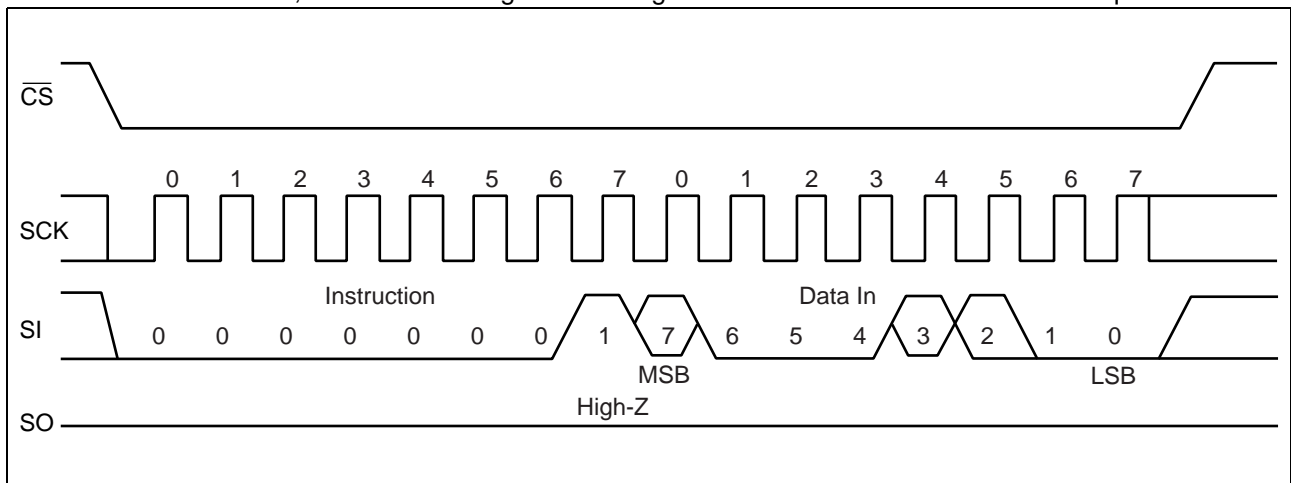

• READ

The READ command reads FRAM memory cell array data. Arbitrary 16 bits address and op-code of READ are input to SI. The 3-bit upper address bit is invalid. Then, 8-cycle clock is input to SCK. SO is output synchronously to the falling edge of SCK. While reading, the SI value is invalid. When \overline{CS} is risen, the READ command is completed, but keeps on reading with automatic address increment which is enabled by continuously sending clocks to SCK in unit of 8 cycles before \overline{CS} rising. When it reaches the most significant address, it rolls over to the starting address, and reading cycle keeps on infinitely.

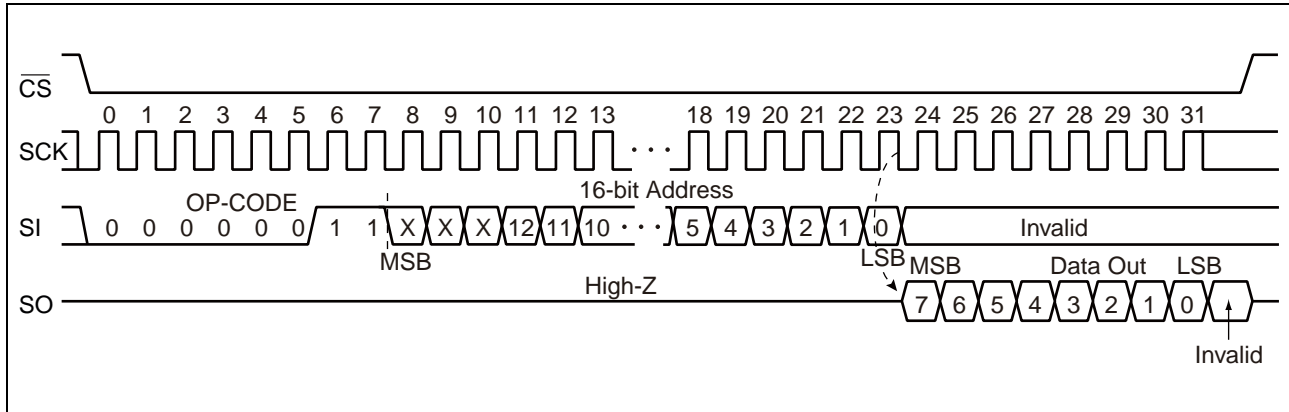

• WRITE

The WRITE command writes data to FRAM memory cell array. WRITE op-code, arbitrary 16 bits of address and 8 bits of writing data are input to SI. The 3-bit upper address bit is invalid. When 8 bits of writing data is input, data is written to FRAM memory cell array. Risen \overline{CS} will terminate the WRITE command, but if you continue sending the writing data for 8 bits each before \overline{CS} rising, it is possible to continue writing with automatic address increment. When it reaches the most significant address, it rolls over to the starting address, and writing cycle can be continued infinitely.

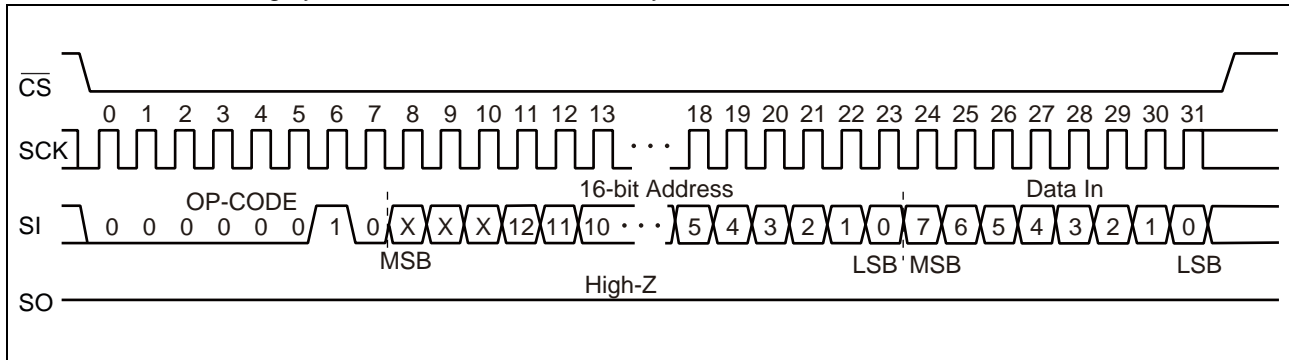

MB85RS64V

• RDID

The RDID command reads fixed Device ID. After performing RDID op-code to SI, 32-cycle clock is input to SCK. The SI value is invalid for this time. SO is output synchronously to a falling edge of SCK. The output is in order of Manufacturer ID (8bit)/Continuation code (8bit)/Product ID (1st Byte)/ Product ID (2nd Byte). In the RDID command, SO holds the output state of the last bit after 32-bit Device ID output by continuously sending SCK clock before CS is risen.

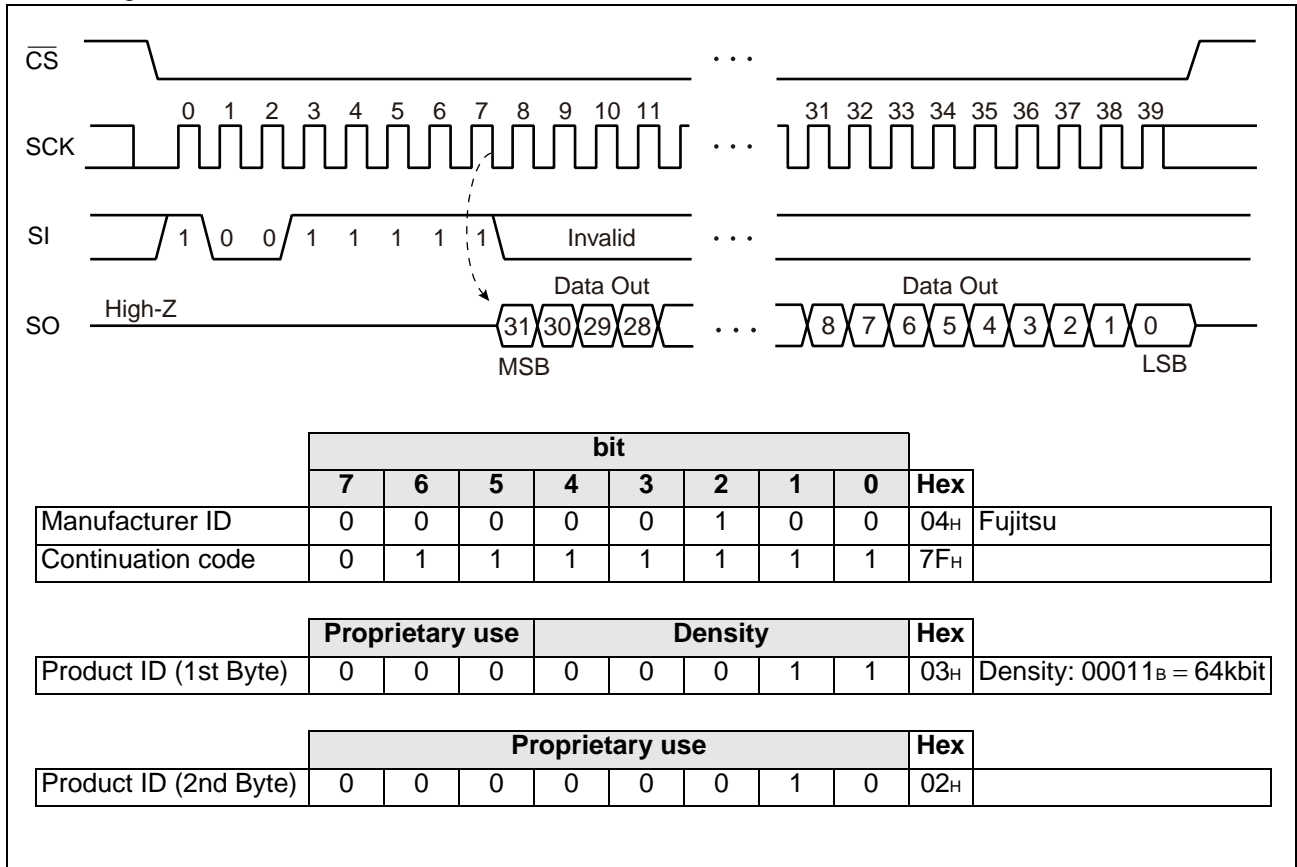

■ BLOCK PROTECT

Writing protect block for WRITE command is configured by the value of BP0 and BP1 in the status register.

BP1	BP0	Protected Block
0	0	None
0	1	1800 _H to 1FFF _H (upper 1/4)
1	0	1000 _H to 1FFF _H (upper 1/2)
1	1	0000 _H to 1FFF _H (all)

■ WRITING PROTECT

Writing operation of the WRITE command and the WRSR command are protected with the value of WEL, WPEN, WP as shown in the table.

WEL	WPEN	WP	Protected Blocks	Unprotected Blocks	Status Register
0	X	X	Protected	Protected	Protected
1	0	X	Protected	Unprotected	Unprotected
1	1	0	Protected	Unprotected	Protected
1	1	1	Protected	Unprotected	Unprotected

■ HOLD OPERATION

Hold status is retained without aborting a command if $\overline{\text{HOLD}}$ is the "L" level while $\overline{\text{CS}}$ is the "L" level. The timing for starting and ending hold status depends on the SCK to be the "H" level or the "L" level when a $\overline{\text{HOLD}}$ pin input is transitioned to the hold condition as shown in the diagram below. In case the $\overline{\text{HOLD}}$ pin transitioned to "L" level when SCK is "L" level, return the $\overline{\text{HOLD}}$ pin to "H" level at SCK being "L" level. In the same manner, in case the $\overline{\text{HOLD}}$ pin transitioned to "L" level when SCK is "H" level, return the $\overline{\text{HOLD}}$ pin to "H" level at SCK being "H" level. Arbitrary command operation is interrupted in hold status, SCK and SI inputs become don't care. And, SO becomes High-Z while reading command (RDSR, READ). If $\overline{\text{CS}}$ is rising during hold status, a command is aborted. In case the command is aborted before its recognition, WEL holds the value before transition to HOLD status.

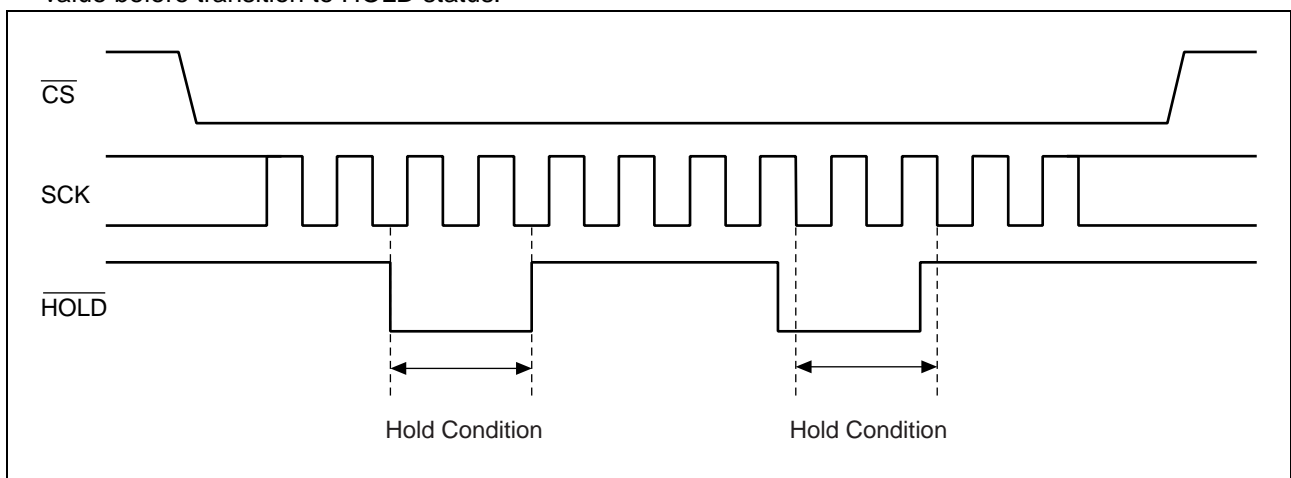

MB85RS64V

■ ABSOLUTE MAXIMUM RATINGS

Parameter	Symbol	Rating		Unit
		Min	Max	
Power supply voltage*	V_{DD}	- 0.5	+ 6.0	V
Input voltage*	V_{IN}	- 0.5	$V_{DD} + 0.5 (\leq 6.0)$	V
Output voltage*	V_{OUT}	- 0.5	$V_{DD} + 0.5 (\leq 6.0)$	V
Operation ambient temperature	T_A	- 40	+ 85	°C
Storage temperature	T_{stg}	- 55	+ 125	°C

*:These parameters are based on the condition that V_{SS} is 0 V.

WARNING: Semiconductor devices can be permanently damaged by application of stress (voltage, current, temperature, etc.) in excess of absolute maximum ratings. Do not exceed these ratings.

■ RECOMMENDED OPERATING CONDITIONS

Parameter	Symbol	Value			Unit
		Min	Typ	Max	
Power supply voltage*	V_{DD}	3.0	—	5.5	V
Input high voltage*	V_{IH}	$V_{DD} \times 0.8$	—	$V_{DD} + 0.3$	V
Input low voltage*	V_{IL}	- 0.3	—	$V_{DD} \times 0.2$	V
Operation ambient temperature	T_A	- 40	—	+ 85	°C

*:These parameters are based on the condition that V_{SS} is 0 V.

WARNING: The recommended operating conditions are required in order to ensure the normal operation of the semiconductor device. All of the device's electrical characteristics are warranted when the device is operated within these ranges.

Always use semiconductor devices within their recommended operating condition ranges. Operation outside these ranges may adversely affect reliability and could result in device failure.

No warranty is made with respect to uses, operating conditions, or combinations not represented on the data sheet. Users considering application outside the listed conditions are advised to contact their representatives beforehand.

■ ELECTRICAL CHARACTERISTICS

1. DC Characteristics

(within recommended operating conditions)

Parameter	Symbol	Condition	Value			Unit
			Min	Typ	Max	
Input leakage current	I _{LI}	$0 \leq \overline{CS} < V_{DD}$	—	—	200	μA
		$\overline{CS} = V_{DD}$	—	—	10	
		$\overline{WP}, \overline{HOLD}, SCK,$ $SI = 0 \text{ V to } V_{DD}$	—	—	10	
Output leakage current	I _{LO}	$SO = 0 \text{ V to } V_{DD}$	—	—	10	μA
Operating power supply current	I _{DD}	SCK = 20 MHz	—	1.5	2.5	mA
Standby current	I _{SB}	SCK = SI = $\overline{CS} = V_{DD}$	—	10	20	μA
Output high voltage	V _{OH}	I _{OH} = -2 mA	V _{DD} - 0.5	—	V _{DD}	V
Output low voltage	V _{OL}	I _{OL} = 2 mA	V _{SS}	—	0.4	V
Pull up resistance for \overline{CS}	R _P	—	28	50	180	kΩ

2. AC Characteristics

Parameter	Symbol	Value		Unit
		Min	Max	
SCK clock frequency	f _{CK}	0	20	MHz
Clock high time	t _{CH}	25	—	ns
Clock low time	t _{CL}	25	—	ns
Chip select set up time	t _{CSU}	10	—	ns
Chip select hold time	t _{CSH}	10	—	ns
Output disable time	t _{OD}	—	20	ns
Output data valid time	t _{ODV}	—	20	ns
Output hold time	t _{OH}	0	—	ns
Deselect time	t _D	60	—	ns
Data in rising time	t _R	—	50	ns
Data falling time	t _F	—	50	ns
Data set up time	t _{SU}	5	—	ns
Data hold time	t _H	5	—	ns
$\overline{\text{HOLD}}$ set up time	t _{HS}	10	—	ns
$\overline{\text{HOLD}}$ hold time	t _{HH}	10	—	ns
$\overline{\text{HOLD}}$ output floating time	t _{HZ}	—	20	ns
$\overline{\text{HOLD}}$ output active time	t _{LZ}	—	20	ns

AC Test Condition

Power supply voltage : 3.0 V to 5.5 V
 Operation ambient temperature : - 40 °C to + 85 °C
 Input voltage magnitude : $V_{DD} \times 0.1$ to $V_{DD} \times 0.9$
 Input rising time : 5 ns
 Input falling time : 5 ns
 Input judge level : $V_{DD}/2$
 Output judge level : $V_{DD}/2$

AC Load Equivalent Circuit

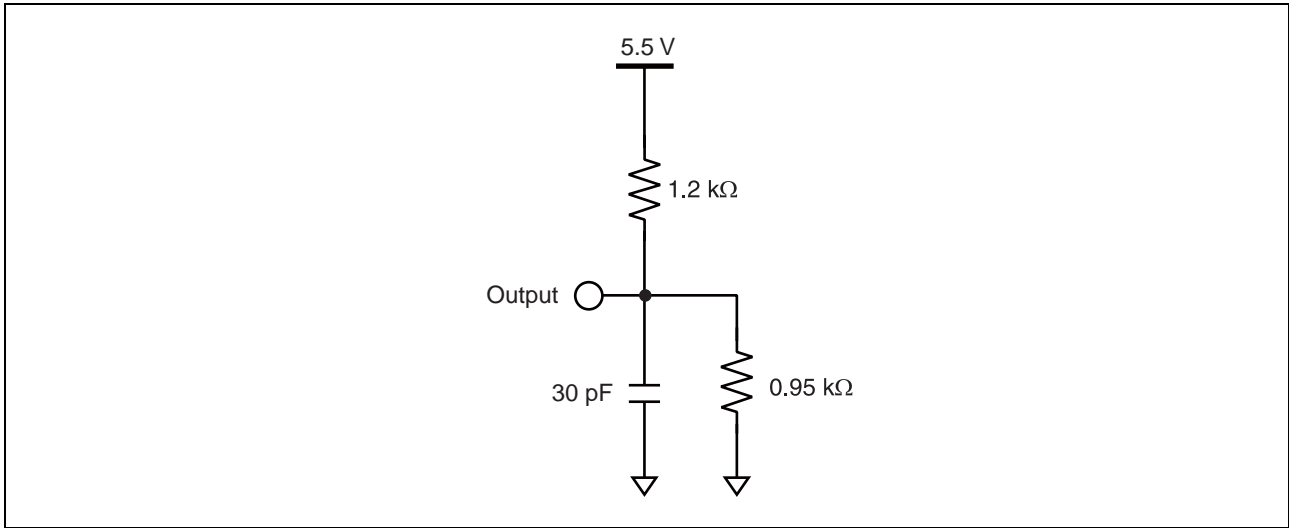

3. Pin Capacitance

Parameter	Symbol	Conditions	Value		Unit
			Min	Max	
Output capacitance	C_o	$V_{DD} = V_{IN} = V_{OUT} = 0\text{ V}$ $f = 1\text{ MHz}, T_A = +25\text{ °C}$	—	10	pF
Input capacitance	C_i		—	10	pF

■ TIMING DIAGRAM

• Serial Data Timing

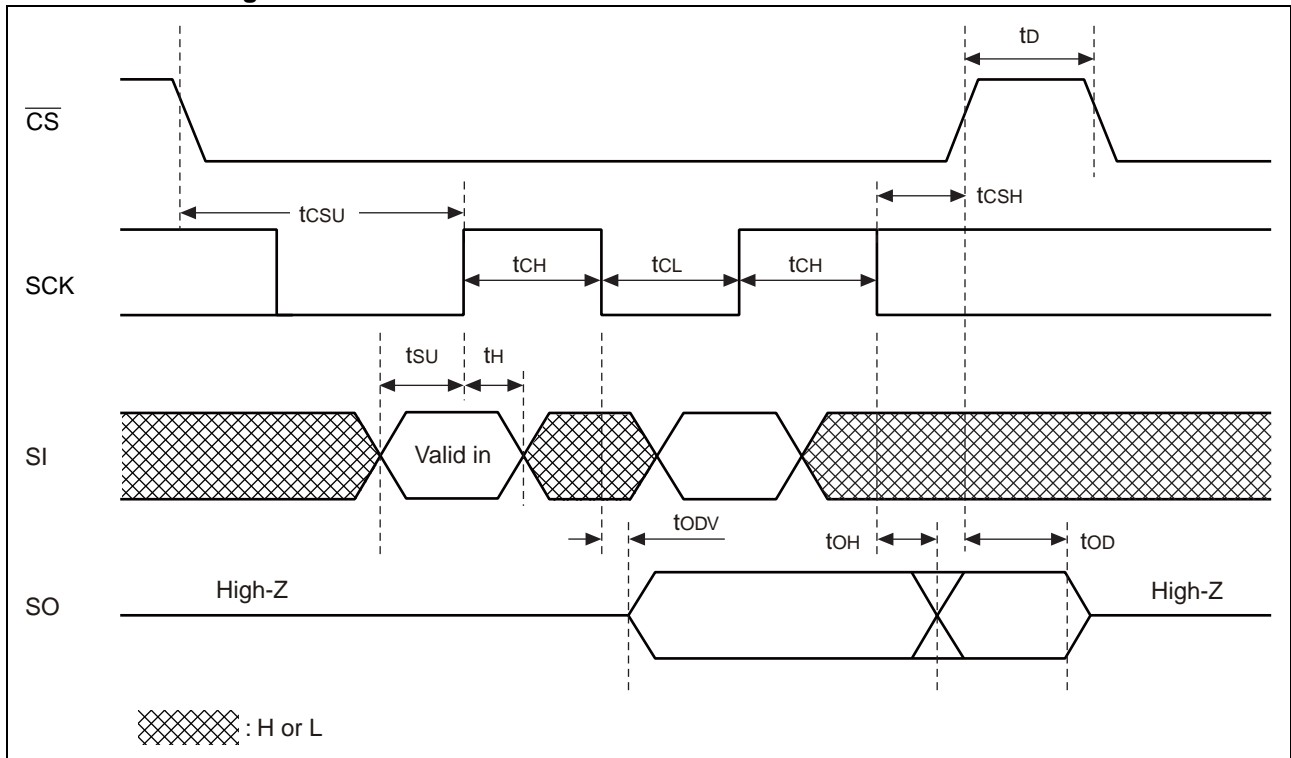

• Hold Timing

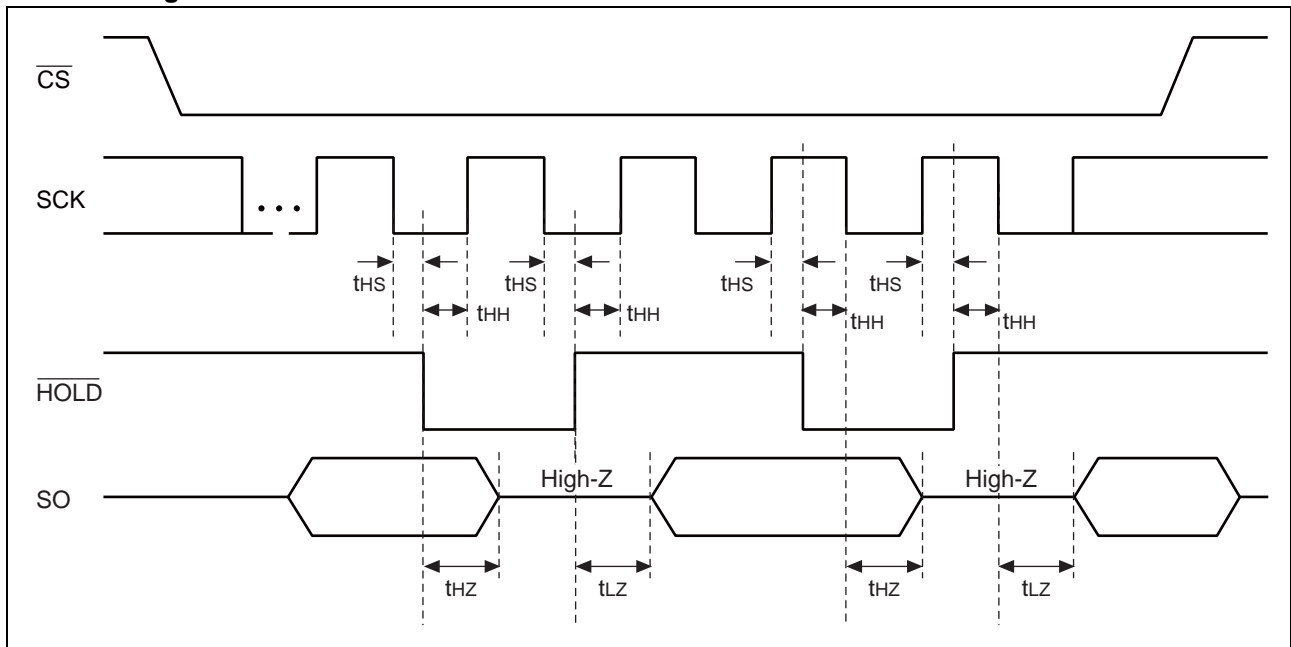

POWER ON/OFF SEQUENCE

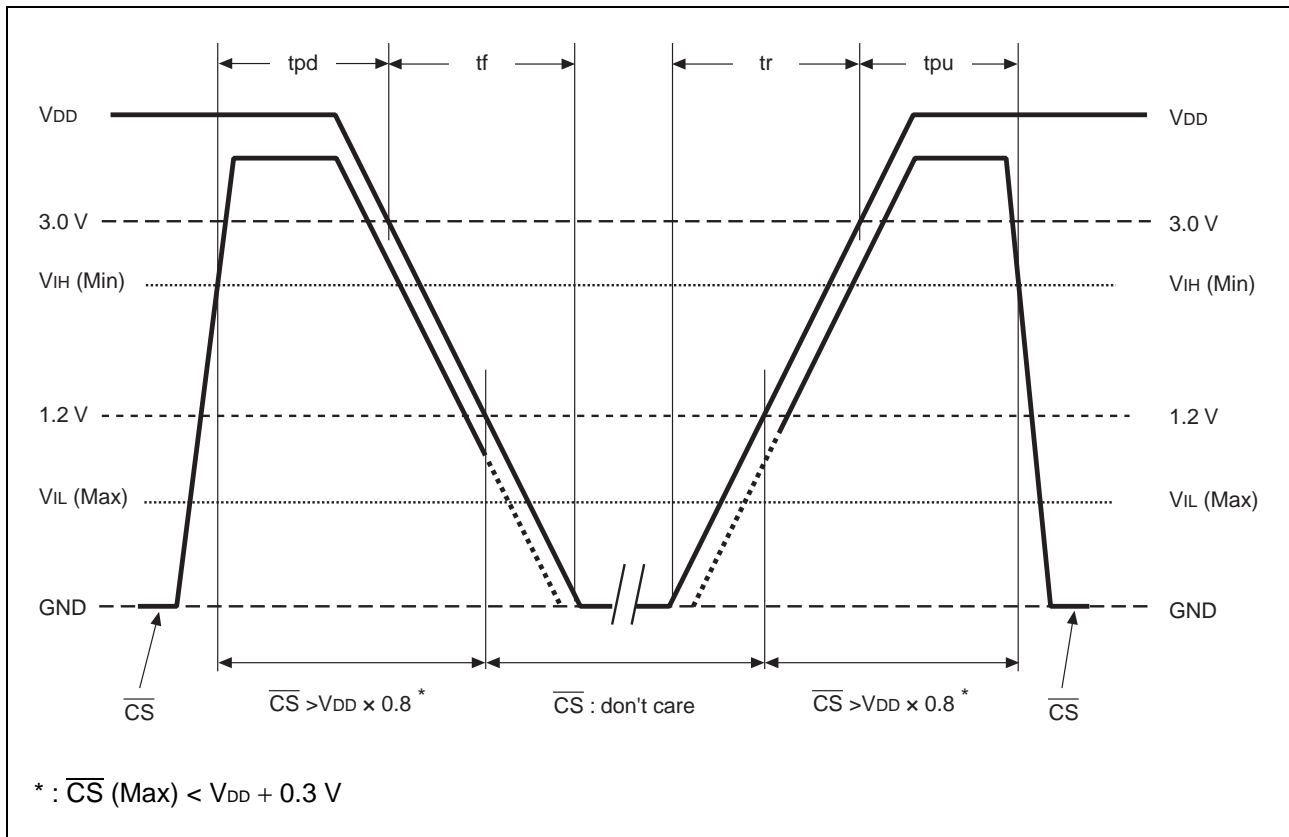

Parameter	Symbol	Value		Unit
		Min	Max	
\overline{CS} level hold time at power OFF	tpd	400	—	ns
\overline{CS} level hold time at power ON	tpu	0.1	—	ms
Power supply falling time	tf	200	—	$\mu\text{s/V}$
Power supply rising time	tr	100	—	$\mu\text{s/V}$

If the device does not operate within the specified conditions of read cycle, write cycle or power on/off sequence, memory data can not be guaranteed.

FRAM CHARACTERISTICS

Item	Min	Max	Unit	Parameter
Read/Write Endurance*1	10^{12}	—	Times/byte	Operation Ambient Temperature $T_A = +85 \text{ }^\circ\text{C}$
Data Retention*2	10	—	Years	Operation Ambient Temperature $T_A = +85 \text{ }^\circ\text{C}$
	95	—		Operation Ambient Temperature $T_A = +55 \text{ }^\circ\text{C}$
	≥ 200	—		Operation Ambient Temperature $T_A = +35 \text{ }^\circ\text{C}$

*1 : Total number of reading and writing defines the minimum value of endurance, as an FRAM memory operates with destructive readout mechanism.

*2 : Minimum values define retention time of the first reading/writing data right after shipment, and these values are calculated by qualification results.

NOTE ON USE

Data written before performing IR reflow is not guaranteed after IR reflow.

■ ESD AND LATCH-UP

Test	DUT	Value
ESD HBM (Human Body Model) JESD22-A114 compliant	MB85RS64VPNF-G-JNE1	$\geq 2000 \text{ V} $
ESD MM (Machine Model) JESD22-A115 compliant		$\geq 200 \text{ V} $
ESD CDM (Charged Device Model) JESD22-C101 compliant		$\geq 1000 \text{ V} $
Latch-Up (I-test) JESD78 compliant		—
Latch-Up (V_{supply} overvoltage test) JESD78 compliant		—
Latch-Up (Current Method) Proprietary method		—
Latch-Up (C-V Method) Proprietary method		$\geq 200 \text{ V} $

- Current method of Latch-Up Resistance Test

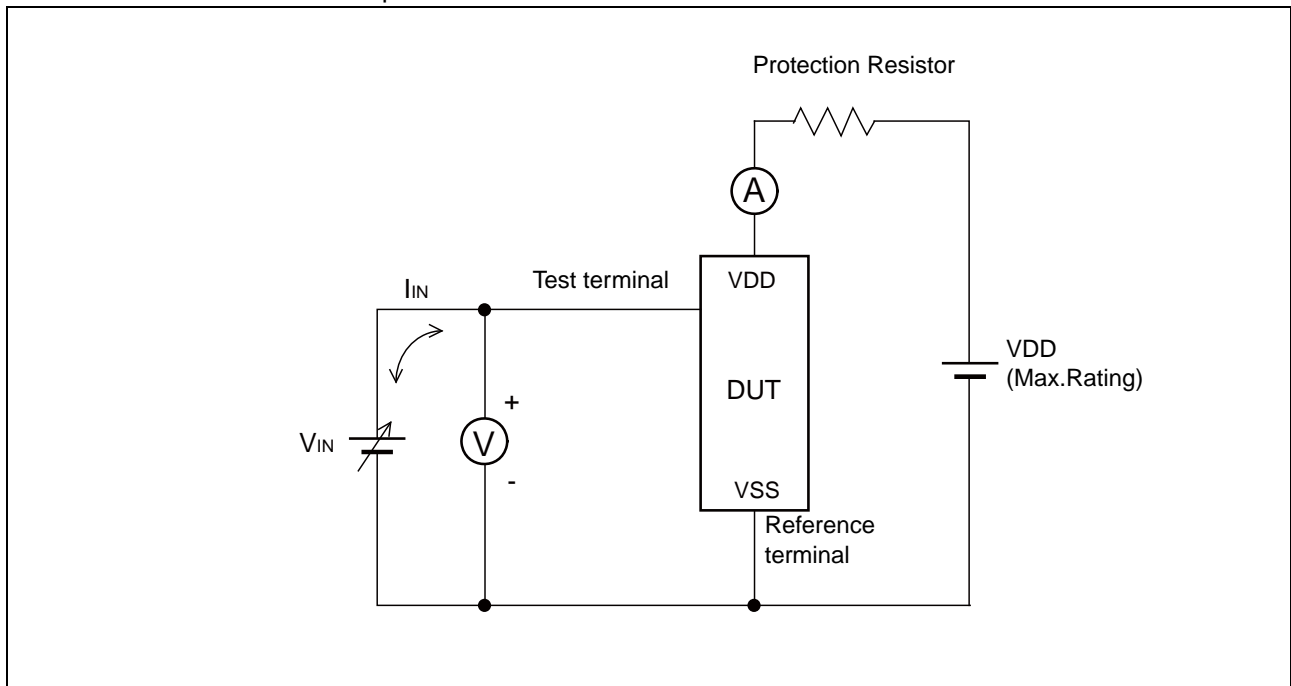

Note : The voltage V_{IN} is increased gradually and the current I_{IN} of 300 mA at maximum shall flow.
 Confirm the latch up does not occur under $I_{IN} = \pm 300 \text{ mA}$.
 In case the specific requirement is specified for I/O and I_{IN} cannot be 300 mA, the voltage shall be increased to the level that meets the specific requirement.

- C-V method of Latch-Up Resistance Test

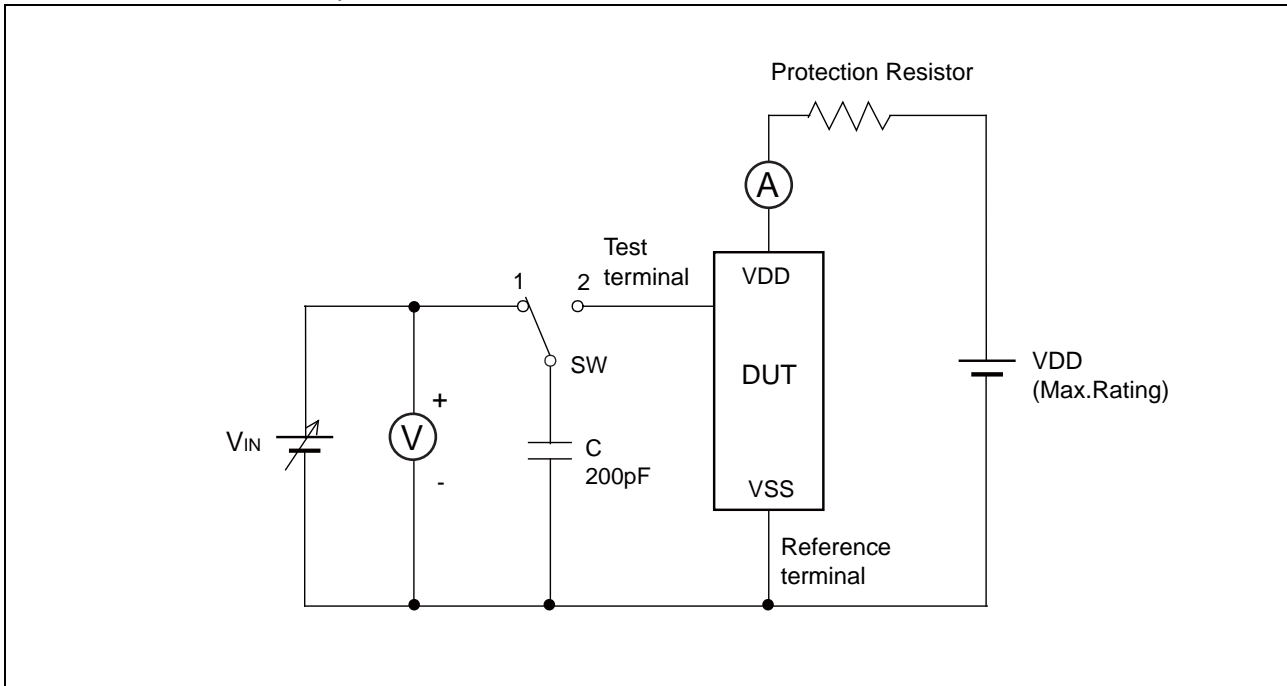

Note : Charge voltage alternately switching 1 and 2 approximately 2 sec interval. This switching process is considered as one cycle.
 Repeat this process 5 times. However, if the latch-up condition occurs before completing 5 times, this test must be stopped immediately.

REFLOW CONDITIONS AND FLOOR LIFE

Item	Condition	
Method	IR (infrared reflow) , Convection	
Times	2	
Floor life	Before unpacking	Please use within 2 years after production.
	From unpacking to 2nd reflow	Within 8 days
	In case over period of floor life	Baking with 125 °C+/-3 °C for 24hrs+2hrs-0hrs is required. Then please use within 8 days. (Please remember baking is up to 2 times)
Floor life condition	Between 5 °C and 30 °C and also below 70%RH required. (It is preferred lower humidity in the required temp range.)	

Reflow Profile

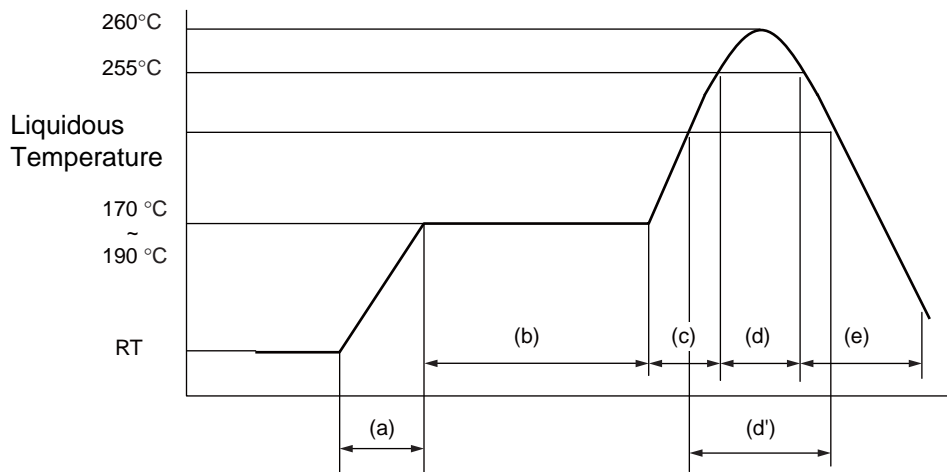

- (a) Average ramp-up rate : 1 °C/s to 4 °C/s
- (b) Preheat & Soak : 170 °C to 190 °C, 60 s to 180 s
- (c) Average ramp-up rate : 1 °C/s to 4 °C/s
- (d) Peak temperature : Temperature 260 °C Max; 255 °C within 10 s
- (d') Liquidous temperature : Up to 230 °C within 40 s or
Up to 225 °C within 60 s or
Up to 220 °C within 80 s
- (e) Cooling : Natural cooling or forced cooling

Note : Temperature on the top of the package body is measured.

■ RESTRICTED SUBSTANCES

This product complies with the regulations below (Based on current knowledge as of November 2011).

- EU RoHS Directive (2002/95/EC)
- China RoHS (Administration on the Control of Pollution Caused by Electronic Information Products
(电子信息产品污染控制管理办法))
- Vietnam RoHS (30/2011/TT-BCT)

Restricted substances in each regulation are as follows.

Substances	Threshold	Contain status*
Lead and its compounds	1,000 ppm	○
Mercury and its compounds	1,000 ppm	○
Cadmium and its compounds	100 ppm	○
Hexavalent chromium compound	1,000 ppm	○
Polybrominated biphenyls (PBB)	1,000 ppm	○
Polybrominated diphenyl ethers (PBDE)	1,000 ppm	○

* : The mark of "○" shows below a threshold value.

MB85RS64V

■ ORDERING INFORMATION

Part number	Package	Shipping form	Minimum shipping quantity
MB85RS64VPNF-G-JNE1	8-pin plastic SOP (FPT-8P-M02)	Tube	1
MB85RS64VPNF-G-JNERE1	8-pin plastic SOP (FPT-8P-M02)	Embossed Carrier tape	1500

PACKAGE DIMENSION

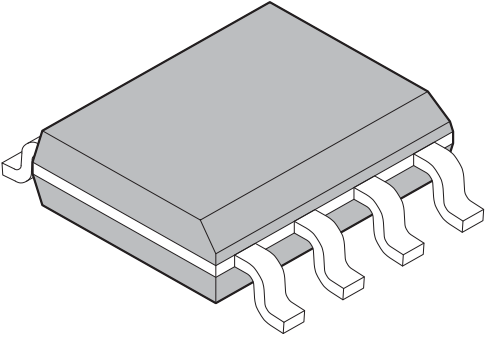
<p>8-pin plastic SOP</p>  <p>(FPT-8P-M02)</p>	Lead pitch	1.27 mm
	Package width × package length	3.9 mm × 5.05 mm
	Lead shape	Gullwing
	Sealing method	Plastic mold
	Mounting height	1.75 mm MAX
	Weight	0.06 g

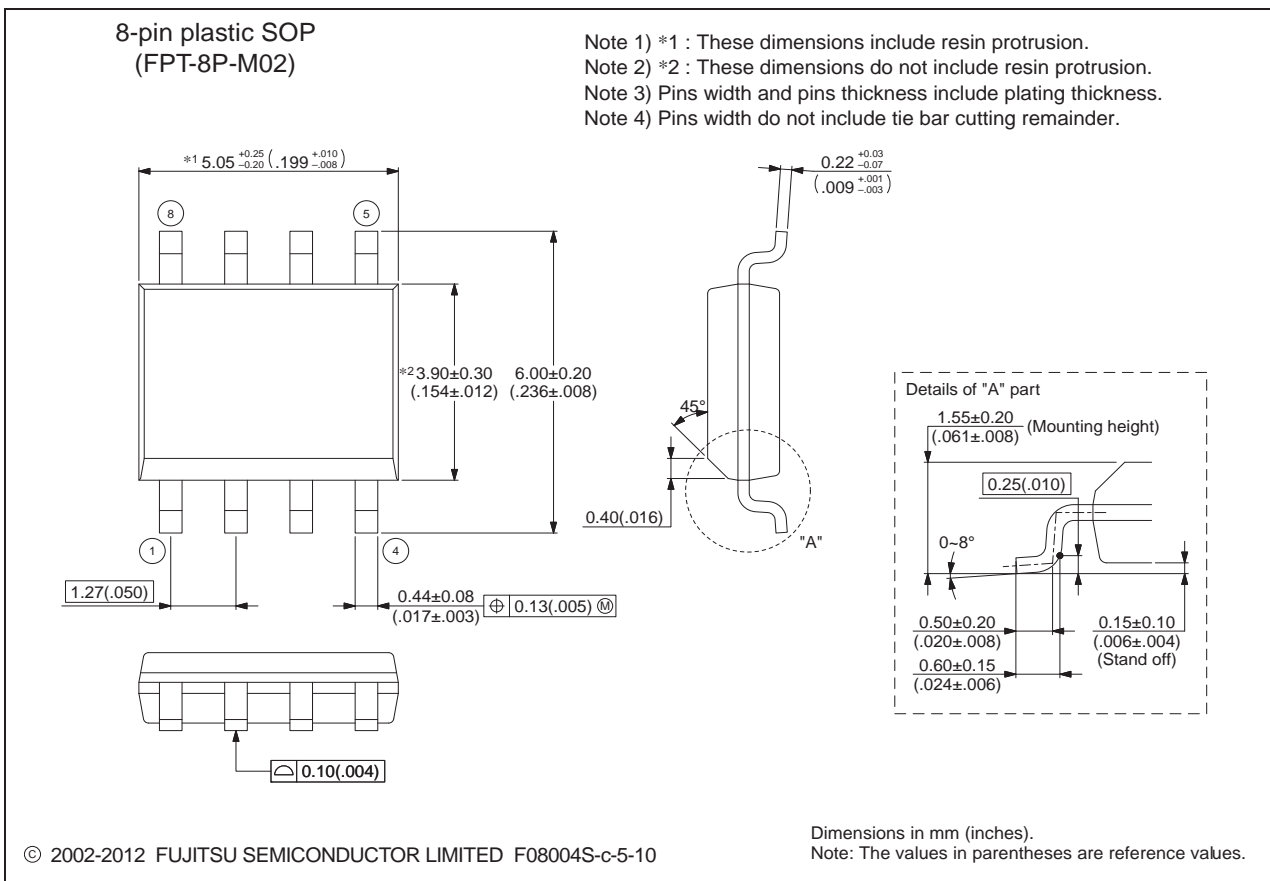

Please check the latest package dimension at the following URL.
<http://edevice.fujitsu.com/package/en-search/>

■ MARKING

[MB85RS64VPNF-G-JNE1]
[MB85RS64VPNF-G-JNERE1]



[FPT-8P-M02]

■ PACKING INFORMATION

1. Tube

1.1 Tube Dimensions

- Tube/stopper shape

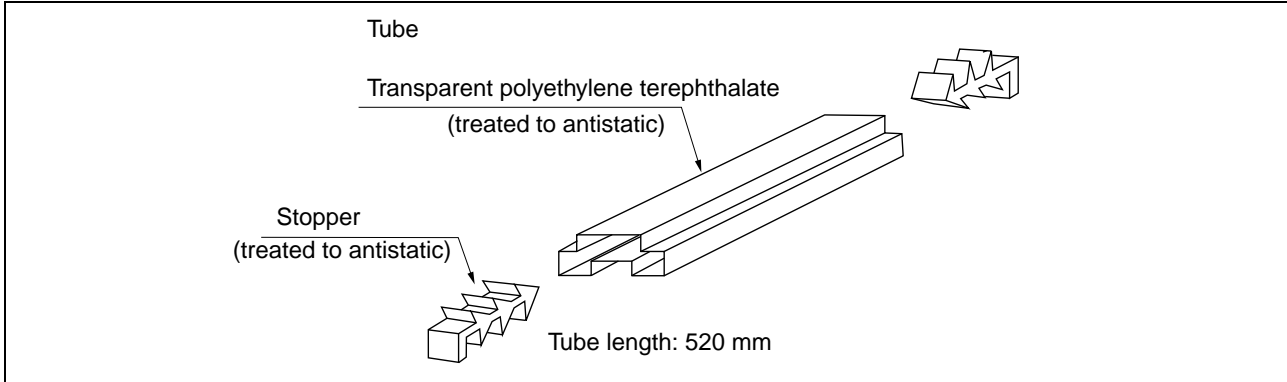

Tube cross-sections and Maximum quantity

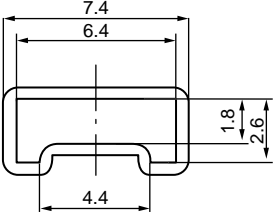
Package form	Package code	Maximum quantity		
		pcs/ tube	pcs/inner box	pcs/outer box
SOP, 8, plastic (2)  ©2006-2010 FUJITSU SEMICONDUCTOR LIMITED F08008-SET1-PET:FJ99L-0022-E0008-1-K-3 $t = 0.5$ Transparent polyethylene terephthalate	FPT-8P-M02	95	7600	30400

(Dimensions in mm)

MB85RS64V

1.2 Tube Dry pack packing specifications

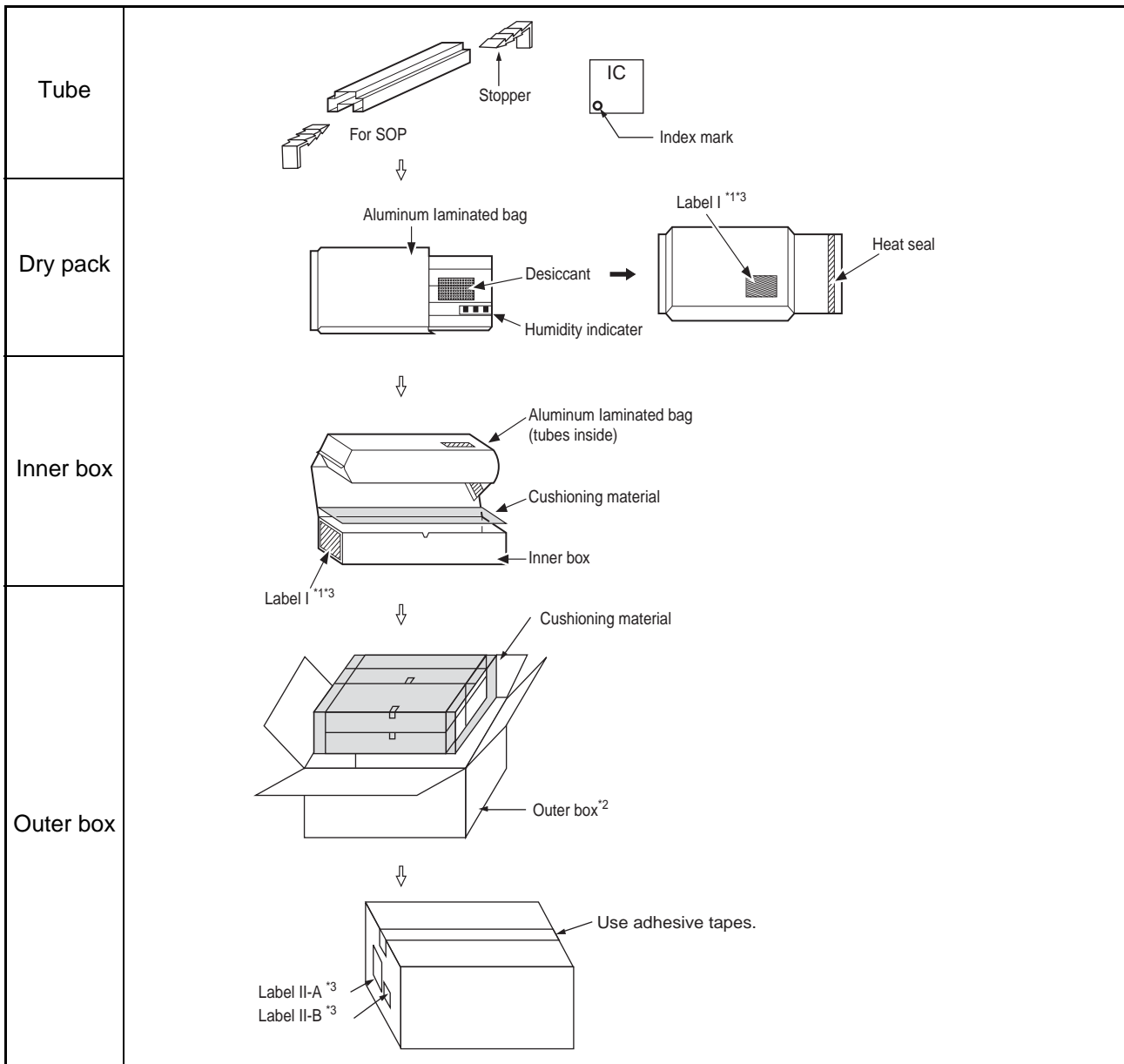

*1: For a product of which part number is suffixed with "E1", a "G" (Pb) mark is displayed to the moisture barrier bag and the inner boxes.

*2: The space in the outer box will be filled with empty inner boxes, or cushions, etc.

*3: Please refer to an attached sheet about the indication label.

Note: The packing specifications may not be applied when the product is delivered via a distributor.

1.3 Product label indicators

Label I: Label on Inner box/Moisture Barrier Bag/ (It sticks it on the reel for the emboss taping)
 [C-3 Label (50mm × 100mm) Supplemental Label (20mm × 100mm)]

XXXXXXXXXXXXXXXX (Customer part number or FJ part number)	← C-3 Label
(3N)1 XXXXXXXXXXXXXXXX XXX (LEAD FREE mark) (Part number and quantity)	
XXXXXXXXXXXXXXXXXXXX (FJ control number)	
XXXXXXXXXXXXXXXXXXXX (Customer part number or FJ part number)	
XXXXXXXXXXXXXXXXXXXX (Customer part number or FJ part number bar code)	
XXXX/XX/XX (Packed years/month/day) ASSEMBLED IN xxxx	← Perforated line
XXXXXXXXXXXXXXXXXXXX (Customer part number or FJ part number)	← Supplemental Label
XXXXXXXXXXXXXXXXXXXX (FJ control number bar code)	
XXXXXXXXXXXX (Package count) XXXX-XXX XXX	
XXXXXXXXXXXX (FJ control number) (Lot Number and quantity)	
XXXXXXXXXXXXXXXXXXXX (Comment)	

Label II-A: Label on Outer box [D Label] (100mm × 100mm)

<table border="1"> <tr> <td>発注者 XXXXXXXXXXXXXXXX (Customer Name) (CUST.)</td> <td>受注者 (VENDOR) 富士通</td> </tr> <tr> <td>受渡場所名 XXXXXXXXXXXX (Delivery Address) (DELIVERY POINT)</td> <td>セミコンダクター株式会社</td> </tr> <tr> <td>納品キー番号 XXXXXXXXXXXXXXXX (TRANS.NO.) (FJ control number)</td> <td>XXX (FJ control number)</td> </tr> <tr> <td>品名コード XXXXXXXXXXXXXXXX (PART NO.) (Customer part number or FJ part number)</td> <td>XXX (FJ control number)</td> </tr> <tr> <td></td> <td>XXXXXXXXXXXXXXXXXXXX (Part number)</td> </tr> <tr> <td colspan="2">品名 (PART NAME) XXXXXXXXXXXXXXXX (Part number)</td> </tr> <tr> <td>入数/納入数量 XXX/XXX (Q'TY/TOTAL Q'TY)</td> <td>単位 XX (UNIT)</td> </tr> <tr> <td>発注者用備考 (CUSTOMER'S REMARKS) XXXXXXXXXXXXXXXXXXXX</td> <td>梱包個数 (PACKAGE COUNT) XXX/XXX</td> </tr> </table>	発注者 XXXXXXXXXXXXXXXX (Customer Name) (CUST.)	受注者 (VENDOR) 富士通	受渡場所名 XXXXXXXXXXXX (Delivery Address) (DELIVERY POINT)	セミコンダクター株式会社	納品キー番号 XXXXXXXXXXXXXXXX (TRANS.NO.) (FJ control number)	XXX (FJ control number)	品名コード XXXXXXXXXXXXXXXX (PART NO.) (Customer part number or FJ part number)	XXX (FJ control number)		XXXXXXXXXXXXXXXXXXXX (Part number)	品名 (PART NAME) XXXXXXXXXXXXXXXX (Part number)		入数/納入数量 XXX/XXX (Q'TY/TOTAL Q'TY)	単位 XX (UNIT)	発注者用備考 (CUSTOMER'S REMARKS) XXXXXXXXXXXXXXXXXXXX	梱包個数 (PACKAGE COUNT) XXX/XXX	← D Label
発注者 XXXXXXXXXXXXXXXX (Customer Name) (CUST.)	受注者 (VENDOR) 富士通																
受渡場所名 XXXXXXXXXXXX (Delivery Address) (DELIVERY POINT)	セミコンダクター株式会社																
納品キー番号 XXXXXXXXXXXXXXXX (TRANS.NO.) (FJ control number)	XXX (FJ control number)																
品名コード XXXXXXXXXXXXXXXX (PART NO.) (Customer part number or FJ part number)	XXX (FJ control number)																
	XXXXXXXXXXXXXXXXXXXX (Part number)																
品名 (PART NAME) XXXXXXXXXXXXXXXX (Part number)																	
入数/納入数量 XXX/XXX (Q'TY/TOTAL Q'TY)	単位 XX (UNIT)																
発注者用備考 (CUSTOMER'S REMARKS) XXXXXXXXXXXXXXXXXXXX	梱包個数 (PACKAGE COUNT) XXX/XXX																
(3N)3 XXXXXXXXXXXXXXXX XXX (FJ control number + Product quantity)																	
XXXXXXXXXXXXXXXXXXXX (FJ control number + Product quantity bar code)																	
(3N)4 XXXXXXXXXXXXXXXX XXX (Part number + Product quantity)																	
XXXXXXXXXXXXXXXXXXXX (Part number + Product quantity bar code)																	
(3N)5 XXXXXXXXXXXXXXXX (FJ control number)																	
XXXXXXXXXXXXXXXXXXXX (FJ control number bar code)																	

Label II-B: Outer boxes product indicate

XXXXXXXXXXXXXXXXXXXX (Part number)
(Lot Number) (Count) (Quantity)
XXXX-XXX X 箱 XXX 個
XXXX-XXX X 箱 XXX 個
計 XXX 個

Note: Depending on shipment state, "Label II-A" and "Label II-B" on the external boxes might not be printed.

MB85RS64V

1.4 Dimensions for Containers

(1) Dimensions for inner box

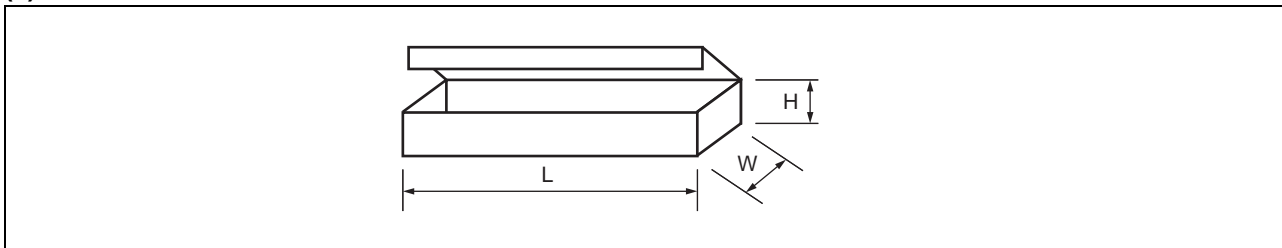

L	W	H
540	125	75

(Dimensions in mm)

(2) Dimensions for outer box

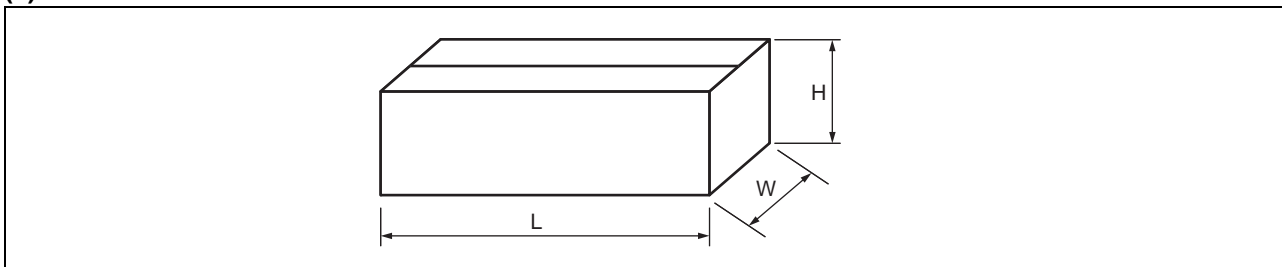

L	W	H
565	270	180

(Dimensions in mm)

2. Emboss Tape

2.1 Tape Dimensions

PKG code	Reel No	Maximum storage capacity		
		pcs/reel	pcs/inner box	pcs/outer box
FPT-8P-M02	3	1500	1500	10500

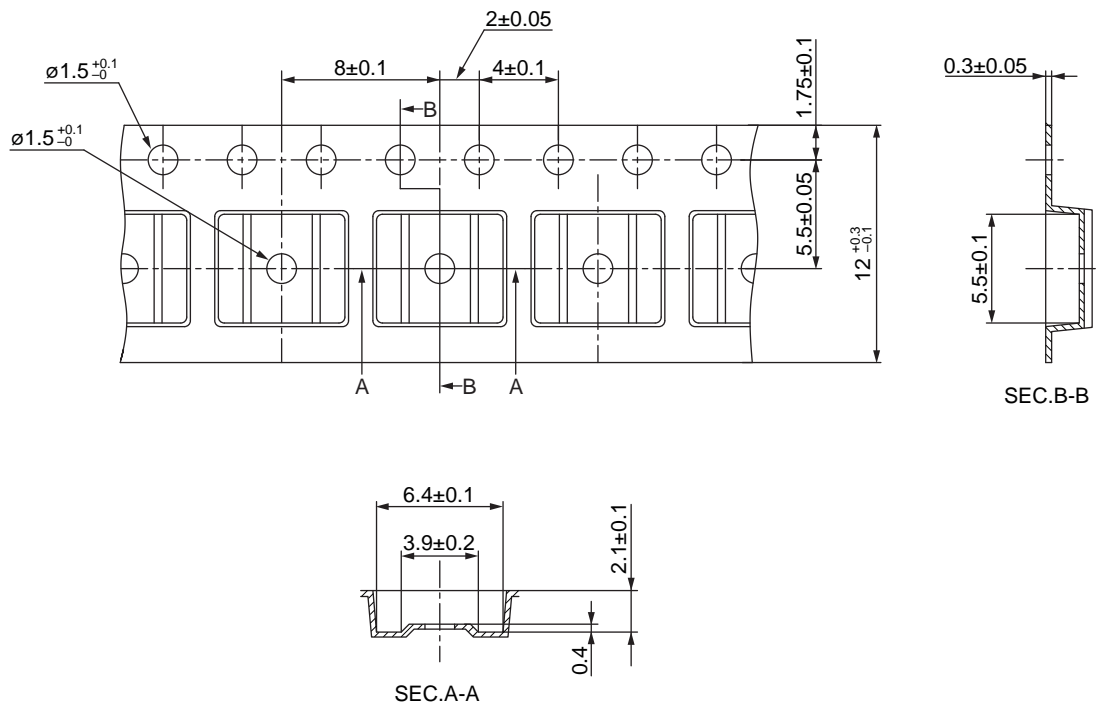

© 2012 FUJITSU SEMICONDUCTOR LIMITED SOL8-EMBOSSTAPE9 : NFME-EMB-X0084-1-P-1

(Dimensions in mm)

Material : Conductive polystyrene

Heat proof temperature : No heat resistance.

Package should not be baked
by using tape and reel.

MB85RS64V

2.2 IC orientation

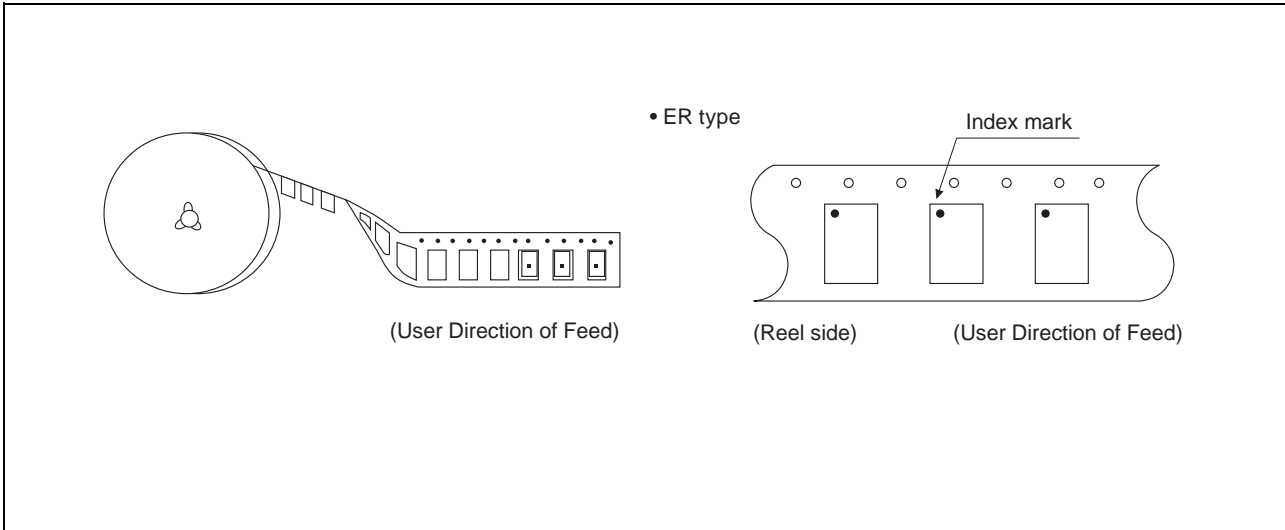

2.3 Reel dimensions

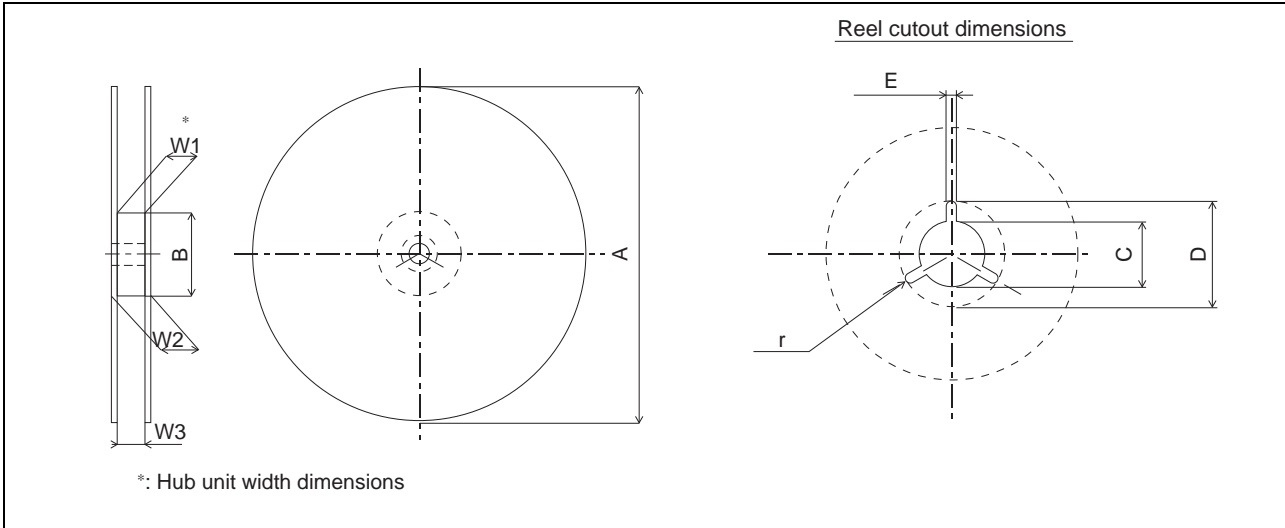

Dimensions in mm

Reel No	1	2	3	4	5	6	7	8	9	10	11	12	13	14	15
Tape width Symbol	8	12		16		24		32		44		56	12	16	24
A	254 ± 2	254 ± 2	330 ± 2	254 ± 2	330 ± 2	254 ± 2	330 ± 2	330 ± 2							
B	100 ⁺² ₋₀							100 ⁺² ₋₀	150 ⁺² ₋₀	100 ⁺² ₋₀	150 ⁺² ₋₀	100 ⁺² ₋₀	100 ± 2		
C	13 ± 0.2												13 ^{+0.5} _{-0.2}		
D	21 ± 0.8												20.5 ⁺¹ _{-0.2}		
E	2 ± 0.5														
W1	8.4 ⁺² ₋₀	12.4 ⁺² ₋₀		16.4 ⁺² ₋₀		24.4 ⁺² ₋₀		32.4 ⁺² ₋₀		44.4 ⁺² ₋₀		56.4 ⁺² ₋₀	12.4 ⁺¹ ₋₀	16.4 ⁺¹ ₋₀	24.4 ^{+0.1} ₋₀
W2	less than 14.4	less than 18.4		less than 22.4		less than 30.4		less than 38.4		less than 50.4		less than 62.4	less than 18.4	less than 22.4	less than 30.4
W3	7.9 ~ 10.9	11.9 ~ 15.4		15.9 ~ 19.4		23.9 ~ 27.4		31.9 ~ 35.4		43.9 ~ 47.4		55.9 ~ 59.4	12.4 ~ 14.4	16.4 ~ 18.4	24.4 ~ 26.4
r	1.0														

2.4 Taping (ϕ 330mm Reel) Dry Pack Packing Specifications

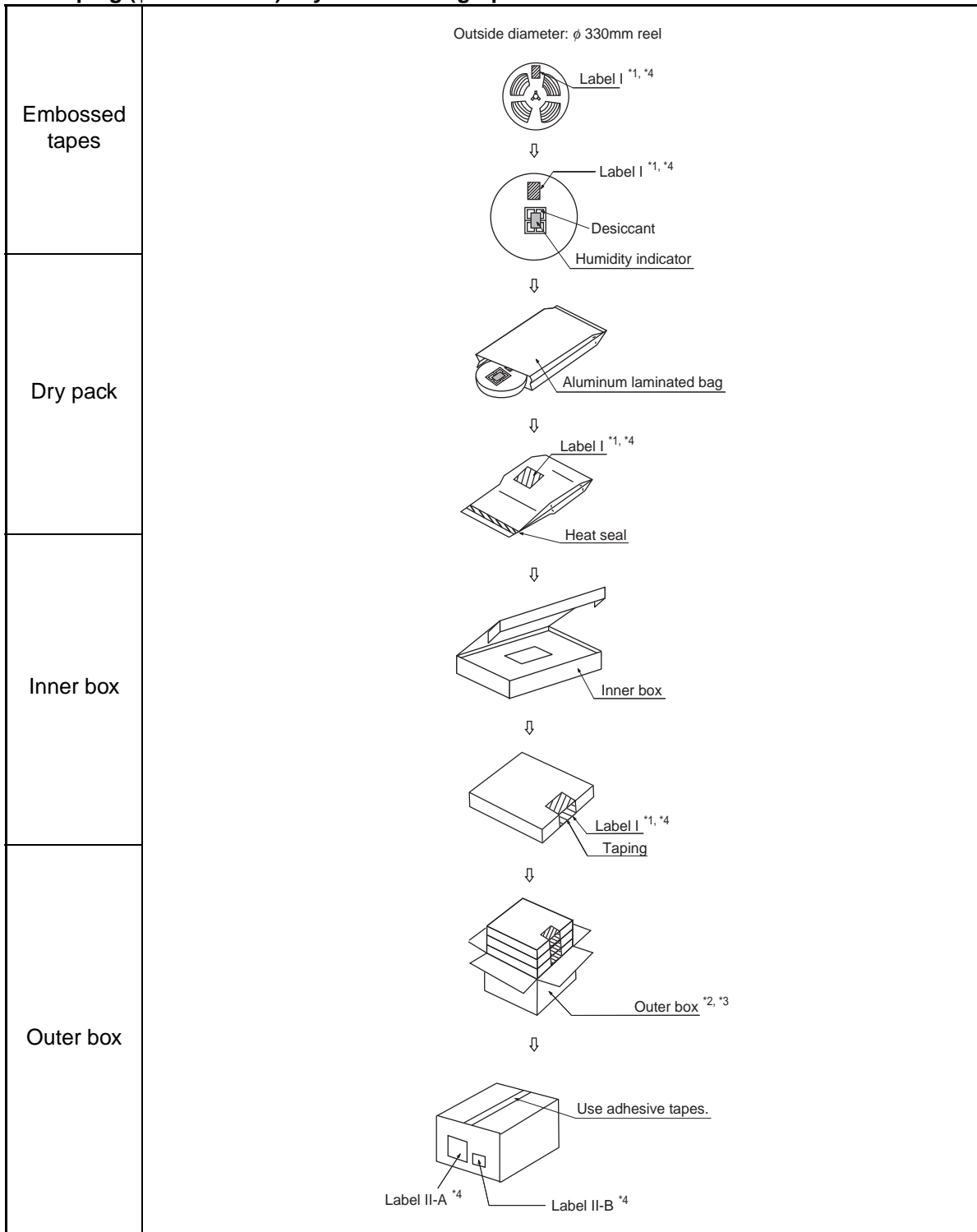

*1: For a product of which part number is suffixed with "E1", a "G" (Pb) marks is display to the moisture barrier bag and the inner boxes.

*2: The size of the outer box may be changed depending on the quantity of inner boxes.

*3: The space in the outer box will be filled with empty inner boxes, or cushions, etc.

*4: Please refer to an attached sheet about the indication label.

Note: The packing specifications may not be applied when the product is delivered via a distributor.

MB85RS64V

2.5 Product label indicators

Label I: Label on Inner box/Moisture Barrier Bag/ (It sticks it on the reel for the emboss taping)
 [C-3 Label (50mm × 100mm) Supplemental Label (20mm × 100mm)]

XXXXXXXXXXXXXXXX (Customer part number or FJ part number)	← C-3 Label
(3N)1 XXXXXXXXXXXXXXXX XXX (LEAD FREE mark) (Part number and quantity)	
XXXXXXXXXXXXXXXXXXXX (Customer part number or FJ part number) (FJ control number)	
XXX pcs (Quantity) XXXXXXXXXXXXXXXXXXXX (Customer part number or FJ part number)	
XXXXXXXXXXXXXXXXXXXX (Customer part number or FJ part number bar code)	
XXXX/XX/XX (Packed years/month/day) ASSEMBLED IN xxxx	← Perforated line
XXXXXXXXXXXXXXXXXXXX (Customer part number or FJ part number) (FJ control number bar code)	← Supplemental Label
XX/XX (Package count) XXXX-XXX XXX	
XXXXXXXXXXXX (FJ control number) (Lot Number and quantity)	
XXXXXXXXXXXXXXXXXXXX (Comment)	

Label II-A: Label on Outer box [D Label] (100mm × 100mm)

発注者 XXXXXXXXXXXXXXXX (Customer Name) (CUST.)	受注者 (VENDOR) 富士通	← D Label
受渡場所名 XXXXXXXXXXXX (Delivery Address) (DELIVERY POINT)	セミコンダクター株式会社	
納品キー番号 XXXXXXXXXXXXXXXX (TRANS.NO.) (FJ control number)	XXX (FJ control number)	
品名コード XXXXXXXXXXXXXXXX (PART NO.) (Customer part number or FJ part number)	XXX (FJ control number)	
	XXXXXXXXXXXXXXXXXXXX (Part number)	
品名 (PART NAME) XXXXXXXXXXXXXXXX (Part number)		
入数/納入数量 XXX/XXX (Q'TY/TOTAL Q'TY)	単位 XX (UNIT)	
発注者用備考 (CUSTOMER'S REMARKS) XXXXXXXXXXXXXXXXXXXX	梱包個数 (PACKAGE COUNT) XXX/XXX	
(3N)3 XXXXXXXXXXXXXXXX XXX (FJ control number + Product quantity)		
XXXXXXXXXXXXXXXXXXXX (FJ control number + Product quantity bar code)		
(3N)4 XXXXXXXXXXXXXXXX XXX (Part number + Product quantity)		
XXXXXXXXXXXXXXXXXXXX (Part number + Product quantity bar code)		
(3N)5 XXXXXXXXXXXXXXXX (FJ control number)		
XXXXXXXXXXXXXXXXXXXX (FJ control number bar code)		

Label II-B: Outer boxes product indicate

XXXXXXXXXXXXXXXXXXXX (Part number)
(Lot Number) (Count) (Quantity)
XXXX-XXX X 箱 XXX 個
XXXX-XXX X 箱 XXX 個
計 XXX 個

Note: Depending on shipment state, "Label II-A" and "Label II-B" on the external boxes might not be printed.

2.6 Dimensions for Containers

(1) Dimensions for inner box

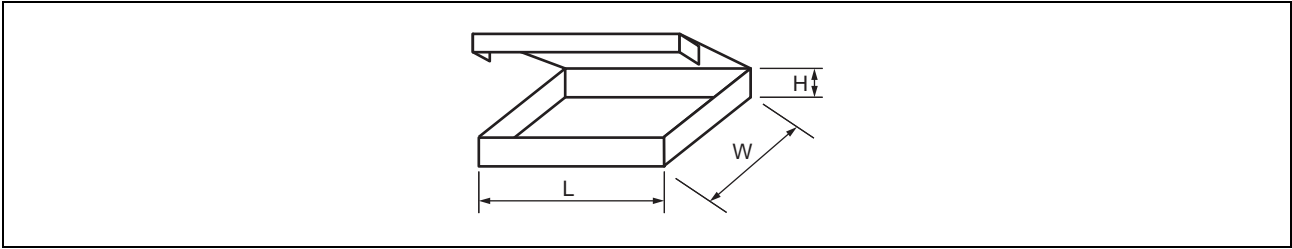

Tape width	L	W	H
12, 16	365	345	40
24, 32			50
44			65
56			75

(Dimensions in mm)

(2) Dimensions for outer box

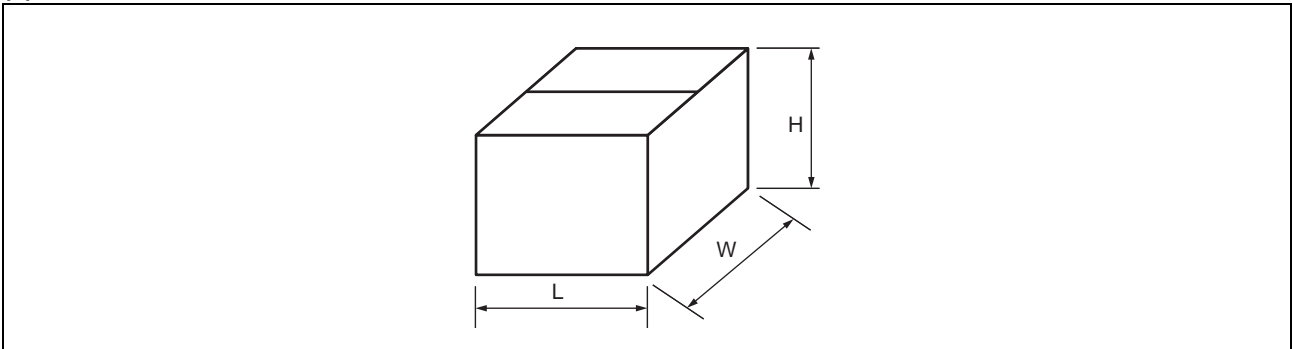

L	W	H
415	400	315

(Dimensions in mm)

■ MAJOR CHANGES IN THIS EDITION

A change on a page is indicated by a vertical line drawn on the left side of that page.

Page	Section	Change Results
1	■ FEATURES	Revised the Data retention 10 years (+ 85 °C) →10 years (+ 85 °C), 95 years (+ 55 °C), over 200 years (+ 35 °C)
12	■ ABSOLUTE MAXIMUM RATINGS	Revised the Storage Temperature - 40 °C → - 55 °C
17	■ POWER ON/OFF SEQUENCE	Deleted the following description: “Because turning the power-on from an intermediate level may cause malfunctions, when the power is turned on, V_{DD} is required to be started from 0 V.” Moved the following description under the table: “If the device does not operate within the specified conditions of read cycle, write cycle or power on/off sequence, memory data can not be guaranteed.”
	■ FRAM CHARACTERISTICS	Revised the table and Note

MEMO

MB85RS64V

FUJITSU SEMICONDUCTOR LIMITED

Nomura Fudosan Shin-yokohama Bldg. 10-23, Shin-yokohama 2-Chome,
Kohoku-ku Yokohama Kanagawa 222-0033, Japan

Tel: +81-45-415-5858

<http://jp.fujitsu.com/fsl/en/>

For further information please contact:

North and South America

FUJITSU SEMICONDUCTOR AMERICA, INC.

1250 E. Arques Avenue, M/S 333

Sunnyvale, CA 94085-5401, U.S.A.

Tel: +1-408-737-5600 Fax: +1-408-737-5999

<http://us.fujitsu.com/micro/>

Asia Pacific

FUJITSU SEMICONDUCTOR ASIA PTE. LTD.

151 Lorong Chuan,

#05-08 New Tech Park 556741 Singapore

Tel : +65-6281-0770 Fax : +65-6281-0220

<http://sg.fujitsu.com/semiconductor/>

Europe

FUJITSU SEMICONDUCTOR EUROPE GmbH

Pittlerstrasse 47, 63225 Langen, Germany

Tel: +49-6103-690-0 Fax: +49-6103-690-122

<http://emea.fujitsu.com/semiconductor/>

FUJITSU SEMICONDUCTOR SHANGHAI CO., LTD.

30F, Kerry Parkside, 1155 Fang Dian Road, Pudong District,

Shanghai 201204, China

Tel : +86-21-6146-3688 Fax : +86-21-6146-3660

<http://cn.fujitsu.com/fss/>

Korea

FUJITSU SEMICONDUCTOR KOREA LTD.

902 Kosmo Tower Building, 1002 Daechi-Dong,

Gangnam-Gu, Seoul 135-280, Republic of Korea

Tel: +82-2-3484-7100 Fax: +82-2-3484-7111

<http://kr.fujitsu.com/fsk/>

FUJITSU SEMICONDUCTOR PACIFIC ASIA LTD.

2/F, Green 18 Building, Hong Kong Science Park,

Shatin, N.T., Hong Kong

Tel : +852-2736-3232 Fax : +852-2314-4207

<http://cn.fujitsu.com/fsp/>

Specifications are subject to change without notice. For further information please contact each office.

All Rights Reserved.

The contents of this document are subject to change without notice.

Customers are advised to consult with sales representatives before ordering.

The information, such as descriptions of function and application circuit examples, in this document are presented solely for the purpose of reference to show examples of operations and uses of FUJITSU SEMICONDUCTOR device; FUJITSU SEMICONDUCTOR does not warrant proper operation of the device with respect to use based on such information. When you develop equipment incorporating the device based on such information, you must assume any responsibility arising out of such use of the information.

FUJITSU SEMICONDUCTOR assumes no liability for any damages whatsoever arising out of the use of the information.

Any information in this document, including descriptions of function and schematic diagrams, shall not be construed as license of the use or exercise of any intellectual property right, such as patent right or copyright, or any other right of FUJITSU SEMICONDUCTOR or any third party or does FUJITSU SEMICONDUCTOR warrant non-infringement of any third-party's intellectual property right or other right by using such information. FUJITSU SEMICONDUCTOR assumes no liability for any infringement of the intellectual property rights or other rights of third parties which would result from the use of information contained herein.

The products described in this document are designed, developed and manufactured as contemplated for general use, including without limitation, ordinary industrial use, general office use, personal use, and household use, but are not designed, developed and manufactured as contemplated (1) for use accompanying fatal risks or dangers that, unless extremely high safety is secured, could have a serious effect to the public, and could lead directly to death, personal injury, severe physical damage or other loss (i.e., nuclear reaction control in nuclear facility, aircraft flight control, air traffic control, mass transport control, medical life support system, missile launch control in weapon system), or (2) for use requiring extremely high reliability (i.e., submersible repeater and artificial satellite).

Please note that FUJITSU SEMICONDUCTOR will not be liable against you and/or any third party for any claims or damages arising in connection with above-mentioned uses of the products.

Any semiconductor devices have an inherent chance of failure. You must protect against injury, damage or loss from such failures by incorporating safety design measures into your facility and equipment such as redundancy, fire protection, and prevention of over-current levels and other abnormal operating conditions.

Exportation/release of any products described in this document may require necessary procedures in accordance with the regulations of the Foreign Exchange and Foreign Trade Control Law of Japan and/or US export control laws.

The company names and brand names herein are the trademarks or registered trademarks of their respective owners.

Edited: Sales Promotion Department