

## 32-bit Microcontroller

### FR Family FR81S

# MB91580L Series

**MB91F585LA/F585LB/F585LC/F585LD/  
MB91F586LA/F586LB/F586LC/F586LD/  
MB91F587LA/F587LB/F587LC/F587LD**

#### ■ DESCRIPTION

This series has Fujitsu 32-bit microcontrollers for automobile motor control. They use the FR81S CPU that is compatible with the FR family.

Note: FR, the abbreviation of FUJITSU RISC controller, is a line of products of Fujitsu Semiconductor Limited.

#### ■ FEATURES

- FR81S CPU Core
  - 32-bit RISC, load/store architecture, pipeline 5-stage structure
  - Maximum operating frequency: 128MHz (Source oscillation= 4.0MHz, 32 multiplied ( PLL clock multiplication system) )
  - General-purpose register: 32 bits, 16 sets
  - 16-bit fixed length instructions (basic instructions), 1 instruction per cycle
  - Instructions appropriate to embedded applications
    - Memory-to-memory transfer instructions
    - Bit manipulation instructions
    - Barrel shift instructions
  - High-level language support instructions
    - Function entry/exit instructions
    - Register content multi-load and store instructions
  - Bit search instructions
    - Logical 1 detection, 0 detection, and change-point detection
  - Branch instructions with delay slot
    - Overhead decrement during branch process
  - Register interlock function
    - Easy assembler writing
  - Built-in multiplier and instruction level support
    - Signed 32-bit multiplication: 5 cycles
    - Signed 16-bit multiplication: 3 cycles

FUJITSU SEMICONDUCTOR provides information facilitating product development via the following website. The website contains information useful for customers.

<http://edevicе.fujitsu.com/micom/en-support/>

# MB91580L Series

- Interrupt (PC/PS saving)
  - 6 cycles (16 priority levels)
- The Harvard architecture allows simultaneous execution of program and data access.
- Instruction compatibility with the FR family
- Built-in memory protection function (MPU)
  - Eight protection areas can be specified commonly for instructions and data.
  - Control access privilege in both privilege mode and user mode
- Built-in FPU (floating-point operation)
  - IEEE754 compliant
  - Floating-point register: 32 bits × 16 sets
- Peripheral Functions
  - Clock generation (SSCG function is available)
    - Main oscillation (4 to 20 MHz)
    - PLL multiplication rate: 1 to 32 times
  - CR oscillation
    - Oscillation frequency: 100kHz, with frequency precision ± 10%
    - Trimming is enabled
    - To be used as a count clock of hardware watchdog
    - MB91F585LC/F586LC/F587LC/F585LD/F586LD/F587LD: Oscillation stop feature during stand-by is not available
    - MB91F585LA/F586LA/F587LA/F585LB/F586LB/F587LB: Oscillation stop feature during stand-by is available
  - Built-in program flash memory capacity
    - MB91F585L: 512+64 Kbytes
    - MB91F586L: 768+64 Kbytes
    - MB91F587L: 1024+64 Kbytes
  - Built-in data flash (WorkFlash) 64 Kbytes
  - Built-in RAM capacity
    - Main RAM
      - MB91F585L: 48 Kbytes
      - MB91F586L: 64 Kbytes
      - MB91F587L: 96 Kbytes
    - Backup RAM 8 Kbytes
  - General-purpose ports:
    - MB91F585LA/F586LA/F587LA/F585LC/F586LC/F587LC 98 ports
    - MB91F585LB/F586LB/F587LB/F585LD/F586LD/F587LD 111 ports
    - Including eight I<sup>2</sup>C pseudo open drain corresponding ports
  - External bus interface (MB91F585LB/F586LB/F587LB/F585LD/F586LD/F587LD)
    - Maximum operating frequency: 40MHz
    - 22-bit address, 16-bit data
  - DMA controller
    - Up to 8 channels can be started simultaneously.
    - 2 transfer factors (Internal peripheral request and software)
  - External interrupt input: 8 channels
    - Level ("H" / "L") or edge detection (rising or falling) enabled
  - Multi-function serial communication (built-in transmission/reception FIFO memory): 5 channels < UART (Asynchronous serial interface) >
    - Full-duplex double buffering system, 64-byte transmission FIFO memory, 64-byte reception FIFO memory
    - Parity or no parity is selectable.
    - Built-in dedicated baud rate generator
    - An external clock can be used as the transfer clock
    - Parity, frame, and overrun error detection functions provided
    - DMA transfer supported

## <CSIO (Synchronous serial interface) >

- Full-duplex double buffering system, 64-byte transmission FIFO memory, 64-byte reception FIFO memory
- SPI supported; master and slave systems supported; 5 to 16, 20, 24, 32-bit data length can be set.
- Built-in dedicated baud rate generator (Master operation)
- An external clock can be entered. (Slave operation)
- Overrun error detection function is provided.
- Built-in chip selection function
- DMA transfer supported

## <LIN interface (v2.1)>

- Full-duplex double buffering system, 64-byte transmission FIFO memory, 64-byte reception FIFO memory
- LIN protocol revision 2.1 supported.
- Master and slave systems supported
- Framing error and overrun error detection
- LIN synch break generation and detection; LIN synch delimiter generation
- Built-in dedicated baud rate generator
- An external clock can be adjusted by the reload counter.
- DMA transfer supported

## <I<sup>2</sup>C >

- Supported for 4 channels: ch.0, ch.1, ch.3, and ch4.
- Full-duplex double buffering system, 64-byte transmission FIFO memory, 64-byte reception FIFO memory
- Standard mode (Max. 100 kbps) / high-speed mode (Max. 400 kbps) supported
- DMA transfer supported (for transmission only)
- CAN controller (C-CAN): 3 channels
  - Transfer speed: Up to 1Mbps
  - 64-transmission/reception message buffering: 3 channels
- FlexRay controller: 1unit(ch.A/ch.B)
  - FlexRay Specifications Version 2.1 supported
  - Up to 128 message buffers
  - 8K bytes of message RAM
  - Variable length of message buffers
  - Each message buffer can be allocated as a part of reception buffer, transmission buffer or reception FIFO memory
  - Host access to the message buffer via input and output buffers
  - Filtering for slot counter, cycle counter and channels
  - Maskable interrupts are supported
- PPG: 16 bits × 24 channels
- Reload timer: 16 bits × 4 channels
- A/D converter (successive approximation type)
  - 12-bit resolution: 3units(24 channels)
  - Conversion time: 1 μs
- Free-run timer: 16 bits × 6 channels (1 channel can be selected for input capture, and 1 channel for output compare.)
- Input capture: 16 bits × 8 channels (linked to the free-run timer)
- Output compare: 16 bits × 12 channels (linked to the free-run timer)
- Waveform generator: 2 units (12 channels)
- R/D converter: 1 channel (MB91F585LA/F586LA/F587LA/F585LC/F586LC/F587LC)
- 10-bit D/A converter: 1 channel (MB91F585LB/F586LB/F587LB/F585LD/F586LD/F587LD)
- Calibration: The hardware watchdog for CR oscillation drive  
The CR oscillation frequency can be trimmed.

# MB91580L Series

- Clock Supervisor
  - Anomaly supervisory feature (by damaged quartz, etc.) of external main oscillation (4MHz)
  - When anomaly is detected, clock is switched to CR.
- Up/ down counter: 2 channels
  - 8/16-bit Up/ down counter
- Base timer: 2 channels
  - 16-bit timer
  - Any of four PWM/PPG/PWC/reload timer functions can be selected and used.
  - A 32-bit timer can be used in 2 channels of cascade mode.
- CRC generation
- Watchdog timer
  - Hardware watchdog
  - Software watchdog
- NMI
- Interrupt controller
- Interrupt request batch read
  - Multiple interrupts from peripherals can be read by a series of registers.
- I/O relocation
  - Change of pin position of peripheral functions
- Low-power consumption mode
  - Sleep/Stop/Watch
  - Stop (Power shut-off)/Watch (Power shut-off)
- Power-on reset
- Low-voltage detection reset (external low-voltage detection)
- Low-voltage detection reset (internal low-voltage detection)
- Device package: LQFP-144
- CMOS 90 nm technology
- Power supplies
  - Single 5V power supply
  - The voltage step-down circuit brings the 5.0V down to generate 1.2V internally
  - I/O 5.0V

# MB91580L Series

## ■ PRODUCT LINEUP

### MB91580L Series Product Lineup Comparison

#### • Memory size

Items	MB91F585LA MB91F585LB MB91F585LC MB91F585LD	MB91F586LA MB91F586LB MB91F586LC MB91F586LD	MB91F587LA MB91F587LB MB91F587LC MB91F587LD
Flash memory capacity (program)	512+64 Kbytes	768+64 Kbytes	1024+64 Kbytes
Flash memory capacity (work)	64 Kbytes		
RAM capacity (main)	48 Kbytes	64 Kbytes	96 Kbytes
RAM capacity (backup)	8 Kbytes		

#### • Function

Items	MB91F585LA MB91F586LA MB91F587LA	MB91F585LB MB91F586LB MB91F587LB	MB91F585LC MB91F586LC MB91F587LC	MB91F585LD MB91F586LD MB91F587LD
System clock	On-chip PLL clock multiplication system (Up to 32 times of multiplication) Minimum instruction execution time: 7.81ns (128MHz, source oscillation 4MHz × 32 times of multiplication)			
CR oscillation	Provided			
Oscillation stop feature during stand-by	Provided	Provided	Not provided	Not provided
External bus interface	Not provided	Address: 22 bits Data: 16 bits	Not provided	Address: 22 bits Data: 16 bits
DMA transfer	8 channels			
16-bit base timer	2 channels			
Free-run timer	6 channels			
Input capture	8 channels			
Output compare	12 channels			
Waveform generator	2 units (12 channels)			
16-bit reload timer	4 channels			
PPG	24 channels			
External interrupt	8 channels			
A/D converter	3 units (24 channels)			
R/D converter	Provided	Not provided	Provided	Not provided
D/A converter	Not provided	Provided	Not provided	Provided
Up/ down counter	2 channels			
Multi-function serial interface	5 channels			
CAN	64 msb × 3 channels (ch.0/ch.1/ch.2)			
FlexRay	128 msb × 1 unit (ch.A / ch.B)			
Software watchdog	Provided			
Hardware watchdog	Provided			
CRC generation	1 channel			
Low-voltage detection reset (Internal low-voltage detection)	Provided			
Low-voltage detection reset (External low-voltage detection)	Provided			
Device package	LQFP-144			
Debug interface	Built-in OCD (On Chip Debug Unit)			

# MB91580L Series

## MB91580M Series Product Lineup Comparison

### • Memory size

Items	MB91F583MG MB91F583MH MB91F583MJ MB91F583MK	MB91F584MG MB91F584MH MB91F584MJ MB91F584MK	MB91F585MG MB91F585MH MB91F585MJ MB91F585MK
Flash memory capacity (program)	256+64 Kbytes	384+64 Kbytes	512+64 Kbytes
Flash memory capacity (work)	64 Kbytes		
RAM capacity (main)	32 Kbytes	48 Kbytes	48 Kbytes
RAM capacity (backup)	8 Kbytes		

### • Function

Items	MB91F583MG MB91F584MG MB91F585MG	MB91F583MH MB91F584MH MB91F585MH	MB91F583MJ MB91F584MJ MB91F585MJ	MB91F583MK MB91F584MK MB91F585MK
System clock	On-chip PLL clock multiplication system (Up to 32 times of multiplication) Minimum instruction execution time: 7.81ns (128MHz, source oscillation 4MHz × 32 times of multiplication)			
CR oscillation	Provided			
Oscillation stop feature during stand-by	Provided	Provided	Not provided	Not provided
External bus interface	Not provided			
DMA transfer	8 channels			
16-bit base timer	2 channels			
Free-run timer	6 channels			
Input capture	4 channels			
Output compare	7 channels			
Waveform generator	1 unit (6 channels)+1 channel			
16-bit reload timer	4 channels			
PPG	6 channels			
External interrupt	8 channels			
A/D converter	3 units (23 channels)			
R/D converter	Not provided			
D/A converter	Provided			
Up/ down counter	2 channels			
Multi-function serial interface	4 channels			
CAN	64msb × 2 channels (ch.0/ch.1)			
FlexRay	128msb × 1 unit (ch.A / ch.B)	Not provided	128msb × 1 unit (ch.A / ch.B)	Not provided
Software watchdog	Provided			
Hardware watchdog	Provided			
CRC generation	2 channels			
Low-voltage detection reset (Internal low-voltage detection)	Provided			
Low-voltage detection reset (External low-voltage detection)	Provided			
Device package	LQFP-100			
Debug interface	Built-in OCD (On Chip Debug Unit)			

Note: For details on the MB91580M series, see the "MB91580M/S Series HARDWARE MANUAL".

# MB91580L Series

## MB91580S Series Product Lineup Comparison

### • Memory size

Items	MB91F583SG MB91F583SH MB91F583SJ MB91F583SK	MB91F584SG MB91F584SH MB91F584SJ MB91F584SK	MB91F585SG MB91F585SH MB91F585SJ MB91F585SK
Flash memory capacity (program)	256+64 Kbytes	384+64 Kbytes	512+64 Kbytes
Flash memory capacity (work)	64 Kbytes		
RAM capacity (main)	32 Kbytes	48 Kbytes	48 Kbytes
RAM capacity (backup)	8 Kbytes		

### • Function

Items	MB91F583SG MB91F584SG MB91F585SG	MB91F583SH MB91F584SH MB91F585SH	MB91F583SJ MB91F584SJ MB91F585SJ	MB91F583SK MB91F584SK MB91F585SK
System clock	On-chip PLL clock multiplication system (Up to 32 times of multiplication) Minimum instruction execution time: 7.81ns (128MHz, source oscillation 4MHz × 32 times of multiplication)			
CR oscillation	Provided			
Oscillation stop feature during stand-by	Provided	Provided	Not provided	Not provided
External bus interface	Not provided			
DMA transfer	8 channels			
16-bit base timer	2 channels			
Free-run timer	6 channels			
Input capture	4 channels			
Output compare	7 channels			
Waveform generator	1 unit (6 channels)+1 channel			
16-bit reload timer	4 channels			
PPG	6 channels			
External interrupt	7 channels			
A/D converter	3 units (17 channels)			
R/D converter	Not provided			
D/A converter	Provided			
Up/ down counter	2 channels			
Multi-function serial interface	2 channels			
CAN	64msb × 1 channel (ch.0)			
FlexRay	128msb × 1unit (ch.A / ch.B)	Not provided	128msb × 1unit (ch.A / ch.B)	Not provided
Software watchdog	Provided			
Hardware watchdog	Provided			
CRC generation	2 channels			
Low-voltage detection reset (Internal low-voltage detection)	Provided			
Low-voltage detection reset (External low-voltage detection)	Provided			
Device package	LQFP-64			
Debug interface	Built-in OCD (On Chip Debug Unit)			

Note: For details on the MB91580S series, see the "MB91580M/S Series HARDWARE MANUAL".

# MB91580L Series

## ■ PIN ASSIGNMENT

- LQFP-144 Pin Assignment MB91F585LA/F586LA/F587LA/F585LC/F586LC/F587LC

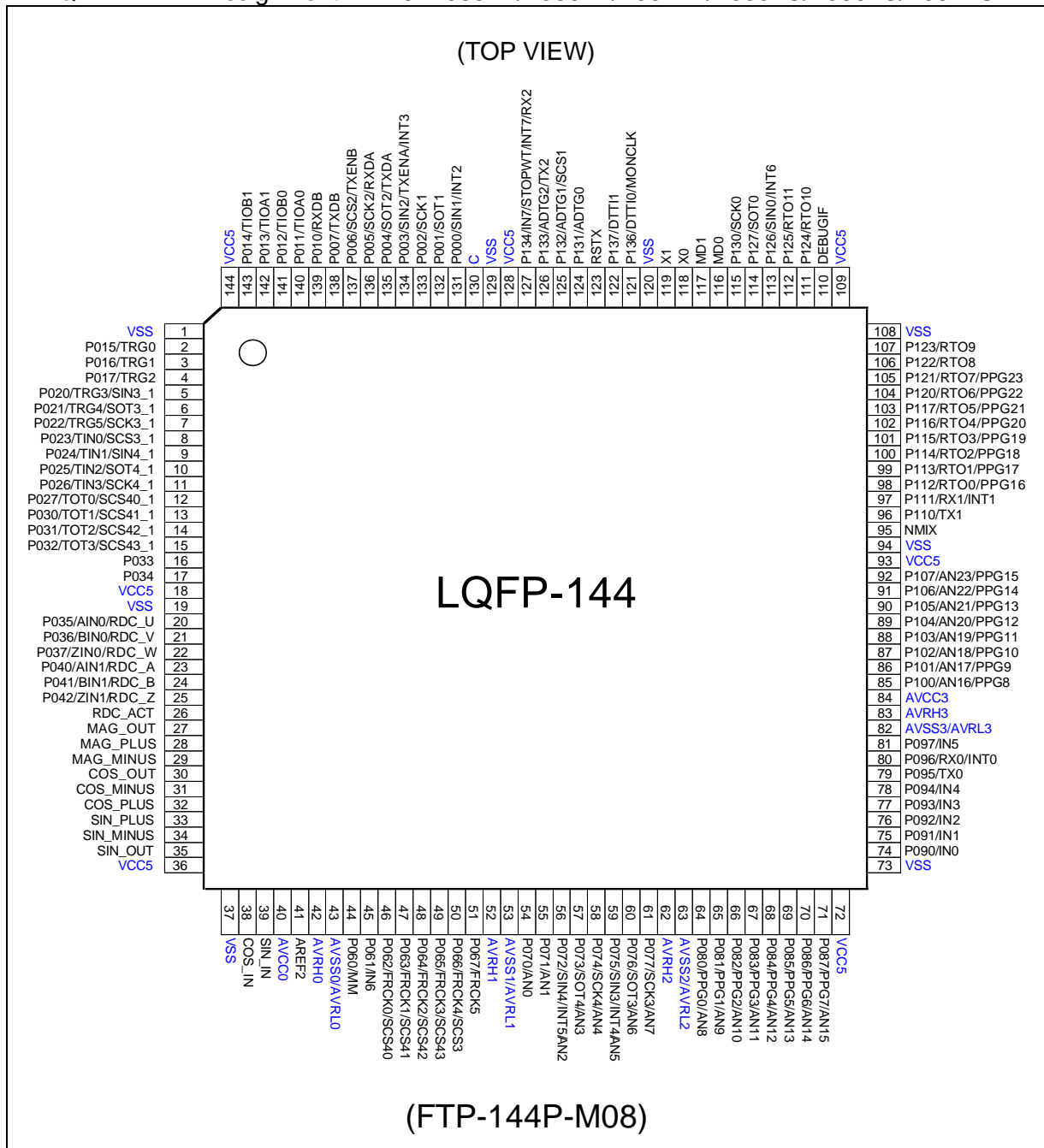



- MB91F585LB/F586LB/F587LB/F585LD/F586LD/F587LD

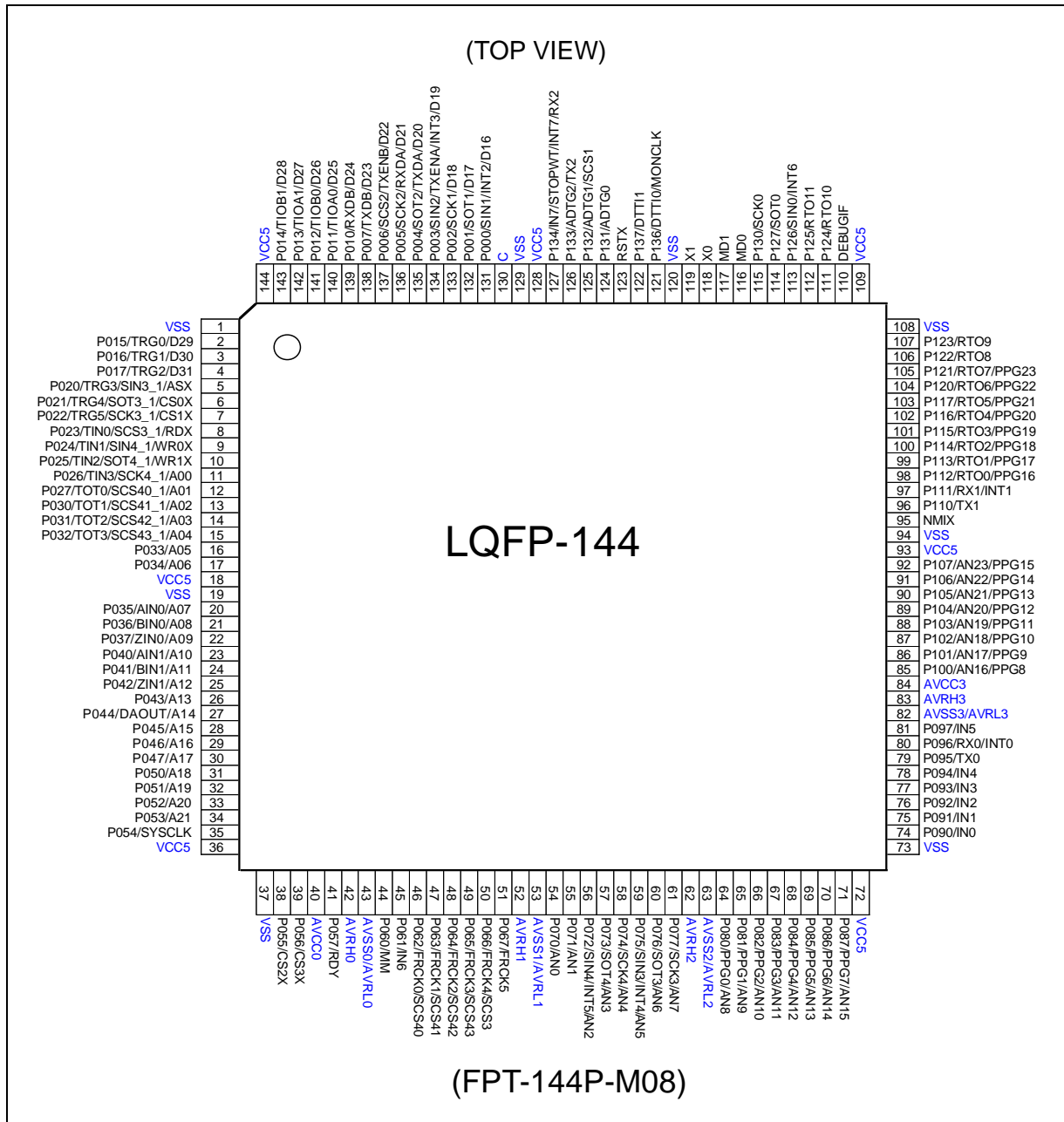

# MB91580L Series

## ■ PIN DESCRIPTION

- MB91F585LA/F586LA/F587LA/F585LC/F586LC/F587LC

Pin No.	Pin name	I/O circuit type*	Function
118	X0	A	Main clock oscillation input pin
119	X1		Main clock oscillation output pin
95	NMIX	B	Interrupt input pin without mask
123	RSTX	B	External reset input pin
116	MD0	C	Mode pin 0 (with high-voltage control)
117	MD1	C	Mode pin 1 (with high-voltage control)
131	P000	E	General-purpose I/O port
	INT2		INT2 external interrupt input pin
	SIN1		Multi-function serial ch.1 serial data input pin
132	P001	K	General-purpose I/O port
	SOT1		Multi-function serial ch.1 serial data output pin/ I <sup>2</sup> C ch.1 serial data I/O pin (SDA)
133	P002	K	General-purpose I/O port
	SCK1		Multi-function serial ch.1 clock I/O pin/ I <sup>2</sup> C ch.1 clock I/O pin (SCL)
134	P003	O	General-purpose I/O port
	TXENA		FlexRay ch.A operation enable output pin
	INT3		INT3 external interrupt input pin
	SIN2		Multi-function serial ch.2 serial data input pin
135	P004	N	General-purpose I/O port
	TXDA		FlexRay ch.A data output pin
	SOT2		Multi-function serial ch.2 serial data output pin
136	P005	N	General-purpose I/O port
	RXDA		FlexRay ch.A data input pin
	SCK2		Multi-function serial ch.2 clock I/O pin
137	P006	N	General-purpose I/O port
	TXENB		FlexRay ch.B operation enable output pin
	SCS2		Multi-function serial ch2 serial chip select I/O pin
138	P007	N	General-purpose I/O port
	TXDB		FlexRay ch.B data output pin
139	P010	N	General-purpose I/O port
	RXDB		FlexRay ch.B data input pin
140	P011	D	General-purpose I/O port
	TIOA0		Base timer ch.0 TIOA I/O pin
141	P012	D	General-purpose I/O port
	TIOB0		Base timer ch.0 TIOB I/O pin
142	P013	D	General-purpose I/O port
	TIOA1		Base timer ch.1 TIOA I/O pin
143	P014	D	General-purpose I/O port
	TIOB1		Base timer ch.1 TIOB I/O pin
2	P015	D	General-purpose I/O port
	TRG0		PPG ch.0 to ch.3 external trigger
3	P016	D	General-purpose I/O port
	TRG1		PPG ch.4 to ch.7 external trigger

# MB91580L Series

Pin No.	Pin name	I/O circuit type*	Function
4	P017	D	General-purpose I/O port
	TRG2		PPG ch.8 to ch.11 external trigger
5	P020	D	General-purpose I/O port
	TRG3		PPG ch.12 to ch.15 external trigger
	SIN3_1		Multi-function serial ch.3 serial data input pin (1)
6	P021	K	General-purpose I/O port
	TRG4		PPG16 to PPG19 external trigger
	SOT3_1		Multi-function serial ch.3 serial data output pin (1)/ I <sup>2</sup> C ch.3 serial data I/O pin (1) (SDA)
7	P022	K	General-purpose I/O port
	TRG5		PPG ch.20 to ch.23 external trigger
	SCK3_1		Multi-function serial ch.3 clock I/O pin (1)/ I <sup>2</sup> C ch.3 clock I/O pin (1) (SCL)
8	P023	D	General-purpose I/O port
	TIN0		Reload timer ch.0 event input pin
	SCS3_1		Multi-function serial ch.3 serial chip select I/O pin (1)
9	P024	D	General-purpose I/O port
	TIN1		Reload timer ch.1 event input pin
	SIN4_1		Multi-function serial ch.4 serial data input pin (1)
10	P025	K	General-purpose I/O port
	TIN2		Reload timer ch.2 event input pin
	SOT4_1		Multi-function serial ch.4 serial data output pin (1)/ I <sup>2</sup> C ch.4 serial data I/O pin (1) (SDA)
11	P026	K	General-purpose I/O port
	TIN3		Reload timer ch.3 event input pin
	SCK4_1		Multi-function serial ch.4 clock I/O pin (1)/ I <sup>2</sup> C ch.4 clock I/O pin (1) (SCL)
12	P027	D	General-purpose I/O port
	TOT0		Reload timer ch.0 output pin
	SCS40_1		Multi-function serial ch.4 serial chip select 0 I/O pin (1)
13	P030	D	General-purpose I/O port
	TOT1		Reload timer ch.1 output pin
	SCS41_1		Multi-function serial ch.4 serial chip select 1 output pin (1)
14	P031	D	General-purpose I/O port
	TOT2		Reload timer ch.2 output pin
	SCS42_1		Multi-function serial ch.4 serial chip select 2 output pin (1)
15	P032	D	General-purpose I/O port
	TOT3		Reload timer ch.3 output pin
	SCS43_1		Multi-function serial ch.4 serial chip select 3 output pin (1)
16	P033	D	General-purpose I/O port
17	P034	D	General-purpose I/O port
20	P035	D	General-purpose I/O port
	AIN0		Up/ down counter ch.0 AIN input pin
	RDC_U		RDC phase U output pin
21	P036	D	General-purpose I/O port
	BIN0		Up/ down counter ch.0 BIN input pin
	RDC_V		RDC phase V output pin

# MB91580L Series

Pin No.	Pin name	I/O circuit type*	Function
22	P037	D	General-purpose I/O port
	ZIN0		Up/ down counter ch.0 ZIN input pin
	RDC_W		RDC phase W output pin
23	P040	D	General-purpose I/O port
	AIN1		Up/ down counter ch.1 AIN input pin
	RDC_A		RDC phase A output pin
24	P041	D	General-purpose I/O port
	BIN1		Up/ down counter ch.1 BIN input pin
	RDC_B		RDC phase B output pin
25	P042	D	General-purpose I/O port
	ZIN1		Up/ down counter ch.1 ZIN input pin
	RDC_Z		RDC phase Z output pin
26	RDC_ACT	J	RDC operation status output pin
27	MAG_OUT	I	RDC excitation signal output pin
28	MAG_PLUS	H	RDC excitation external input pin +
29	MAG_MINUS	H	RDC excitation external input pin -
30	COS_OUT	I	RDC COS output pin
31	COS_MINUS	H	RDC COS input pin -
32	COS_PLUS	H	RDC COS input pin +
33	SIN_PLUS	H	RDC SIN input pin +
34	SIN_MINUS	H	RDC SIN input pin -
35	SIN_OUT	I	RDC SIN output pin
38	COS_IN	H	RDC COS coil earth leakage detection input pin
39	SIN_IN	H	RDC SIN coil earth leakage detection input pin
41	AREF2	I	RDC Aref output (AVcc0/2) pin
44	P060	D	General-purpose I/O port
	MM		Clock supervisor main clock missing output pin
45	P061	D	General-purpose I/O port
	IN6		16-bit input capture ch.6 external pulse input pin
46	P062	D	General-purpose I/O port
	FRCK0		Free-run timer ch.0 external clock input pin
	SCS40		Multi-function serial ch.4 serial chip select 0 I/O pin
47	P063	D	General-purpose I/O port
	FRCK1		Free-run timer ch.1 external clock input pin
	SCS41		Multi-function serial ch.4 serial chip select 1 output pin
48	P064	D	General-purpose I/O port
	FRCK2		Free-run timer ch.2 external clock input pin
	SCS42		Multi-function serial ch.4 serial chip select 2 output pin
49	P065	D	General-purpose I/O port
	FRCK3		Free-run timer ch.3 external clock input pin
	SCS43		Multi-function serial ch.4 serial chip select 3 output pin
50	P066	D	General-purpose I/O port
	FRCK4		Free-run timer ch.4 external clock input pin
	SCS3		Multi-function serial ch.3 serial chip select I/O pin
51	P067	D	General-purpose I/O port
	FRCK5		Free-run timer ch.5 external clock input pin

# MB91580L Series

Pin No.	Pin name	I/O circuit type*	Function
54	P070	F	General-purpose I/O port
	AN0		ADC analog 0 input pin
55	P071	F	General-purpose I/O port
	AN1		ADC analog 1 input pin
56	P072	G	General-purpose I/O port
	AN2		ADC analog 2 input pin
	SIN4		Multi-function serial ch.4 serial data input pin
	INT5		INT5 external interrupt input pin
57	P073	M	General-purpose I/O port
	AN3		ADC analog 3 input pin
	SOT4		Multi-function serial ch.4 serial data output pin/ I <sup>2</sup> C ch.4 serial data I/O pin (SDA)
58	P074	M	General-purpose I/O port
	AN4		ADC analog 4 input pin
	SCK4		Multi-function serial ch.4 clock I/O pin/ I <sup>2</sup> C ch.4 clock I/O pin (SCL)
59	P075	G	General-purpose I/O port
	AN5		ADC analog 5 input pin
	SIN3		Multi-function serial ch.3 serial data input pin
	INT4		INT4 external interrupt input pin
60	P076	M	General-purpose I/O port
	AN6		ADC analog 6 input pin
	SOT3		Multi-function serial ch.3 serial data output pin/ I <sup>2</sup> C ch.3 serial data I/O pin (SDA)
61	P077	M	General-purpose I/O port
	AN7		ADC analog 7 input pin
	SCK3		Multi-function serial ch.3 clock I/O pin / I <sup>2</sup> C ch.3 clock I/O pin (SCL)
64	P080	F	General-purpose I/O port
	AN8		ADC analog 8 input pin
	PPG0		PPG ch.0 output pin
65	P081	F	General-purpose I/O port
	AN9		ADC analog 9 input pin
	PPG1		PPG ch.1 output pin
66	P082	F	General-purpose I/O port
	AN10		ADC analog 10 input pin
	PPG2		PPG ch.2 output pin
67	P083	F	General-purpose I/O port
	AN11		ADC analog 11 input pin
	PPG3		PPG ch.3 output pin
68	P084	F	General-purpose I/O port
	AN12		ADC analog 12 input pin
	PPG4		PPG ch.4 output pin
69	P085	F	General-purpose I/O port
	AN13		ADC analog 13 input pin
	PPG5		PPG ch.5 output pin

# MB91580L Series

Pin No.	Pin name	I/O circuit type*	Function
70	P086	F	General-purpose I/O port
	AN14		ADC analog 14 input pin
	PPG6		PPG ch.6 output pin
71	P087	F	General-purpose I/O port
	AN15		ADC analog 15 input pin
	PPG7		PPG ch.7 output pin
74	P090	D	General-purpose I/O port
	IN0		16-bit input capture ch.0 external pulse input pin
75	P091	D	General-purpose I/O port
	IN1		16-bit input capture ch.1 external pulse input pin
76	P092	D	General-purpose I/O port
	IN2		16-bit input capture ch.2 external pulse input pin
77	P093	D	General-purpose I/O port
	IN3		16-bit input capture ch.3 external pulse input pin
78	P094	D	General-purpose I/O port
	IN4		16-bit input capture ch.4 external pulse input pin
79	P095	D	General-purpose I/O port
	TX0		CAN transmission data 0 output pin
80	P096	E	General-purpose I/O port
	RX0		CAN reception data 0 input pin
	INT0		INT0 external interrupt input pin
81	P097	D	General-purpose I/O port
	IN5		16-bit input capture ch.5 external pulse input pin
85	P100	F	General-purpose I/O port
	PPG8		PPG ch.8 output pin
	AN16		ADC analog 16 input pin
86	P101	F	General-purpose I/O port
	PPG9		PPG ch.9 output pin
	AN17		ADC analog 17 input pin
87	P102	F	General-purpose I/O port
	PPG10		PPG ch.10 output pin
	AN18		ADC analog 18 input pin
88	P103	F	General-purpose I/O port
	PPG11		PPG ch.11 output pin
	AN19		ADC analog 19 input pin
89	P104	F	General-purpose I/O port
	PPG12		PPG ch.12 output pin
	AN20		ADC analog 20 input pin
90	P105	F	General-purpose I/O port
	PPG13		PPG ch.13 output pin
	AN21		ADC analog 21 input pin
91	P106	F	General-purpose I/O port
	PPG14		PPG ch.14 output pin
	AN22		ADC analog 22 input pin
92	P107	F	General-purpose I/O port
	PPG15		PPG ch.15 output pin
	AN23		ADC analog 23 input pin

# MB91580L Series

Pin No.	Pin name	I/O circuit type*	Function
96	P110	D	General-purpose I/O port
	TX1		CAN transmission data 1 output pin
97	P111	E	General-purpose I/O port
	RX1		CAN reception data 1 input pin
	INT1		INT1 external interrupt input pin
98	P112	D	General-purpose I/O port
	RTO0		Waveform generator ch.0 output pin
	PPG16		PPG ch.16 output pin
99	P113	D	General-purpose I/O port
	RTO1		Waveform generator ch.1 output pin
	PPG17		PPG ch.17 output pin
100	P114	D	General-purpose I/O port
	RTO2		Waveform generator ch.2 output pin
	PPG18		PPG ch.18 output pin
101	P115	D	General-purpose I/O port
	RTO3		Waveform generator ch.3 output pin
	PPG19		PPG ch.19 output pin
102	P116	D	General-purpose I/O port
	RTO4		Waveform generator ch.4 output pin
	PPG20		PPG ch.20 output pin
103	P117	D	General-purpose I/O port
	RTO5		Waveform generator ch.5 output pin
	PPG21		PPG ch.21 output pin
104	P120	D	General-purpose I/O port
	RTO6		Waveform generator ch.6 output pin
	PPG22		PPG ch.22 output pin
105	P121	D	General-purpose I/O port
	RTO7		Waveform generator ch.7 output pin
	PPG23		PPG ch.23 output pin
106	P122	D	General-purpose I/O port
	RTO8		Waveform generator ch.8 output pin
107	P123	D	General-purpose I/O port
	RTO9		Waveform generator ch.9 output pin
111	P124	D	General-purpose I/O port
	RTO10		Waveform generator ch.10 output pin
112	P125	D	General-purpose I/O port
	RTO11		Waveform generator ch.11 output pin
113	P126	E	General-purpose I/O port
	SIN0		Multi-function serial ch.0 serial data input pin
	INT6		INT6 external interrupt input pin
114	P127	K	General-purpose I/O port
	SOT0		Multi-function serial ch.0 serial data output pin/ I <sup>2</sup> C ch.0 serial data I/O pin (SDA)
115	P130	K	General-purpose I/O port
	SCK0		Multi-function serial ch.0 clock I/O pin/ I <sup>2</sup> C ch.0 clock I/O pin (SCL)

# MB91580L Series

Pin No.	Pin name	I/O circuit type*	Function
124	P131	D	General-purpose I/O port
	ADTG0		A/D converter ch.0 to ch.7 external trigger input pin
125	P132	D	General-purpose I/O port
	ADTG1		A/D converter ch.8 to ch.15 external trigger input pin
	SCS1		Multi-function serial ch.1 serial chip select I/O pin
126	P133	D	General-purpose I/O port
	ADTG2		A/D converter ch.16 to ch.23 external trigger input pin
	TX2		CAN transmission data 2 output pin
127	P134	E	General-purpose I/O port
	STOPWT		FlexRay Stopwatch input pin
	RX2		CAN reception data 2 input pin
	INT7		INT7 external interrupt input pin
	IN7		16-bit input capture ch.7 external pulse input pin
110	DEBUGIF	L	DEBUG I/F pin
121	P136	D	General-purpose I/O port
	DTTI0		Waveform generator output stop signal input pin 0
	MONCLK		Clock monitor output pin
122	P137	D	General-purpose I/O port
	DTTI1		Waveform generator output stop signal input pin 1
40	AVCC0	-	R/D converter power supply
84	AVCC3	-	A/D converter analog power supply
42	AVRH0	-	R/D converter upper limit reference voltage power supply
52	AVRH1	-	A/D converter upper limit reference voltage
62	AVRH2	-	A/D converter upper limit reference voltage
83	AVRH3	-	A/D converter upper limit reference voltage
43	AVSS0	-	R/D converter GND
	AVRL0		R/D converter lower limit reference voltage
53	AVSS1	-	A/D converter GND
	AVRL1		A/D converter lower limit reference voltage
63	AVSS2	-	A/D converter GND
	AVRL2		A/D converter lower limit reference voltage
82	AVSS3	-	A/D converter GND
	AVRL3		A/D converter lower limit reference voltage
130	C	-	External capacity connection output
18, 36, 93, 72, 109, 128, 144	VCC5	-	+5.0V power supply
1, 19, 37, 73, 94, 108, 120, 129	VSS	-	GND

\*: For the I/O circuit types, see "■ I/O circuit type".



# MB91580L Series

• MB91F585LB/F586LB/F587LB/F585LD/F586LD/F587LD

Pin No.	Pin name	I/O circuit type <sup>*1</sup>	Function
118	X0	A	Main clock oscillation input pin
119	X1		Main clock oscillation output pin
95	NMIX	B	Interrupt input pin without mask
123	RSTX	B	External reset input pin
116	MD0	C	Mode pin 0 (with high-voltage control)
117	MD1	C	Mode pin 1 (with high-voltage control)
131	P000	E	General-purpose I/O port
	D16		External bus data bit16 I/O pin
	INT2		INT2 external interrupt input pin
	SIN1		Multi-function serial ch.1 serial data input pin
132	P001	K	General-purpose I/O port
	D17		External bus data bit17 I/O pin
	SOT1		Multi-function serial ch.1 serial data output pin/ I <sup>2</sup> C ch.1 serial data I/O pin (SDA)
133	P002	K	General-purpose I/O port
	D18		External bus data bit18 I/O pin
	SCK1		Multi-function serial ch.1 clock I/O pin / I <sup>2</sup> C ch.1 clock I/O pin (SCL)
134	P003	O	General-purpose I/O port
	D19		External bus data bit19 I/O pin
	TXENA		FlexRay ch.A operation enable output pin
	INT3		INT3 external interrupt input pin
	SIN2		Multi-function serial ch.2 serial data input pin
135	P004	N	General-purpose I/O port
	D20		External bus data bit20 I/O pin
	TXDA		FlexRay ch.A data output pin
	SOT2		Multi-function serial ch.2 serial data output pin
136	P005	N	General-purpose I/O port
	D21		External bus data bit21 I/O pin
	RXDA		FlexRay ch.A data input pin
	SCK2		Multi-function serial ch.2 clock I/O pin
137	P006	N	General-purpose I/O port
	D22		External bus data bit22 I/O pin
	TXENB		FlexRay ch.B operation enable output pin
	SCS2		Multi-function serial ch.2 serial chip select I/O pin
138	P007	N	General-purpose I/O port
	D23		External bus data bit23 I/O pin
	TXDB		FlexRay ch.B data output pin
139	P010	N	General-purpose I/O port
	D24		External bus data bit24 I/O pin
	RXDB		FlexRay ch.B data input pin
140	P011	D	General-purpose I/O port
	D25		External bus data bit25 I/O pin
	TIOA0		Base timer ch.0 TIOA I/O pin

# MB91580L Series

Pin No.	Pin name	I/O circuit type <sup>*1</sup>	Function
141	P012	D	General-purpose I/O port
	D26		External bus data bit26 I/O pin
	TIOB0		Base timer ch.0 TIOB I/O pin
142	P013	D	General-purpose I/O port
	D27		External bus data bit27 I/O pin
	TIOA1		Base timer ch.1 TIOA I/O pin
143	P014	D	General-purpose I/O port
	D28		External bus data bit28 I/O pin
	TIOB1		Base timer ch.1 TIOB I/O pin
2	P015	D	General-purpose I/O port
	D29		External bus data bit29 I/O pin
	TRG0		PPG ch.0 to ch.3 external trigger
3	P016	D	General-purpose I/O port
	D30		External bus data bit30 I/O pin
	TRG1		PPG ch.4 to ch.7 external trigger
4	P017	D	General-purpose I/O port
	D31		External bus data bit31 I/O pin
	TRG2		PPG ch.8 to ch.11 external trigger
5	P020	D	General-purpose I/O port
	ASX		External bus address strobe output pin
	TRG3		PPG ch.12 to ch.15 external trigger
	SIN3_1		Multi-function serial ch.3 serial data input pin (1)
6	P021	K	General-purpose I/O port
	CS0X		External bus chip select 0 output pin
	TRG4		PPG16 to PPG19 external trigger
	SOT3_1		Multi-function serial ch.3 serial data output pin (1)/ I <sup>2</sup> C ch.3 serial data I/O pin (1) (SDA)
7	P022	K	General-purpose I/O port
	CS1X		External bus chip select 1 output pin
	TRG5		PPG ch.20 to ch.23 external trigger
	SCK3_1		Multi-function serial ch.3 clock I/O pin (1)/ I <sup>2</sup> C ch.3 clock I/O pin (1) (SCL)
8	P023	D	General-purpose I/O port
	RDX		External bus read strobe output pin
	TIN0		Reload timer ch.0 event input pin
	SCS3_1		Multi-function serial ch.3 serial chip select I/O pin (1)
9	P024	D	General-purpose I/O port
	WR0X		External bus write strobe 0 output pin
	TIN1		Reload timer ch.1 event input pin
	SIN4_1		Multi-function serial ch.4 serial data input pin (1)
10	P025	K	General-purpose I/O port
	WR1X		External bus write strobe 1 output pin
	TIN2		Reload timer ch.2 event input pin
	SOT4_1		Multi-function serial ch.4 serial data output pin (1)/ I <sup>2</sup> C ch.4 serial data I/O pin (1) (SDA)

Pin No.	Pin name	I/O circuit type <sup>*1</sup>	Function
11	P026	K	General-purpose I/O port
	A00		External bus address bit0 output pin
	TIN3		Reload timer ch.3 event input pin
	SCK4_1		Multi-function serial ch.4 clock I/O pin (1)/ I <sup>2</sup> C ch.4 clock I/O pin (1) (SCL)
12	P027	D	General-purpose I/O port
	A01		External bus address bit1 output pin
	TOT0		Reload timer ch.0 output pin
	SCS40_1		Multi-function serial ch.4 serial chip select 0 I/O pin (1)
13	P030	D	General-purpose I/O port
	A02		External bus address bit2 output pin
	TOT1		Reload timer ch.1 output pin
	SCS41_1		Multi-function serial ch.4 serial chip select 1 output pin (1)
14	P031	D	General-purpose I/O port
	A03		External bus address bit3 output pin
	TOT2		Reload timer ch.2 output pin
	SCS42_1		Multi-function serial ch.4 serial chip select 2 output pin (1)
15	P032	D	General-purpose I/O port
	A04		External bus address bit4 output pin
	TOT3		Reload timer ch.3 output pin
	SCS43_1		Multi-function serial ch.4 serial chip select 3 output pin (1)
16	P033	D	General-purpose I/O port
	A05		External bus address bit5 output pin
17	P034	D	General-purpose I/O port
	A06		External bus address bit6 output pin
20	P035	D	General-purpose I/O port
	A07		External bus address bit7 output pin
	AIN0		Up/ down counter ch.0 AIN input pin
21	P036	D	General-purpose I/O port
	A08		External bus address bit8 output pin
	BIN0		Up/ down counter ch.0 BIN input pin
22	P037	D	General-purpose I/O port
	A09		External bus address bit9 output pin
	ZIN0		Up/ down counter ch.0 ZIN input pin
23	P040	D	General-purpose I/O port
	A10		External bus address bit10 output pin
	AIN1		Up/ down counter ch.1 AIN input pin
24	P041	D	General-purpose I/O port
	A11		External bus address bit11 output pin
	BIN1		Up/ down counter ch.1 BIN input pin
25	P042	D	General-purpose I/O port
	A12		External bus address bit12 output pin
	ZIN1		Up/ down counter ch.1 ZIN input pin
26	P043	D	General-purpose I/O port
	A13		External bus address bit13 output pin

# MB91580L Series

Pin No.	Pin name	I/O circuit type <sup>*1</sup>	Function
27	P044	P	General-purpose I/O port
	A14		External bus address bit14 output pin
	DAOUT		DAC analog output pin
28	P045	D	General-purpose I/O port
	A15		External bus address bit15 output pin
29	P046	D	General-purpose I/O port
	A16		External bus address bit16 output pin
30	P047	D	General-purpose I/O port
	A17		External bus address bit17 output pin
31	P050	D	General-purpose I/O port
	A18		External bus address bit18 output pin
32	P051	D	General-purpose I/O port
	A19		External bus address bit19 output pin
33	P052	D	General-purpose I/O port
	A20		External bus address bit20 output pin
34	P053	D	General-purpose I/O port
	A21		External bus address bit21 output pin
35	P054	D	General-purpose I/O port
	SYSCCLK		External bus system clock output pin
38	P055	D	General-purpose I/O port
	CS2X		External bus chip select 2 output pin
39	P056	D	General-purpose I/O port
	CS3X		External bus chip select 3 output pin
41	P057	D	General-purpose I/O port
	RDY		External bus ready input pin
44	P060	D	General-purpose I/O port
	MM		Clock supervisor main clock missing output pin
45	P061	D	General-purpose I/O port
	IN6		16-bit input capture ch.6 external pulse input pin
46	P062	D	General-purpose I/O port
	FRCK0		Free-run timer ch.0 external clock input pin
	SCS40		Multi-function serial ch.4 serial chip select 0 I/O pin
47	P063	D	General-purpose I/O port
	FRCK1		Free-run timer ch.1 external clock input pin
	SCS41		Multi-function serial ch.4 serial chip select 1 output pin
48	P064	D	General-purpose I/O port
	FRCK2		Free-run timer ch.2 external clock input pin
	SCS42		Multi-function serial ch.4 serial chip select 2 output pin
49	P065	D	General-purpose I/O port
	FRCK3		Free-run timer ch.3 external clock input pin
	SCS43		Multi-function serial ch.4 serial chip select 3 output pin
50	P066	D	General-purpose I/O port
	FRCK4		Free-run timer ch.4 external clock input pin
	SCS3		Multi-function serial ch.3 serial chip select I/O pin
51	P067	D	General-purpose I/O port
	FRCK5		Free-run timer ch.5 external clock input pin

Pin No.	Pin name	I/O circuit type <sup>*1</sup>	Function
54	P070	F	General-purpose I/O port
	AN0		ADC analog 0 input pin
55	P071	F	General-purpose I/O port
	AN1		ADC analog 1 input pin
56	P072	G	General-purpose I/O port
	AN2		ADC analog 2 input pin
	SIN4		Multi-function serial ch.4 serial data input pin
	INT5		INT5 external interrupt input pin
57	P073	M	General-purpose I/O port
	AN3		ADC analog 3 input pin
	SOT4		Multi-function serial ch.4 serial data output pin I <sup>2</sup> C ch.4 serial data I/O pin (SDA)
58	P074	M	General-purpose I/O port
	AN4		ADC analog 4 input pin
	SCK4		Multi-function serial ch.4 clock I/O / I <sup>2</sup> C ch.4 clock I/O pin (SCL)
59	P075	G	General-purpose I/O port
	AN5		ADC analog 5 input pin
	SIN3		Multi-function serial ch.3 serial data input pin
	INT4		INT4 external interrupt input pin
60	P076	M	General-purpose I/O port
	AN6		ADC analog 6 input pin
	SOT3		Multi-function serial ch.3 serial data output pin / I <sup>2</sup> C ch.3 serial data I/O pin (SDA)
61	P077	M	General-purpose I/O port
	AN7		ADC analog 7 input pin
	SCK3		Multi-function serial ch.3 clock I/O pin / I <sup>2</sup> C ch.3 clock I/O pin (SCL)
64	P080	F	General-purpose I/O port
	AN8		ADC analog 8 input pin
	PPG0		PPG ch.0 output pin
65	P081	F	General-purpose I/O port
	AN9		ADC analog 9 input pin
	PPG1		PPG ch.1 output pin
66	P082	F	General-purpose I/O port
	AN10		ADC analog 10 input pin
	PPG2		PPG ch.2 output pin
67	P083	F	General-purpose I/O port
	AN11		ADC analog 11 input pin
	PPG3		PPG ch.3 output pin
68	P084	F	General-purpose I/O port
	AN12		ADC analog 12 input pin
	PPG4		PPG ch.4 output pin
69	P085	F	General-purpose I/O port
	AN13		ADC analog 13 input pin
	PPG5		PPG ch.5 output pin

# MB91580L Series

Pin No.	Pin name	I/O circuit type <sup>*1</sup>	Function
70	P086	F	General-purpose I/O port
	AN14		ADC analog 14 input pin
	PPG6		PPG ch.6 output pin
71	P087	F	General-purpose I/O port
	AN15		ADC analog 15 input pin
	PPG7		PPG ch.7 output pin
74	P090	D	General-purpose I/O port
	IN0		16-bit input capture ch.0 external pulse input pin
75	P091	D	General-purpose I/O port
	IN1		16-bit input capture ch.1 external pulse input pin
76	P092	D	General-purpose I/O port
	IN2		16-bit input capture ch.2 external pulse input pin
77	P093	D	General-purpose I/O port
	IN3		16-bit input capture ch.3 external pulse input pin
78	P094	D	General-purpose I/O port
	IN4		16-bit input capture ch.4 external pulse input pin
79	P095	D	General-purpose I/O port
	TX0		CAN transmission data 0 output pin
80	P096	E	General-purpose I/O port
	RX0		CAN reception data 0 input pin
	INT0		INT0 external interrupt input pin
81	P097	D	General-purpose I/O port
	IN5		16-bit input capture ch.5 external pulse input pin
85	P100	F	General-purpose I/O port
	PPG8		PPG ch.8 output pin
	AN16		ADC analog 16 input pin
86	P101	F	General-purpose I/O port
	PPG9		PPG ch.9 output pin
	AN17		ADC analog 17 input pin
87	P102	F	General-purpose I/O port
	PPG10		PPG ch.10 output pin
	AN18		ADC analog 18 input pin
88	P103	F	General-purpose I/O port
	PPG11		PPG ch.11 output pin
	AN19		ADC analog 19 input pin
89	P104	F	General-purpose I/O port
	PPG12		PPG ch.12 output pin
	AN20		ADC analog 20 input pin
90	P105	F	General-purpose I/O port
	PPG13		PPG ch.13 output pin
	AN21		ADC analog 21 input pin
91	P106	F	General-purpose I/O port
	PPG14		PPG ch.14 output pin
	AN22		ADC analog 22 input pin
92	P107	F	General-purpose I/O port
	PPG15		PPG ch.15 output pin
	AN23		ADC analog 23 input pin

# MB91580L Series

Pin No.	Pin name	I/O circuit type*1	Function
96	P110	D	General-purpose I/O port
	TX1		CAN transmission data 1 output pin
97	P111	E	General-purpose I/O port
	RX1		CAN reception data 1 input pin
	INT1		INT1 external interrupt input pin
98	P112	D	General-purpose I/O port
	RTO0		Waveform generator ch.0 output pin
	PPG16		PPG ch.16 output pin
99	P113	D	General-purpose I/O port
	RTO1		Waveform generator ch.1 output pin
	PPG17		PPG ch.17 output pin
100	P114	D	General-purpose I/O port
	RTO2		Waveform generator ch.2 output pin
	PPG18		PPG ch.18 output pin
101	P115	D	General-purpose I/O port
	RTO3		Waveform generator ch.3 output pin
	PPG19		PPG ch.19 output pin
102	P116	D	General-purpose I/O port
	RTO4		Waveform generator ch.4 output pin
	PPG20		PPG ch.20 output pin
103	P117	D	General-purpose I/O port
	RTO5		Waveform generator ch.5 output pin
	PPG21		PPG ch.21 output pin
104	P120	D	General-purpose I/O port
	RTO6		Waveform generator ch.6 output pin
	PPG22		PPG ch.22 output pin
105	P121	D	General-purpose I/O port
	RTO7		Waveform generator ch.7 output pin
	PPG23		PPG ch.23 output pin
106	P122	D	General-purpose I/O port
	RTO8		Waveform generator ch.8 output pin
107	P123	D	General-purpose I/O port
	RTO9		Waveform generator ch.9 output pin
111	P124	D	General-purpose I/O port
	RTO10		Waveform generator ch.10 output pin
112	P125	D	General-purpose I/O port
	RTO11		Waveform generator ch.11 output pin
113	P126	E	General-purpose I/O port
	SIN0		Multi-function serial ch.0 serial data input pin
	INT6		INT6 external interrupt input pin
114	P127	K	General-purpose I/O port
	SOT0		Multi-function serial ch.0 serial data output pin/ I <sup>2</sup> C ch.0 serial data I/O pin (SDA)
115	P130	K	General-purpose I/O port
	SCK0		Multi-function serial ch.0 clock I/O pin/ I <sup>2</sup> C ch.0 clock I/O pin (SCL)

# MB91580L Series

Pin No.	Pin name	I/O circuit type <sup>*1</sup>	Function
124	P131	D	General-purpose I/O port
	ADTG0		A/D converter ch.0 to ch.7 external trigger input pin
125	P132	D	General-purpose I/O port
	ADTG1		A/D converter ch.8 to ch.15 external trigger input pin
	SCS1		Multi-function serial ch.1 serial chip select I/O pin
126	P133	D	General-purpose I/O port
	ADTG2		A/D converter ch.16 to ch.23 external trigger input pin
	TX2		CAN transmission data 2 output pin
127	P134	E	General-purpose I/O port
	STOPWT		FlexRay Stopwatch input pin
	RX2		CAN reception data 2 input pin
	INT7		INT7 external interrupt input pin
	IN7		16-bit input capture ch.7 external pulse input pin
110	DEBUGIF	L	DEBUG I/F pin
121	P136	D	General-purpose I/O port
	DTTI0		Waveform generator output stop signal input pin 0
	MONCLK		Clock monitor output pin
122	P137	D	General-purpose I/O port
	DTTI1		Waveform generator output stop signal input pin 1
40	AVCC0	-	*2
84	AVCC3	-	A/D converter analog power supply
42	AVRH0	-	*2
52	AVRH1	-	A/D converter upper limit reference voltage
62	AVRH2	-	A/D converter upper limit reference voltage
83	AVRH3	-	A/D converter upper limit reference voltage
43	AVSS0	-	*3
	AVRL0		*3
53	AVSS1	-	A/D converter GND
	AVRL1		A/D converter lower limit reference voltage
63	AVSS2	-	A/D converter GND
	AVRL2		A/D converter lower limit reference voltage
82	AVSS3	-	A/D converter GND
	AVRL3		A/D converter lower limit reference voltage
130	C	-	External capacity connection output pin
18, 36, 93, 72, 109, 128, 144	VCC5	-	+5.0V power supply
1, 19, 37, 73, 94, 108, 120, 129	VSS	-	GND

\*1: For the I/O circuit types, see "■ I/O circuit type".

\*2: The MB91F585LB/F586LB/F587LB/F585LD/F586LD/F587LD do not use this pin. Connect it with the VCC5 pin.

\*3: The MB91F585LB/F586LB/F587LB/F585LD/F586LD/F587LD do not use this pin. Connect it with the VSS pin.



## ■ I/O CIRCUIT TYPE

Type	Circuit	Remarks
A		<p>Oscillation feedback resistor: Approx. 1 MΩ</p>
B		<ul style="list-style-type: none"> <li>• CMOS hysteresis input</li> <li>• With 50 kΩ pull-up resistor</li> </ul>
C		<ul style="list-style-type: none"> <li>• Schmitt input</li> <li>• With high withstand voltage control</li> </ul>
D		<ul style="list-style-type: none"> <li>• General-purpose I/O port</li> <li>• CMOS level output <math>I_{OH} = -2/-5\text{mA}</math>, <math>I_{OL} = 2/5\text{mA}</math></li> <li>• With 50kΩ pull-up resistor control</li> <li>• CMOS hysteresis input (0.7V<sub>cc</sub>/0.3V<sub>cc</sub>)</li> <li>• Automotive input (0.8V<sub>cc</sub>/0.5V<sub>cc</sub>)</li> </ul>

# MB91580L Series

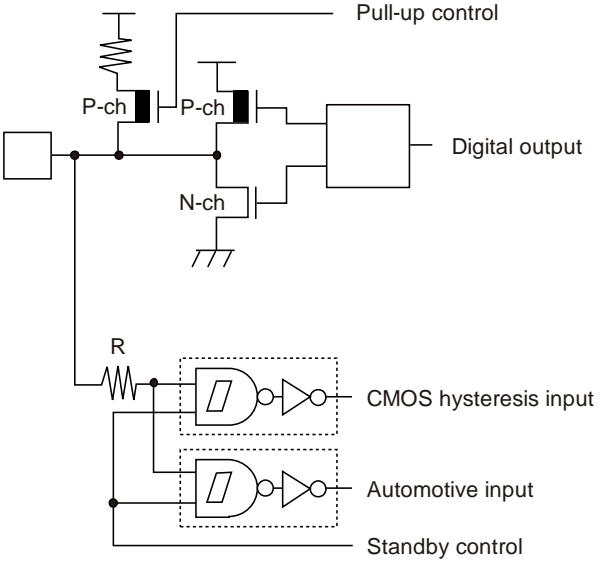
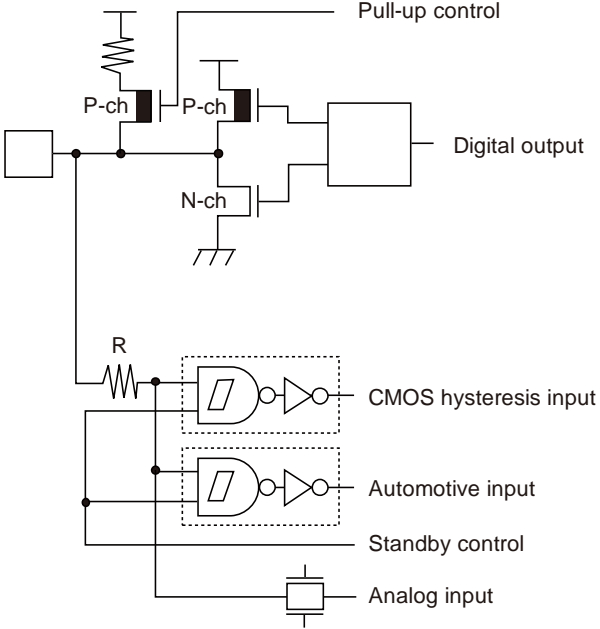
Type	Circuit	Remarks
E	 <p>The diagram for Type E shows a pull-up resistor connected to the input of a P-channel MOSFET. The gate of this P-channel MOSFET is controlled by a 'Pull-up control' signal. The source of the P-channel MOSFET is connected to the input of an N-channel MOSFET. The gates of both MOSFETs are connected to a common input node. The drain of the N-channel MOSFET is connected to ground. The output of the P-channel MOSFET is labeled 'Digital output'. Below the main circuit, there are three input configurations: 'CMOS hysteresis input' (a resistor R connected to a hysteresis input block), 'Automotive input' (a resistor R connected to an automotive input block), and 'Standby control' (a direct connection to a standby control block).</p>	<ul style="list-style-type: none"> <li>• General-purpose I/O port</li> <li>• CMOS level output <math>I_{OH}=-2/-5\text{mA}</math>, <math>I_{OL}=2/5\text{mA}</math></li> <li>• With 50 k<math>\Omega</math> pull-up resistor control</li> <li>• CMOS hysteresis input (0.7V<sub>cc</sub>/0.3V<sub>cc</sub>) During standby, the input value retains the previous value.</li> <li>• Automotive input (0.8V<sub>cc</sub>/0.5V<sub>cc</sub>) During standby, the input value retains the previous value.</li> </ul>
F	 <p>The diagram for Type F is similar to Type E but includes an 'Analog input' block. The pull-up resistor, MOSFETs, and digital output are the same. The input node is connected to the CMOS hysteresis input, Automotive input, and Standby control blocks. Additionally, the input node is connected to an 'Analog input' block, which is represented by a square symbol with a diagonal line.</p>	<ul style="list-style-type: none"> <li>• With analog input, general-purpose I/O port</li> <li>• CMOS level output <math>I_{OH}=-2/-5\text{mA}</math>, <math>I_{OL}=2/5\text{mA}</math></li> <li>• With 50 k<math>\Omega</math> pull-up resistor control</li> <li>• CMOS hysteresis input (0.7V<sub>cc</sub>/0.3V<sub>cc</sub>)</li> <li>• Automotive input (0.8V<sub>cc</sub>/0.5V<sub>cc</sub>)</li> </ul>

Type	Circuit	Remarks
G	<p>The diagram for Type G shows a pull-up resistor connected to the input. The input is connected to the gates of a P-channel MOSFET and an N-channel MOSFET. The P-channel MOSFET's source is connected to V<sub>CC</sub> and its drain is connected to the digital output. The N-channel MOSFET's source is connected to ground and its drain is also connected to the digital output. A pull-up control signal is connected to the gates of both MOSFETs. Below the input, there are three input options: CMOS hysteresis input (with a resistor R), Automotive input, and Standby control. An Analog input is also shown at the bottom.</p>	<ul style="list-style-type: none"> <li>• With analog input, general-purpose I/O port</li> <li>• CMOS level output <math>I_{OH}=-2/-5\text{mA}</math>, <math>I_{OL}=2/5\text{mA}</math></li> <li>• With 50 k<math>\Omega</math> pull-up resistor control</li> <li>• CMOS hysteresis input (0.7V<sub>CC</sub>/0.3V<sub>CC</sub>) During standby, the input value retains the previous value.</li> <li>• Automotive input (0.8V<sub>CC</sub>/0.5V<sub>CC</sub>) During standby, the input value retains the previous value.</li> </ul>
H*	<p>The diagram for Type H* shows a simple connection from an analog input to the input terminal.</p>	Analog input
I*	<p>The diagram for Type I* shows a simple connection from the output terminal to an analog output.</p>	Analog output
J*	<p>The diagram for Type J* shows a P-channel MOSFET and an N-channel MOSFET connected to a digital output. The P-channel MOSFET's source is connected to V<sub>CC</sub> and its drain is connected to the digital output. The N-channel MOSFET's source is connected to ground and its drain is also connected to the digital output.</p>	CMOS level output $I_{OH}=-2/-5\text{mA}$ , $I_{OL}=2/5\text{mA}$
K	<p>The diagram for Type K is identical to Type G, showing a pull-up resistor, P-ch and N-ch transistors, a digital output, CMOS hysteresis input, Automotive input, Standby control, and Analog input.</p>	<ul style="list-style-type: none"> <li>• With I<sup>2</sup>C, general-purpose I/O port</li> <li>• CMOS level output <math>I_{OH}=-3\text{mA}</math>, <math>I_{OL}=3\text{mA}</math> (at I<sup>2</sup>C output) <math>I_{OH}=-2/-5\text{mA}</math>, <math>I_{OL}=2/5\text{mA}</math> (other than above)</li> <li>• With 50 k<math>\Omega</math> pull-up resistor control</li> <li>• CMOS hysteresis input (0.7V<sub>CC</sub>/0.3V<sub>CC</sub>)</li> <li>• Automotive input (0.8V<sub>CC</sub>/0.5V<sub>CC</sub>)</li> </ul>

# MB91580L Series

Type	Circuit	Remarks
L		Open drain I/O
M		<ul style="list-style-type: none"> <li>• With analog input, I<sup>2</sup>C, general-purpose I/O port</li> <li>• CMOS level output I<sub>OH</sub>=-3mA, I<sub>OL</sub>=3mA (at I<sup>2</sup>C output) I<sub>OH</sub>=-2/-5mA, I<sub>OL</sub>=2/5mA (other than above)</li> <li>• With 50 kΩ pull-up resistor control</li> <li>• CMOS hysteresis input (0.7V<sub>cc</sub>/0.3V<sub>cc</sub>)</li> <li>• Automotive input (0.8V<sub>cc</sub>/0.5V<sub>cc</sub>)</li> </ul>
N		<ul style="list-style-type: none"> <li>• With analog output, general-purpose I/O port</li> <li>• CMOS level output I<sub>OH</sub>=-2/-4mA, I<sub>OL</sub>=2/4mA</li> <li>• With 50 kΩ pull-up resistor control</li> <li>• FlexRay input (0.65V<sub>cc</sub>/0.35V<sub>cc</sub>)</li> <li>• Automotive input (0.8V<sub>cc</sub>/0.5V<sub>cc</sub>)</li> </ul>

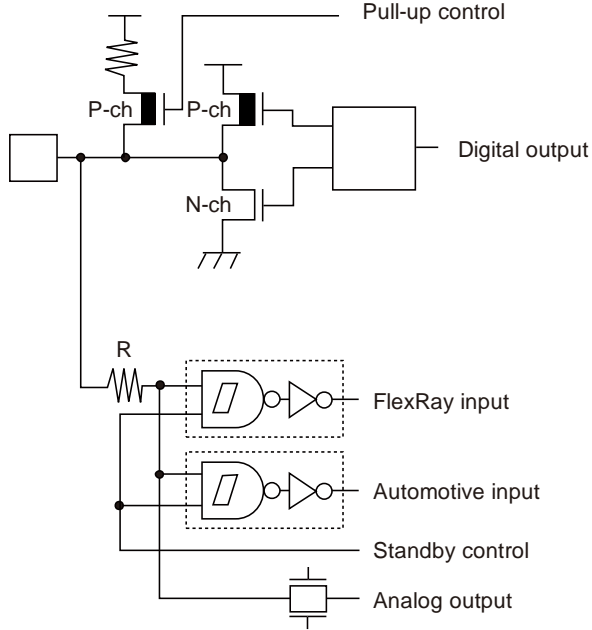
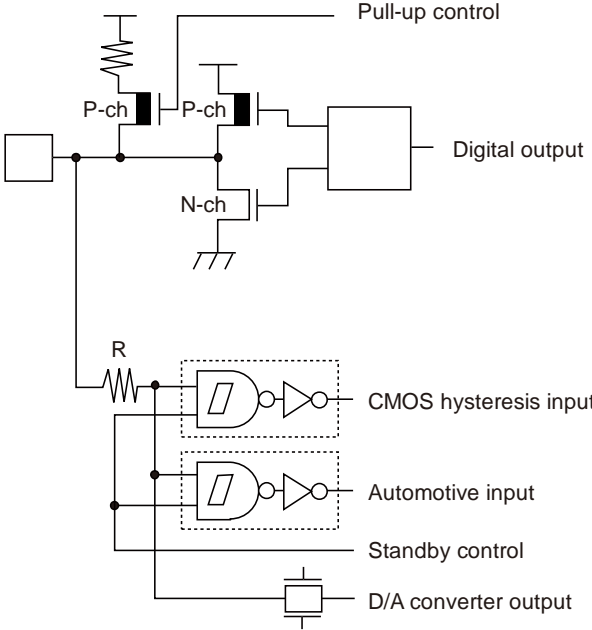
Type	Circuit	Remarks
O		<ul style="list-style-type: none"> <li>• With analog output, general-purpose I/O port</li> <li>• CMOS level output <math>I_{OH}=-2/-4\text{mA}</math>, <math>I_{OL}=2/4\text{mA}</math></li> <li>• With 50 k<math>\Omega</math> pull-up resistor control</li> <li>• FlexRay input (0.65V<sub>cc</sub>/0.35V<sub>cc</sub>) During standby, the input value retains the previous value.</li> <li>• Automotive input (0.8V<sub>cc</sub>/0.5V<sub>cc</sub>) During standby, the input value retains the previous value.</li> </ul>
P		<ul style="list-style-type: none"> <li>• With D/A converter output, general-purpose I/O port</li> <li>• CMOS level output <math>I_{OH}=-2/-5\text{mA}</math>, <math>I_{OL}=2/5\text{mA}</math></li> <li>• With 50 k<math>\Omega</math> pull-up resistor control</li> <li>• CMOS hysteresis input (0.7V<sub>cc</sub>/0.3V<sub>cc</sub>)</li> <li>• Automotive input (0.8V<sub>cc</sub>/0.5V<sub>cc</sub>)</li> </ul>

\*: MB91F585LA/F586LA/F587LA/F585LC/F586LC/F587LC only

## ■ HANDLING PRECAUTIONS

Any semiconductor devices have inherently a certain rate of failure. The possibility of failure is greatly affected by the conditions in which they are used (circuit conditions, environmental conditions, etc.). This page describes precautions that must be observed to minimize the chance of failure and to obtain higher reliability from your FUJITSU SEMICONDUCTOR semiconductor devices.

### 1. Precautions for Product Design

This section describes precautions when designing electronic equipment using semiconductor devices.

- Absolute Maximum Ratings

Semiconductor devices can be permanently damaged by application of stress (voltage, current, temperature, etc.) in excess of certain established limits, called absolute maximum ratings. Do not exceed these ratings.

- Recommended Operating Conditions

Recommended operating conditions are normal operating ranges for the semiconductor device. All the device's electrical characteristics are warranted when operated within these ranges.

Always use semiconductor devices within the recommended operating conditions. Operation outside these ranges may adversely affect reliability and could result in device failure.

No warranty is made with respect to uses, operating conditions, or combinations not represented on the data sheet. Users considering application outside the listed conditions are advised to contact their sales representative beforehand.

- Processing and Protection of Pins

These precautions must be followed when handling the pins which connect semiconductor devices to power supply and input/output functions.

- (1) Preventing Over-Voltage and Over-Current Conditions

Exposure to voltage or current levels in excess of maximum ratings at any pin is likely to cause deterioration within the device, and in extreme cases leads to permanent damage of the device. Try to prevent such overvoltage or over-current conditions at the design stage.

- (2) Protection of Output Pins

Shorting of output pins to supply pins or other output pins, or connection to large capacitance can cause large current flows. Such conditions if present for extended periods of time can damage the device.

Therefore, avoid this type of connection.

- (3) Handling of Unused Input Pins

Unconnected input pins with very high impedance levels can adversely affect stability of operation. Such pins should be connected through an appropriate resistance to a power supply pin or ground pin.

- Latch-up

Semiconductor devices are constructed by the formation of P-type and N-type areas on a substrate. When subjected to abnormally high-voltages, internal parasitic PNP junctions (called thyristor structures) may be formed, causing large current levels in excess of several hundred mA to flow continuously at the power supply pin. This condition is called latch-up.

**CAUTION:** The occurrence of latch-up not only causes loss of reliability in the semiconductor device, but can cause injury or damage from high heat, smoke or flame. To prevent this from happening, do the following:

- (1) Be sure that voltages applied to pins do not exceed the absolute maximum ratings. This should include attention to abnormal noise, surge levels, etc.
- (2) Be sure that abnormal current flows do not occur during the power-on sequence.

- Observance of Safety Regulations and Standards

Most countries in the world have established standards and regulations regarding safety, protection from electromagnetic interference, etc. Customers are requested to observe applicable regulations and standards in the design of products.

- Fail-Safe Design

Any semiconductor devices have inherently a certain rate of failure. You must protect against injury, damage or loss from such failures by incorporating safety design measures into your facility and equipment such as redundancy, fire protection, and prevention of over-current levels and other abnormal operating conditions.

- Precautions Related to Usage of Devices

FUJITSU SEMICONDUCTOR semiconductor devices are intended for use in standard applications (computers, office automation and other office equipment, industrial, communications, and measurement equipment, personal or household devices, etc.).

**CAUTION:** Customers considering the use of our products in special applications where failure or abnormal operation may directly affect human lives or cause physical injury or property damage, or where extremely high levels of reliability are demanded (such as aerospace systems, atomic energy controls, sea floor repeaters, vehicle operating controls, medical devices for life support, etc.) are requested to consult with sales representatives before such use. The company will not be responsible for damages arising from such use without prior approval.

## 2. Precautions for Package Mounting

Package mounting may be either lead insertion type or surface mount type. In either case, for heat resistance during soldering, you should only mount under FUJITSU SEMICONDUCTOR's recommended conditions. For detailed information about mount conditions, contact your sales representative.

- Lead Insertion Type

Mounting of lead insertion type packages onto printed circuit boards may be done by two methods: direct soldering on the board, or mounting by using a socket.

Direct mounting onto boards normally involves processes for inserting leads into through-holes on the board and using the flow soldering (wave soldering) method of applying liquid solder. In this case, the soldering process usually causes leads to be subjected to thermal stress in excess of the absolute ratings for storage temperature. Mounting processes should conform to FUJITSU SEMICONDUCTOR recommended mounting conditions.

If socket mounting is used, differences in surface treatment of the socket contacts and IC lead surfaces can lead to contact deterioration after long periods. For this reason it is recommended that the surface treatment of socket contacts and IC leads be verified before mounting.

- Surface Mount Type

Surface mount packaging has longer and thinner leads than lead-insertion packaging, and therefore leads are more easily deformed or bent. The use of packages with higher pin counts and narrower pin pitch results in increased susceptibility to open connections caused by deformed pins, or shorting due to solder bridges.

You must use appropriate mounting techniques. FUJITSU SEMICONDUCTOR recommends the solder reflow method, and has established a ranking of mounting conditions for each product. Users are advised to mount packages in accordance with FUJITSU SEMICONDUCTOR ranking of recommended conditions.

# MB91580L Series

- Lead-Free Packaging

CAUTION: When ball grid array (BGA) packages with Sn-Ag-Cu balls are mounted using Sn-Pb eutectic soldering, junction strength may be reduced under some conditions of use.

- Storage of Semiconductor Devices

Because plastic chip packages are formed from plastic resins, exposure to natural environmental conditions will cause absorption of moisture. During mounting, the application of heat to a package that has absorbed moisture can cause surfaces to peel, reducing moisture resistance and causing packages to crack. To prevent, do the following:

- (1) Avoid exposure to rapid temperature changes, which cause moisture to condense inside the product. Store products in locations where temperature changes are slight.
- (2) Use dry boxes for product storage. Products should be stored below 70% relative humidity, and at temperatures between 5°C and 30°C.  
When you open Dry Package that recommends humidity 40% to 70% relative humidity.
- (3) When necessary, FUJITSU SEMICONDUCTOR packages semiconductor devices in highly moisture-resistant aluminum laminate bags, with a silica gel desiccant. Devices should be sealed in their aluminum laminate bags for storage.
- (4) Avoid storing packages where they are exposed to corrosive gases or high levels of dust.

- Baking

Packages that have absorbed moisture may be de-moisturized by baking (heat drying). Follow the FUJITSU SEMICONDUCTOR recommended conditions for baking.

Condition: 125°C/24 h

- Static Electricity

Because semiconductor devices are particularly susceptible to damage by static electricity, you must take the following precautions:

- (1) Maintain relative humidity in the working environment between 40% and 70%. Use of an apparatus for ion generation may be needed to remove electricity.
- (2) Electrically ground all conveyors, solder vessels, soldering irons and peripheral equipment.
- (3) Eliminate static body electricity by the use of rings or bracelets connected to ground through high resistance (on the level of 1 MΩ).  
Wearing of conductive clothing and shoes, use of conductive floor mats and other measures to minimize shock loads is recommended.
- (4) Ground all fixtures and instruments, or protect with anti-static measures.
- (5) Avoid the use of styrofoam or other highly static-prone materials for storage of completed board assemblies.



### 3. Precautions for Use Environment

Reliability of semiconductor devices depends on ambient temperature and other conditions as described above.

For reliable performance, do the following:

(1) Humidity

Prolonged use in high humidity can lead to leakage in devices as well as printed circuit boards. If high humidity levels are anticipated, consider anti-humidity processing.

(2) Discharge of Static Electricity

When high-voltage charges exist close to semiconductor devices, discharges can cause abnormal operation. In such cases, use anti-static measures or processing to prevent discharges.

(3) Corrosive Gases, Dust, or Oil

Exposure to corrosive gases or contact with dust or oil may lead to chemical reactions that will adversely affect the device. If you use devices in such conditions, consider ways to prevent such exposure or to protect the devices.

(4) Radiation, Including Cosmic Radiation

Most devices are not designed for environments involving exposure to radiation or cosmic radiation. Users should provide shielding as appropriate.

(5) Smoke, Flame

CAUTION: Plastic molded devices are flammable, and therefore should not be used near combustible substances. If devices begin to smoke or burn, there is danger of the release of toxic gases. Customers considering the use of FUJITSU SEMICONDUCTOR products in other special environmental conditions should consult with sales representatives.

Please check the latest handling precautions at the following URL.  
<http://edevice.fujitsu.com/fj/handling-e.pdf>

# MB91580L Series

## ■ HANDLING DEVICES

The latch-up prevention and pin processing are explained below.

### • For latch-up prevention

If a voltage higher than VCC or a voltage lower than VSS is applied to an I/O pin, or if a voltage exceeding the ratings is applied between VCC and VSS pins, a latch-up may occur in CMOS IC. If the latch-up occurs, the power supply current increases excessively and device elements may be damaged by heat. Take care to prevent any voltage from exceeding the maximum ratings in device application.

Also, the analog power supplies (AVCC0\*, AVCC3, AVRH0\*, AVRH1, AVRH2, AVRH3) and analog input must not exceed the digital power supply (VCC5) when the power supply to the analog system is turned on or off.

In the correct power-on sequence, turn on the digital power supply voltage (VCC5) and analog power supply voltages (AVCC0\*, AVCC3, AVRH0\*, AVRH1, AVRH2, AVRH3) simultaneously. Alternatively, turn on the digital power supply voltage (VCC5) first, and then turn on the analog power supplies (AVCC0\*, AVCC3, AVRH0\*, AVRH1, AVRH2, AVRH3).

\*: MB91F585LA/F586LA/F587LA/F585LC/F586LC/F587LC only

### • Treatment of unused pins

If unused input pins are left open, they may cause a permanent damage to the device due to device malfunction or latch-up. Connect a 2kΩ or higher resistor to each of unused input pins for pull-up or pull-down processing.

Also, if I/O pins are not used, they must be set to the output state for releasing or they must be set to the input state and treated in the same way as for the input pins.

### • Power supply pins

The device is designed to ensure that if the device contains multiple VCC or VSS pins, the pins that should be at the same potential are interconnected to prevent latch-up or other malfunctions. Further, connect these pins to an external power supply or ground to reduce unwanted radiation, prevent strobe signals from malfunctioning due to a raised ground level, and fulfill the total output current standard, etc. As shown below, all VSS power supply pins must be treated in the similar way. If multiple VCC or VSS systems are connected, the device cannot operate correctly even within the guaranteed operating range.

## Power Supply Input Pins

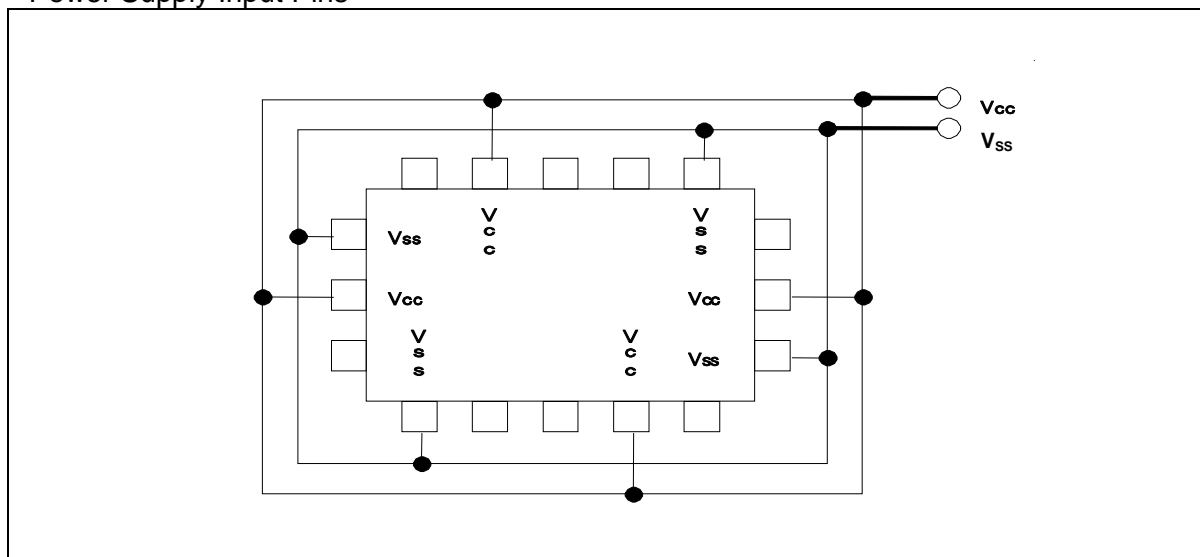

The power supply pins should be connected to VCC and VSS of this device at the low impedance from the power supply source.

In the area close to this device, a ceramic capacitor having the capacitance larger than the capacitor of C pin is recommended to use as a bypass capacitor between VCC and VSS pins.

- **Crystal oscillation circuit**

An external noise to the X0 or X1 pin may cause a device malfunction. The printed circuit board must be designed to lay out X0 and X1 pins, crystal oscillator (or ceramic resonator), and the bypass capacitor to be grounded to the close position to the device.

The printed circuit board artwork is recommended to surround the X0 and X1 pins by ground circuits.

- **Mode pin (MD[1:0])**

Connect the MD[1:0] mode pin to the VCC or VSS pin directly. To prevent an erroneous selection of test mode caused by the noise, reduce the pattern length between each mode pin and VCC or VSS pin on the printed circuit board. Also, use the low-impedance pin connection.

- **During power-on**

To prevent a malfunction of the voltage step-down circuit built in the device, set the voltage rising time to have 50 $\mu$ s or longer (between 0.2V and 2.7V) during power-on.

- **Notes during PLL clock operation**

When the PLL clock is selected and if the oscillator is disconnected or if the input is stopped, this clock may continue to operate at the free running frequency of the self oscillator circuit built in the PLL. This operation is not guaranteed.

- **Treatment of R/D converter\* and A/D converter power supply pins**

Connect the pins to have AVCC0 = AVCC3 = AVRH0 = AVRH1=AVRH2=AVRH3=VCC and AVSS0/AVRL0=AVSS1/AVRL1=AVSS2/AVRL2=AVSS3/AVRL3=VSS even if the R/D converter\* and the A/D converter are not used.

- **Note on using external clock**

The external clock is unsupported.

External direct clock input cannot use.

- **Power-on sequence of R/D converter\* and A/D converter power supply analog inputs**

Be sure to turn on the digital power supply (VCC5) first, and then turn on the R/D converter\* and A/D converter power supplies (AVCC0\*, AVCC3, AVRH0\*, AVRH1, AVRH2, AVRH3, AVRL0\*, AVRL1, AVRL2, AVRL3) and analog inputs (MAG\_PLUS\*, MAG\_MINUS\*, COS\_PLUS\*, COS\_MINUS\*, SIN\_PLUS\*, SIN\_MINUS\*, COS\_IN\*, SIN\_IN\*, AN0 to AN23). Also, turn off the R/D converter\* and A/D converter power supplies (AVCC0\*, AVCC3, AVRH0\*, AVRH1, AVRH2, AVRH3, AVRL0\*, AVRL1, AVRL2, AVRL3) and analog inputs (MAG\_PLUS\*, MAG\_MINUS\*, COS\_PLUS\*, COS\_MINUS\*, SIN\_PLUS\*, SIN\_MINUS\*, COS\_IN\*, SIN\_IN\*, AN0 to AN23) first, and then turn off the digital power supply (VCC5). When the AVRH0\*, AVRH1, AVRH2, and AVRH3 pin voltages are turned on or off, they must not exceed AVCC0\* and AVCC3. Even if a common analog input pin is used as an input port, its input voltage must not exceed AVCC0\* or AVCC3. (However, the analog power supply voltage and digital power supply voltage can be turned on or off simultaneously.)

- **Treatment of C pin**

This device contains a voltage step-down circuit. A capacitor must always be connected to the C pin to assure the internal stabilization of the device. For the standard values, see the "Recommended Operating Conditions" of the latest data sheet.

\*: MB91F585LA/F586LA/F587LA/F585LC/F586LC/F587LC only

## ■ APPLICATION NOTES

### • Function Switching of a Multiplexed Port

To switch between the port function and the multiplexed pin function, use the PFR (port function register). However, if a pin is also used for an external bus, its function is switched by the external bus setting. For details, see "I/O PORTS" in Hardware Manual.

\*: MB91F585LB/F586LB/F587LB/F585LD/F586LD/F587LD only

### • Low-power Consumption Mode

To transit to the sleep mode, watch mode, stop mode, watch mode(power-off) or stop mode(power-off), follow the procedure explained in the "Activating the sleep mode, watch mode, or stop mode" or the "Activating the watch mode (power-off) or stop mode(power-off)" of "POWER CONSUMPTION CONTROL" in Hardware Manual.

Take the following notes when using a monitor debugger.

- Do not set a break point for the low-power consumption transition program.
- Do not execute an operation step for the low-power consumption transition program.

### • Notes When Writing Data in a Register Having the Status Flag

When writing data in the register that has a status flag (especially, an interrupt request flag) to control function, take care not to clear its status flag erroneously.

The program must be written not to clear the flag to the status bit, and to set the control bits to have the desired value.

Especially, if multiple control bits are used, the bit instruction cannot be used. (The bit instruction can access to a single bit only.) The Byte, Half-word, or Word access must be used to write data in the control bits and status flag simultaneously. During this time, take care not to clear other bits (in this case, the bits of status flag) erroneously.

Note: These points can be ignored because the bit instructions already take the points into consideration for registers that support read-modify-write (RMW) operations. These points must be considered when using the bit instructions for registers that do not support RMW operations.

## ■ BLOCK DIAGRAM

- MB91F585LA/F586LA/F587LA/F585LC/F586LC/F587LC

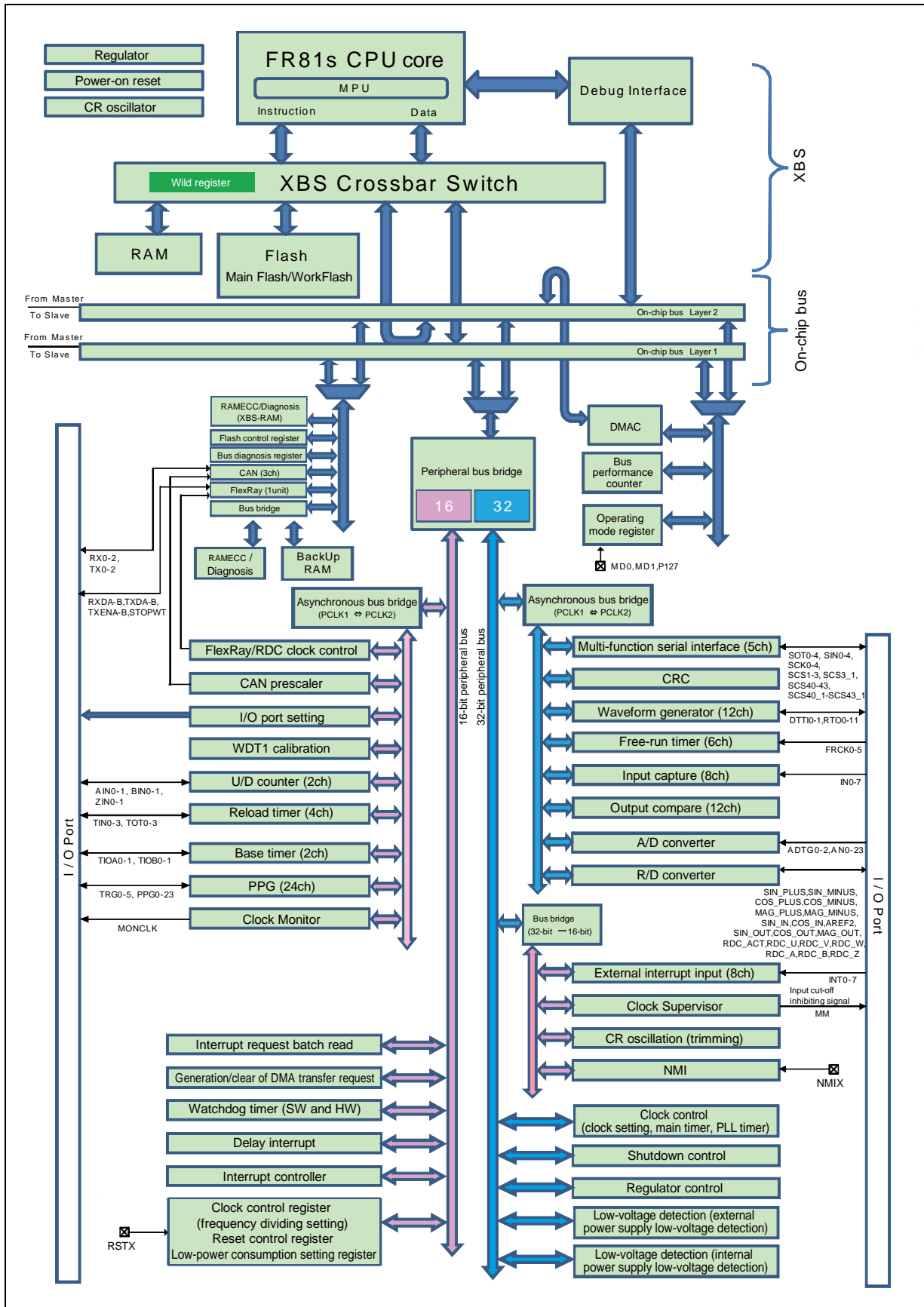

# MB91580L Series

- MB91F585LB/F586LB/F587LB/F585LD/F586LD/F587LD

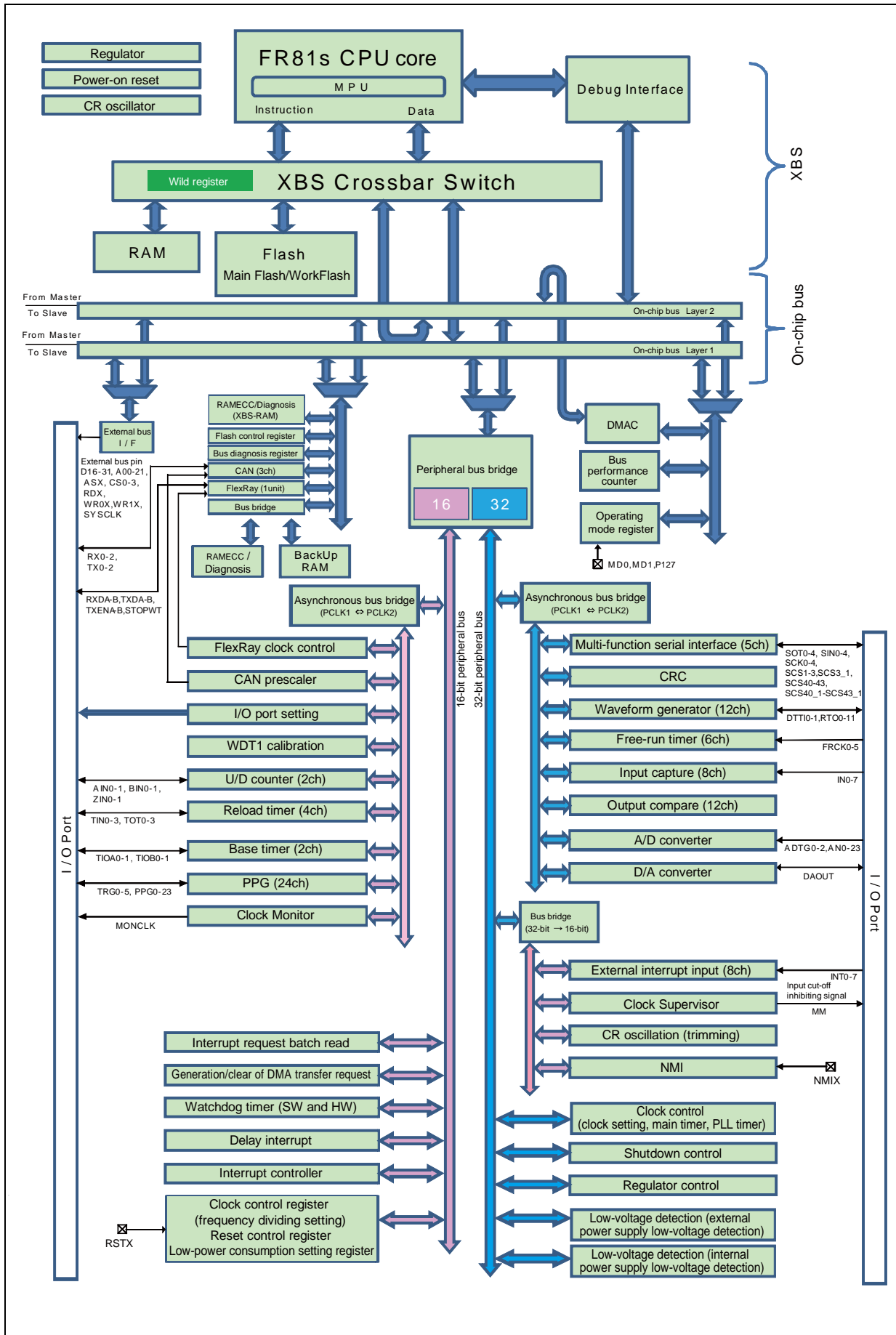

## ■ MEMORY MAP

### • MB91F585LA/F586LA/F587LA/F585LC/F586LC/F587LC

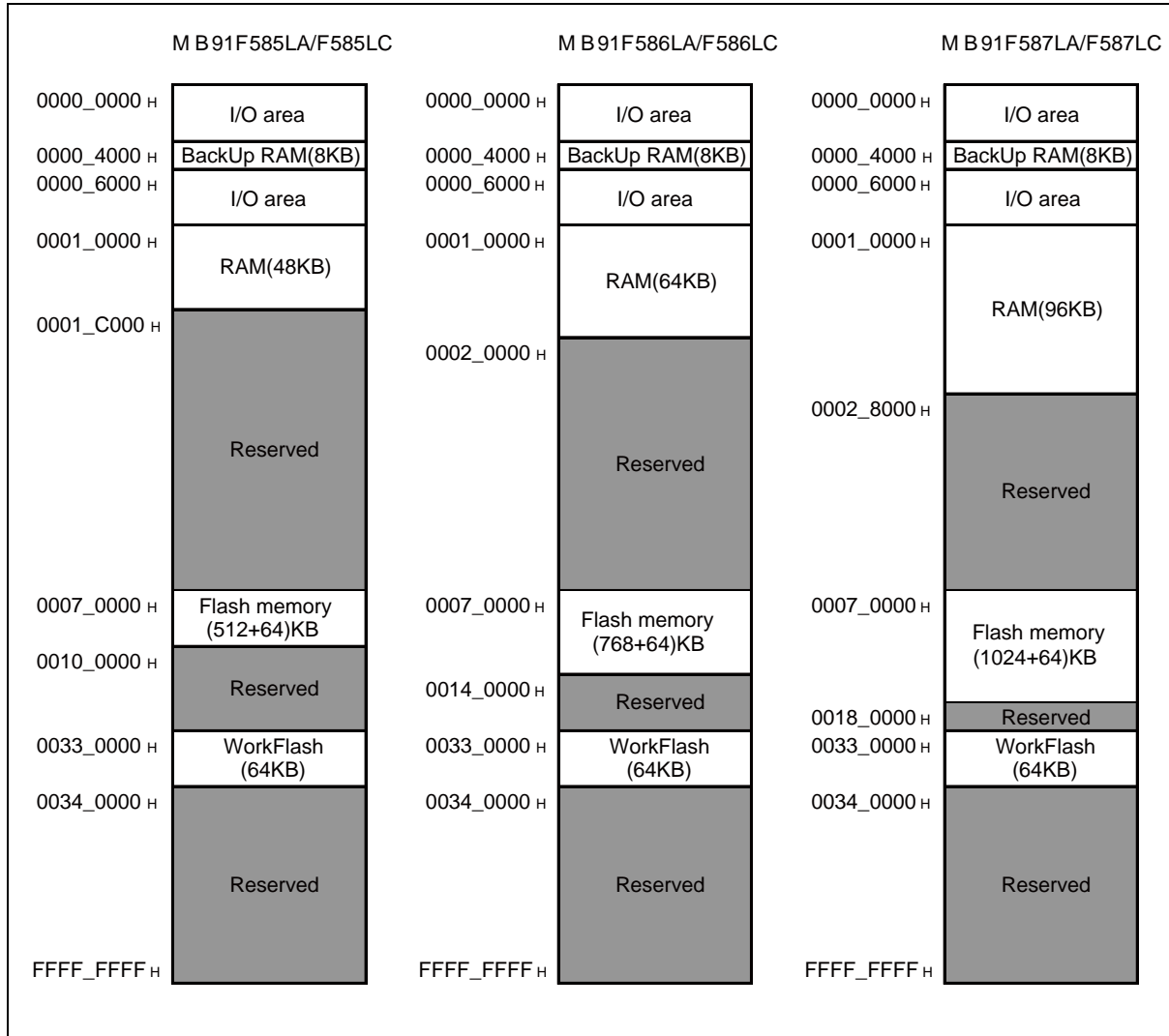

# MB91580L Series

• MB91F585LB/F586LB/F587LB/F585LD/F586LD/F587LD

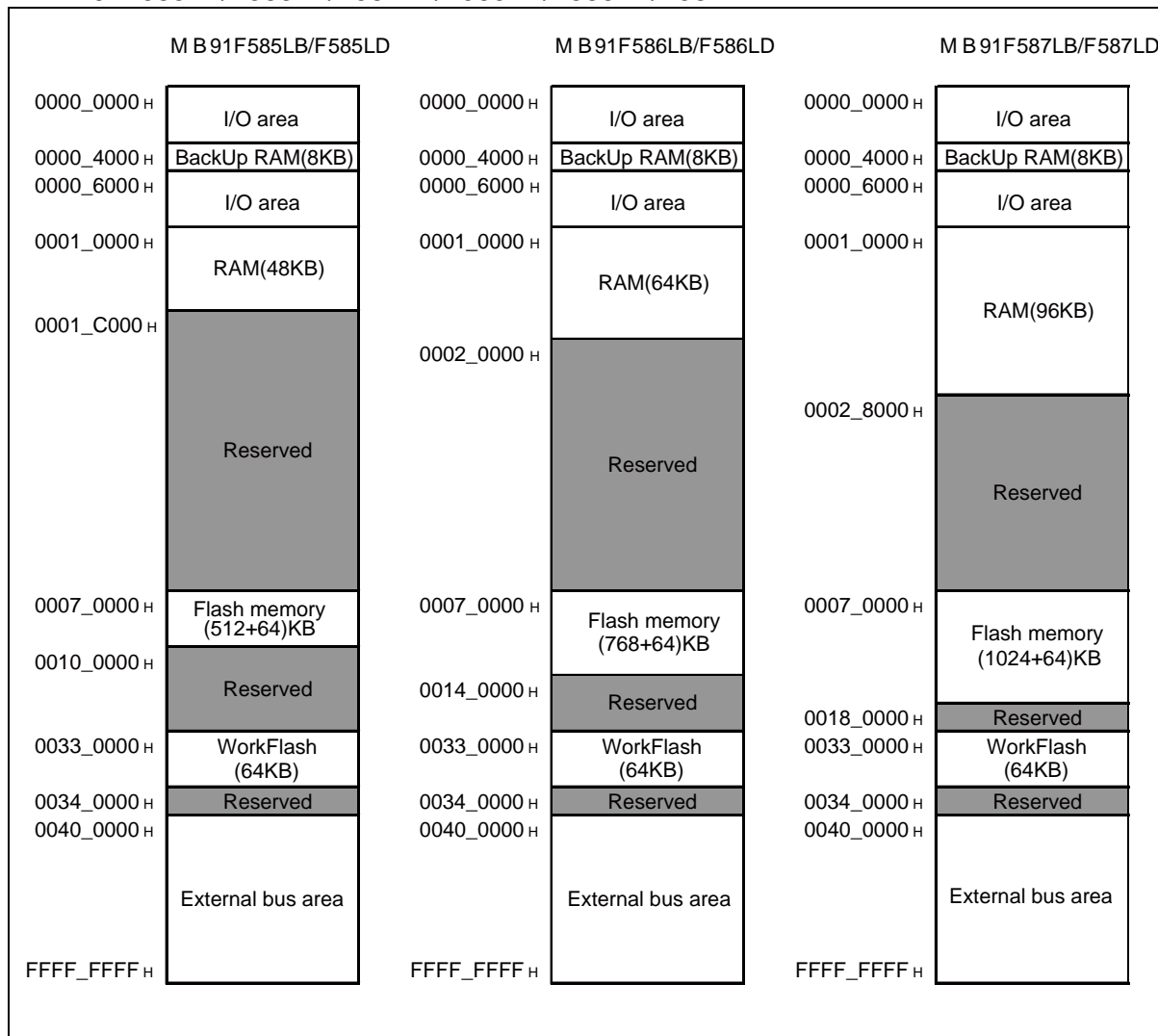



## ■ I/O MAP

The following I/O map shows the relationship between memory space and registers for peripheral resources.

### • Legend of I/O Map

Address	Address offset value/Register name				Block
	+ 0	+ 1	+ 2	+ 3	
000090 <sub>H</sub>	BT1TMR [R] H 00000000 00000000		BT1TMCR [R/W] B,H,W 00000000 00000000		Base timer 1
000094 <sub>H</sub>	-	BT1STC [R/W] B 00000000	-	-	
000098 <sub>H</sub>	BT1PCSR/BT1PRL [R/W] H 00000000 00000000		BT1PDUT/BT1PRLH/BT1DTBF [R/W] H 00000000 00000000		
00009C <sub>H</sub>	BTSEL [R/W] B ----0000	-	BTSSSR [W] B, H -----11		
0000A0 <sub>H</sub>	ADERH [R/W] B, H, W 00000000 00000000		ADERL [R/W] B, H, W 00000000 00000000		A/D converter
0000A4 <sub>H</sub>	ADCS1 [R/W] B,H,W 00000000	ADCS0 [R/W] B,H,W 00000000	ADCR1 [R] B,H,W ----XX	ADCR0 [R] B,H,W XXXXXXX	
0000A8 <sub>H</sub>	ADCT1 [R/W] B,H,W 00010000	ADCT0 [R/W] B,H,W 00101100	ADSCH [R/W] B,H,W ---00000	ADECH [R/W] B,H,W ---00000	

Read/Write attribute (R: Read W: Write)

Data access attribute  
 B: Byte  
 H: Half-word  
 W: Word

**(Note)**  
 The access by the data access attribute not described is disabled.

Initial register value after reset

The initial register values after reset are indicated as follows:

- "1": Initial value "1"
- "0": Initial value "0"
- "X": Initial value undefined
- "-": Reserved bit/Undefined bit
- "\*": Initial value "0" or "1" according to the setting

### Note:

It is prohibited to access addresses not described here.

# MB91580L Series

• MB91F585LA/F586LA/F587LA/F585LC/F586LC/F587LC

Address	Address offset value/Register name				Block
	+0	+1	+2	+3	
000000 <sub>H</sub>	PDR00[R/W] B,H,W XXXXXXXXXX	PDR01[R/W] B,H,W XXXXXXXXXX	PDR02[R/W] B,H,W XXXXXXXXXX	PDR03[R/W] B,H,W XXXXXXXXXX	Port data register
000004 <sub>H</sub>	PDR04[R/W] B,H,W ----XXX	-	PDR06[R/W] B,H,W XXXXXXXXXX	PDR07[R/W] B,H,W XXXXXXXXXX	
000008 <sub>H</sub>	PDR08[R/W] B,H,W XXXXXXXXXX	PDR09[R/W] B,H,W XXXXXXXXXX	PDR10[R/W] B,H,W XXXXXXXXXX	PDR11[R/W] B,H,W XXXXXXXXXX	
00000C <sub>H</sub>	PDR12[R/W] B,H,W XXXXXXXXXX	PDR13[R/W] B,H,W XX-XXXXX	-	-	
000010 <sub>H</sub>   000038 <sub>H</sub>	-	-	-	-	Reserved
00003C <sub>H</sub>	WDTCR0[R/W] B,H,W -0--0000	WDTCPR0[W] B,H,W 00000000	WDTCR1[R] B,H,W ----0010	WDTCPR1[W] B,H,W 00000000	Watchdog timer [S]
000040 <sub>H</sub>	-	-	-	-	Reserved
000044 <sub>H</sub>	DICR[R/W] B -----0	-	-	-	Delay interrupt
000048 <sub>H</sub>   00005C <sub>H</sub>	-	-	-	-	Reserved
000060 <sub>H</sub>	TMRLRA0[R/W] H XXXXXXXXXX XXXXXXXX		TMR0[R] H XXXXXXXXXX XXXXXXXX		Reload timer 0
000064 <sub>H</sub>	TMRLRB0[R/W] H XXXXXXXXXX XXXXXXXX		TMCSR0[R/W] B,H,W 00000000 0-000000		
000068 <sub>H</sub>   00007C <sub>H</sub>	-	-	-	-	Reserved
000080 <sub>H</sub>	BT0TMR[R] H 00000000 00000000		BT0TMCR[R/W] H -0000000 00000000		Base timer 0
000084 <sub>H</sub>	BT0TMCR2[R/W] B -----0	BT0STC[R/W] B -0-0-0-0	-	-	
000088 <sub>H</sub>	BT0PCSR/BT0PRLL[R/W] H 00000000 00000000		BT0PDUT/BT0PRLH/BT0DTBF [R/W] H 00000000 00000000		
00008C <sub>H</sub>	-	-	-	-	
000090 <sub>H</sub>	BT1TMR[R] H 00000000 00000000		BT1TMCR[R/W] H -0000000 00000000		Base timer 1
000094 <sub>H</sub>	BT1TMCR2[R/W] B -----0	BT1STC[R/W] B -0-0-0-0	-	-	
000098 <sub>H</sub>	BT1PCSR/BT1PRLL[R/W] H 00000000 00000000		BT1PDUT/BT1PRLH/BT1DTBF[R/W] H 00000000 00000000		
00009C <sub>H</sub>	BTSEL01[R/W] B ----0000	-	BTSSSR[W] B,H -----11		Base timer 0,1

# MB91580L Series

Address	Address offset value/Register name				Block
	+0	+1	+2	+3	
0000A0 <sub>H</sub>   0000FC <sub>H</sub>	-	-	-	-	Reserved
000100 <sub>H</sub>	TMRLRA1[R/W] H XXXXXXXXXX XXXXXXXXX		TMR1[R] H XXXXXXXXXX XXXXXXXXX		Reload timer 1
000104 <sub>H</sub>	TMRLRB1[R/W] H XXXXXXXXXX XXXXXXXXX		TMCSR1[R/W] B,H,W 00000000 0-000000		
000108 <sub>H</sub>	TMRLRA2[R/W] H XXXXXXXXXX XXXXXXXXX		TMR2[R] H XXXXXXXXXX XXXXXXXXX		Reload timer 2
00010C <sub>H</sub>	TMRLRB2[R/W] H XXXXXXXXXX XXXXXXXXX		TMCSR2[R/W] B,H,W 00000000 0-000000		
000110 <sub>H</sub>	TMRLRA3[R/W] H XXXXXXXXXX XXXXXXXXX		TMR3[R] H XXXXXXXXXX XXXXXXXXX		Reload timer 3
000114 <sub>H</sub>	TMRLRB3[R/W] H XXXXXXXXXX XXXXXXXXX		TMCSR3[R/W] B,H,W 00000000 0-000000		
000118 <sub>H</sub>   00011C <sub>H</sub>	-	-	-	-	Reserved
000120 <sub>H</sub>	IRPR0H[R] B,H,W 00-----	IRPR0L[R] B,H,W 00-----	IRPR1H[R] B,H,W 00-----	IRPR1L[R] B,H,W -----	Interrupt request batch read register
000124 <sub>H</sub>	IRPR2H[R] B,H,W -----	IRPR2L[R] B,H,W 0000---	IRPR3H[R] B,H,W 00-----	IRPR3L[R] B,H,W 00-----	
000128 <sub>H</sub>	IRPR4H[R] B,H,W 00-----	IRPR4L[R] B,H,W 000000--	IRPR5H[R] B,H,W 00-----	IRPR5L[R] B,H,W 00-----	
00012C <sub>H</sub>	IRPR6H[R] B,H,W 000000--	IRPR6L[R] B,H,W 000000--	IRPR7H[R] B,H,W 000000--	IRPR7L[R] B,H,W 000000--	
000130 <sub>H</sub>	IRPR8H[R] B,H,W 000000--	IRPR8L[R] B,H,W 00-----	IRPR9H[R] B,H,W 00-----	IRPR9L[R] B,H,W 00-----	
000134 <sub>H</sub>	IRPR10H[R] B,H,W 00-----	IRPR10L[R] B,H,W 00-----	IRPR11H[R] B,H,W 00-----	IRPR11L[R] B,H,W 0000000-	
000138 <sub>H</sub>	IRPR12H[R] B,H,W 0000000-	IRPR12L[R] B,H,W 00000000	IRPR13H[R] B,H,W 00000000	IRPR13L[R] B,H,W 00000000	
00013C <sub>H</sub>	IRPR14H[R] B,H,W 00-----	IRPR14L[R] B,H,W 00-----	IRPR15H[R] B,H,W 00000000	IRPR15L[R] B,H,W 000000---	
000140 <sub>H</sub>	IRPR16H[R] B,H,W 00-----	IRPR16L[R] B,H,W 00-----	IRPR17H[R] B,H,W 00-----	IRPR17L[R]B,H,W 00-----	
000144 <sub>H</sub>	IRPR18H[R] B,H,W 00-----	IRPR18L[R] B,H,W 000000--	-	-	
000148 <sub>H</sub>   0001FC <sub>H</sub>	-	-	-	-	Reserved
000200 <sub>H</sub>	PCN0[R/W] B,H,W 00000000 000000-0		PCSR0[W] H,W XXXXXXXXXX XXXXXXXXX		PPG0
000204 <sub>H</sub>	PDUT0[W] H,W XXXXXXXXXX XXXXXXXXX		PTMR0[R] H,W 11111111 11111111		
000208 <sub>H</sub>	PCN1[R/W] B,H,W 00000000 000000-0		PCSR1[W] H,W XXXXXXXXXX XXXXXXXXX		PPG1
00020C <sub>H</sub>	PDUT1[W] H,W XXXXXXXXXX XXXXXXXXX		PTMR1[R] H,W 11111111 11111111		

# MB91580L Series

Address	Address offset value/Register name				Block
	+0	+1	+2	+3	
000210 <sub>H</sub>	PCN2[R/W] B,H,W 00000000 000000-0		PCSR2[W] H,W XXXXXXXX XXXXXXXX		PPG2
000214 <sub>H</sub>	PDUT2[W] H,W XXXXXXXX XXXXXXXX		PTMR2[R] H,W 11111111 11111111		
000218 <sub>H</sub>	PCN3[R/W] B,H,W 00000000 000000-0		PCSR3[W] H,W XXXXXXXX XXXXXXXX		PPG3
00021C <sub>H</sub>	PDUT3[W] H,W XXXXXXXX XXXXXXXX		PTMR3[R] H,W 11111111 11111111		
000220 <sub>H</sub>	PCN4[R/W] B,H,W 00000000 000000-0		PCSR4[W] H,W XXXXXXXX XXXXXXXX		PPG4
000224 <sub>H</sub>	PDUT4[W] H,W XXXXXXXX XXXXXXXX		PTMR4[R] H,W 11111111 11111111		
000228 <sub>H</sub>	PCN5[R/W] B,H,W 00000000 000000-0		PCSR5[W] H,W XXXXXXXX XXXXXXXX		PPG5
00022C <sub>H</sub>	PDUT5[W] H,W XXXXXXXX XXXXXXXX		PTMR5[R] H,W 11111111 11111111		
000230 <sub>H</sub>	PCN6[R/W] B,H,W 00000000 000000-0		PCSR6[W] H,W XXXXXXXX XXXXXXXX		PPG6
000234 <sub>H</sub>	PDUT6[W] H,W XXXXXXXX XXXXXXXX		PTMR6[R] H,W 11111111 11111111		
000238 <sub>H</sub>	PCN7[R/W] B,H,W 00000000 000000-0		PCSR7[W] H,W XXXXXXXX XXXXXXXX		PPG7
00023C <sub>H</sub>	PDUT7[W] H,W XXXXXXXX XXXXXXXX		PTMR7[R] H,W 11111111 11111111		
000240 <sub>H</sub>	PCN8[R/W] B,H,W 00000000 000000-0		PCSR8[W] H,W XXXXXXXX XXXXXXXX		PPG8
000244 <sub>H</sub>	PDUT8[W] H,W XXXXXXXX XXXXXXXX		PTMR8[R] H,W 11111111 11111111		
000248 <sub>H</sub>	PCN9[R/W] B,H,W 00000000 000000-0		PCSR9[W] H,W XXXXXXXX XXXXXXXX		PPG9
00024C <sub>H</sub>	PDUT9[W] H,W XXXXXXXX XXXXXXXX		PTMR9[R] H,W 11111111 11111111		
000250 <sub>H</sub>	PCN10[R/W] B,H,W 00000000 000000-0		PCSR10[W] H,W XXXXXXXX XXXXXXXX		PPG10
000254 <sub>H</sub>	PDUT10[W] H,W XXXXXXXX XXXXXXXX		PTMR10[R] H,W 11111111 11111111		
000258 <sub>H</sub>	PCN11[R/W] B,H,W 00000000 000000-0		PCSR11[W] H,W XXXXXXXX XXXXXXXX		PPG11
00025C <sub>H</sub>	PDUT11[W] H,W XXXXXXXX XXXXXXXX		PTMR11[R] H,W 11111111 11111111		
000260 <sub>H</sub>	PCN12[R/W] B,H,W 00000000 000000-0		PCSR12[W] H,W XXXXXXXX XXXXXXXX		PPG12
000264 <sub>H</sub>	PDUT12[W] H,W XXXXXXXX XXXXXXXX		PTMR12[R] H,W 11111111 11111111		
000268 <sub>H</sub>	PCN13[R/W] B,H,W 00000000 000000-0		PCSR13[W] H,W XXXXXXXX XXXXXXXX		PPG13
00026C <sub>H</sub>	PDUT13[W] H,W XXXXXXXX XXXXXXXX		PTMR13[R] H,W 11111111 11111111		
000270 <sub>H</sub>	PCN14[R/W] B,H,W 00000000 000000-0		PCSR14[W] H,W XXXXXXXX XXXXXXXX		PPG14
000274 <sub>H</sub>	PDUT14[W] H,W XXXXXXXX XXXXXXXX		PTMR14[R] H,W 11111111 11111111		

# MB91580L Series

Address	Address offset value/Register name				Block
	+0	+1	+2	+3	
000278 <sub>H</sub>	PCN15[R/W] B,H,W 00000000 000000-0		PCSR15[W] H,W XXXXXXXX XXXXXXXX		PPG15
00027C <sub>H</sub>	PDUT15[W] H,W XXXXXXXX XXXXXXXX		PTMR15[R] H,W 11111111 11111111		
000280 <sub>H</sub>	PCN16[R/W] B,H,W 00000000 000000-0		PCSR16[W] H,W XXXXXXXX XXXXXXXX		PPG16
000284 <sub>H</sub>	PDUT16[W] H,W XXXXXXXX XXXXXXXX		PTMR16[R] H,W 11111111 11111111		
000288 <sub>H</sub>	PCN17[R/W] B,H,W 00000000 000000-0		PCSR17[W] H,W XXXXXXXX XXXXXXXX		PPG17
00028C <sub>H</sub>	PDUT17[W] H,W XXXXXXXX XXXXXXXX		PTMR17[R] H,W 11111111 11111111		
000290 <sub>H</sub>	PCN18[R/W] B,H,W 00000000 000000-0		PCSR18[W] H,W XXXXXXXX XXXXXXXX		PPG18
000294 <sub>H</sub>	PDUT18[W] H,W XXXXXXXX XXXXXXXX		PTMR18[R] H,W 11111111 11111111		
000298 <sub>H</sub>	PCN19[R/W] B,H,W 00000000 000000-0		PCSR19[W] H,W XXXXXXXX XXXXXXXX		PPG19
00029C <sub>H</sub>	PDUT19[W] H,W XXXXXXXX XXXXXXXX		PTMR19[R] H,W 11111111 11111111		
0002A0 <sub>H</sub>	PCN20[R/W] B,H,W 00000000 000000-0		PCSR20[W] H,W XXXXXXXX XXXXXXXX		PPG20
0002A4 <sub>H</sub>	PDUT20[W] H,W XXXXXXXX XXXXXXXX		PTMR20[R] H,W 11111111 11111111		
0002A8 <sub>H</sub>	PCN21[R/W] B,H,W 00000000 000000-0		PCSR21[W] H,W XXXXXXXX XXXXXXXX		PPG21
0002AC <sub>H</sub>	PDUT21[W] H,W XXXXXXXX XXXXXXXX		PTMR21[R] H,W 11111111 11111111		
0002B0 <sub>H</sub>	PCN22[R/W] B,H,W 00000000 000000-0		PCSR22[W] H,W XXXXXXXX XXXXXXXX		PPG22
0002B4 <sub>H</sub>	PDUT22[W] H,W XXXXXXXX XXXXXXXX		PTMR22[R] H,W 11111111 11111111		
0002B8 <sub>H</sub>	PCN23[R/W] B,H,W 00000000 000000-0		PCSR23[W] H,W XXXXXXXX XXXXXXXX		PPG23
0002BC <sub>H</sub>	PDUT23[W] H,W XXXXXXXX XXXXXXXX		PTMR23[R] H,W 11111111 11111111		
0002C0 <sub>H</sub>	GTRS0[R/W] B,H,W -0000000 -0000000		GTRS1[R/W] B,H,W -0000000 -0000000		PPG Control
0002C4 <sub>H</sub>	GTRS2[R/W] B,H,W -0000000 -0000000		GTRS3[R/W] B,H,W -0000000 -0000000		
0002C8 <sub>H</sub>	GTRS4[R/W] B,H,W -0000000 -0000000		GTRS5[R/W] B,H,W -0000000 -0000000		
0002CC <sub>H</sub>	GTRS6[R/W] B,H,W -0000000 -0000000		GTRS7[R/W] B,H,W -0000000 -0000000		
0002D0 <sub>H</sub>	GTRS8[R/W] B,H,W -0000000 -0000000		GTRS9[R/W] B,H,W -0000000 -0000000		
0002D4 <sub>H</sub>	GTRS10[R/W] B,H,W -0000000 -0000000		GTRS11[R/W] B,H,W -0000000 -0000000		
0002D8 <sub>H</sub>	GTREN0[R/W] H,W 00000000 00000000		GTREN1[R/W] H,W ----- 00000000		
0002DC <sub>H</sub>	-		-		Reserved

# MB91580L Series

Address	Address offset value/Register name				Block
	+0	+1	+2	+3	
0002E0 <sub>H</sub>	-	GATEC0[R/W] B,H,W -----00	-	GATEC2[R/W] B,H,W -----00	PPG GATE Control
0002E4 <sub>H</sub>	-	GATEC4[R/W] B,H,W -----00	-	GATEC8[R/W] B,H,W -----00	
0002E8 <sub>H</sub>	-	GATEC10[R/W] B,H,W -----00	-	GATEC12[R/W] B,H,W -----00	
0002EC <sub>H</sub>	-	-	-	-	Reserved
0002F0 <sub>H</sub>	RCRH0[W] H,W 00000000	RCRL0[W] B,H,W 00000000	UDCRH0[R] H,W 00000000	UDCRL0[R] B,H,W 00000000	U/D counter 0
0002F4 <sub>H</sub>	CCR0[R/W] B,H 00000000 -0001000		-	CSR0[R] B 00000000	
0002F8 <sub>H</sub>	RCRH1[W] H,W 00000000	RCRL1[W] B,H,W 00000000	UDCRH1[R] H,W 00000000	UDCRL1[R] B,H,W 00000000	U/D counter 1
0002FC <sub>H</sub>	CCR1[R/W] B,H 00000000 -0001000		-	CSR1[R] B 00000000	
000300 <sub>H</sub>	-				Reserved
000304 <sub>H</sub>	-	-	-	-	Reserved
000308 <sub>H</sub>	-				Reserved
00030C <sub>H</sub>	-	-	-	-	
000310 <sub>H</sub>	-	-	MPUCR[R/W] H 000000-0 ----0100		MPU [S] (Only the CPU can access this area)
000314 <sub>H</sub>	-	-	-	-	
000318 <sub>H</sub>	-				
00031C <sub>H</sub>	-	-	-	-	
000320 <sub>H</sub>	DPVAR[R] W XXXXXXXXXXXXXXXXXXXXXXXXXXXXXXXX				
000324 <sub>H</sub>	-	-	DPVSR[R/W] H ----- 0000--0		
000328 <sub>H</sub>	DEAR[R] W XXXXXXXXXXXXXXXXXXXXXXXXXXXXXXXX				
00032C <sub>H</sub>	-	-	DESR[R/W] H ----- 0000--0		
000330 <sub>H</sub>	PABR0[R/W] W XXXXXXXXXXXXXXXXXXXXXXXXXXXX0000				
000334 <sub>H</sub>	-	-	PACR0[R/W] H 000000-0 0000--0		
000338 <sub>H</sub>	PABR1[R/W] W XXXXXXXXXXXXXXXXXXXXXXXXXXXX0000				
00033C <sub>H</sub>	-	-	PACR1[R/W] H 000000-0 0000--0		
000340 <sub>H</sub>	PABR2[R/W] W XXXXXXXXXXXXXXXXXXXXXXXXXXXX0000				
000344 <sub>H</sub>	-	-	PACR2[R/W] H 000000-0 0000--0		
000348 <sub>H</sub>	PABR3[R/W] W XXXXXXXXXXXXXXXXXXXXXXXXXXXX0000				
00034C <sub>H</sub>	-	-	PACR3[R/W] H 000000-0 0000--0		
000350 <sub>H</sub>	PABR4[R/W] W XXXXXXXXXXXXXXXXXXXXXXXXXXXX0000				

# MB91580L Series

Address	Address offset value/Register name				Block
	+0	+1	+2	+3	
000354 <sub>H</sub>	-	-	PACR4[R/W] H 000000-0 00000--0		MPU [S] (Only the CPU can access this area)
000358 <sub>H</sub>	PABR5[R/W] W XXXXXXXX XXXXXXXX XXXXXXXX XXXX0000				
00035C <sub>H</sub>	-	-	PACR5[R/W] H 000000-0 00000--0		
000360 <sub>H</sub>	PABR6[R/W] W XXXXXXXX XXXXXXXX XXXXXXXX XXXX0000				
000364 <sub>H</sub>	-	-	PACR6[R/W] H 000000-0 00000--0		
000368 <sub>H</sub>	PABR7[R/W] W XXXXXXXX XXXXXXXX XXXXXXXX XXXX0000				
00036C <sub>H</sub>	-	-	PACR7[R/W] H 000000-0 00000--0		
000370 <sub>H</sub>	-	-	-	-	Reserved [S]
000374 <sub>H</sub>	-	-	-	-	
000378 <sub>H</sub>	-	-	-	-	
00037C <sub>H</sub>	-	-	-	-	
000380 <sub>H</sub>	-	-	-	-	
000384 <sub>H</sub>	-	-	-	-	
000388 <sub>H</sub>	-	-	-	-	
00038C <sub>H</sub>	-	-	-	-	Reserved [S]
000390 <sub>H</sub>	-	-	-	-	
000394 <sub>H</sub>	-	-	-	-	
000398 <sub>H</sub>	-	-	-	-	
00039C <sub>H</sub>	-	-	-	-	
0003A0 <sub>H</sub>	-	-	-	-	
0003A4 <sub>H</sub>	-	-	-	-	
0003A8 <sub>H</sub>	-	-	-	-	Reserved [S]
0003AC <sub>H</sub>	-	-	-	-	
0003B0 <sub>H</sub>   0003FC <sub>H</sub>	-	-	-	-	Reserved [S]
000400 <sub>H</sub>	ICSEL0[R/W] B,H,W ----000	ICSEL1[R/W] B,H,W -----0	ICSEL2[R/W] B,H,W -----0	ICSEL3[R/W] B,H,W -----0	Generation and clearing of DMA transfer requests
000404 <sub>H</sub>	ICSEL4[R/W] B,H,W -----0	ICSEL5[R/W] B,H,W -----0	ICSEL6[R/W] B,H,W -----0	ICSEL7[R/W] B,H,W ----000	
000408 <sub>H</sub>	ICSEL8[R/W] B,H,W -----0	ICSEL9[R/W] B,H,W -----0	ICSEL10[R/W] B,H,W ----000	ICSEL11[R/W] B,H,W ----000	
00040C <sub>H</sub>	ICSEL12[R/W] B,H,W ----000	ICSEL13[R/W] B,H,W ----000	ICSEL14[R/W] B,H,W ----000	ICSEL15[R/W] B,H,W -----0	
000410 <sub>H</sub>	ICSEL16[R/W] B,H,W -----0	ICSEL17[R/W] B,H,W -----0	ICSEL18[R/W] B,H,W -----0	ICSEL19[R/W] B,H,W -----0	

# MB91580L Series

Address	Address offset value/Register name				Block	
	+0	+1	+2	+3		
000414 <sub>H</sub>	ICSEL20[R/W] B,H,W -----0	ICSEL21[R/W] B,H,W ----000	ICSEL22[R/W] B,H,W ----000	ICSEL23[R/W] B,H,W ----000	Generation and clearing of DMA transfer requests	
000418 <sub>H</sub>	ICSEL24[R/W] B,H,W ----000	ICSEL25[R/W] B,H,W ----000	ICSEL26[R/W] B,H,W -----0	ICSEL27[R/W] B,H,W -----0		
00041C <sub>H</sub>	-	-	-	-		
000420 <sub>H</sub>	-	-	-	-		
000424 <sub>H</sub>   00043C <sub>H</sub>	-	-	-	-	Reserved	
000440 <sub>H</sub>	ICR00[R/W] B,H,W ---1111	ICR01[R/W] B,H,W ---1111	ICR02[R/W] B,H,W ---1111	ICR03[R/W] B,H,W ---1111	Interrupt controller [S]	
000444 <sub>H</sub>	ICR04[R/W] B,H,W ---1111	ICR05[R/W] B,H,W ---1111	ICR06[R/W] B,H,W ---1111	ICR07[R/W] B,H,W ---1111		
000448 <sub>H</sub>	ICR08[R/W] B,H,W ---1111	ICR09[R/W] B,H,W ---1111	ICR10[R/W] B,H,W ---1111	ICR11[R/W] B,H,W ---1111		
00044C <sub>H</sub>	ICR12[R/W] B,H,W ---1111	ICR13[R/W] B,H,W ---1111	ICR14[R/W] B,H,W ---1111	ICR15[R/W] B,H,W ---1111		
000450 <sub>H</sub>	ICR16[R/W] B,H,W ---1111	ICR17[R/W] B,H,W ---1111	ICR18[R/W] B,H,W ---1111	ICR19[R/W] B,H,W ---1111		
000454 <sub>H</sub>	ICR20[R/W] B,H,W ---1111	ICR21[R/W] B,H,W ---1111	ICR22[R/W] B,H,W ---1111	ICR23[R/W] B,H,W ---1111		
000458 <sub>H</sub>	ICR24[R/W] B,H,W ---1111	ICR25[R/W] B,H,W ---1111	ICR26[R/W] B,H,W ---1111	ICR27[R/W] B,H,W ---1111		
00045C <sub>H</sub>	ICR28[R/W] B,H,W ---1111	ICR29[R/W] B,H,W ---1111	ICR30[R/W] B,H,W ---1111	ICR31[R/W] B,H,W ---1111		
000460 <sub>H</sub>	ICR32[R/W] B,H,W ---1111	ICR33[R/W] B,H,W ---1111	ICR34[R/W] B,H,W ---1111	ICR35[R/W] B,H,W ---1111		
000464 <sub>H</sub>	ICR36[R/W] B,H,W ---1111	ICR37[R/W] B,H,W ---1111	ICR38[R/W] B,H,W ---1111	ICR39[R/W] B,H,W ---1111		
000468 <sub>H</sub>	ICR40[R/W] B,H,W ---1111	ICR41[R/W] B,H,W ---1111	ICR42[R/W] B,H,W ---1111	ICR43[R/W] B,H,W ---1111		
00046C <sub>H</sub>	ICR44[R/W] B,H,W ---1111	ICR45[R/W] B,H,W ---1111	ICR46[R/W] B,H,W ---1111	ICR47[R/W] B,H,W ---1111		
000470 <sub>H</sub>   00047C <sub>H</sub>	-	-	-	-		Reserved [S]



# MB91580L Series

Address	Address offset value/Register name				Block
	+0	+1	+2	+3	
000480 <sub>H</sub>	RSTRR[R] B,H,W XXXX--XX	RSTCR[R/W] B,H,W 111----0	STBCR[R/W] B,H,W* 000---11	-	Reset control [S] Power consumption control [S] * Writing to STBCR by DMA is disabled.
000484 <sub>H</sub>	-	-	-	-	Reserved [S]
000488 <sub>H</sub>	DIVR0[R/W] B,H,W 000----	-	DIVR2[R/W] B,H,W 0011----	-	Clock control [S]
00048C <sub>H</sub>	-	-	-	-	Reserved [S]
000490 <sub>H</sub>	IORR0[R/W] B,H,W -0000000	IORR1[R/W] B,H,W -0000000	IORR2[R/W] B,H,W -0000000	IORR3[R/W] B,H,W -0000000	DMA transfer request from a peripheral [S]
000494 <sub>H</sub>	IORR4[R/W] B,H,W -0000000	IORR5[R/W] B,H,W -0000000	IORR6[R/W] B,H,W -0000000	IORR7[R/W] B,H,W -0000000	
000498 <sub>H</sub>	-	-	-	-	
00049C <sub>H</sub>	-	-	-	-	
0004A0 <sub>H</sub>	-	-	-	-	Reserved
0004A4 <sub>H</sub>	CANPRE[R/W] B,H,W ----0000	-	-	-	CAN prescaler
0004A8 <sub>H</sub>   0004AC <sub>H</sub>	-	-	-	-	Reserved
0004B0 <sub>H</sub>	-	-	-	-	Reserved
0004B4 <sub>H</sub>   0004C0 <sub>H</sub>	-	-	-	-	Reserved
0004C4 <sub>H</sub>	CUCR1[R/W] B,H,W -----0--00		CUTD1[R/W] B,H,W 11000011 01010000		WDT1 calibration
0004C8 <sub>H</sub>	CUTR1[R] B,H,W ----- 00000000 00000000 00000000				
0004CC <sub>H</sub>   0004DC <sub>H</sub>	-	-	-	-	Reserved
0004E0 <sub>H</sub>	-	-	CSCFG[R/W] B,H,W ---0----	CMCFG[R/W] B,H,W 00000000	Clock monitor
0004E4 <sub>H</sub>	-	-	-	-	
0004E8 <sub>H</sub>	PLL2DIVM[R/W] B,H,W ----0000	PLL2DIVN[R/W] B,H,W -0000000	PLL2DIVG[R/W] B,H,W ----0000	PLL2MULG[R/W] B,H,W 00000000	FlexRay/RDC clock control
0004EC <sub>H</sub>	PLL2CTRL[R/W] B,H,W ----0000	PLL2DIVK[R/W] B,H,W -----0	CLKR2[R/W] B,H,W 000--000	-	
0004F0 <sub>H</sub>   0004FC <sub>H</sub>	-	-	-	-	Reserved
000500 <sub>H</sub>					Reserved
000504 <sub>H</sub>					Reserved

# MB91580L Series

Address	Address offset value/Register name				Block
	+0	+1	+2	+3	
000508 <sub>H</sub>   00050C <sub>H</sub>	-	-	-	-	Reserved
000510 <sub>H</sub>	CSELR[R/W] B,H,W -0----00	CMONR[R] B,H,W -01---00	MTMCR[R/W] B,H,W 00001111	-	Clock control [S]
000514 <sub>H</sub>	PLLCR[R/W] B,H,W 00-00000 11110000		CSTBR[R/W] B,H,W ----0000	PTMCR[R/W] B,H,W 00-----	
000518 <sub>H</sub>	-	-	CPUAR[R/W] B,H,W 0---XXXX	-	Reset [S]
00051C <sub>H</sub>	-	-	-	-	Reserved [S]
000520 <sub>H</sub>	CCPSEL[R/W] B,H,W -----0	-	-	CCPSDIVR[R/W] B,H,W -000-000	Clock control 2
000524 <sub>H</sub>	-	CCPLLFB[R/W] B,H,W -0000000	CCSSFBR0[R/W] B,H,W --000000	CCSSFBR1[R/W] B,H,W ---00000	
000528 <sub>H</sub>	-	CCSSCCR0[R/W] B,H,W ----0000	CCSSCCR1[R/W] H,W 000-----		
00052C <sub>H</sub>	-	CCCGRCR0[R/W] B,H,W 00----00	CCCGRCR1[R/W] B,H,W 00000000	CCCGRCR2[R/W] B,H,W 00000000	
000530 <sub>H</sub>	-	-	CCPMUCR0[R/W] B,H,W 0----00	CCPMUCR1[R/W] B,H,W 0--00000	
000534 <sub>H</sub>	-	-	-	-	
000538 <sub>H</sub>	-	-	-	-	
00053C <sub>H</sub>	-	-	-	-	
000540 <sub>H</sub>   00054C <sub>H</sub>	-	-	-	-	Reserved
000550 <sub>H</sub>	EIRR0[R/W] B,H,W XXXXXXXXXX	ENIR0[R/W] B,H,W 00000000	ELVR0[R/W] B,H,W 00000000 00000000		External interrupt (INT0 to 7)
000554 <sub>H</sub>   000568 <sub>H</sub>	-	-	-	-	Reserved
00056C <sub>H</sub>	-	CSVCR[R/W] B -0--1--0	-	-	CSV
000570 <sub>H</sub>	CRTR[R/W] B,H,W 01111111	-	-	-	WDT1 calibration (trimming)
000574 <sub>H</sub>   00057C <sub>H</sub>	-	-	-	-	Reserved
000580 <sub>H</sub>	REGSEL[R/W] B,H,W 01--110-	-	-	-	Regulator control
000584 <sub>H</sub>	LVD5R[R/W] B,H,W -----1	LVD5F[R/W] B,H,W 0-010--1	LVD[R/W] B,H,W 01000--0	-	Low-voltage detection

# MB91580L Series

Address	Address offset value/Register name				Block
	+0	+1	+2	+3	
000588 <sub>H</sub>   00058C <sub>H</sub>	-	-	-	-	Reserved
000590 <sub>H</sub>	PMUSTR [R/W] B,H,W 0-----1X	PMUCTLR[R/W] B,H,W 0-00----	PWRTMCTL[R/W] B,H,W -----011	-	PMU
000594 <sub>H</sub>	-	PMUINTF1[R/W] B,H,W 00000000	PMUINTF2[R/W] B,H,W -00-----	-	
000598 <sub>H</sub>	-	-	-	-	
00059C <sub>H</sub>	-	-	-	-	
0005A0 <sub>H</sub>   0005FC <sub>H</sub>	-	-	-	-	Reserved
000600 <sub>H</sub>   00060C <sub>H</sub>	-	-	-	-	Reserved [S]
000610 <sub>H</sub>   00063C <sub>H</sub>	-	-	-	-	Reserved [S]
000640 <sub>H</sub>   00064C <sub>H</sub>	-	-	-	-	Reserved [S]
000650 <sub>H</sub>   00067C <sub>H</sub>	-	-	-	-	Reserved [S]
000680 <sub>H</sub>   00068C <sub>H</sub>	-	-	-	-	Reserved [S]
000690 <sub>H</sub>   0006BC <sub>H</sub>	-	-	-	-	Reserved [S]
0006C0 <sub>H</sub>   0006CC <sub>H</sub>	-	-	-	-	Reserved [S]
0006D0 <sub>H</sub>   0006F0 <sub>H</sub>	-	-	-	-	Reserved
0006F4 <sub>H</sub>	-				Reserved
0006F8 <sub>H</sub>   0006FC <sub>H</sub>	-	-	-	-	Reserved
000700 <sub>H</sub>	-				Reserved
000704 <sub>H</sub>   00070C <sub>H</sub>	-	-	-	-	Reserved
000710 <sub>H</sub>	BPC CRA[R/W] B 00000000	BPC CRB[R/W] B 00000000	BPC CRC[R/W] B 00000000	-	Bus performance counter
000714 <sub>H</sub>	BPCTRA[R/W] W 00000000 00000000 00000000 00000000				
000718 <sub>H</sub>	BPCTRB[R/W] W 00000000 00000000 00000000 00000000				
00071C <sub>H</sub>	BPCTRC[R/W] W 00000000 00000000 00000000 00000000				

# MB91580L Series

Address	Address offset value/Register name				Block
	+0	+1	+2	+3	
000720 <sub>H</sub>   0007F8 <sub>H</sub>	-	-	-	-	Reserved
0007FC <sub>H</sub>	BMODR[R] B,H,W XXXXXXXX	-	-	-	Operation mode
000800 <sub>H</sub>   00083C <sub>H</sub>	-	-	-	-	Reserved [S]
000840 <sub>H</sub>	FCTLR[R/W] H -0--1000 0--0----		-	FSTR[R/W] B -----001	Flash memory register [S]
000844 <sub>H</sub>	-	-	-	-	Reserved [S]
000848 <sub>H</sub>   000854 <sub>H</sub>	-	-	-	-	Reserved [S]
000858 <sub>H</sub>	-	-	WREN[R/W] H 00000000 00000000		Wild register [S]
00085C <sub>H</sub>   00087C <sub>H</sub>	-	-	-	-	Reserved [S]
000880 <sub>H</sub>	WRAR00[R/W] W ----- --XXXXXX XXXXXXXXX XXXXXXX--				Wild register [S]
000884 <sub>H</sub>	WRDR00[R/W] W XXXXXXXX XXXXXXXXX XXXXXXXXX XXXXXXXXX				
000888 <sub>H</sub>	WRAR01[R/W] W ----- --XXXXXX XXXXXXXXX XXXXXXX--				
00088C <sub>H</sub>	WRDR01[R/W] W XXXXXXXX XXXXXXXXX XXXXXXXXX XXXXXXXXX				
000890 <sub>H</sub>	WRAR02[R/W] W ----- --XXXXXX XXXXXXXXX XXXXXXX--				
000894 <sub>H</sub>	WRDR02[R/W] W XXXXXXXX XXXXXXXXX XXXXXXXXX XXXXXXXXX				
000898 <sub>H</sub>	WRAR03[R/W] W ----- --XXXXXX XXXXXXXXX XXXXXXX--				
00089C <sub>H</sub>	WRDR03[R/W] W XXXXXXXX XXXXXXXXX XXXXXXXXX XXXXXXXXX				
0008A0 <sub>H</sub>	WRAR04[R/W] W ----- --XXXXXX XXXXXXXXX XXXXXXX--				
0008A4 <sub>H</sub>	WRDR04[R/W] W XXXXXXXX XXXXXXXXX XXXXXXXXX XXXXXXXXX				
0008A8 <sub>H</sub>	WRAR05[R/W] W ----- --XXXXXX XXXXXXXXX XXXXXXX--				
0008AC <sub>H</sub>	WRDR05[R/W] W XXXXXXXX XXXXXXXXX XXXXXXXXX XXXXXXXXX				
0008B0 <sub>H</sub>	WRAR06[R/W] W ----- --XXXXXX XXXXXXXXX XXXXXXX--				
0008B4 <sub>H</sub>	WRDR06[R/W] W XXXXXXXX XXXXXXXXX XXXXXXXXX XXXXXXXXX				
0008B8 <sub>H</sub>	WRAR07[R/W] W ----- --XXXXXX XXXXXXXXX XXXXXXX--				
0008BC <sub>H</sub>	WRDR07[R/W] W XXXXXXXX XXXXXXXXX XXXXXXXXX XXXXXXXXX				
0008C0 <sub>H</sub>	WRAR08[R/W] W ----- --XXXXXX XXXXXXXXX XXXXXXX--				
0008C4 <sub>H</sub>	WRDR08[R/W] W XXXXXXXX XXXXXXXXX XXXXXXXXX XXXXXXXXX				

# MB91580L Series

Address	Address offset value/Register name				Block
	+0	+1	+2	+3	
0008C8 <sub>H</sub>	WRAR09[R/W] W ----- --XXXXXX XXXXXXXX XXXXXXX--				Wild register [S]
0008CC <sub>H</sub>	WRDR09[R/W] W XXXXXXXX XXXXXXXX XXXXXXXX XXXXXXXX				
0008D0 <sub>H</sub>	WRAR10[R/W] W ----- --XXXXXX XXXXXXXX XXXXXXX--				
0008D4 <sub>H</sub>	WRDR10[R/W] W XXXXXXXX XXXXXXXX XXXXXXXX XXXXXXXX				
0008D8 <sub>H</sub>	WRAR11[R/W] W ----- --XXXXXX XXXXXXXX XXXXXXX--				
0008DC <sub>H</sub>	WRDR11[R/W] W XXXXXXXX XXXXXXXX XXXXXXXX XXXXXXXX				
0008E0 <sub>H</sub>	WRAR12[R/W] W ----- --XXXXXX XXXXXXXX XXXXXXX--				
0008E4 <sub>H</sub>	WRDR12[R/W] W XXXXXXXX XXXXXXXX XXXXXXXX XXXXXXXX				
0008E8 <sub>H</sub>	WRAR13[R/W] W ----- --XXXXXX XXXXXXXX XXXXXXX--				
0008EC <sub>H</sub>	WRDR13[R/W] W XXXXXXXX XXXXXXXX XXXXXXXX XXXXXXXX				
0008F0 <sub>H</sub>	WRAR14[R/W] W ----- --XXXXXX XXXXXXXX XXXXXXX--				
0008F4 <sub>H</sub>	WRDR14[R/W] W XXXXXXXX XXXXXXXX XXXXXXXX XXXXXXXX				
0008F8 <sub>H</sub>	WRAR15[R/W] W ----- --XXXXXX XXXXXXXX XXXXXXX--				
0008FC <sub>H</sub>	WRDR15[R/W] W XXXXXXXX XXXXXXXX XXXXXXXX XXXXXXXX				
000900 <sub>H</sub>   000BF8 <sub>H</sub>	-	-	-	-	
000BFC <sub>H</sub>	-	-	UER[W] B,H,W ----- -----X		OCDU
000C00 <sub>H</sub>	DCCR0[R/W] W 0----000 --00--00 00000000 0-000000				DMA controller [S]
000C04 <sub>H</sub>	DCSR0[R/W] H 0----- -----000		DTCR0[R/W] H 00000000 00000000		
000C08 <sub>H</sub>	DSAR0[R/W] W XXXXXXXX XXXXXXXX XXXXXXXX XXXXXXXX				
000C0C <sub>H</sub>	DDAR0[R/W] W XXXXXXXX XXXXXXXX XXXXXXXX XXXXXXXX				
000C10 <sub>H</sub>	DCCR1[R/W] W 0----000 --00--00 00000000 0-000000				
000C14 <sub>H</sub>	DCSR1[R/W] H 0----- -----000		DTCR1[R/W] H 00000000 00000000		
000C18 <sub>H</sub>	DSAR1[R/W] W XXXXXXXX XXXXXXXX XXXXXXXX XXXXXXXX				
000C1C <sub>H</sub>	DDAR1[R/W] W XXXXXXXX XXXXXXXX XXXXXXXX XXXXXXXX				
000C20 <sub>H</sub>	DCCR2[R/W] W 0----000 --00--00 00000000 0-000000				
000C24 <sub>H</sub>	DCSR2[R/W] H 0----- -----000		DTCR2[R/W] H 00000000 00000000		
000C28 <sub>H</sub>	DSAR2[R/W] W XXXXXXXX XXXXXXXX XXXXXXXX XXXXXXXX				

# MB91580L Series

Address	Address offset value/Register name				Block
	+0	+1	+2	+3	
000C2C <sub>H</sub>	DDAR2[R/W] W XXXXXXXXXXXXXXXXXXXXXXXXXXXXXXXX				DMA controller [S]
000C30 <sub>H</sub>	DCCR3[R/W] W 0----000 --00--00 00000000 0-000000				
000C34 <sub>H</sub>	DCSR3[R/W] H 0----- ----000		DTCR3[R/W] H 00000000 00000000		
000C38 <sub>H</sub>	DSAR3[R/W] W XXXXXXXXXXXXXXXXXXXXXXXXXXXXXXXX				
000C3C <sub>H</sub>	DDAR3[R/W] W XXXXXXXXXXXXXXXXXXXXXXXXXXXXXXXX				
000C40 <sub>H</sub>	DCCR4[R/W] W 0----000 --00--00 00000000 0-000000				
000C44 <sub>H</sub>	DCSR4[R/W] H 0----- ----000		DTCR4[R/W] H 00000000 00000000		
000C48 <sub>H</sub>	DSAR4[R/W] W XXXXXXXXXXXXXXXXXXXXXXXXXXXXXXXX				
000C4C <sub>H</sub>	DDAR4[R/W] W XXXXXXXXXXXXXXXXXXXXXXXXXXXXXXXX				
000C50 <sub>H</sub>	DCCR5[R/W] W 0----000 --00--00 00000000 0-000000				
000C54 <sub>H</sub>	DCSR5[R/W] H 0----- ----000		DTCR5[R/W] H 00000000 00000000		
000C58 <sub>H</sub>	DSAR5[R/W] W XXXXXXXXXXXXXXXXXXXXXXXXXXXXXXXX				
000C5C <sub>H</sub>	DDAR5[R/W] W XXXXXXXXXXXXXXXXXXXXXXXXXXXXXXXX				
000C60 <sub>H</sub>	DCCR6[R/W] W 0----000 --00--00 00000000 0-000000				
000C64 <sub>H</sub>	DCSR6[R/W] H 0----- ----000		DTCR6[R/W] H 00000000 00000000		
000C68 <sub>H</sub>	DSAR6[R/W] W XXXXXXXXXXXXXXXXXXXXXXXXXXXXXXXX				
000C6C <sub>H</sub>	DDAR6[R/W] W XXXXXXXXXXXXXXXXXXXXXXXXXXXXXXXX				
000C70 <sub>H</sub>	DCCR7[R/W] W 0----000 --00--00 00000000 0-000000				
000C74 <sub>H</sub>	DCSR7[R/W] H 0----- ----000		DTCR7[R/W] H 00000000 00000000		
000C78 <sub>H</sub>	DSAR7[R/W] W XXXXXXXXXXXXXXXXXXXXXXXXXXXXXXXX				
000C7C <sub>H</sub>	DDAR7[R/W] W XXXXXXXXXXXXXXXXXXXXXXXXXXXXXXXX				
000C80 <sub>H</sub>   000DF0 <sub>H</sub>	-	-	-	-	
000DF4 <sub>H</sub>	-	-	DNMIR[R/W] B 0-----0	DILVR[R/W] B ---1111	
000DF8 <sub>H</sub>	DMACR[R/W] W 0-----0-----0-----				
000DFC <sub>H</sub>	-	-	-	-	

# MB91580L Series

Address	Address offset value/Register name				Block
	+0	+1	+2	+3	
000E00 <sub>H</sub>	DDR00[R/W] B,H 00000000	DDR01[R/W] B,H 00000000	DDR02[R/W] B,H 00000000	DDR03[R/W] B,H 00000000	Data direction register
000E04 <sub>H</sub>	DDR04[R/W] B,H ----000	-	DDR06[R/W] B,H 00000000	DDR07[R/W] B,H 00000000	
000E08 <sub>H</sub>	DDR08[R/W] B,H 00000000	DDR09[R/W] B,H 00000000	DDR10[R/W] B,H 00000000	DDR11[R/W] B,H 00000000	
000E0C <sub>H</sub>	DDR12[R/W] B,H 00000000	DDR13[R/W] B,H 00-00000	-	-	
000E10 <sub>H</sub>   000E1C <sub>H</sub>	-	-	-	-	Reserved
000E20 <sub>H</sub>	PFR00[R/W] B,H 00000000	PFR01[R/W] B,H 00000000	PFR02[R/W] B,H 00000000	PFR03[R/W] B,H 00000000	Port function register
000E24 <sub>H</sub>	PFR04[R/W] B,H ----000	-	PFR06[R/W] B,H 00000000	PFR07[R/W] B,H 00000000	
000E28 <sub>H</sub>	PFR08[R/W] B,H 00000000	PFR09[R/W] B,H 00000000	PFR10[R/W] B,H 00000000	PFR11[R/W] B,H 00000000	
000E2C <sub>H</sub>	PFR12[R/W] B,H 00000000	PFR13[R/W] B,H 00-00000	-	-	
000E30 <sub>H</sub>   000E3C <sub>H</sub>	-	-	-	-	Reserved
000E40 <sub>H</sub>	PDDR00[R] B,H,W XXXXXXXXXX	PDDR01[R] B,H,W XXXXXXXXXX	PDDR02[R] B,H,W XXXXXXXXXX	PDDR03[R] B,H,W XXXXXXXXXX	Input data direct read register
000E44 <sub>H</sub>	PDDR04[R] B,H,W ----XXX	-	PDDR06[R] B,H,W XXXXXXXXXX	PDDR07[R] B,H,W XXXXXXXXXX	
000E48 <sub>H</sub>	PDDR08[R] B,H,W XXXXXXXXXX	PDDR09[R] B,H,W XXXXXXXXXX	PDDR10[R] B,H,W XXXXXXXXXX	PDDR11[R] B,H,W XXXXXXXXXX	
000E4C <sub>H</sub>	PDDR12[R] B,H,W XXXXXXXXXX	PDDR13[R] B,H,W XX-XXXXX	-	-	
000E50 <sub>H</sub>   000E5C <sub>H</sub>	-	-	-	-	Reserved
000E60 <sub>H</sub>	EPFR00[R/W] B,H ----000	EPFR01[R/W] B,H -----00	EPFR02[R/W] B,H --000000	EPFR03[R/W] B,H 00000000	Extended port function register
000E64 <sub>H</sub>	EPFR04[R/W] B,H 00000000	EPFR05[R/W] B,H 00000000	EPFR06[R/W] B,H -----00	EPFR07[R/W] B,H ----0000	
000E68 <sub>H</sub>	EPFR08[R/W] B,H ----0000	EPFR09[R/W] B,H -----0	EPFR10[R/W] B,H 00000000	EPFR11[R/W] B,H ----0000	
000E6C <sub>H</sub>	EPFR12[R/W] B,H --000000	EPFR13[R/W] B,H -----1	EPFR14[R/W] B,H -0000000	EPFR15[R/W] B,H -0000000	
000E70 <sub>H</sub>	EPFR16[R/W] B,H --000000	EPFR17[R/W] B,H 00000000	EPFR18[R/W] B,H 00000000	EPFR19[R/W] B,H 00000000	
000E74 <sub>H</sub>	EPFR20[R/W] B,H 00000000	EPFR21[R/W] B,H 00000000	EPFR22[R/W] B,H 00000000	EPFR23[R/W] B,H 00000000	
000E78 <sub>H</sub>	EPFR24[R/W] B,H 00000000	EPFR25[R/W] B,H 00000000	EPFR26[R/W] B,H 00000000	EPFR27[R/W] B,H 00000000	
000E7C <sub>H</sub>	EPFR28[R/W] B,H 00000000	EPFR29[R/W] B,H 00000000	EPFR30[R/W] B,H 00000000	EPFR31[R/W] B,H 00000000	
000E80 <sub>H</sub>	EPFR32[R/W] B,H 00000000	-	-	-	

# MB91580L Series

Address	Address offset value/Register name				Block
	+0	+1	+2	+3	
000E84 <sub>H</sub>   000EBC <sub>H</sub>	-	-	-	-	Reserved
000EC0 <sub>H</sub>	PPER00[R/W] B,H 00000000	PPER01[R/W] B,H 00000000	PPER02[R/W] B,H 00000000	PPER03[R/W] B,H 00000000	Port pull-up/down enable register
000EC4 <sub>H</sub>	PPER04[R/W] B,H ----000	-	PPER06[R/W] B,H 00000000	PPER07[R/W] B,H 00000000	
000EC8 <sub>H</sub>	PPER08[R/W] B,H 00000000	PPER09[R/W] B,H 00000000	PPER10[R/W] B,H 00000000	PPER11[R/W] B,H 00000000	
000ECC <sub>H</sub>	PPER12[R/W] B,H 00000000	PPER13[R/W] B,H 00-00000	-	-	
000ED0 <sub>H</sub>   000EDC <sub>H</sub>	-	-	-	-	Reserved
000EE0 <sub>H</sub>	PILR00[R/W] B,H 11111111	PILR01[R/W] B,H 11111111	PILR02[R/W] B,H 11111111	PILR03[R/W] B,H 11111111	Port input level selection register
000EE4 <sub>H</sub>	PILR04[R/W] B,H ----111	-	PILR06[R/W] B,H 11111111	PILR07[R/W] B,H 11111111	
000EE8 <sub>H</sub>	PILR08[R/W] B,H 11111111	PILR09[R/W] B,H 11111111	PILR10[R/W] B,H 11111111	PILR11[R/W] B,H 11111111	
000EEC <sub>H</sub>	PILR12[R/W] B,H 11111111	PILR13[R/W] B,H 11-11111	-	-	
000EF0 <sub>H</sub>   000EFC <sub>H</sub>	-	-	-	-	Reserved
000F00 <sub>H</sub>   000F1C <sub>H</sub>	-	-	-	-	Reserved
000F20 <sub>H</sub>	PODR00[R/W] B,H 00000000	PODR01[R/W] B,H 00000000	PODR02[R/W] B,H 00000000	PODR03[R/W] B,H 00000000	Port output drive register
000F24 <sub>H</sub>	PODR04[R/W] B,H ----000	-	PODR06[R/W] B,H 00000000	PODR07[R/W] B,H 00000000	
000F28 <sub>H</sub>	PODR08[R/W] B,H 00000000	PODR09[R/W] B,H 00000000	PODR10[R/W] B,H 00000000	PODR11[R/W] B,H 00000000	
000F2C <sub>H</sub>	PODR12[R/W] B,H 00000000	PODR13[R/W] B,H 00-00000	-	-	
000F30 <sub>H</sub>   000F3C <sub>H</sub>	-	-	-	-	Reserved
000F40 <sub>H</sub>	PORTEN[R/W] B,H,W -----00	-	-	-	Port input enable register
000F44 <sub>H</sub>	KEYCDR[R/W] H 00000000 00000000		-	-	Port key code
000F48 <sub>H</sub>	ADERH[R/W] B,H ----- 11111111		ADERL[R/W] B,H 11111111 11111111		Analog input enable register
000F4C <sub>H</sub>	-	-	-	-	Reserved
000F50 <sub>H</sub>   000FFC <sub>H</sub>	-	-	-	-	Reserved



# MB91580L Series

Address	Address offset value/Register name				Block
	+0	+1	+2	+3	
001000 <sub>H</sub>	SACR[R/W] B,H,W -----0	PICD[R/W] B,H,W ----0011	-	-	Synchronous/asynchronous switch control
001004 <sub>H</sub>   0010BC <sub>H</sub>	-	-	-	-	Reserved
0010C0 <sub>H</sub>	-	-	-	CRCCR[R/W] B,H,W -0000000	CRC arithmetic operation
0010C4 <sub>H</sub>	CRCINT[R/W] B,H,W 11111111 11111111 11111111 11111111				
0010C8 <sub>H</sub>	CRCIN[R/W] B,H,W 00000000 00000000 00000000 00000000				
0010CC <sub>H</sub>	CRCR[R] B,H,W 11111111 11111111 11111111 11111111				
0010D0 <sub>H</sub>   0010FC <sub>H</sub>	-	-	-	-	Reserved
001100 <sub>H</sub>	TCGS[R/W] B,H,W -----00	-	-	TCGSE[R/W] B,H,W --000000	Free-run timer simultaneous activation
001104 <sub>H</sub>	CPCLRB0/CPCLR0[R/W] H,W 11111111 11111111	TCDT0[R/W] H,W 00000000 00000000		Free-run timer 0	
001108 <sub>H</sub>	TCCS0[R/W] B,H,W 00000000 01000000 ----0000 -----				
00110C <sub>H</sub>	CPCLRB1/CPCLR1[R/W] H,W 11111111 11111111	TCDT1[R/W] H,W 00000000 00000000		Free-run timer 1	
001110 <sub>H</sub>	TCCS1[R/W] B,H,W 00000000 01000000 ----0000 -----				
001114 <sub>H</sub>	CPCLRB2/CPCLR2[R/W] H,W 11111111 11111111	TCDT2[R/W] H,W 00000000 00000000		Free-run timer 2	
001118 <sub>H</sub>	TCCS2[R/W] B,H,W 00000000 01000000 ----0000 -----				
00111C <sub>H</sub>	CPCLRB3/CPCLR3[R/W] H,W 11111111 11111111	TCDT3[R/W] H,W 00000000 00000000		Free-run timer 3	
001120 <sub>H</sub>	TCCS3[R/W] B,H,W 00000000 01000000 ----0000 -----				
001124 <sub>H</sub>	CPCLRB4/CPCLR4[R/W] H,W 11111111 11111111	TCDT4[R/W] H,W 00000000 00000000		Free-run timer 4	
001128 <sub>H</sub>	TCCS4[R/W] B,H,W 00000000 01000000 ----0000 -----				
00112C <sub>H</sub>	CPCLRB5/CPCLR5[R/W] H,W 11111111 11111111	TCDT5[R/W] H,W 00000000 00000000		Free-run timer 5	
001130 <sub>H</sub>	TCCS5[R/W] B,H,W 00000000 01000000 ----0000 -----				

# MB91580L Series

Address	Address offset value/Register name				Block
	+0	+1	+2	+3	
001134 <sub>H</sub>	FRS0[R/W] B,H,W ----- -000-000 -000-000 -000-000				Free-run timer selection
001138 <sub>H</sub>	FRS1[R/W] B,H,W ----- -000-000 -000-000				
00113C <sub>H</sub>	FRS2[R/W] B,H,W ----- -000-000 -000-000 -000-000				
001140 <sub>H</sub>	FRS3[R/W] B,H,W ----- -000-000 -000-000				
001144 <sub>H</sub>	FRS4[R/W] B,H,W -000-000 -000-000 -000-000 -000-000				
001148 <sub>H</sub>	FRS5[R/W] B,H,W -000-000 -000-000 -000-000 -000-000				
00114C <sub>H</sub>	FRS6[R/W] B,H,W -000-000 -000-000 -000-000 -000-000				
001150 <sub>H</sub>	-				
001154 <sub>H</sub>	OCCPB0/OCCP0[R/W] H,W 00000000 00000000		OCCPB1/OCCP1[R/W] H,W 00000000 00000000		Output compare 0/1
001158 <sub>H</sub>	OCS01[R/W] B,H,W -110--00 00001100		-	OCMOD01[R/W] B,H,W -----00	
00115C <sub>H</sub>	OCCPB2/OCCP2[R/W] H,W 00000000 00000000		OCCPB3/OCCP3[R/W] H,W 00000000 00000000		Output compare 2/3
001160 <sub>H</sub>	OCS23[R/W] B,H,W -110--00 00001100		-	OCMOD23[R/W] B,H,W -----00	
001164 <sub>H</sub>	OCCPB4/OCCP4[R/W] H,W 00000000 00000000		OCCPB5/OCCP5[R/W] H,W 00000000 00000000		Output compare 4/5
001168 <sub>H</sub>	OCS45[R/W] B,H,W -110--00 00001100		-	OCMOD45[R/W] B,H,W -----00	
00116C <sub>H</sub>	OCCPB6/OCCP6[R/W] H,W 00000000 00000000		OCCPB7/OCCP7[R/W] H,W 00000000 00000000		Output compare 6/7
001170 <sub>H</sub>	OCS67[R/W] B,H,W -110--00 00001100		-	OCMOD67[R/W] B,H,W -----00	
001174 <sub>H</sub>	OCCPB8/OCCP8[R/W] H,W 00000000 00000000		OCCPB9/OCCP9[R/W] H,W 00000000 00000000		Output compare 8/9
001178 <sub>H</sub>	OCS89[R/W] B,H,W -110--00 00001100		-	OCMOD89[R/W] B,H,W -----00	
00117C <sub>H</sub>	OCCPB10/OCCP10[R/W] H,W 00000000 00000000		OCCPB11/OCCP11[R/W] H,W 00000000 00000000		Output compare 10/11
001180 <sub>H</sub>	OCS1011[R/W] B,H,W -110--00 00001100		-	OCMOD1011 [R/W] B,H,W -----00	
001184 <sub>H</sub>	IPCP0[R] H,W 00000000 00000000		IPCP1[R] H,W 00000000 00000000		Input capture 0/1
001188 <sub>H</sub>	ICS01[R/W] B,H,W -----00 00000000		-	LSYNS[R/W] B,H,W ---00000	
00118C <sub>H</sub>	IPCP2[R] H,W 00000000 00000000		IPCP3[R] H,W 00000000 00000000		Input capture 2/3
001190 <sub>H</sub>	ICS23[R/W] B,H,W -----00 00000000		-	-	

# MB91580L Series

Address	Address offset value/Register name				Block
	+0	+1	+2	+3	
001194 <sub>H</sub>	IPCP4[R] H,W 00000000 00000000		IPCP5[R] H,W 00000000 00000000		Input capture 4/5
001198 <sub>H</sub>	ICS45[R/W] B,H,W -----00 00000000		-	-	
00119C <sub>H</sub>	IPCP6[R] H,W 00000000 00000000		IPCP7[R] H,W 00000000 00000000		Input capture 6/7
0011A0 <sub>H</sub>	ICS67[R/W] B,H,W -----00 00000000		-	-	
0011A4 <sub>H</sub>	DTSR[R/W] B,H,W -----10	-	-	-	DTTI selection
0011A8 <sub>H</sub>	TMRR0[R/W] H,W 00000000 00000001		TMRR1[R/W] H,W 00000000 00000001		Waveform generator 0/1/2
0011AC <sub>H</sub>	TMRR2[R/W] H,W 00000000 00000001		-	-	
0011B0 <sub>H</sub>	DTSCR0[R/W] B,H,W 00000000	DTSCR1[R/W] B,H,W 00000000	DTSCR2[R/W] B,H,W 00000000	-	
0011B4 <sub>H</sub>	-	DTIR0[R/W] B,H,W 000000--	-	DTMNS0[R/W] B,H,W 00---000	
0011B8 <sub>H</sub>	-	SIGCR10[R/W] B,H,W 00000000	-	SIGCR20[R/W] B,H,W 000000-1	
0011BC <sub>H</sub>	PICS0[R/W] B,H,W 000000-- -----				
0011C0 <sub>H</sub>	TMRR3[R/W] H,W 00000000 00000001		TMRR4[R/W] H,W 00000000 00000001		
0011C4 <sub>H</sub>	TMRR5[R/W] H,W 00000000 00000001		-	-	Waveform generator 3/4/5
0011C8 <sub>H</sub>	DTSCR3[R/W] B,H,W 00000000	DTSCR4[R/W] B,H,W 00000000	DTSCR5[R/W] B,H,W 00000000	-	
0011CC <sub>H</sub>	-	DTIR1[R/W] B,H,W 000000--	-	DTMNS1[R/W] B,H,W 00---000	
0011D0 <sub>H</sub>	-	SIGCR11[R/W] B,H,W 00000000	-	SIGCR21[R/W] B,H,W 000000-1	
0011D4 <sub>H</sub>	PICS1[R/W] B,H,W 000000-- -----				
0011D8 <sub>H</sub>	-	-	-	-	12-bit A/D converter
0011DC <sub>H</sub>	ADTSS[R/W] B,H,W -----0	-	-	-	
0011E0 <sub>H</sub>	ADTSE[R/W] B,H,W ----- 00000000 00000000 00000000				
0011E4 <sub>H</sub>	ADCOMP0/ADCOMPB0[R/W] H,W 00000000 00000000		ADCOMP1/ADCOMPB1[R/W] H,W 00000000 00000000		
0011E8 <sub>H</sub>	ADCOMP2/ADCOMPB2[R/W] H,W 00000000 00000000		ADCOMP3/ADCOMPB3[R/W] H,W 00000000 00000000		
0011EC <sub>H</sub>	ADCOMP4/ADCOMPB4[R/W] H,W 00000000 00000000		ADCOMP5/ADCOMPB5[R/W] H,W 00000000 00000000		

# MB91580L Series

Address	Address offset value/Register name				Block
	+0	+1	+2	+3	
0011F0 <sub>H</sub>	ADCOMP6/ADCOMPB6[R/W] H,W 00000000 00000000		ADCOMP7/ADCOMPB7[R/W] H,W 00000000 00000000		12-bit A/D converter
0011F4 <sub>H</sub>	ADCOMP8/ADCOMPB8[R/W] H,W 00000000 00000000		ADCOMP9/ADCOMPB9[R/W] H,W 00000000 00000000		
0011F8 <sub>H</sub>	ADCOMP10/ADCOMPB10[R/W] H,W 00000000 00000000		ADCOMP11/ADCOMPB11[R/W] H,W 00000000 00000000		
0011FC <sub>H</sub>	ADCOMP12/ADCOMPB12[R/W] H,W 00000000 00000000		ADCOMP13/ADCOMPB13[R/W] H,W 00000000 00000000		
001200 <sub>H</sub>	ADCOMP14/ADCOMPB14[R/W] H,W 00000000 00000000		ADCOMP15/ADCOMPB15[R/W] H,W 00000000 00000000		
001204 <sub>H</sub>	ADCOMP16/ADCOMPB16[R/W] H,W 00000000 00000000		ADCOMP17/ADCOMPB17[R/W] H,W 00000000 00000000		
001208 <sub>H</sub>	ADCOMP18/ADCOMPB18[R/W] H,W 00000000 00000000		ADCOMP19/ADCOMPB19[R/W] H,W 00000000 00000000		
00120C <sub>H</sub>	ADCOMP20/ADCOMPB20[R/W] H,W 00000000 00000000		ADCOMP21/ADCOMPB21[R/W] H,W 00000000 00000000		
001210 <sub>H</sub>	ADCOMP22/ADCOMPB22[R/W] H,W 00000000 00000000		ADCOMP23/ADCOMPB23[R/W] H,W 00000000 00000000		
001214 <sub>H</sub>	-	-	-	-	
001218 <sub>H</sub>	-	-	-	-	
00121C <sub>H</sub>	-	-	-	-	
001220 <sub>H</sub>	-	-	-	-	
001224 <sub>H</sub>	ADTCS0[R/W] B,H,W 00000000 0010-000		ADTCS1[R/W] B,H,W 00000000 0010-000		
001228 <sub>H</sub>	ADTCS2[R/W] B,H,W 00000000 0010-000		ADTCS3[R/W] B,H,W 00000000 0010-000		
00122C <sub>H</sub>	ADTCS4[R/W] B,H,W 00000000 0010-000		ADTCS5[R/W] B,H,W 00000000 0010-000		
001230 <sub>H</sub>	ADTCS6[R/W] B,H,W 00000000 0010-000		ADTCS7[R/W] B,H,W 00000000 0010-000		
001234 <sub>H</sub>	ADTCS8[R/W] B,H,W 00000000 0010-000		ADTCS9[R/W] B,H,W 00000000 0010-000		
001238 <sub>H</sub>	ADTCS10[R/W] B,H,W 00000000 0010-000		ADTCS11[R/W] B,H,W 00000000 0010-000		
00123C <sub>H</sub>	ADTCS12[R/W] B,H,W 00000000 0010-000		ADTCS13[R/W] B,H,W 00000000 0010-000		
001240 <sub>H</sub>	ADTCS14[R/W] B,H,W 00000000 0010-000		ADTCS15[R/W] B,H,W 00000000 0010-000		
001244 <sub>H</sub>	ADTCS16[R/W] B,H,W 00000000 00100000		ADTCS17[R/W] B,H,W 00000000 00100000		
001248 <sub>H</sub>	ADTCS18[R/W] B,H,W 00000000 00100000		ADTCS19[R/W] B,H,W 00000000 00100000		
00124C <sub>H</sub>	ADTCS20[R/W] B,H,W 00000000 00100000		ADTCS21[R/W] B,H,W 00000000 00100000		
001250 <sub>H</sub>	ADTCS22[R/W] B,H,W 00000000 00100000		ADTCS23[R/W] B,H,W 00000000 00100000		
001254 <sub>H</sub>	-	-	-	-	
001258 <sub>H</sub>	-	-	-	-	
00125C <sub>H</sub>	-	-	-	-	
001260 <sub>H</sub>	-	-	-	-	
001264 <sub>H</sub>	ADTCD0[R] B,H,W 10--0000 00000000		ADTCD1[R] B,H,W 10--0000 00000000		
001268 <sub>H</sub>	ADTCD2[R] B,H,W 10--0000 00000000		ADTCD3[R] B,H,W 10--0000 00000000		

# MB91580L Series

Address	Address offset value/Register name				Block
	+0	+1	+2	+3	
00126 <sub>H</sub>	ADTCD4[R] B,H,W 10--0000 00000000		ADTCD5[R] B,H,W 10--0000 00000000		12-bit A/D converter
001270 <sub>H</sub>	ADTCD6[R] B,H,W 10--0000 00000000		ADTCD7[R] B,H,W 10--0000 00000000		
001274 <sub>H</sub>	ADTCD8[R] B,H,W 10--0000 00000000		ADTCD9[R] B,H,W 10--0000 00000000		
001278 <sub>H</sub>	ADTCD10[R] B,H,W 10--0000 00000000		ADTCD11[R] B,H,W 10--0000 00000000		
00127C <sub>H</sub>	ADTCD12[R] B,H,W 10--0000 00000000		ADTCD13[R] B,H,W 10--0000 00000000		
001280 <sub>H</sub>	ADTCD14[R] B,H,W 10--0000 00000000		ADTCD15[R] B,H,W 10--0000 00000000		
001284 <sub>H</sub>	ADTCD16[R] B,H,W 10--0000 00000000		ADTCD17[R] B,H,W 10--0000 00000000		
001288 <sub>H</sub>	ADTCD18[R] B,H,W 10--0000 00000000		ADTCD19[R] B,H,W 10--0000 00000000		
00128C <sub>H</sub>	ADTCD20[R] B,H,W 10--0000 00000000		ADTCD21[R] B,H,W 10--0000 00000000		
001290 <sub>H</sub>	ADTCD22[R] B,H,W 10--0000 00000000		ADTCD23[R] B,H,W 10--0000 00000000		
001294 <sub>H</sub>	-	-	-	-	
001298 <sub>H</sub>	-	-	-	-	
00129C <sub>H</sub>	-	-	-	-	
0012A0 <sub>H</sub>	-	-	-	-	
0012A4 <sub>H</sub>	ADCS0[R/W] B,H,W 0-----		ADCH0[R] B,H,W ----000	ADMD0[R/W] B,H,W ----0000	
0012A8 <sub>H</sub>	ADCS1[R/W] B,H,W 0-----		ADCH1[R] B,H,W ----000	ADMD1[R/W] B,H,W ----0000	
0012AC <sub>H</sub>	ADCS2[R/W] B,H,W 0-----		ADCH2[R] B,H,W ----000	ADMD2[R/W] B,H,W ----0000	
0012B0 <sub>H</sub>   0012FC <sub>H</sub>	-	-	-	-	Reserved
001300 <sub>H</sub>	RDCCTR0[R/W] B,H,W 0----000	RDCCTR1[R/W] B,H,W -0000000	RDCINTR[R] B,H,W -0000000	RDCICER[R/W] B,H,W -----00	RDC
001304 <sub>H</sub>	-	RDCCTR2[R/W] B,H,W ---00000	RDCIPR[R/W] H,W ----0000 00000000		
001308 <sub>H</sub>	RDCCPR1[R/W] H,W ----0000 00000000		RDCCPR2[R/W] H,W ----0000 00000000		
00130C <sub>H</sub>	RDCCPR3[R/W] H,W -----00 00000000		RDCCPR4[R/W] H,W -----00 00000000		
001310 <sub>H</sub>	AGLDR[R] H,W 1---XXXX XXXXXXXXX		AGVLDLDR[R] H,W XXXXXXXXXX XXXXXXXXX		
001314 <sub>H</sub>	AGLDBR[R] H,W 1---XXXX XXXXXXXXX		AGVLDBR[R] H,W XXXXXXXXXX XXXXXXXXX		
001318 <sub>H</sub>	SCCIR[R/W] H,W 1---0000 00000000		-	-	
00131C <sub>H</sub>	SINDR[R] W XXXXXXXXXX XXXXXXXXX XXXXXXXXX XXXXXXXXX				

# MB91580L Series

Address	Address offset value/Register name				Block
	+0	+1	+2	+3	
001320 <sub>H</sub>	COSDR[R] W XXXXXXXXXX XXXXXXXXXXXX XXXXXXXXXXXX XXXXXXXXXXXX				RDC
001324 <sub>H</sub>	-		-		
001328 <sub>H</sub>	SINDR1[R] W XXXXXXXXXX XXXXXXXXXXXX XXXXXXXXXXXX XXXXXXXXXXXX				
00132C <sub>H</sub>	COSDR1[R] W XXXXXXXXXX XXXXXXXXXXXX XXXXXXXXXXXX XXXXXXXXXXXX				
001330 <sub>H</sub>	-		-		Reserved
001334 <sub>H</sub>   0013FC <sub>H</sub>	-	-	-	-	
001400 <sub>H</sub>	-	-	-	-	Reserved
001404 <sub>H</sub>   0014FC <sub>H</sub>	-	-	-	-	Reserved
001500 <sub>H</sub>	SCR0/(IBCR0) [R/W] B,H,W 0--00000	SMR0[R/W] B,H,W 000000-0	SSR0[R/W] B,H,W 0--00011	ESCR0/(IBSR0) [R/W] B,H,W 00000000	Multi Function Serial I/F 0 *1: Byte access is possible only for access to lower 8 bits. *2: Reserved because I <sup>2</sup> C mode is not set immediately after reset *3: Reserved because CSIO mode is not set immediately after reset *4: Reserved because LIN2.1 mode is not set immediately after reset
001504 <sub>H</sub>	-/(RDR10/(TDR10))[R/W] B,H,W -----*3		RDR00/(TDR00)[R/W] B,H,W -----0 00000000 *1		
001508 <sub>H</sub>	SACSR0[R/W] B,H,W 0---000 00000000		STMRO[R] B,H,W 00000000 00000000		
00150C <sub>H</sub>	STMCR00[R/W] B,H,W 00000000 00000000		-/(SCSCR0/SFUR0) [R/W] B,H,W -----*3,*4		
001510 <sub>H</sub>	-/(SCSTR30) [R/W] B,H,W -----*3	-/(SCSTR20) [R/W] B,H,W -----*3	-/(SCSTR10/SFLR 10) [R/W] B,H,W -----*3,*4	-/(SCSTR00/SFLR 00) [R/W] B,H,W -----*3,*4	
001514 <sub>H</sub>	-	-	-	-	
001518 <sub>H</sub>	-	-	-	-	
00151C <sub>H</sub>	BGR0[R/W] H,W 00000000 00000000		-/(ISMK0)[R/W] B,H,W -----*2	-/(ISBA0)[R/W] B,H,W -----*2	
001520 <sub>H</sub>	FCR10[R/W] B,H,W 00-00100	FCR00[R/W] B,H,W -0000000	FBYTE20[R/W] B,H,W 00000000	FBYTE10[R/W] B,H,W 00000000	

# MB91580L Series

Address	Address offset value/Register name				Block
	+0	+1	+2	+3	
001524 <sub>H</sub>	SCR1/(IBCR1) [R/W] B,H,W 0--00000	SMR1[R/W] B,H,W 000000-0	SSR1[R/W] B,H,W 0--00011	ESCR1/(IBSR1) [R/W] B,H,W 00000000	Multi Function Serial I/F 1 *1: Byte access is possible only for access to lower 8 bits. *2: Reserved because I <sup>2</sup> C mode is not set immediately after reset *3: Reserved because CSIO mode is not set immediately after reset *4: Reserved because LIN2.1 mode is not set immediately after reset
001528 <sub>H</sub>	-/(RDR11/(TDR11))[R/W] B,H,W ----- <sup>*3</sup>		RDR01/(TDR01)[R/W] B,H,W -----0 00000000 <sup>*1</sup>		
00152C <sub>H</sub>	SACSR1[R/W] B,H,W 0----000 00000000		STMR1[R] B,H,W 00000000 00000000		
001530 <sub>H</sub>	STMCR1[R/W] B,H,W 00000000 00000000		-/(SCSCR1/SFUR1) [R/W] B,H,W ----- <sup>*3,*4</sup>		
001534 <sub>H</sub>	-/(SCSTR31) [R/W] B,H,W ----- <sup>*3</sup>	-/(SCSTR21) [R/W] B,H,W ----- <sup>*3</sup>	-/(SCSTR11/SFLR1) 1) [R/W] B,H,W ----- <sup>*3,*4</sup>	-/(SCSTR01/SFLR01) 1) [R/W] B,H,W ----- <sup>*3,*4</sup>	
001538 <sub>H</sub>	-	-	-	-	
00153C <sub>H</sub>	-	-	-	TBYTE01[R/W] B,H,W 00000000	
001540 <sub>H</sub>	BGR1[R/W] H,W 00000000 00000000		-/(ISMK1)[R/W] B,H,W ----- <sup>*2</sup>	-/(ISBA1)[R/W] B,H,W ----- <sup>*2</sup>	
001544 <sub>H</sub>	FCR11[R/W] B,H,W 00-00100	FCR01[R/W] B,H,W -0000000	FBYTE21[R/W] B,H,W 00000000	FBYTE11[R/W] B,H,W 00000000	
001548 <sub>H</sub>	SCR2[R/W] B,H,W 0--00000	SMR2[R/W] B,H,W 000000-0	SSR2[R/W] B,H,W 0--00011	ESCR2[R/W] B,H,W 00000000	
00154C <sub>H</sub>	-/(RDR12/(TDR12))[R/W] B,H,W ----- <sup>*3</sup>		RDR02/(TDR02)[R/W] B,H,W -----0 00000000 <sup>*1</sup>		
001550 <sub>H</sub>	SACSR2[R/W] B,H,W 0----000 00000000		STMR2[R] B,H,W 00000000 00000000		
001554 <sub>H</sub>	STMCR2[R/W] B,H,W 00000000 00000000		-/(SCSCR2/SFUR2) [R/W] B,H,W ----- <sup>*3,*4</sup>		
001558 <sub>H</sub>	-/(SCSTR32) [R/W] B,H,W ----- <sup>*3</sup>	-/(SCSTR22) [R/W] B,H,W ----- <sup>*3</sup>	-/(SCSTR12/SFLR12) 12) [R/W] B,H,W ----- <sup>*3,*4</sup>	-/(SCSTR02/SFLR02) 12) [R/W] B,H,W ----- <sup>*3,*4</sup>	
00155C <sub>H</sub>	-	-	-	-	
001560 <sub>H</sub>	-	-	-	TBYTE02[R/W] B,H,W 00000000	
001564 <sub>H</sub>	BGR2[R/W] H,W 00000000 00000000		-	-	
001568 <sub>H</sub>	FCR12[R/W] B,H,W 00-00100	FCR02[R/W] B,H,W -0000000	FBYTE22[R/W] B,H,W 00000000	FBYTE12[R/W] B,H,W 00000000	

# MB91580L Series

Address	Address offset value/Register name				Block
	+0	+1	+2	+3	
00156 <sub>H</sub>	SCR3/(IBCR3) [R/W] B,H,W 0--00000	SMR3[R/W] B,H,W 000000-0	SSR3[R/W] B,H,W 0--00011	ESCR3/(IBSR3) [R/W] B,H,W 00000000	Multi Function Serial I/F 3 *1: Byte access is possible only for access to lower 8 bits. *2: Reserved because I <sup>2</sup> C mode is not set immediately after reset *3: Reserved because CSIO mode is not set immediately after reset *4: Reserved because LIN2.1 mode is not set immediately after reset
001570 <sub>H</sub>	-/(RDR13/(TDR13))[R/W] B,H,W ----- <sup>*3</sup>		RDR03/(TDR03)[R/W] B,H,W -----0 00000000 <sup>*1</sup>		
001574 <sub>H</sub>	SACSR3[R/W] B,H,W 0----000 00000000		STMR3[R] B,H,W 00000000 00000000		
001578 <sub>H</sub>	STMCR3[R/W] B,H,W 00000000 00000000		-/(SCSCR3/SFUR3) [R/W] B,H,W ----- <sup>*3,*4</sup>		
00157C <sub>H</sub>	-/(SCSTR33) [R/W] B,H,W ----- <sup>*3</sup>	-/(SCSTR23) [R/W] B,H,W ----- <sup>*3</sup>	-/(SCSTR13/SFLR 13) [R/W] B,H,W ----- <sup>*3,*4</sup>	-/(SCSTR03/SFLR 03) [R/W] B,H,W ----- <sup>*3,*4</sup>	
001580 <sub>H</sub>	-	-	-	-	
001584 <sub>H</sub>	-	-	-	TBYTE03[R/W] B,H,W 00000000	
001588 <sub>H</sub>	BGR3[R/W] H,W 00000000 00000000		-/(ISMK3)[R/W] B,H,W ----- <sup>*2</sup>	-/(ISBA3)[R/W] B,H,W ----- <sup>*2</sup>	
00158C <sub>H</sub>	FCR13[R/W] B,H,W 00-00100	FCR03[R/W] B,H,W -0000000	FBYTE23[R/W] B,H,W 00000000	FBYTE13[R/W] B,H,W 00000000	
001590 <sub>H</sub>	SCR4/(IBCR4) [R/W] B,H,W 0--00000	SMR4[R/W] B,H,W 000000-0	SSR4[R/W] B,H,W 0--00011	ESCR4/(IBSR4) [R/W] B,H,W 00000000	
001594 <sub>H</sub>	-/(RDR14/(TDR14))[R/W] B,H,W ----- <sup>*3</sup>		RDR04/(TDR04)[R/W] B,H,W -----0 00000000 <sup>*1</sup>		
001598 <sub>H</sub>	SACSR4[R/W] B,H,W 0----000 00000000		STMR4[R] B,H,W 00000000 00000000		
00159C <sub>H</sub>	STMCR4[R/W] B,H,W 00000000 00000000		-/(SCSCR4/SFUR4) [R/W] B,H,W ----- <sup>*3,*4</sup>		
0015A0 <sub>H</sub>	-/(SCSTR34) [R/W] B,H,W ----- <sup>*3</sup>	-/(SCSTR24) [R/W] B,H,W ----- <sup>*3</sup>	-/(SCSTR14/SFLR 14) [R/W] B,H,W ----- <sup>*3,*4</sup>	-/(SCSTR04/SFLR 04) [R/W] B,H,W ----- <sup>*3,*4</sup>	
0015A4 <sub>H</sub>	-	-/(SCSFR24)[R/W] B,H,W ----- <sup>*3</sup>	-/(SCSFR14)[R/W] B,H,W ----- <sup>*3</sup>	-/(SCSFR04)[R/W] B,H,W ----- <sup>*3</sup>	
0015A8 <sub>H</sub>	-/(TBYTE34)[R/W] B,H,W ----- <sup>*3</sup>	-/(TBYTE24)[R/W] B,H,W ----- <sup>*3</sup>	-/(TBYTE14)[R/W] B,H,W ----- <sup>*3</sup>	TBYTE04[R/W] B,H,W 00000000	
0015AC <sub>H</sub>	BGR4[R/W] H,W 00000000 00000000		-/(ISMK4)[R/W] B,H,W ----- <sup>*2</sup>	-/(ISBA4)[R/W] B,H,W ----- <sup>*2</sup>	
0015B0 <sub>H</sub>	FCR14[R/W] B,H,W 00-00100	FCR04[R/W] B,H,W -0000000	FBYTE24[R/W] B,H,W 00000000	FBYTE14[R/W] B,H,W 00000000	
0015B4 <sub>H</sub>   001FFC <sub>H</sub>	-	-	-	-	Reserved



# MB91580L Series

Address	Address offset value/Register name				Block
	+0	+1	+2	+3	
002000 <sub>H</sub>	CTRLR0[R/W] B,H,W ----- 000-0001		STATR0[R/W] B,H,W ----- 00000000		CAN 0 64msb
002004 <sub>H</sub>	ERRCNT0 [R] B,H,W 00000000 00000000		BTR0[R/W] B,H,W -0100011 00000001		
002008 <sub>H</sub>	INTR0[R] B,H,W 00000000 00000000		TESTR0[R/W] B,H,W ----- X00000--		
00200C <sub>H</sub>	BRPER0[R/W] B,H,W ----- ----0000		-		
002010 <sub>H</sub>	IF1CREQ0[R/W] B,H,W 0----- 00000001		IF1CMSK0[R/W] B,H,W ----- 00000000		
002014 <sub>H</sub>	IF1MSK20[R/W] B,H,W 11-11111 11111111		IF1MSK10[R/W] B,H,W 11111111 11111111		
002018 <sub>H</sub>	IF1ARB20[R/W] B,H,W 00000000 00000000		IF1ARB10[R/W] B,H,W 00000000 00000000		
00201C <sub>H</sub>	IF1MCTR0[R/W] B,H,W 00000000 0--0000		-		
002020 <sub>H</sub>	IF1DTA10[R/W] B,H,W 00000000 00000000		IF1DTA20[R/W] B,H,W 00000000 00000000		
002024 <sub>H</sub>	IF1DTB10[R/W] B,H,W 00000000 00000000		IF1DTB20[R/W] B,H,W 00000000 00000000		
002028 <sub>H</sub> , 00202C <sub>H</sub>	-		-		
002030 <sub>H</sub> , 002034 <sub>H</sub>	Reserved (IF1 data mirror)				
002038 <sub>H</sub> , 00203C <sub>H</sub>	-		-		
002040 <sub>H</sub>	IF2CREQ0[R/W] B,H,W 0----- 00000001		IF2CMSK0[R/W] B,H,W ----- 00000000		
002044 <sub>H</sub>	IF2MSK20[R/W] B,H,W 11-11111 11111111		IF2MSK10[R/W] B,H,W 11111111 11111111		
002048 <sub>H</sub>	IF2ARB20[R/W] B,H,W 00000000 00000000		IF2ARB10[R/W] B,H,W 00000000 00000000		
00204C <sub>H</sub>	IF2MCTR0[R/W] B,H,W 00000000 0--0000		-		
002050 <sub>H</sub>	IF2DTA10[R/W] B,H,W 00000000 00000000		IF2DTA20[R/W] B,H,W 00000000 00000000		
002054 <sub>H</sub>	IF2DTB10[R/W] B,H,W 00000000 00000000		IF2DTB20[R/W] B,H,W 00000000 00000000		
002058 <sub>H</sub> , 00205C <sub>H</sub>	-		-		
002060 <sub>H</sub> , 002064 <sub>H</sub>	Reserved (IF2 data mirror)				
002068 <sub>H</sub> ,   00207C <sub>H</sub>	-		-		
002080 <sub>H</sub>	TREQR20[R] B,H,W 00000000 00000000		TREQR10[R] B,H,W 00000000 00000000		
002084 <sub>H</sub>	TREQR40[R] B,H,W 00000000 00000000		TREQR30[R] B,H,W 00000000 00000000		
002088 <sub>H</sub>	-		-		
00208C <sub>H</sub>	-		-		
002090 <sub>H</sub>	NEWDT20[R] B,H,W 00000000 00000000		NEWDT10[R] B,H,W 00000000 00000000		
002094 <sub>H</sub>	NEWDT40[R] B,H,W 00000000 00000000		NEWDT30[R] B,H,W 00000000 00000000		

# MB91580L Series

Address	Address offset value/Register name				Block
	+0	+1	+2	+3	
002098 <sub>H</sub>	-	-	-	-	CAN 0 64msb
00209C <sub>H</sub>	-	-	-	-	
0020A0 <sub>H</sub>	INTPND20[R] B,H,W 00000000 00000000		INTPND10[R] B,H,W 00000000 00000000		
0020A4 <sub>H</sub>	INTPND40[R] B,H,W 00000000 00000000		INTPND30[R] B,H,W 00000000 00000000		
0020A8 <sub>H</sub>	-	-	-	-	
0020AC <sub>H</sub>	-	-	-	-	
0020B0 <sub>H</sub>	MSGVAL20[R] B,H,W 00000000 00000000		MSGVAL10[R] B,H,W 00000000 00000000		
0020B4 <sub>H</sub>	MSGVAL40[R] B,H,W 00000000 00000000		MSGVAL30[R] B,H,W 00000000 00000000		
0020B8 <sub>H</sub>	-	-	-	-	
0020BC <sub>H</sub>	-	-	-	-	
0020C0 <sub>H</sub>   0020FC <sub>H</sub>	-	-	-	-	
002100 <sub>H</sub>	CTRLR1[R/W] B,H,W ----- 000-0001		STATR1[R/W] B,H,W ----- 00000000		
002104 <sub>H</sub>	ERRCNT1 [R] B,H,W 00000000 00000000		BTR1[R/W] B,H,W -0100011 00000001		
002108 <sub>H</sub>	INTR1[R] B,H,W 00000000 00000000		TESTR1[R/W] B,H,W ----- X00000--		
00210C <sub>H</sub>	BRPER1[R/W] B,H,W ----- ----0000		-		
002110 <sub>H</sub>	IF1CREQ1[R/W] B,H,W 0----- 00000001		IF1CMSK1[R/W] B,H,W ----- 00000000		
002114 <sub>H</sub>	IF1MSK21[R/W] B,H,W 11-11111 11111111		IF1MSK11[R/W] B,H,W 11111111 11111111		
002118 <sub>H</sub>	IF1ARB21[R/W] B,H,W 00000000 00000000		IF1ARB11[R/W] B,H,W 00000000 00000000		
00211C <sub>H</sub>	IF1MCTR1[R/W] B,H,W 00000000 0---0000		-		
002120 <sub>H</sub>	IF1DTA11[R/W] B,H,W 00000000 00000000		IF1DTA21[R/W] B,H,W 00000000 00000000		
002124 <sub>H</sub>	IF1DTB11[R/W] B,H,W 00000000 00000000		IF1DTB21[R/W] B,H,W 00000000 00000000		
002128 <sub>H</sub> , 00212C <sub>H</sub>	-	-	-		
002130 <sub>H</sub> , 002134 <sub>H</sub>	Reserved (IF1 data mirror)				
002138 <sub>H</sub> , 00213C <sub>H</sub>	-	-	-		
002140 <sub>H</sub>	IF2CREQ1[R/W] B,H,W 0----- 00000001		IF2CMSK1[R/W] B,H,W ----- 00000000		
002144 <sub>H</sub>	IF2MSK21[R/W] B,H,W 11-11111 11111111		IF2MSK11[R/W] B,H,W 11111111 11111111		
002148 <sub>H</sub>	IF2ARB21[R/W] B,H,W 00000000 00000000		IF2ARB11[R/W] B,H,W 00000000 00000000		
00214C <sub>H</sub>	IF2MCTR1[R/W] B,H,W 00000000 0---0000		-		
002150 <sub>H</sub>	IF2DTA11[R/W] B,H,W 00000000 00000000		IF2DTA21[R/W] B,H,W 00000000 00000000		
002154 <sub>H</sub>	IF2DTB11[R/W] B,H,W 00000000 00000000		IF2DTB21[R/W] B,H,W 00000000 00000000		

# MB91580L Series

Address	Address offset value/Register name				Block
	+0	+1	+2	+3	
002158 <sub>H</sub> , 00215C <sub>H</sub>	-		-		CAN 1 64msb
002160 <sub>H</sub> , 002164 <sub>H</sub>	Reserved (IF2 data mirror)				
002168 <sub>H</sub>   00217C <sub>H</sub>	-		-		
002180 <sub>H</sub>	TREQR21[R] B,H,W 00000000 00000000		TREQR11[R] B,H,W 00000000 00000000		
002184 <sub>H</sub>	TREQR41[R] B,H,W 00000000 00000000		TREQR31[R] B,H,W 00000000 00000000		
002188 <sub>H</sub>	-		-		
00218C <sub>H</sub>	-		-		
002190 <sub>H</sub>	NEWDT21[R] B,H,W 00000000 00000000		NEWDT11[R] B,H,W 00000000 00000000		
002194 <sub>H</sub>	NEWDT41[R] B,H,W 00000000 00000000		NEWDT31[R] B,H,W 00000000 00000000		
002198 <sub>H</sub>	-		-		
00219C <sub>H</sub>	-		-		
0021A0 <sub>H</sub>	INTPND21[R] B,H,W 00000000 00000000		INTPND11[R] B,H,W 00000000 00000000		
0021A4 <sub>H</sub>	INTPND41[R] B,H,W 00000000 00000000		INTPND31[R] B,H,W 00000000 00000000		
0021A8 <sub>H</sub>	-		-		
0021AC <sub>H</sub>	-		-		
0021B0 <sub>H</sub>	MSGVAL21[R] B,H,W 00000000 00000000		MSGVAL11[R] B,H,W 00000000 00000000		
0021B4 <sub>H</sub>	MSGVAL41[R] B,H,W 00000000 00000000		MSGVAL31[R] B,H,W 00000000 00000000		
0021B8 <sub>H</sub>	-		-		
0021BC <sub>H</sub>	-		-		
0021C0 <sub>H</sub>   0021FC <sub>H</sub>	-		-		
002200 <sub>H</sub>	CTRLR2[R/W] B,H,W ----- 000-0001		STATR2[R/W] B,H,W ----- 00000000		
002204 <sub>H</sub>	ERRCNT2 [R] B,H,W 00000000 00000000		BTR2[R/W] B,H,W -0100011 00000001		
002208 <sub>H</sub>	INTR2[R] B,H,W 00000000 00000000		TESTR2[R/W] B,H,W ----- X00000--		
00220C <sub>H</sub>	BRPER2[R/W] B,H,W -----0000		-		
002210 <sub>H</sub>	IF1CREQ2[R/W] B,H,W 0----- 00000001		IF1CMSK2[R/W] B,H,W ----- 00000000		
002214 <sub>H</sub>	IF1MSK22[R/W] B,H,W 11-11111 11111111		IF1MSK12[R/W] B,H,W 11111111 11111111		
002218 <sub>H</sub>	IF1ARB22[R/W] B,H,W 00000000 00000000		IF1ARB12[R/W] B,H,W 00000000 00000000		
00221C <sub>H</sub>	IF1MCTR2[R/W] B,H,W 00000000 0---0000		-		
002220 <sub>H</sub>	IF1DTA12[R/W] B,H,W 00000000 00000000		IF1DTA22[R/W] B,H,W 00000000 00000000		
002224 <sub>H</sub>	IF1DTB12[R/W] B,H,W 00000000 00000000		IF1DTB22[R/W] B,H,W 00000000 00000000		

# MB91580L Series

Address	Address offset value/Register name				Block
	+0	+1	+2	+3	
002228 <sub>H</sub> , 00222C <sub>H</sub>	-		-		CAN 2 64msb
002230 <sub>H</sub> , 002234 <sub>H</sub>	Reserved (IF1 data mirror)				
002238 <sub>H</sub> , 00223C <sub>H</sub>	-		-		
002240 <sub>H</sub>	IF2CREQ2[R/W] B,H,W 0----- 00000001		IF2CMSK2[R/W] B,H,W ----- 00000000		
002244 <sub>H</sub>	IF2MSK22[R/W] B,H,W 11-11111 11111111		IF2MSK12[R/W] B,H,W 11111111 11111111		
002248 <sub>H</sub>	IF2ARB22[R/W] B,H,W 00000000 00000000		IF2ARB12[R/W] B,H,W 00000000 00000000		
00224C <sub>H</sub>	IF2MCTR2[R/W] B,H,W 00000000 0--0000		-		
002250 <sub>H</sub>	IF2DTA12[R/W] B,H,W 00000000 00000000		IF2DTA22[R/W] B,H,W 00000000 00000000		
002254 <sub>H</sub>	IF2DTB12[R/W] B,H,W 00000000 00000000		IF2DTB22[R/W] B,H,W 00000000 00000000		
002258 <sub>H</sub> , 00225C <sub>H</sub>	-		-		
002260 <sub>H</sub> , 002264 <sub>H</sub>	Reserved (IF2 data mirror)				
002268 <sub>H</sub>   00227C <sub>H</sub>	-		-		
002280 <sub>H</sub>	TREQR22[R] B,H,W 00000000 00000000		TREQR12[R] B,H,W 00000000 00000000		
002284 <sub>H</sub>	TREQR42[R] B,H,W 00000000 00000000		TREQR32[R] B,H,W 00000000 00000000		
002288 <sub>H</sub>	-		-		
00228C <sub>H</sub>	-		-		
002290 <sub>H</sub>	NEWDT22[R] B,H,W 00000000 00000000		NEWDT12[R] B,H,W 00000000 00000000		
002294 <sub>H</sub>	NEWDT42[R] B,H,W 00000000 00000000		NEWDT32[R] B,H,W 00000000 00000000		
002298 <sub>H</sub>	-		-		
00229C <sub>H</sub>	-		-		
0022A0 <sub>H</sub>	INTPND22[R] B,H,W 00000000 00000000		INTPND12[R] B,H,W 00000000 00000000		
0022A4 <sub>H</sub>	INTPND42[R] B,H,W 00000000 00000000		INTPND32[R] B,H,W 00000000 00000000		
0022A8 <sub>H</sub>	-		-		
0022AC <sub>H</sub>	-		-		
0022B0 <sub>H</sub>	MSGVAL22[R] B,H,W 00000000 00000000		MSGVAL12[R] B,H,W 00000000 00000000		
0022B4 <sub>H</sub>	MSGVAL42[R] B,H,W 00000000 00000000		MSGVAL32[R] B,H,W 00000000 00000000		
0022B8 <sub>H</sub>	-		-		
0022BC <sub>H</sub>	-		-		
0022C0 <sub>H</sub>   0022FC <sub>H</sub>	-	-	-	-	

# MB91580L Series

Address	Address offset value/Register name				Block
	+0	+1	+2	+3	
002300 <sub>H</sub>	DFCTLR[R/W] B,H,W -0-----		-	DFSTR[R/W] B,H,W ----001	WorkFlash
002304 <sub>H</sub>	-	-	-	-	
002308 <sub>H</sub>	FLIFCTLR[R/W] B,H,W ---0--00	-	FLIFFER1[R/W] B,H,W -----	FLIFFER2[R/W] B,H,W -----	
00230C <sub>H</sub>   002FFC <sub>H</sub>	-	-	-	-	Reserved
003000 <sub>H</sub>	SEEARX[R] B,H,W -0000000 00000000		DEEARX[R] B,H,W -0000000 00000000		XBS RAM ECC control register
003004 <sub>H</sub>	EECSRX[R/W] B,H,W ----00-0	-	EFEARX[R/W] B,H,W -0000000 00000000		
003008 <sub>H</sub>	-	EFECRX[R/W] B,H,W -----0 00000000 00000000			
00300C <sub>H</sub>	TEAR0X[R] B,H,W 000----- -0000000 00000000				XBS RAM diagnosis register
003010 <sub>H</sub>	TEAR1X[R] B,H,W 000----- -0000000 00000000				
003014 <sub>H</sub>	TEAR2X[R] B,H,W 000----- -0000000 00000000				
003018 <sub>H</sub>	TAEARX[R/W] B,H,W -1011111 11111111		TASARX[R/W] B,H,W -0000000 00000000		
00301C <sub>H</sub>	TFCRX[R/W] B,H,W ----0000	TICRX[R/W] B,H,W ----0000	TTCRX[R/W] B,H,W -----00 00001100		
003020 <sub>H</sub>	TSRCRX[R/W] B,H,W 0-----	-	-	TKCCRX[R/W] B,H,W 00----00	
003024 <sub>H</sub>	SEEARA[R] B,H,W --000000 00000000		DEEARA[R] B,H,W --000000 00000000		Backup RAM ECC control register
003028 <sub>H</sub>	EECSRA[R/W] B,H,W ----00-0	-	EFEARA[R/W] B,H,W --000000 00000000		
00302C <sub>H</sub>	-	EFECRA[R/W] B,H,W -----0 00000000 00000000			
003030 <sub>H</sub>	TEAR0A[R] B,H,W 000----- -000 00000000				Backup RAM diagnosis register
003034 <sub>H</sub>	TEAR1A[R] B,H,W 000----- -000 00000000				
003038 <sub>H</sub>	TEAR2A[R] B,H,W 000----- -000 00000000				
00303C <sub>H</sub>	TAEARA[R/W] B,H,W -----111 11111111		TASARA[R/W] B,H,W -----000 00000000		
003040 <sub>H</sub>	TFCRA[R/W] B,H,W ----0000	TICRA[R/W] B,H,W ----0000	TTCRA[R/W] B,H,W -----00 00001100		
003044 <sub>H</sub>	TSRCRA[R/W] B,H,W 0-----	-	-	TKCCRA[R/W] B,H,W 00----00	
003048 <sub>H</sub>   0030FC <sub>H</sub>	-	-	-	-	Reserved

# MB91580L Series

Address	Address offset value/Register name				Block	
	+0	+1	+2	+3		
003100 <sub>H</sub>	BUSDIGSR0[R/W] H,W 00000000 0-----00		BUSDIGSR1[R/W] H,W 00000000 0-----00		Bus diagnosis	
003104 <sub>H</sub>	BUSDIGSR2[R/W] H,W 00000000 0-----00		BUSTSTR0[R/W] H,W 00--0000 00000000			
003108 <sub>H</sub>	BUSADR0[R] W 00000000 00000000 00000000 00000000					
00310C <sub>H</sub>	BUSADR1[R] W 00000000 00000000 00000000 00000000					
003110 <sub>H</sub>	BUSADR2[R] W 00000000 00000000 00000000 00000000					
003114 <sub>H</sub>	-		BUSDIGSR3[R/W] H,W 00000000 0-----00			
003118 <sub>H</sub>	BUSDIGSR4[R/W] H,W 00000000 0-----00		BUSTSTR1[R/W] H,W 00--0000 00000000			
00311C <sub>H</sub>	-					
003120 <sub>H</sub>	BUSADR3[R] W 00000000 00000000 00000000 00000000					
003124 <sub>H</sub>	BUSADR4[R] W 00000000 00000000 00000000 00000000					
003128 <sub>H</sub>   003FFC <sub>H</sub>	-	-	-	-		Reserved
004000 <sub>H</sub>   005FFC <sub>H</sub>	Backup RAM					Backup RAM area
006000 <sub>H</sub>   00CFFC <sub>H</sub>	-	-	-	-		Reserved
00D000 <sub>H</sub>	CIF0[R] W 00000100 11111111 01011011 11111111				FlexRay CIF	
00D004 <sub>H</sub>	CIF1[R/W] W 00000000 -----0 -0000000 -----					
00D008 <sub>H</sub>   00D00C <sub>H</sub>	-	-	-	-	Reserved	
00D010 <sub>H</sub>	-				FlexRay GIF	
00D014 <sub>H</sub>	-					
00D018 <sub>H</sub>	-	-	-	-		
00D01C <sub>H</sub>	LCK[R/W] W -----00000000				FlexRay INT	
00D020 <sub>H</sub>	EIR[R/W] W ----000 ----000 ----0000 00000000					
00D024 <sub>H</sub>	SIR[R/W] W ----00 ----00 00000000 00000000					
00D028 <sub>H</sub>	EILS[R/W] W ----000 ----000 ----0000 00000000					
00D02C <sub>H</sub>	SILS[R/W] W ----11 ----11 11111111 11111111					
00D030 <sub>H</sub>	EIES[R/W] W ----000 ----000 ----0000 00000000					
00D034 <sub>H</sub>	EIER[R/W] W ----000 ----000 ----0000 00000000					
00D038 <sub>H</sub>	SIES[R/W] W ----00 ----00 00000000 00000000					

# MB91580L Series

Address	Address offset value/Register name				Block
	+0	+1	+2	+3	
00D03C <sub>H</sub>	SIER[R/W] W -----00 -----00 00000000 00000000				FlexRay INT
00D040 <sub>H</sub>	ILE[R/W] W -----00				
00D044 <sub>H</sub>	T0C[R/W] W --000000 00000000 -00000000 -----00				
00D048 <sub>H</sub>	T1C[R/W] W --000000 00000010 -----00				
00D04C <sub>H</sub>	STPW1[R/W] W --000000 00000000 --000000 -00000000				
00D050 <sub>H</sub>	STPW2[R] W -----000 00000000 -----000 00000000				
00D054 <sub>H</sub>   00D07C <sub>H</sub>	-	-	-	-	Reserved
00D080 <sub>H</sub>	SUCC1[R/W] W ----1100 01000000 00010-00 1---0000				FlexRay SUC
00D084 <sub>H</sub>	SUCC2[R/W] W ---0001 ---00000 00000101 00000100				
00D088 <sub>H</sub>	SUCC3[R/W] W -----00010001				
00D08C <sub>H</sub>	NEMC[R/W] W -----0000				FlexRay NEM
00D090 <sub>H</sub>	PRTC1[R/W] W 000010-0 01001100 0000-110 00110011				FlexRay PRT
00D094 <sub>H</sub>	PRTC2[R/W] W --001111 00101101 --001010 --001110				
00D098 <sub>H</sub>	MHDC[R/W] W ---00000 00000000 -----00000000				FlexRay MHD
00D09C <sub>H</sub>	-				Reserved
00D0A0 <sub>H</sub>	GTUC1[R/W] W -----0000 00000010 10000000				FlexRay GTU
00D0A4 <sub>H</sub>	GTUC2[R/W] W -----0010 --000000 00001010				
00D0A8 <sub>H</sub>	GTUC3[R/W] W -0000010 -0000010 00000000 00000000				
00D0AC <sub>H</sub>	GTUC4[R/W] W --000000 00001000 --000000 00000111				
00D0B0 <sub>H</sub>	GTUC5[R/W] W 00001110 ---00000 00000000 00000000				
00D0B4 <sub>H</sub>	GTUC6[R/W] W ----000 00000010 ----000 00000000				
00D0B8 <sub>H</sub>	GTUC7[R/W] W ----00 00000010 -----00 00000100				
00D0BC <sub>H</sub>	GTUC8[R/W] W ---00000 00000000 -----0000010				
00D0C0 <sub>H</sub>	GTUC9[R/W] W -----00 ---00001 --000001				
00D0C4 <sub>H</sub>	GTUC10[R/W] W ----000 00000010 --000000 00000101				
00D0C8 <sub>H</sub>	GTUC11[R/W] W ----000 -----000 -----00 -----00				
00D0CC <sub>H</sub>   00D0FC <sub>H</sub>	-				Reserved

# MB91580L Series

Address	Address offset value/Register name				Block
	+0	+1	+2	+3	
00D100 <sub>H</sub>	CCSV[R] W --000000 00010000 -100--00 00000000				FlexRay SUC
00D104 <sub>H</sub>	CCEV[R] W -----000000 00--0000				
00D108 <sub>H</sub> 00D10C <sub>H</sub>	-				Reserved
00D110 <sub>H</sub>	SCV[R] W ----000 00000000 ----000 00000000				FlexRay GTU
00D114 <sub>H</sub>	MTCCV[R] W -----0000000 --0000000 00000000				
00D118 <sub>H</sub>	RCV[R] W -----00000000 ----0000 00000000				
00D11C <sub>H</sub>	OCV[R] W -----000 00000000 00000000				
00D120 <sub>H</sub>	SFS[R] W -----0000 00000000 00000000				
00D124 <sub>H</sub>	SWNIT[R] W -----00000000 ----0000 00000000				
00D128 <sub>H</sub>	ACS[R/W] W -----00000000 ----000000				
00D12C <sub>H</sub>	-				
00D130 <sub>H</sub>	ESID1[R] W -----00----00 00000000				
00D134 <sub>H</sub>	ESID2[R] W -----00----00 00000000				
00D138 <sub>H</sub>	ESID3[R] W -----00----00 00000000				
00D13C <sub>H</sub>	ESID4[R] W -----00----00 00000000				
00D140 <sub>H</sub>	ESID5[R] W -----00----00 00000000				
00D144 <sub>H</sub>	ESID6[R] W -----00----00 00000000				
00D148 <sub>H</sub>	ESID7[R] W -----00----00 00000000				
00D14C <sub>H</sub>	ESID8[R] W -----00----00 00000000				
00D150 <sub>H</sub>	ESID9[R] W -----00----00 00000000				
00D154 <sub>H</sub>	ESID10[R] W -----00----00 00000000				
00D158 <sub>H</sub>	ESID11[R] W -----00----00 00000000				
00D15C <sub>H</sub>	ESID12[R] W -----00----00 00000000				
00D160 <sub>H</sub>	ESID13[R] W -----00----00 00000000				
00D164 <sub>H</sub>	ESID14[R] W -----00----00 00000000				
00D168 <sub>H</sub>	ESID15[R] W -----00----00 00000000				
00D16C <sub>H</sub>	-				
00D170 <sub>H</sub>	OSID1[R] W -----00----00 00000000				



# MB91580L Series

Address	Address offset value/Register name				Block
	+0	+1	+2	+3	
00D174 <sub>H</sub>			OSID2[R] W		FlexRay GTU
		-----	00----00 00000000		
00D178 <sub>H</sub>			OSID3[R] W		
		-----	00----00 00000000		
00D17C <sub>H</sub>			OSID4[R] W		
		-----	00----00 00000000		
00D180 <sub>H</sub>			OSID5[R] W		
		-----	00----00 00000000		
00D184 <sub>H</sub>			OSID6[R] W		
		-----	00----00 00000000		
00D188 <sub>H</sub>			OSID7[R] W		
		-----	00----00 00000000		
00D18C <sub>H</sub>			OSID8[R] W		
		-----	00----00 00000000		
00D190 <sub>H</sub>			OSID9[R] W		
		-----	00----00 00000000		
00D194 <sub>H</sub>			OSID10[R] W		
		-----	00----00 00000000		
00D198 <sub>H</sub>			OSID11[R] W		
		-----	00----00 00000000		
00D19C <sub>H</sub>			OSID12[R] W		
		-----	00----00 00000000		
00D1A0 <sub>H</sub>			OSID13[R] W		
		-----	00----00 00000000		
00D1A4 <sub>H</sub>			OSID14[R] W		
		-----	00----00 00000000		
00D1A8 <sub>H</sub>			OSID15[R] W		
		-----	00----00 00000000		
00D1AC <sub>H</sub>			-		Reserved
00D1B0 <sub>H</sub>			NMV1[R] W		FlexRay NEM
		00000000 00000000 00000000 00000000			
00D1B4 <sub>H</sub>			NMV2[R] W		
		00000000 00000000 00000000 00000000			
00D1B8 <sub>H</sub>			NMV3[R] W		
		00000000 00000000 00000000 00000000			
00D1BC <sub>H</sub>   00D2FC <sub>H</sub>			-		Reserved
00D300 <sub>H</sub>			MRC[R/W] W		FlexRay MHD
		-----001 10000000 00000000 00000000			
00D304 <sub>H</sub>			FRF[R/W] W		
		-----1 10000000 ---00000 00000000			
00D308 <sub>H</sub>			FRFM[R/W] W		
		-----	---00000 000000--		
00D30C <sub>H</sub>			FCL[R/W] W		
		-----	10000000		
00D310 <sub>H</sub>			MHDS[R/W] W		
		-0000000 -00000000 -00000000 10000000			
00D314 <sub>H</sub>			LDS[R] W		
		-----000 00000000 -----000 00000000			
00D318 <sub>H</sub>			FSR[R] W		
		-----	00000000 -----000		
00D31C <sub>H</sub>			MHDF[R/W] W		
		-----	-----0 00000000		

# MB91580L Series

Address	Address offset value/Register name				Block
	+0	+1	+2	+3	
00D320 <sub>H</sub>	TXRQ1[R] W 00000000 00000000 00000000 00000000				FlexRay MHD
00D324 <sub>H</sub>	TXRQ2[R] W 00000000 00000000 00000000 00000000				
00D328 <sub>H</sub>	TXRQ3[R] W 00000000 00000000 00000000 00000000				
00D32C <sub>H</sub>	TXRQ4[R] W 00000000 00000000 00000000 00000000				
00D330 <sub>H</sub>	NDAT1[R] W 00000000 00000000 00000000 00000000				
00D334 <sub>H</sub>	NDAT2[R] W 00000000 00000000 00000000 00000000				
00D338 <sub>H</sub>	NDAT3[R] W 00000000 00000000 00000000 00000000				
00D33C <sub>H</sub>	NDAT4[R] W 00000000 00000000 00000000 00000000				
00D340 <sub>H</sub>	MBSC1[R] W 00000000 00000000 00000000 00000000				
00D344 <sub>H</sub>	MBSC2[R] W 00000000 00000000 00000000 00000000				
00D348 <sub>H</sub>	MBSC3[R] W 00000000 00000000 00000000 00000000				
00D34C <sub>H</sub>	MBSC4[R] W 00000000 00000000 00000000 00000000				
00D350 <sub>H</sub>   00D3EC <sub>H</sub>	-				Reserved
00D3F0 <sub>H</sub>	CREL[R] W 00010000 00111001 00000010 00000110				FlexRay GIF
00D3F4 <sub>H</sub>	ENDN[R] W 10000111 01100101 01000011 00100001				
00D3F8 <sub>H</sub>   00D3FC <sub>H</sub>	-				Reserved
00D400 <sub>H</sub>   00D4FC <sub>H</sub>	WRDS <sub>n</sub> [1-64][R/W] W 00000000 00000000 00000000 00000000				FlexRay IBF
00D500 <sub>H</sub>	WRHS1[R/W] W --000000 -00000000 -----000 00000000				
00D504 <sub>H</sub>	WRHS2[R/W] W ----- -00000000 -----000 00000000				
00D508 <sub>H</sub>	WRHS3[R/W] W ----- -----000 00000000				
00D50C <sub>H</sub>	-				
00D510 <sub>H</sub>	IBCM[R/W] W ----- --00 ----- --000				
00D514 <sub>H</sub>	IBCR[R/W] W 0----- -00000000 0----- -00000000				
00D518 <sub>H</sub>   00D5FC <sub>H</sub>	-				Reserved

# MB91580L Series

Address	Address offset value/Register name				Block
	+0	+1	+2	+3	
00D600 <sub>H</sub>   00D6FC <sub>H</sub>	RDDS <sub>n</sub> [1-64][R] W 00000000 00000000 00000000 00000000				FlexRay OBF
00D700 <sub>H</sub>	RDHS1[R] W --000000 -0000000 -000 00000000				
00D704 <sub>H</sub>	RDHS2[R] W -0000000 -0000000 -000 00000000				
00D708 <sub>H</sub>	RDHS3[R] W --000000 -0000000 -000 00000000				
00D70C <sub>H</sub>	MBS[R] W --000000 -0000000 00-000000 00000000				
00D710 <sub>H</sub>	OBCM[R/W] W -----00 -----00				
00D714 <sub>H</sub>	OBCR[R/W] W -----0000000 0-----00 -0000000				
00D718 <sub>H</sub>   00D7FC <sub>H</sub>	-				Reserved
00D800 <sub>H</sub>   00EFC <sub>H</sub>	-				Reserved
00F000 <sub>H</sub>   00FEFC <sub>H</sub>	-				Reserved [S]
00FF00 <sub>H</sub>	DSUCR[R/W] B,H,W -----0		-	-	OCDU [S]
00FF04 <sub>H</sub>   00FF0C <sub>H</sub>	-	-	-	-	Reserved [S]
00FF10 <sub>H</sub>	PCSR[R/W] B,H,W XXXXXXXXXXXXXXXXXXXXXXXXXXXXXXXX				OCDU [S]
00FF14 <sub>H</sub>	PSSR[R/W] B,H,W XXXXXXXXXXXXXXXXXXXXXXXXXXXXXXXX				
00FF18 <sub>H</sub>   00FFF4 <sub>H</sub>	-	-	-	-	Reserved [S]
00FFF8 <sub>H</sub>	EDIR1[R] B,H,W XXXXXXXXXXXXXXXXXXXXXXXXXXXXXXXX				OCDU [S]
00FFFC <sub>H</sub>	EDIR0[R] B,H,W XXXXXXXXXXXXXXXXXXXXXXXXXXXXXXXX				

[S]: It is a system register. The illegal instruction exception (data access error) is generated when reading and writing to these registers in the user mode.

# MB91580L Series

• MB91F585LB/F586LB/F587LB/F585LD/F586LD/F587LD

Address	Address offset value/Register name				Block
	+0	+1	+2	+3	
000000 <sub>H</sub>	PDR00[R/W] B,H,W XXXXXXXXXX	PDR01[R/W] B,H,W XXXXXXXXXX	PDR02[R/W] B,H,W XXXXXXXXXX	PDR03[R/W] B,H,W XXXXXXXXXX	Port data register
000004 <sub>H</sub>	PDR04[R/W] B,H,W XXXXXXXXXX	PDR05[R/W] B,H,W XXXXXXXXXX	PDR06[R/W] B,H,W XXXXXXXXXX	PDR07[R/W] B,H,W XXXXXXXXXX	
000008 <sub>H</sub>	PDR08[R/W] B,H,W XXXXXXXXXX	PDR09[R/W] B,H,W XXXXXXXXXX	PDR10[R/W] B,H,W XXXXXXXXXX	PDR11[R/W] B,H,W XXXXXXXXXX	
00000C <sub>H</sub>	PDR12[R/W] B,H,W XXXXXXXXXX	PDR13[R/W] B,H,W XX-XXXXX	-	-	
000010 <sub>H</sub>   000038 <sub>H</sub>	-	-	-	-	Reserved
00003C <sub>H</sub>	WDTCR0[R/W] B,H,W -0--0000	WDTCPR0[W] B,H,W 00000000	WDTCR1[R] B,H,W ----0010	WDTCPR1[W] B,H,W 00000000	Watchdog timer [S]
000040 <sub>H</sub>	-	-	-	-	Reserved
000044 <sub>H</sub>	DICR[R/W] B -----0	-	-	-	Delay interrupt
000048 <sub>H</sub>   00005C <sub>H</sub>	-	-	-	-	Reserved
000060 <sub>H</sub>	TMRLRA0[R/W] H XXXXXXXXXX XXXXXXXXX		TMR0[R] H XXXXXXXXXX XXXXXXXXX		Reload timer 0
000064 <sub>H</sub>	TMRLRB0[R/W] H XXXXXXXXXX XXXXXXXXX		TMCSR0[R/W] B,H,W 00000000 0-000000		
000068 <sub>H</sub>   00007C <sub>H</sub>	-	-	-	-	Reserved
000080 <sub>H</sub>	BT0TMR[R] H 00000000 00000000		BT0TMCR[R/W] H -0000000 00000000		Base timer 0
000084 <sub>H</sub>	BT0TMCR2 [R/W] B -----0	BT0STC [R/W] B -0-0-0-0	-	-	
000088 <sub>H</sub>	BT0PCSR/BT0PRL [R/W] H 00000000 00000000		BT0PDUT/BT0PRLH/BT0DTBF [R/W] H 00000000 00000000		
00008C <sub>H</sub>	-	-	-	-	
000090 <sub>H</sub>	BT1TMR[R] H 00000000 00000000		BT1TMCR[R/W] H -0000000 00000000		Base timer 1
000094 <sub>H</sub>	BT1TMCR2 [R/W] B -----0	BT1STC [R/W] B -0-0-0-0	-	-	
000098 <sub>H</sub>	BT1PCSR/BT1PRL [R/W] H 00000000 00000000		BT1PDUT/BT1PRLH/BT1DTBF [R/W] H 00000000 00000000		
00009C <sub>H</sub>	BTSEL01[R/W] B ----0000	-	BTSSSR[W] B,H -----11		
0000A0 <sub>H</sub>   0000FC <sub>H</sub>	-	-	-	-	Reserved

# MB91580L Series

Address	Address offset value/Register name				Block
	+0	+1	+2	+3	
000100 <sub>H</sub>	TMRLRA1[R/W] H XXXXXXXXXX XXXXXXXXXX		TMR1[R] H XXXXXXXXXX XXXXXXXXXX		Reload timer 1
000104 <sub>H</sub>	TMRLRB1[R/W] H XXXXXXXXXX XXXXXXXXXX		TMCSR1[R/W] B,H,W 00000000 0-000000		
000108 <sub>H</sub>	TMRLRA2[R/W] H XXXXXXXXXX XXXXXXXXXX		TMR2[R] H XXXXXXXXXX XXXXXXXXXX		Reload timer 2
00010C <sub>H</sub>	TMRLRB2[R/W] H XXXXXXXXXX XXXXXXXXXX		TMCSR2[R/W] B,H,W 00000000 0-000000		
000110 <sub>H</sub>	TMRLRA3[R/W] H XXXXXXXXXX XXXXXXXXXX		TMR3[R] H XXXXXXXXXX XXXXXXXXXX		Reload timer 3
000114 <sub>H</sub>	TMRLRB3[R/W] H XXXXXXXXXX XXXXXXXXXX		TMCSR3[R/W] B,H,W 00000000 0-000000		
000118 <sub>H</sub>   00011C <sub>H</sub>	-	-	-	-	Reserved
000120 <sub>H</sub>	IRPR0H[R] B,H,W 00-----	IRPR0L[R] B,H,W 00-----	IRPR1H[R] B,H,W 00-----	IRPR1L[R] B,H,W -----	Interrupt request batch read register
000124 <sub>H</sub>	IRPR2H[R] B,H,W -----	IRPR2L[R] B,H,W 0000----	IRPR3H[R] B,H,W 00-----	IRPR3L[R] B,H,W 00-----	
000128 <sub>H</sub>	IRPR4H[R] B,H,W 00-----	IRPR4L[R] B,H,W 000000--	IRPR5H[R] B,H,W 00-----	IRPR5L[R] B,H,W 00-----	
00012C <sub>H</sub>	IRPR6H[R] B,H,W 000000--	IRPR6L[R] B,H,W 000000--	IRPR7H[R] B,H,W 000000--	IRPR7L[R] B,H,W 000000--	
000130 <sub>H</sub>	IRPR8H[R] B,H,W 000000--	IRPR8L[R] B,H,W 00-----	IRPR9H[R] B,H,W 00-----	IRPR9L[R] B,H,W 00-----	
000134 <sub>H</sub>	IRPR10H[R] B,H,W 00-----	IRPR10L[R] B,H,W 00-----	IRPR11H[R] B,H,W 00-----	IRPR11L[R] B,H,W 000000-	
000138 <sub>H</sub>	IRPR12H[R] B,H,W 0000000-	IRPR12L[R] B,H,W 00000000	IRPR13H[R] B,H,W 00000000	IRPR13L[R] B,H,W 00000000	
00013C <sub>H</sub>	IRPR14H[R] B,H,W 00-----	IRPR14L[R] B,H,W 00-----	IRPR15H[R] B,H,W 00000000	IRPR15L[R] B,H,W 000000--	
000140 <sub>H</sub>	IRPR16H[R] B,H,W 00-----	IRPR16L[R] B,H,W 00-----	IRPR17H[R] B,H,W 00-----	IRPR17L[R] B,H,W 00-----	
000144 <sub>H</sub>	IRPR18H[R] B,H,W 00-----	IRPR18L[R] B,H,W 000000--	-	-	
000148 <sub>H</sub>   0001FC <sub>H</sub>	-	-	-	-	Reserved
000200 <sub>H</sub>	PCN0[R/W] B,H,W 00000000 000000-0		PCSR0[W] H,W XXXXXXXXXX XXXXXXXXXX		PPG0
000204 <sub>H</sub>	PDUT0[W] H,W XXXXXXXXXX XXXXXXXXXX		PTMR0[R] H,W 11111111 11111111		
000208 <sub>H</sub>	PCN1[R/W] B,H,W 00000000 000000-0		PCSR1[W] H,W XXXXXXXXXX XXXXXXXXXX		PPG1
00020C <sub>H</sub>	PDUT1[W] H,W XXXXXXXXXX XXXXXXXXXX		PTMR1[R] H,W 11111111 11111111		
000210 <sub>H</sub>	PCN2[R/W] B,H,W 00000000 000000-0		PCSR2[W] H,W XXXXXXXXXX XXXXXXXXXX		PPG2
000214 <sub>H</sub>	PDUT2[W] H,W XXXXXXXXXX XXXXXXXXXX		PTMR2[R] H,W 11111111 11111111		

# MB91580L Series

Address	Address offset value/Register name				Block
	+0	+1	+2	+3	
000218 <sub>H</sub>	PCN3[R/W] B,H,W 00000000 000000-0		PCSR3[W] H,W XXXXXXXX XXXXXXXX		PPG3
00021C <sub>H</sub>	PDUT3[W] H,W XXXXXXXX XXXXXXXX		PTMR3[R] H,W 11111111 11111111		
000220 <sub>H</sub>	PCN4[R/W] B,H,W 00000000 000000-0		PCSR4[W] H,W XXXXXXXX XXXXXXXX		PPG4
000224 <sub>H</sub>	PDUT4[W] H,W XXXXXXXX XXXXXXXX		PTMR4[R] H,W 11111111 11111111		
000228 <sub>H</sub>	PCN5[R/W] B,H,W 00000000 000000-0		PCSR5[W] H,W XXXXXXXX XXXXXXXX		PPG5
00022C <sub>H</sub>	PDUT5[W] H,W XXXXXXXX XXXXXXXX		PTMR5[R] H,W 11111111 11111111		
000230 <sub>H</sub>	PCN6[R/W] B,H,W 00000000 000000-0		PCSR6[W] H,W XXXXXXXX XXXXXXXX		PPG6
000234 <sub>H</sub>	PDUT6[W] H,W XXXXXXXX XXXXXXXX		PTMR6[R] H,W 11111111 11111111		
000238 <sub>H</sub>	PCN7[R/W] B,H,W 00000000 000000-0		PCSR7[W] H,W XXXXXXXX XXXXXXXX		PPG7
00023C <sub>H</sub>	PDUT7[W] H,W XXXXXXXX XXXXXXXX		PTMR7[R] H,W 11111111 11111111		
000240 <sub>H</sub>	PCN8[R/W] B,H,W 00000000 000000-0		PCSR8[W] H,W XXXXXXXX XXXXXXXX		PPG8
000244 <sub>H</sub>	PDUT8[W] H,W XXXXXXXX XXXXXXXX		PTMR8[R] H,W 11111111 11111111		
000248 <sub>H</sub>	PCN9[R/W] B,H,W 00000000 000000-0		PCSR9[W] H,W XXXXXXXX XXXXXXXX		PPG9
00024C <sub>H</sub>	PDUT9[W] H,W XXXXXXXX XXXXXXXX		PTMR9[R] H,W 11111111 11111111		
000250 <sub>H</sub>	PCN10[R/W] B,H,W 00000000 000000-0		PCSR10[W] H,W XXXXXXXX XXXXXXXX		PPG10
000254 <sub>H</sub>	PDUT10[W] H,W XXXXXXXX XXXXXXXX		PTMR10[R] H,W 11111111 11111111		
000258 <sub>H</sub>	PCN11[R/W] B,H,W 00000000 000000-0		PCSR11[W] H,W XXXXXXXX XXXXXXXX		PPG11
00025C <sub>H</sub>	PDUT11[W] H,W XXXXXXXX XXXXXXXX		PTMR11[R] H,W 11111111 11111111		
000260 <sub>H</sub>	PCN12[R/W] B,H,W 00000000 000000-0		PCSR12[W] H,W XXXXXXXX XXXXXXXX		PPG12
000264 <sub>H</sub>	PDUT12[W] H,W XXXXXXXX XXXXXXXX		PTMR12[R] H,W 11111111 11111111		
000268 <sub>H</sub>	PCN13[R/W] B,H,W 00000000 000000-0		PCSR13[W] H,W XXXXXXXX XXXXXXXX		PPG13
00026C <sub>H</sub>	PDUT13[W] H,W XXXXXXXX XXXXXXXX		PTMR13[R] H,W 11111111 11111111		
000270 <sub>H</sub>	PCN14[R/W] B,H,W 00000000 000000-0		PCSR14[W] H,W XXXXXXXX XXXXXXXX		PPG14
000274 <sub>H</sub>	PDUT14[W] H,W XXXXXXXX XXXXXXXX		PTMR14[R] H,W 11111111 11111111		
000278 <sub>H</sub>	PCN15[R/W] B,H,W 00000000 000000-0		PCSR15[W] H,W XXXXXXXX XXXXXXXX		PPG15
00027C <sub>H</sub>	PDUT15[W] H,W XXXXXXXX XXXXXXXX		PTMR15[R] H,W 11111111 11111111		

# MB91580L Series

Address	Address offset value/Register name				Block
	+0	+1	+2	+3	
000280 <sub>H</sub>	PCN16[R/W] B,H,W 00000000 000000-0		PCSR16[W] H,W XXXXXXXX XXXXXXXX		PPG16
000284 <sub>H</sub>	PDUT16[W] H,W XXXXXXXX XXXXXXXX		PTMR16[R] H,W 11111111 11111111		
000288 <sub>H</sub>	PCN17[R/W] B,H,W 00000000 000000-0		PCSR17[W] H,W XXXXXXXX XXXXXXXX		PPG17
00028C <sub>H</sub>	PDUT17[W] H,W XXXXXXXX XXXXXXXX		PTMR17[R] H,W 11111111 11111111		
000290 <sub>H</sub>	PCN18[R/W] B,H,W 00000000 000000-0		PCSR18[W] H,W XXXXXXXX XXXXXXXX		PPG18
000294 <sub>H</sub>	PDUT18[W] H,W XXXXXXXX XXXXXXXX		PTMR18[R] H,W 11111111 11111111		
000298 <sub>H</sub>	PCN19[R/W] B,H,W 00000000 000000-0		PCSR19[W] H,W XXXXXXXX XXXXXXXX		PPG19
00029C <sub>H</sub>	PDUT19[W] H,W XXXXXXXX XXXXXXXX		PTMR19[R] H,W 11111111 11111111		
0002A0 <sub>H</sub>	PCN20[R/W] B,H,W 00000000 000000-0		PCSR20[W] H,W XXXXXXXX XXXXXXXX		PPG20
0002A4 <sub>H</sub>	PDUT20[W] H,W XXXXXXXX XXXXXXXX		PTMR20[R] H,W 11111111 11111111		
0002A8 <sub>H</sub>	PCN21[R/W] B,H,W 00000000 000000-0		PCSR21[W] H,W XXXXXXXX XXXXXXXX		PPG21
0002AC <sub>H</sub>	PDUT21[W] H,W XXXXXXXX XXXXXXXX		PTMR21[R] H,W 11111111 11111111		
0002B0 <sub>H</sub>	PCN22[R/W] B,H,W 00000000 000000-0		PCSR22[W] H,W XXXXXXXX XXXXXXXX		PPG22
0002B4 <sub>H</sub>	PDUT22[W] H,W XXXXXXXX XXXXXXXX		PTMR22[R] H,W 11111111 11111111		
0002B8 <sub>H</sub>	PCN23[R/W] B,H,W 00000000 000000-0		PCSR23[W] H,W XXXXXXXX XXXXXXXX		PPG23
0002BC <sub>H</sub>	PDUT23[W] H,W XXXXXXXX XXXXXXXX		PTMR23[R] H,W 11111111 11111111		
0002C0 <sub>H</sub>	GTRS0[R/W] B,H,W -0000000 -0000000		GTRS1[R/W] B,H,W -0000000 -0000000		PPG Control
0002C4 <sub>H</sub>	GTRS2[R/W] B,H,W -0000000 -0000000		GTRS3[R/W] B,H,W -0000000 -0000000		
0002C8 <sub>H</sub>	GTRS4[R/W] B,H,W -0000000 -0000000		GTRS5[R/W] B,H,W -0000000 -0000000		
0002CC <sub>H</sub>	GTRS6[R/W] B,H,W -0000000 -0000000		GTRS7[R/W] B,H,W -0000000 -0000000		
0002D0 <sub>H</sub>	GTRS8[R/W] B,H,W -0000000 -0000000		GTRS9[R/W] B,H,W -0000000 -0000000		
0002D4 <sub>H</sub>	GTRS10[R/W] B,H,W -0000000 -0000000		GTRS11[R/W] B,H,W -0000000 -0000000		
0002D8 <sub>H</sub>	GTREN0[R/W] H,W 00000000 00000000		GTREN1[R/W] H,W ----- 00000000		
0002DC <sub>H</sub>	-		-		Reserved

# MB91580L Series

Address	Address offset value/Register name				Block
	+0	+1	+2	+3	
0002E0 <sub>H</sub>	-	GATEC0[R/W] B,H,W -----00	-	GATEC2[R/W] B,H,W -----00	PPG GATE Control
0002E4 <sub>H</sub>	-	GATEC4[R/W] B,H,W -----00	-	GATEC8[R/W] B,H,W -----00	
0002E8 <sub>H</sub>	-	GATEC10[R/W] B,H,W -----00	-	GATEC12[R/W] B,H,W -----00	
0002EC <sub>H</sub>	-	-	-	-	Reserved
0002F0 <sub>H</sub>	RCRH0[W] H,W 00000000	RCRL0[W] B,H,W 00000000	UDCRH0[R] H,W 00000000	UDCRL0[R] B,H,W 00000000	U/D counter 0
0002F4 <sub>H</sub>	CCR0[R/W] B,H 00000000 -0001000		-	CSR0[R] B 00000000	
0002F8 <sub>H</sub>	RCRH1[W] H,W 00000000	RCRL1[W] B,H,W 00000000	UDCRH1[R] H,W 00000000	UDCRL1[R] B,H,W 00000000	U/D counter 1
0002FC <sub>H</sub>	CCR1[R/W] B,H 00000000 -0001000		-	CSR1[R] B 00000000	
000300 <sub>H</sub>	-				Reserved
000304 <sub>H</sub>	-	-	-	-	Reserved
000308 <sub>H</sub>	-				Reserved
00030C <sub>H</sub>	-	-	-	-	
000310 <sub>H</sub>	-	-	MPUCR[R/W] H 000000-0 ----0100		MPU [S] (Only the CPU can access this area)
000314 <sub>H</sub>	-	-	-	-	
000318 <sub>H</sub>	-				
00031C <sub>H</sub>	-	-	-	-	
000320 <sub>H</sub>	DPVAR[R] W XXXXXXXXXXXXXXXXXXXXXXXXXXXXXXXX				
000324 <sub>H</sub>	-	-	DPVSR[R/W] H ----- 0000--0		
000328 <sub>H</sub>	DEAR[R] W XXXXXXXXXXXXXXXXXXXXXXXXXXXXXXXX				
00032C <sub>H</sub>	-	-	DESR[R/W] H ----- 0000--0		
000330 <sub>H</sub>	PABR0[R/W] W XXXXXXXXXXXXXXXXXXXXXXXXXXXX0000				
000334 <sub>H</sub>	-	-	PACR0[R/W] H 000000-0 0000--0		
000338 <sub>H</sub>	PABR1[R/W] W XXXXXXXXXXXXXXXXXXXXXXXXXXXX0000				
00033C <sub>H</sub>	-	-	PACR1[R/W] H 000000-0 0000--0		
000340 <sub>H</sub>	PABR2[R/W] W XXXXXXXXXXXXXXXXXXXXXXXXXXXX0000				
000344 <sub>H</sub>	-	-	PACR2[R/W] H 000000-0 0000--0		
000348 <sub>H</sub>	PABR3[R/W] W XXXXXXXXXXXXXXXXXXXXXXXXXXXX0000				
00034C <sub>H</sub>	-	-	PACR3[R/W] H 000000-0 0000--0		
000350 <sub>H</sub>	PABR4[R/W] W XXXXXXXXXXXXXXXXXXXXXXXXXXXX0000				



# MB91580L Series

Address	Address offset value/Register name				Block
	+0	+1	+2	+3	
000354 <sub>H</sub>	-	-	PACR4[R/W] H 000000-0 00000--0		MPU [S] (Only the CPU can access this area)
000358 <sub>H</sub>	PABR5[R/W] W XXXXXXXX XXXXXXXX XXXXXXXX XXXX0000				
00035C <sub>H</sub>	-	-	PACR5[R/W] H 000000-0 00000--0		
000360 <sub>H</sub>	PABR6[R/W] W XXXXXXXX XXXXXXXX XXXXXXXX XXXX0000				
000364 <sub>H</sub>	-	-	PACR6[R/W] H 000000-0 00000--0		
000368 <sub>H</sub>	PABR7[R/W] W XXXXXXXX XXXXXXXX XXXXXXXX XXXX0000				
00036C <sub>H</sub>	-	-	PACR7[R/W] H 000000-0 00000--0		
000370 <sub>H</sub>	-				Reserved [S]
000374 <sub>H</sub>	-	-	-		
000378 <sub>H</sub>	-				
00037C <sub>H</sub>	-	-	-		
000380 <sub>H</sub>	-				
000384 <sub>H</sub>	-	-	-		
000388 <sub>H</sub>	-				
00038C <sub>H</sub>	-	-	-		
000390 <sub>H</sub>	-				Reserved [S]
000394 <sub>H</sub>	-	-	-		
000398 <sub>H</sub>	-				
00039C <sub>H</sub>	-	-	-		
0003A0 <sub>H</sub>	-				
0003A4 <sub>H</sub>	-	-	-		
0003A8 <sub>H</sub>	-				Reserved [S]
0003AC <sub>H</sub>	-	-	-		
0003B0 <sub>H</sub>   0003FC <sub>H</sub>	-	-	-	-	Reserved [S]
000400 <sub>H</sub>	ICSEL0[R/W] B,H,W -----000	ICSEL1[R/W] B,H,W -----0	ICSEL2[R/W] B,H,W -----0	ICSEL3[R/W] B,H,W -----0	Generation and clearing of DMA transfer requests
000404 <sub>H</sub>	ICSEL4[R/W] B,H,W -----0	ICSEL5[R/W] B,H,W -----0	ICSEL6[R/W] B,H,W -----0	ICSEL7[R/W] B,H,W ----000	
000408 <sub>H</sub>	ICSEL8[R/W] B,H,W -----0	ICSEL9[R/W] B,H,W -----0	ICSEL10[R/W] B,H,W ----000	ICSEL11[R/W] B,H,W ----000	
00040C <sub>H</sub>	ICSEL12[R/W] B,H,W ----000	ICSEL13[R/W] B,H,W ----000	ICSEL14[R/W] B,H,W ----000	ICSEL15[R/W] B,H,W -----0	
000410 <sub>H</sub>	ICSEL16[R/W] B,H,W -----0	ICSEL17[R/W] B,H,W -----0	ICSEL18[R/W] B,H,W -----0	ICSEL19[R/W] B,H,W -----0	

# MB91580L Series

Address	Address offset value/Register name				Block	
	+0	+1	+2	+3		
000414 <sub>H</sub>	ICSEL20[R/W] B,H,W -----0	ICSEL21[R/W] B,H,W ----000	ICSEL22[R/W] B,H,W ----000	ICSEL23[R/W] B,H,W ----000	Generation and clearing of DMA transfer requests	
000418 <sub>H</sub>	ICSEL24[R/W] B,H,W ----000	ICSEL25[R/W] B,H,W ----000	ICSEL26[R/W] B,H,W -----0	ICSEL27[R/W] B,H,W -----0		
00041C <sub>H</sub>	-	-	-	-		
000420 <sub>H</sub>	-	-	-	-		
000424 <sub>H</sub>   00043C <sub>H</sub>	-	-	-	-	Reserved	
000440 <sub>H</sub>	ICR00[R/W] B,H,W ---1111	ICR01[R/W] B,H,W ---1111	ICR02[R/W] B,H,W ---1111	ICR03[R/W] B,H,W ---1111	Interrupt controller [S]	
000444 <sub>H</sub>	ICR04[R/W] B,H,W ---1111	ICR05[R/W] B,H,W ---1111	ICR06[R/W] B,H,W ---1111	ICR07[R/W] B,H,W ---1111		
000448 <sub>H</sub>	ICR08[R/W] B,H,W ---1111	ICR09[R/W] B,H,W ---1111	ICR10[R/W] B,H,W ---1111	ICR11[R/W] B,H,W ---1111		
00044C <sub>H</sub>	ICR12[R/W] B,H,W ---1111	ICR13[R/W] B,H,W ---1111	ICR14[R/W] B,H,W ---1111	ICR15[R/W] B,H,W ---1111		
000450 <sub>H</sub>	ICR16[R/W] B,H,W ---1111	ICR17[R/W] B,H,W ---1111	ICR18[R/W] B,H,W ---1111	ICR19[R/W] B,H,W ---1111		
000454 <sub>H</sub>	ICR20[R/W] B,H,W ---1111	ICR21[R/W] B,H,W ---1111	ICR22[R/W] B,H,W ---1111	ICR23[R/W] B,H,W ---1111		
000458 <sub>H</sub>	ICR24[R/W] B,H,W ---1111	ICR25[R/W] B,H,W ---1111	ICR26[R/W] B,H,W ---1111	ICR27[R/W] B,H,W ---1111		
00045C <sub>H</sub>	ICR28[R/W] B,H,W ---1111	ICR29[R/W] B,H,W ---1111	ICR30[R/W] B,H,W ---1111	ICR31[R/W] B,H,W ---1111		
000460 <sub>H</sub>	ICR32[R/W] B,H,W ---1111	ICR33[R/W] B,H,W ---1111	ICR34[R/W] B,H,W ---1111	ICR35[R/W] B,H,W ---1111		
000464 <sub>H</sub>	ICR36[R/W] B,H,W ---1111	ICR37[R/W] B,H,W ---1111	ICR38[R/W] B,H,W ---1111	ICR39[R/W] B,H,W ---1111		
000468 <sub>H</sub>	ICR40[R/W] B,H,W ---1111	ICR41[R/W] B,H,W ---1111	ICR42[R/W] B,H,W ---1111	ICR43[R/W] B,H,W ---1111		
00046C <sub>H</sub>	ICR44[R/W] B,H,W ---1111	ICR45[R/W] B,H,W ---1111	ICR46[R/W] B,H,W ---1111	ICR47[R/W] B,H,W ---1111		
000470 <sub>H</sub>   00047C <sub>H</sub>	-	-	-	-		Reserved [S]

# MB91580L Series

Address	Address offset value/Register name				Block
	+0	+1	+2	+3	
000480 <sub>H</sub>	RSTRR[R] B,H,W XXXX--XX	RSTCR[R/W] B,H,W 111----0	STBCR[R/W] B,H,W* 000---11	-	Reset control [S] Power consumption control [S] * Writing to STBCR by DMA is disabled.
000484 <sub>H</sub>	-	-	-	-	Reserved [S]
000488 <sub>H</sub>	DIVR0[R/W] B,H,W 000-----	DIVR1[R/W] B,H,W 0001----	DIVR2[R/W] B,H,W 0011----	-	Clock control [S]
00048C <sub>H</sub>	-	-	-	-	Reserved [S]
000490 <sub>H</sub>	IORR0[R/W] B,H,W -0000000	IORR1[R/W] B,H,W -0000000	IORR2[R/W] B,H,W -0000000	IORR3[R/W] B,H,W -0000000	DMA transfer request from a peripheral [S]
000494 <sub>H</sub>	IORR4[R/W] B,H,W -0000000	IORR5[R/W] B,H,W -0000000	IORR6[R/W] B,H,W -0000000	IORR7[R/W] B,H,W -0000000	
000498 <sub>H</sub>	-	-	-	-	
00049C <sub>H</sub>	-	-	-	-	
0004A0 <sub>H</sub>	-	-	-	-	Reserved
0004A4 <sub>H</sub>	CANPRE[R/W] B,H,W ----0000	-	-	-	CAN prescaler
0004A8 <sub>H</sub>   0004AC <sub>H</sub>	-	-	-	-	Reserved
0004B0 <sub>H</sub>	-	-	-	-	Reserved
0004B4 <sub>H</sub>   0004C0 <sub>H</sub>	-	-	-	-	Reserved
0004C4 <sub>H</sub>	CUCR1[R/W] B,H,W -----0-00		CUTD1[R/W] B,H,W 11000011 01010000		WDT1 calibration
0004C8 <sub>H</sub>	CUTR1[R] B,H,W ----- 00000000 00000000 00000000				
0004CC <sub>H</sub>   0004DC <sub>H</sub>	-	-	-	-	Reserved
0004E0 <sub>H</sub>	-	-	CSCFG[R/W] B,H,W ---0----	CMCFG[R/W] B,H,W 00000000	Clock monitor
0004E4 <sub>H</sub>	-	-	-	-	
0004E8 <sub>H</sub>	PLL2DIVM[R/W] B,H,W ----0000	PLL2DIVN[R/W] B,H,W -0000000	PLL2DIVG[R/W] B,H,W ----0000	PLL2MULG[R/W] B,H,W 00000000	FlexRay clock control
0004EC <sub>H</sub>	PLL2CTRL[R/W] B,H,W ----0000	PLL2DIVK[R/W] B,H,W -----0	CLKR2[R/W] B,H,W 000--000	-	
0004F0 <sub>H</sub>   0004FC <sub>H</sub>	-	-	-	-	Reserved
000500 <sub>H</sub>	-				Reserved
000504 <sub>H</sub>	-				Reserved

# MB91580L Series

Address	Address offset value/Register name				Block	
	+0	+1	+2	+3		
000508 <sub>H</sub>   00050C <sub>H</sub>	-	-	-	-	Reserved	
000510 <sub>H</sub>	CSELR[R/W] B,H,W -0----00	CMONR[R] B,H,W -01---00	MTMCR[R/W] B,H,W 00001111	-	Clock control [S]	
000514 <sub>H</sub>	PLLCR[R/W] B,H,W 00-00000 11110000		CSTBR[R/W] B,H,W ----0000	PTMCR[R/W] B,H,W 00-----		
000518 <sub>H</sub>	-	-	CPUAR[R/W] B,H,W 0---XXXX	-	Reset [S]	
00051C <sub>H</sub>	-	-	-	-	Reserved [S]	
000520 <sub>H</sub>	CCPSEL[R/W] B,H,W -----0	-	-	CCPSDIVR[R/W] B,H,W -000-000	Clock control 2	
000524 <sub>H</sub>	-	CCPLLFB[R/W] B,H,W -0000000	CCSSFBR0[R/W] B,H,W --000000	CCSSFBR1[R/W] B,H,W ---00000		
000528 <sub>H</sub>	-	CCSSCCR0[R/W] B,H,W ----0000	CCSSCCR1[R/W] H,W 000-----			
00052C <sub>H</sub>	-	CCCGRCR0[R/W] B,H,W 00----00	CCCGRCR1[R/W] B,H,W 00000000	CCCGRCR2[R/W] B,H,W 00000000		
000530 <sub>H</sub>	-	-	CCPMUCR0[R/W] B,H,W 0----00	CCPMUCR1[R/W] B,H,W 0--00000		
000534 <sub>H</sub>	-	-	-	-		
000538 <sub>H</sub>	-	-	-	-		
00053C <sub>H</sub>	-	-	-	-		
000540 <sub>H</sub>   00054C <sub>H</sub>	-	-	-	-		Reserved
000550 <sub>H</sub>	EIRRO[R/W] B,H,W XXXXXXXXXX	ENIRO[R/W] B,H,W 00000000	ELVRO[R/W] B,H,W 00000000 00000000			External interrupt (INT0 to 7)
000554 <sub>H</sub>   000568 <sub>H</sub>	-	-	-	-	Reserved	
00056C <sub>H</sub>	-	CSVCR[R/W] B -0--1--0	-	-	CSV	
000570 <sub>H</sub>	CRTR[R/W] B,H,W 01111111	-	-	-	WDT1 calibration (trimming)	
000574 <sub>H</sub>   00057C <sub>H</sub>	-	-	-	-	Reserved	
000580 <sub>H</sub>	REGSEL[R/W] B,H,W 01--110-	-	-	-	Regulator control	
000584 <sub>H</sub>	LVD5R[R/W] B,H,W -----1	LVD5F[R/W] B,H,W 0-010--1	LVD[R/W] B,H,W 01000--0	-	Low-voltage detection	

# MB91580L Series

Address	Address offset value/Register name				Block
	+0	+1	+2	+3	
000588 <sub>H</sub>   00058C <sub>H</sub>	-	-	-	-	Reserved
000590 <sub>H</sub>	PMUSTR [R/W] B,H,W 0-----1X	PMUCTLR[R/W] B,H,W 0-00----	PWRTMCTL[R/W] B,H,W -----011	-	PMU
000594 <sub>H</sub>	-	PMUINTF1[R/W] B,H,W 00000000	PMUINTF2[R/W] B,H,W -00----	-	
000598 <sub>H</sub>	-	-	-	-	
00059C <sub>H</sub>	-	-	-	-	
0005A0 <sub>H</sub>   0005FC <sub>H</sub>	-	-	-	-	Reserved
000600 <sub>H</sub>	ASR0[R/W] W 00000000 00000000 ----- 1111-001				External bus interface [S]
000604 <sub>H</sub>	ASR1[R/W] W XXXXXXXX XXXXXXXX ----- XXXX-XX0				
000608 <sub>H</sub>	ASR2[R/W] W XXXXXXXX XXXXXXXX ----- XXXX-XX0				
00060C <sub>H</sub>	ASR3[R/W] W XXXXXXXX XXXXXXXX ----- XXXX-XX0				
000610 <sub>H</sub>   00063C <sub>H</sub>	-	-	-	-	Reserved[S]
000640 <sub>H</sub>	ACR0[R/W] W ----- 00--00--				External bus interface [S]
000644 <sub>H</sub>	ACR1[R/W] W ----- XX--XX--				
000648 <sub>H</sub>	ACR2[R/W] W ----- XX--XX--				
00064C <sub>H</sub>	ACR3[R/W] W ----- XX--XX--				
000650 <sub>H</sub>   00067C <sub>H</sub>	-	-	-	-	Reserved[S]
000680 <sub>H</sub>	AWR0[R/W] W ----1111 00000000 11110000 00000-0-				External bus interface [S]
000684 <sub>H</sub>	AWR1[R/W] W ----XXXX XXXXXXXX XXXXXXXX XXXXX-X-				
000688 <sub>H</sub>	AWR2[R/W] W ----XXXX XXXXXXXX XXXXXXXX XXXXX-X-				
00068C <sub>H</sub>	AWR3[R/W] W ----XXXX XXXXXXXX XXXXXXXX XXXXX-X-				
000690 <sub>H</sub>   0006BC <sub>H</sub>	-	-	-	-	Reserved[S]
0006C0 <sub>H</sub>	DMAR0[R/W] W -----0000				External bus interface [S]
0006C4 <sub>H</sub>	DMAR1[R/W] W -----0000				
0006C8 <sub>H</sub>	DMAR2[R/W] W -----0000				
0006CC <sub>H</sub>	DMAR3[R/W] W -----0000				

# MB91580L Series

Address	Address offset value/Register name				Block
	+0	+1	+2	+3	
0006D0 <sub>H</sub>   0006F0 <sub>H</sub>	-	-	-	-	Reserved
0006F4 <sub>H</sub>	-				Reserved
0006F8 <sub>H</sub>   0006FC <sub>H</sub>	-	-	-	-	Reserved
000700 <sub>H</sub>	-				Reserved
000704 <sub>H</sub>   00070C <sub>H</sub>	-	-	-	-	Reserved
000710 <sub>H</sub>	BPC CRA[R/W] B 00000000	BPC CRB[R/W] B 00000000	BPC CRC[R/W] B 00000000	-	Bus performance counter
000714 <sub>H</sub>	BPCTRA[R/W] W 00000000 00000000 00000000 00000000				
000718 <sub>H</sub>	BPCTRB[R/W] W 00000000 00000000 00000000 00000000				
00071C <sub>H</sub>	BPCTRC[R/W] W 00000000 00000000 00000000 00000000				
000720 <sub>H</sub>   0007F8 <sub>H</sub>	-	-	-	-	Reserved
0007FC <sub>H</sub>	BMODR[R] B,H,W XXXXXXXX	-	-	-	Operation mode
000800 <sub>H</sub>   00083C <sub>H</sub>	-	-	-	-	Reserved [S]
000840 <sub>H</sub>	FCTL R[R/W] H -0--1000 0--0----		-	FSTR[R/W] B ----001	Flash memory register [S]
000844 <sub>H</sub>	-	-	-	-	Reserved [S]
000848 <sub>H</sub>   000854 <sub>H</sub>	-	-	-	-	Reserved [S]
000858 <sub>H</sub>	-	-	WREN[R/W] H 00000000 00000000		Wild register [S]
00085C <sub>H</sub>   00087C <sub>H</sub>	-	-	-	-	Reserved [S]
000880 <sub>H</sub>	WRAR00[R/W] W ----- --XXXXXX XXXXXXXXXXX XXXXXXX--				Wild register [S]
000884 <sub>H</sub>	WRDR00[R/W] W XXXXXXXX XXXXXXXXXXX XXXXXXXXXXX XXXXXXXXXXX				
000888 <sub>H</sub>	WRAR01[R/W] W ----- --XXXXXX XXXXXXXXXXX XXXXXXX--				
00088C <sub>H</sub>	WRDR01[R/W] W XXXXXXXX XXXXXXXXXXX XXXXXXXXXXX XXXXXXXXXXX				
000890 <sub>H</sub>	WRAR02[R/W] W ----- --XXXXXX XXXXXXXXXXX XXXXXXX--				
000894 <sub>H</sub>	WRDR02[R/W] W XXXXXXXX XXXXXXXXXXX XXXXXXXXXXX XXXXXXXXXXX				
000898 <sub>H</sub>	WRAR03[R/W] W ----- --XXXXXX XXXXXXXXXXX XXXXXXX--				
00089C <sub>H</sub>	WRDR03[R/W] W XXXXXXXX XXXXXXXXXXX XXXXXXXXXXX XXXXXXXXXXX				

# MB91580L Series

Address	Address offset value/Register name				Block
	+0	+1	+2	+3	
0008A0 <sub>H</sub>	WRAR04[R/W] W ----- --XXXXXX XXXXXXXX XXXXXXX--				Wild register [S]
0008A4 <sub>H</sub>	WRDR04[R/W] W XXXXXXXXXXXXXXXXXXXXXXXXXXXXXXXX				
0008A8 <sub>H</sub>	WRAR05[R/W] W ----- --XXXXXX XXXXXXXX XXXXXXX--				
0008AC <sub>H</sub>	WRDR05[R/W] W XXXXXXXXXXXXXXXXXXXXXXXXXXXXXXXX				
0008B0 <sub>H</sub>	WRAR06[R/W] W ----- --XXXXXX XXXXXXXX XXXXXXX--				
0008B4 <sub>H</sub>	WRDR06[R/W] W XXXXXXXXXXXXXXXXXXXXXXXXXXXXXXXX				
0008B8 <sub>H</sub>	WRAR07[R/W] W ----- --XXXXXX XXXXXXXX XXXXXXX--				
0008BC <sub>H</sub>	WRDR07[R/W] W XXXXXXXXXXXXXXXXXXXXXXXXXXXXXXXX				
0008C0 <sub>H</sub>	WRAR08[R/W] W ----- --XXXXXX XXXXXXXX XXXXXXX--				
0008C4 <sub>H</sub>	WRDR08[R/W] W XXXXXXXXXXXXXXXXXXXXXXXXXXXXXXXX				
0008C8 <sub>H</sub>	WRAR09[R/W] W ----- --XXXXXX XXXXXXXX XXXXXXX--				
0008CC <sub>H</sub>	WRDR09[R/W] W XXXXXXXXXXXXXXXXXXXXXXXXXXXXXXXX				
0008D0 <sub>H</sub>	WRAR10[R/W] W ----- --XXXXXX XXXXXXXX XXXXXXX--				
0008D4 <sub>H</sub>	WRDR10[R/W] W XXXXXXXXXXXXXXXXXXXXXXXXXXXXXXXX				
0008D8 <sub>H</sub>	WRAR11[R/W] W ----- --XXXXXX XXXXXXXX XXXXXXX--				
0008DC <sub>H</sub>	WRDR11[R/W] W XXXXXXXXXXXXXXXXXXXXXXXXXXXXXXXX				
0008E0 <sub>H</sub>	WRAR12[R/W] W ----- --XXXXXX XXXXXXXX XXXXXXX--				
0008E4 <sub>H</sub>	WRDR12[R/W] W XXXXXXXXXXXXXXXXXXXXXXXXXXXXXXXX				
0008E8 <sub>H</sub>	WRAR13[R/W] W ----- --XXXXXX XXXXXXXX XXXXXXX--				
0008EC <sub>H</sub>	WRDR13[R/W] W XXXXXXXXXXXXXXXXXXXXXXXXXXXXXXXX				
0008F0 <sub>H</sub>	WRAR14[R/W] W ----- --XXXXXX XXXXXXXX XXXXXXX--				
0008F4 <sub>H</sub>	WRDR14[R/W] W XXXXXXXXXXXXXXXXXXXXXXXXXXXXXXXX				
0008F8 <sub>H</sub>	WRAR15[R/W] W ----- --XXXXXX XXXXXXXX XXXXXXX--				
0008FC <sub>H</sub>	WRDR15[R/W] W XXXXXXXXXXXXXXXXXXXXXXXXXXXXXXXX				
000900 <sub>H</sub>   000BF8 <sub>H</sub>	-	-	-	-	Reserved
000BFC <sub>H</sub>	-	-	UER[W] B,H,W -----X		OCDU

# MB91580L Series

Address	Address offset value/Register name				Block
	+0	+1	+2	+3	
000C00 <sub>H</sub>	DCCR0[R/W] W 0----000 --00--00 00000000 0-000000				DMA controller [S]
000C04 <sub>H</sub>	DCSR0[R/W] H 0-----000		DTCR0[R/W] H 00000000 00000000		
000C08 <sub>H</sub>	DSAR0[R/W] W XXXXXXXXXXXXXXXXXXXXXXXXXXXXXXXX				
000C0C <sub>H</sub>	DDAR0[R/W] W XXXXXXXXXXXXXXXXXXXXXXXXXXXXXXXX				
000C10 <sub>H</sub>	DCCR1[R/W] W 0----000 --00--00 00000000 0-000000				
000C14 <sub>H</sub>	DCSR1[R/W] H 0-----000		DTCR1[R/W] H 00000000 00000000		
000C18 <sub>H</sub>	DSAR1[R/W] W XXXXXXXXXXXXXXXXXXXXXXXXXXXXXXXX				
000C1C <sub>H</sub>	DDAR1[R/W] W XXXXXXXXXXXXXXXXXXXXXXXXXXXXXXXX				
000C20 <sub>H</sub>	DCCR2[R/W] W 0----000 --00--00 00000000 0-000000				
000C24 <sub>H</sub>	DCSR2[R/W] H 0-----000		DTCR2[R/W] H 00000000 00000000		
000C28 <sub>H</sub>	DSAR2[R/W] W XXXXXXXXXXXXXXXXXXXXXXXXXXXXXXXX				
000C2C <sub>H</sub>	DDAR2[R/W] W XXXXXXXXXXXXXXXXXXXXXXXXXXXXXXXX				
000C30 <sub>H</sub>	DCCR3[R/W] W 0----000 --00--00 00000000 0-000000				
000C34 <sub>H</sub>	DCSR3[R/W] H 0-----000		DTCR3[R/W] H 00000000 00000000		
000C38 <sub>H</sub>	DSAR3[R/W] W XXXXXXXXXXXXXXXXXXXXXXXXXXXXXXXX				
000C3C <sub>H</sub>	DDAR3[R/W] W XXXXXXXXXXXXXXXXXXXXXXXXXXXXXXXX				
000C40 <sub>H</sub>	DCCR4[R/W] W 0----000 --00--00 00000000 0-000000				
000C44 <sub>H</sub>	DCSR4[R/W] H 0-----000		DTCR4[R/W] H 00000000 00000000		
000C48 <sub>H</sub>	DSAR4[R/W] W XXXXXXXXXXXXXXXXXXXXXXXXXXXXXXXX				
000C4C <sub>H</sub>	DDAR4[R/W] W XXXXXXXXXXXXXXXXXXXXXXXXXXXXXXXX				
000C50 <sub>H</sub>	DCCR5[R/W] W 0----000 --00--00 00000000 0-000000				
000C54 <sub>H</sub>	DCSR5[R/W] H 0-----000		DTCR5[R/W] H 00000000 00000000		
000C58 <sub>H</sub>	DSAR5[R/W] W XXXXXXXXXXXXXXXXXXXXXXXXXXXXXXXX				
000C5C <sub>H</sub>	DDAR5[R/W] W XXXXXXXXXXXXXXXXXXXXXXXXXXXXXXXX				
000C60 <sub>H</sub>	DCCR6[R/W] W 0----000 --00--00 00000000 0-000000				
000C64 <sub>H</sub>	DCSR6[R/W] H 0-----000		DTCR6[R/W] H 00000000 00000000		
000C68 <sub>H</sub>	DSAR6[R/W] W XXXXXXXXXXXXXXXXXXXXXXXXXXXXXXXX				



# MB91580L Series

Address	Address offset value/Register name				Block
	+0	+1	+2	+3	
000C6C <sub>H</sub>	DDAR6[R/W] W XXXXXXXXXXXXXXXXXXXX				DMA controller [S]
000C70 <sub>H</sub>	DCCR7[R/W] W 0----000 --00--00 00000000 0-000000				
000C74 <sub>H</sub>	DCSR7[R/W] H 0----- ----000		DTCR7[R/W] H 00000000 00000000		
000C78 <sub>H</sub>	DSAR7[R/W] W XXXXXXXXXXXXXXXXXXXX				
000C7C <sub>H</sub>	DDAR7[R/W] W XXXXXXXXXXXXXXXXXXXX				
000C80 <sub>H</sub>   000DF0 <sub>H</sub>	-	-	-	-	
000DF4 <sub>H</sub>	-	-	DNMIR[R/W] B 0-----0	DILVR[R/W] B ---1111	
000DF8 <sub>H</sub>	DMACR[R/W] W 0-----0-----				
000DFC <sub>H</sub>	-	-	-	-	Reserved [S]
000E00 <sub>H</sub>	DDR00[R/W] B,H 00000000	DDR01[R/W] B,H 00000000	DDR02[R/W] B,H 00000000	DDR03[R/W] B,H 00000000	Data direction register
000E04 <sub>H</sub>	DDR04[R/W] B,H 00000000	DDR05[R/W] B,H 00000000	DDR06[R/W] B,H 00000000	DDR07[R/W] B,H 00000000	
000E08 <sub>H</sub>	DDR08[R/W] B,H 00000000	DDR09[R/W] B,H 00000000	DDR10[R/W] B,H 00000000	DDR11[R/W] B,H 00000000	
000E0C <sub>H</sub>	DDR12[R/W] B,H 00000000	DDR13[R/W] B,H 00-00000	-	-	
000E10 <sub>H</sub>   000E1C <sub>H</sub>	-	-	-	-	Reserved
000E20 <sub>H</sub>	PFR00[R/W] B,H 00000000	PFR01[R/W] B,H 00000000	PFR02[R/W] B,H 00000000	PFR03[R/W] B,H 00000000	Port function register
000E24 <sub>H</sub>	PFR04[R/W] B,H 00000000	PFR05[R/W] B,H 00000000	PFR06[R/W] B,H 00000000	PFR07[R/W] B,H 00000000	
000E28 <sub>H</sub>	PFR08[R/W] B,H 00000000	PFR09[R/W] B,H 00000000	PFR10[R/W] B,H 00000000	PFR11[R/W] B,H 00000000	
000E2C <sub>H</sub>	PFR12[R/W] B,H 00000000	PFR13[R/W] B,H 00-00000	-	-	
000E30 <sub>H</sub>   000E3C <sub>H</sub>	-	-	-	-	Reserved
000E40 <sub>H</sub>	PDDR00[R] B,H,W XXXXXXXXXX	PDDR01[R] B,H,W XXXXXXXXXX	PDDR02[R] B,H,W XXXXXXXXXX	PDDR03[R] B,H,W XXXXXXXXXX	Input data direct read register
000E44 <sub>H</sub>	PDDR04[R] B,H,W XXXXXXXXXX	PDDR05[R] B,H,W XXXXXXXXXX	PDDR06[R] B,H,W XXXXXXXXXX	PDDR07[R] B,H,W XXXXXXXXXX	
000E48 <sub>H</sub>	PDDR08[R] B,H,W XXXXXXXXXX	PDDR09[R] B,H,W XXXXXXXXXX	PDDR10[R] B,H,W XXXXXXXXXX	PDDR11[R] B,H,W XXXXXXXXXX	
000E4C <sub>H</sub>	PDDR12[R] B,H,W XXXXXXXXXX	PDDR13[R] B,H,W XX-XXXXX	-	-	
000E50 <sub>H</sub>   000E5C <sub>H</sub>	-	-	-	-	Reserved

# MB91580L Series

Address	Address offset value/Register name				Block
	+0	+1	+2	+3	
000E60 <sub>H</sub>	EPFR00[R/W] B,H ----000	EPFR01[R/W] B,H -----00	EPFR02[R/W] B,H --000000	EPFR03[R/W] B,H 00000000	Extended port function register
000E64 <sub>H</sub>	EPFR04[R/W] B,H 00000000	EPFR05[R/W] B,H 00000000	EPFR06[R/W] B,H -----00	EPFR07[R/W] B,H ----0000	
000E68 <sub>H</sub>	EPFR08[R/W] B,H ----0000	EPFR09[R/W] B,H -----0	EPFR10[R/W] B,H 00000000	EPFR11[R/W] B,H ----0000	
000E6C <sub>H</sub>	-	EPFR13[R/W] B,H -----1	EPFR14[R/W] B,H -0000000	EPFR15[R/W] B,H -0000000	
000E70 <sub>H</sub>	EPFR16[R/W] B,H --000000	EPFR17[R/W] B,H 00000000	EPFR18[R/W] B,H 00000000	EPFR19[R/W] B,H 00000000	
000E74 <sub>H</sub>	EPFR20[R/W] B,H 00000000	EPFR21[R/W] B,H 00000000	EPFR22[R/W] B,H 00000000	EPFR23[R/W] B,H 00000000	
000E78 <sub>H</sub>	EPFR24[R/W] B,H 00000000	EPFR25[R/W] B,H 00000000	EPFR26[R/W] B,H 00000000	EPFR27[R/W] B,H 00000000	
000E7C <sub>H</sub>	EPFR28[R/W] B,H 00000000	EPFR29[R/W] B,H 00000000	EPFR30[R/W] B,H 00000000	EPFR31[R/W] B,H 00000000	
000E80 <sub>H</sub>	EPFR32[R/W] B,H 00000000	-	-	-	
000E84 <sub>H</sub>   000EBC <sub>H</sub>	-	-	-	-	Reserved
000EC0 <sub>H</sub>	PPER00[R/W] B,H 00000000	PPER01[R/W] B,H 00000000	PPER02[R/W] B,H 00000000	PPER03[R/W] B,H 00000000	Port pull-up/down enable register
000EC4 <sub>H</sub>	PPER04[R/W] B,H 00000000	PPER05[R/W] B,H 00000000	PPER06[R/W] B,H 00000000	PPER07[R/W] B,H 00000000	
000EC8 <sub>H</sub>	PPER08[R/W] B,H 00000000	PPER09[R/W] B,H 00000000	PPER10[R/W] B,H 00000000	PPER11[R/W] B,H 00000000	
000ECC <sub>H</sub>	PPER12[R/W] B,H 00000000	PPER13[R/W] B,H 00-00000	-	-	
000ED0 <sub>H</sub>   000EDC <sub>H</sub>	-	-	-	-	Reserved
000EE0 <sub>H</sub>	PILR00[R/W] B,H 11111111	PILR01[R/W] B,H 11111111	PILR02[R/W] B,H 11111111	PILR03[R/W] B,H 11111111	Port input level selection register
000EE4 <sub>H</sub>	PILR04[R/W] B,H 11111111	PILR05[R/W] B,H 11111111	PILR06[R/W] B,H 11111111	PILR07[R/W] B,H 11111111	
000EE8 <sub>H</sub>	PILR08[R/W] B,H 11111111	PILR09[R/W] B,H 11111111	PILR10[R/W] B,H 11111111	PILR11[R/W] B,H 11111111	
000EEC <sub>H</sub>	PILR12[R/W] B,H 11111111	PILR13[R/W] B,H 11-11111	-	-	
000EF0 <sub>H</sub>   000EFC <sub>H</sub>	-	-	-	-	Reserved
000F00 <sub>H</sub>   000F1C <sub>H</sub>	-	-	-	-	Reserved

# MB91580L Series

Address	Address offset value/Register name				Block
	+0	+1	+2	+3	
000F20 <sub>H</sub>	PODR00[R/W] B,H 00000000	PODR01[R/W] B,H 00000000	PODR02[R/W] B,H 00000000	PODR03[R/W] B,H 00000000	Port output drive register
000F24 <sub>H</sub>	PODR04[R/W] B,H 00000000	PODR05[R/W] B,H 00000000	PODR06[R/W] B,H 00000000	PODR07[R/W] B,H 00000000	
000F28 <sub>H</sub>	PODR08[R/W] B,H 00000000	PODR09[R/W] B,H 00000000	PODR10[R/W] B,H 00000000	PODR11[R/W] B,H 00000000	
000F2C <sub>H</sub>	PODR12[R/W] B,H 00000000	PODR13[R/W] B,H 00-00000	-	-	
000F30 <sub>H</sub>   000F3C <sub>H</sub>	-	-	-	-	Reserved
000F40 <sub>H</sub>	PORTEN[R/W] B,H,W -----00	-	-	-	Port input enable register
000F44 <sub>H</sub>	KEYCDR[R/W] H 00000000 00000000		-	-	Port key code
000F48 <sub>H</sub>	ADERH[R/W] B,H ----- 11111111		ADERL[R/W] B,H 11111111 11111111		Analog input enable register
000F4C <sub>H</sub>	DAER[R/W] B,H -----0	-	-	-	Analog output enable register
000F50 <sub>H</sub>   000FFC <sub>H</sub>	-	-	-	-	Reserved
001000 <sub>H</sub>	SACR[R/W] B,H,W -----0	PICD[R/W] B,H,W ----0011	-	-	Synchronous/asynchronous switch control
001004 <sub>H</sub>   0010BC <sub>H</sub>	-	-	-	-	Reserved
0010C0 <sub>H</sub>	-	-	-	CRCCR[R/W] B,H,W -0000000	CRC arithmetic operation
0010C4 <sub>H</sub>	CRCINIT[R/W] B,H,W 11111111 11111111 11111111 11111111				
0010C8 <sub>H</sub>	CRCIN[R/W] B,H,W 00000000 00000000 00000000 00000000				
0010CC <sub>H</sub>	CRCR[R] B,H,W 11111111 11111111 11111111 11111111				
0010D0 <sub>H</sub>   0010FC <sub>H</sub>	-	-	-	-	Reserved
001100 <sub>H</sub>	TCGS[R/W] B,H,W -----00	-	-	TCGSE[R/W] B,H,W --000000	Free-run timer simultaneous activation
001104 <sub>H</sub>	CPCLRB0/CPCLR0[R/W] H,W 11111111 11111111		TCDT0[R/W] H,W 00000000 00000000		Free-run timer 0
001108 <sub>H</sub>	TCCS0[R/W] B,H,W 00000000 01000000 ----0000 -----				

# MB91580L Series

Address	Address offset value/Register name				Block
	+0	+1	+2	+3	
00110 <sub>H</sub>	CPCLRB1/CPCLR1[R/W] H,W 11111111 11111111		TCDT1[R/W] H,W 00000000 00000000		Free-run timer 1
001110 <sub>H</sub>	TCCS1[R/W] B,H,W 00000000 01000000 ----0000 -----				
001114 <sub>H</sub>	CPCLRB2/CPCLR2[R/W] H,W 11111111 11111111		TCDT2[R/W] H,W 00000000 00000000		Free-run timer 2
001118 <sub>H</sub>	TCCS2[R/W] B,H,W 00000000 01000000 ----0000 -----				
00111C <sub>H</sub>	CPCLRB3/CPCLR3[R/W] H,W 11111111 11111111		TCDT3[R/W] H,W 00000000 00000000		Free-run timer 3
001120 <sub>H</sub>	TCCS3[R/W] B,H,W 00000000 01000000 ----0000 -----				
001124 <sub>H</sub>	CPCLRB4/CPCLR4[R/W] H,W 11111111 11111111		TCDT4[R/W] H,W 00000000 00000000		Free-run timer 4
001128 <sub>H</sub>	TCCS4[R/W] B,H,W 00000000 01000000 ----0000 -----				
00112C <sub>H</sub>	CPCLRB5/CPCLR5[R/W] H,W 11111111 11111111		TCDT5[R/W] H,W 00000000 00000000		Free-run timer 5
001130 <sub>H</sub>	TCCS5[R/W] B,H,W 00000000 01000000 ----0000 -----				
001134 <sub>H</sub>	FRS0[R/W] B,H,W -----000-000 -000-000 -000-000				Free-run timer selection
001138 <sub>H</sub>	FRS1[R/W] B,H,W -----000-000 -000-000				
00113C <sub>H</sub>	FRS2[R/W] B,H,W -----000-000 -000-000 -000-000				
001140 <sub>H</sub>	FRS3[R/W] B,H,W -----000-000 -000-000				
001144 <sub>H</sub>	FRS4[R/W] B,H,W -000-000 -000-000 -000-000 -000-000				
001148 <sub>H</sub>	FRS5[R/W] B,H,W -000-000 -000-000 -000-000 -000-000				
00114C <sub>H</sub>	FRS6[R/W] B,H,W -000-000 -000-000 -000-000 -000-000				
001150 <sub>H</sub>	-				
001154 <sub>H</sub>	OCCPB0/OCCP0[R/W] H,W 00000000 00000000		OCCPB1/OCCP1[R/W] H,W 00000000 00000000		Output compare 0/1
001158 <sub>H</sub>	OCS01[R/W] B,H,W -110--00 00001100		-	OCCMOD01[R/W] B,H,W -----00	
00115C <sub>H</sub>	OCCPB2/OCCP2[R/W] H,W 00000000 00000000		OCCPB3/OCCP3[R/W] H,W 00000000 00000000		Output compare 2/3
001160 <sub>H</sub>	OCS23[R/W] B,H,W -110--00 00001100		-	OCCMOD23[R/W] B,H,W -----00	
001164 <sub>H</sub>	OCCPB4/OCCP4[R/W] H,W 00000000 00000000		OCCPB5/OCCP5[R/W] H,W 00000000 00000000		Output compare 4/5
001168 <sub>H</sub>	OCS45[R/W] B,H,W -110--00 00001100		-	OCCMOD45[R/W] B,H,W -----00	
00116C <sub>H</sub>	OCCPB6/OCCP6[R/W] H,W 00000000 00000000		OCCPB7/OCCP7[R/W] H,W 00000000 00000000		Output compare 6/7
001170 <sub>H</sub>	OCS67[R/W] B,H,W -110--00 00001100		-	OCCMOD67[R/W] B,H,W -----00	

# MB91580L Series

Address	Address offset value/Register name				Block
	+0	+1	+2	+3	
001174 <sub>H</sub>	OCCPB8/OCCP8[R/W] H,W 00000000 00000000		OCCPB9/OCCP9[R/W] H,W 00000000 00000000		Output compare 8/9
001178 <sub>H</sub>	OCS89[R/W] B,H,W -110--00 00001100		-	OCMOD89[R/W] B,H,W -----00	
00117C <sub>H</sub>	OCCPB10/OCCP10[R/W] H,W 00000000 00000000		OCCPB11/OCCP11[R/W] H,W 00000000 00000000		Output compare 10/11
001180 <sub>H</sub>	OCS1011[R/W] B,H,W -110--00 00001100		-	OCMOD1011 [R/W] B,H,W -----00	
001184 <sub>H</sub>	IPCP0[R] H,W 00000000 00000000		IPCP1[R] H,W 00000000 00000000		Input capture 0/1
001188 <sub>H</sub>	ICS01[R/W] B,H,W -----00 00000000		-	LSYNS[R/W] B,H,W ---00000	
00118C <sub>H</sub>	IPCP2[R] H,W 00000000 00000000		IPCP3[R] H,W 00000000 00000000		Input capture 2/3
001190 <sub>H</sub>	ICS23[R/W] B,H,W -----00 00000000		-	-	
001194 <sub>H</sub>	IPCP4[R] H,W 00000000 00000000		IPCP5[R] H,W 00000000 00000000		Input capture 4/5
001198 <sub>H</sub>	ICS45[R/W] B,H,W -----00 00000000		-	-	
00119C <sub>H</sub>	IPCP6[R] H,W 00000000 00000000		IPCP7[R] H,W 00000000 00000000		Input capture 6/7
0011A0 <sub>H</sub>	ICS67[R/W] B,H,W -----00 00000000		-	-	
0011A4 <sub>H</sub>	DTSR[R/W] B,H,W -----10	-	-	-	DTTI selection
0011A8 <sub>H</sub>	TMRR0[R/W] H,W 00000000 00000001		TMRR1[R/W] H,W 00000000 00000001		Waveform generator 0/1/2
0011AC <sub>H</sub>	TMRR2[R/W] H,W 00000000 00000001		-	-	
0011B0 <sub>H</sub>	DTSCR0[R/W] B,H,W 00000000	DTSCR1[R/W] B,H,W 00000000	DTSCR2[R/W] B,H,W 00000000	-	
0011B4 <sub>H</sub>	-	DTIR0[R/W] B,H,W 000000--	-	DTMNS0[R/W] B,H,W 00--000	
0011B8 <sub>H</sub>	-	SIGCR10[R/W] B,H,W 00000000	-	SIGCR20[R/W] B,H,W 000000-1	
0011BC <sub>H</sub>	PICS0[R/W] B,H,W 000000-- -----				

# MB91580L Series

Address	Address offset value/Register name				Block
	+0	+1	+2	+3	
0011C0 <sub>H</sub>	TMRR3[R/W] H,W 00000000 00000001		TMRR4[R/W] H,W 00000000 00000001		Waveform generator 3/4/5
0011C4 <sub>H</sub>	TMRR5[R/W] H,W 00000000 00000001		-	-	
0011C8 <sub>H</sub>	DTSCR3[R/W] B,H,W 00000000	DTSCR4[R/W] B,H,W 00000000	DTSCR5[R/W] B,H,W 00000000	-	
0011CC <sub>H</sub>	-	DTIR1[R/W] B,H,W 000000--	-	DTMNS1[R/W] B,H,W 00--000	
0011D0 <sub>H</sub>	-	SIGCR11[R/W] B,H,W 00000000	-	SIGCR21[R/W] B,H,W 000000-1	
0011D4 <sub>H</sub>	PICS1[R/W] B,H,W 000000-- -----				
0011D8 <sub>H</sub>	-	-	-	-	12-bit A/D converter
0011DC <sub>H</sub>	ADTSS[R/W] B,H,W -----0	-	-	-	
0011E0 <sub>H</sub>	ADTSE[R/W] B,H,W ----- 00000000 00000000 00000000				
0011E4 <sub>H</sub>	ADCOMP0/ADCOMPB0[R/W] H,W 00000000 00000000		ADCOMP1/ADCOMPB1[R/W] H,W 00000000 00000000		
0011E8 <sub>H</sub>	ADCOMP2/ADCOMPB2[R/W] H,W 00000000 00000000		ADCOMP3/ADCOMPB3[R/W] H,W 00000000 00000000		
0011EC <sub>H</sub>	ADCOMP4/ADCOMPB4[R/W] H,W 00000000 00000000		ADCOMP5/ADCOMPB5[R/W] H,W 00000000 00000000		
0011F0 <sub>H</sub>	ADCOMP6/ADCOMPB6[R/W] H,W 00000000 00000000		ADCOMP7/ADCOMPB7[R/W] H,W 00000000 00000000		
0011F4 <sub>H</sub>	ADCOMP8/ADCOMPB8[R/W] H,W 00000000 00000000		ADCOMP9/ADCOMPB9[R/W] H,W 00000000 00000000		
0011F8 <sub>H</sub>	ADCOMP10/ADCOMPB10[R/W] H,W 00000000 00000000		ADCOMP11/ADCOMPB11[R/W] H,W 00000000 00000000		
0011FC <sub>H</sub>	ADCOMP12/ADCOMPB12[R/W] H,W 00000000 00000000		ADCOMP13/ADCOMPB13[R/W] H,W 00000000 00000000		
001200 <sub>H</sub>	ADCOMP14/ADCOMPB14[R/W] H,W 00000000 00000000		ADCOMP15/ADCOMPB15[R/W] H,W 00000000 00000000		
001204 <sub>H</sub>	ADCOMP16/ADCOMPB16[R/W] H,W 00000000 00000000		ADCOMP17/ADCOMPB17[R/W] H,W 00000000 00000000		
001208 <sub>H</sub>	ADCOMP18/ADCOMPB18[R/W] H,W 00000000 00000000		ADCOMP19/ADCOMPB19[R/W] H,W 00000000 00000000		
00120C <sub>H</sub>	ADCOMP20/ADCOMPB20[R/W] H,W 00000000 00000000		ADCOMP21/ADCOMPB21[R/W] H,W 00000000 00000000		
001210 <sub>H</sub>	ADCOMP22/ADCOMPB22[R/W] H,W 00000000 00000000		ADCOMP23/ADCOMPB23[R/W] H,W 00000000 00000000		
001214 <sub>H</sub>	-	-	-	-	
001218 <sub>H</sub>	-	-	-	-	
00121C <sub>H</sub>	-	-	-	-	
001220 <sub>H</sub>	-	-	-	-	
001224 <sub>H</sub>	ADTCS0[R/W] B,H,W 00000000 0010-000		ADTCS1[R/W] B,H,W 00000000 0010-000		
001228 <sub>H</sub>	ADTCS2[R/W] B,H,W 00000000 0010-000		ADTCS3[R/W] B,H,W 00000000 0010-000		
00122C <sub>H</sub>	ADTCS4[R/W] B,H,W 00000000 0010-000		ADTCS5[R/W] B,H,W 00000000 0010-000		

# MB91580L Series

Address	Address offset value/Register name				Block
	+0	+1	+2	+3	
001230 <sub>H</sub>	ADTCS6[R/W] B,H,W 00000000 0010-000		ADTCS7[R/W] B,H,W 00000000 0010-000		12-bit A/D converter
001234 <sub>H</sub>	ADTCS8[R/W] B,H,W 00000000 0010-000		ADTCS9[R/W] B,H,W 00000000 0010-000		
001238 <sub>H</sub>	ADTCS10[R/W] B,H,W 00000000 0010-000		ADTCS11[R/W] B,H,W 00000000 0010-000		
00123C <sub>H</sub>	ADTCS12[R/W] B,H,W 00000000 0010-000		ADTCS13[R/W] B,H,W 00000000 0010-000		
001240 <sub>H</sub>	ADTCS14[R/W] B,H,W 00000000 0010-000		ADTCS15[R/W] B,H,W 00000000 0010-000		
001244 <sub>H</sub>	ADTCS16[R/W] B,H,W 00000000 00100000		ADTCS17[R/W] B,H,W 00000000 00100000		
001248 <sub>H</sub>	ADTCS18[R/W] B,H,W 00000000 00100000		ADTCS19[R/W] B,H,W 00000000 00100000		
00124C <sub>H</sub>	ADTCS20[R/W] B,H,W 00000000 00100000		ADTCS21[R/W] B,H,W 00000000 00100000		
001250 <sub>H</sub>	ADTCS22[R/W] B,H,W 00000000 00100000		ADTCS23[R/W] B,H,W 00000000 00100000		
001254 <sub>H</sub>	-	-	-	-	
001258 <sub>H</sub>	-	-	-	-	
00125C <sub>H</sub>	-	-	-	-	
001260 <sub>H</sub>	-	-	-	-	
001264 <sub>H</sub>	ADTCD0[R] B,H,W 10--0000 00000000		ADTCD1[R] B,H,W 10--0000 00000000		
001268 <sub>H</sub>	ADTCD2[R] B,H,W 10--0000 00000000		ADTCD3[R] B,H,W 10--0000 00000000		
00126C <sub>H</sub>	ADTCD4[R] B,H,W 10--0000 00000000		ADTCD5[R] B,H,W 10--0000 00000000		
001270 <sub>H</sub>	ADTCD6[R] B,H,W 10--0000 00000000		ADTCD7[R] B,H,W 10--0000 00000000		
001274 <sub>H</sub>	ADTCD8[R] B,H,W 10--0000 00000000		ADTCD9[R] B,H,W 10--0000 00000000		
001278 <sub>H</sub>	ADTCD10[R] B,H,W 10--0000 00000000		ADTCD11[R] B,H,W 10--0000 00000000		
00127C <sub>H</sub>	ADTCD12[R] B,H,W 10--0000 00000000		ADTCD13[R] B,H,W 10--0000 00000000		
001280 <sub>H</sub>	ADTCD14[R] B,H,W 10--0000 00000000		ADTCD15[R] B,H,W 10--0000 00000000		
001284 <sub>H</sub>	ADTCD16[R] B,H,W 10--0000 00000000		ADTCD17[R] B,H,W 10--0000 00000000		
001288 <sub>H</sub>	ADTCD18[R] B,H,W 10--0000 00000000		ADTCD19[R] B,H,W 10--0000 00000000		
00128C <sub>H</sub>	ADTCD20[R] B,H,W 10--0000 00000000		ADTCD21[R] B,H,W 10--0000 00000000		
001290 <sub>H</sub>	ADTCD22[R] B,H,W 10--0000 00000000		ADTCD23[R] B,H,W 10--0000 00000000		
001294 <sub>H</sub>	-	-	-	-	
001298 <sub>H</sub>	-	-	-	-	
00129C <sub>H</sub>	-	-	-	-	
0012A0 <sub>H</sub>	-	-	-	-	
0012A4 <sub>H</sub>	ADCS0[R/W] B,H,W 0-----		ADCH0[R] B,H,W -----000	ADMD0[R/W] B,H,W -----0000	

# MB91580L Series

Address	Address offset value/Register name				Block
	+0	+1	+2	+3	
0012A8 <sub>H</sub>	ADCS1[R/W] B,H,W 0-----		ADCH1[R] B,H,W ----000	ADMD1[R/W] B,H,W ----0000	12-bit A/D converter
0012AC <sub>H</sub>	ADCS2[R/W] B,H,W 0-----		ADCH2[R] B,H,W ----000	ADMD2[R/W] B,H,W ----0000	
0012B0 <sub>H</sub>   0012FC <sub>H</sub>	-	-	-	-	Reserved
001300 <sub>H</sub>	-	-	-	-	Reserved
001304 <sub>H</sub>	-	-	-	-	
001308 <sub>H</sub>	-	-	-	-	
00130C <sub>H</sub>	-	-	-	-	
001310 <sub>H</sub>	-	-	-	-	
001314 <sub>H</sub>	-	-	-	-	
001318 <sub>H</sub>	-	-	-	-	
00131C <sub>H</sub>	-	-	-	-	
001320 <sub>H</sub>	-	-	-	-	
001324 <sub>H</sub>	-	-	-	-	
001328 <sub>H</sub>	-	-	-	-	
00132C <sub>H</sub>	-	-	-	-	
001330 <sub>H</sub>	-	-	-	-	Reserved
001334 <sub>H</sub>   0013FC <sub>H</sub>	-	-	-	-	
001400 <sub>H</sub>	DACR[R/W] B,H,W -----0	-	DADR[R/W] H,W -----XX XXXXXXXX		DAC
001404 <sub>H</sub>   0014FC <sub>H</sub>	-	-	-	-	Reserved



# MB91580L Series

Address	Address offset value/Register name				Block
	+0	+1	+2	+3	
001500 <sub>H</sub>	SCR0/(IBCR0) [R/W] B,H,W 0--00000	SMR0 [R/W] B,H,W 000000-0	SSR0 [R/W] B,H,W 0--00011	ESCR0/(IBSR0) [R/W] B,H,W 00000000	Multi Function Serial I/F 0 *1: Byte access is possible only for access to lower 8 bits. *2: Reserved because I <sup>2</sup> C mode is not set immediately after reset *3: Reserved because CSIO mode is not set immediately after reset *4: Reserved because LIN2.1 mode is not set immediately after reset
001504 <sub>H</sub>	-/(RDR10/(TDR10))[R/W] B,H,W ----- <sup>*3</sup>		RDR00/(TDR00)[R/W] B,H,W -----0 00000000 <sup>*1</sup>		
001508 <sub>H</sub>	SACSR0[R/W] B,H,W 0----000 00000000		STMR0[R] B,H,W 00000000 00000000		
00150C <sub>H</sub>	STMCR0[R/W] B,H,W 00000000 00000000		-/(SCSCR0/SFUR0) [R/W] B,H,W ----- <sup>*3,*4</sup>		
001510 <sub>H</sub>	-/(SCSTR30) [R/W] B,H,W ----- <sup>*3</sup>	-/(SCSTR20) [R/W] B,H,W ----- <sup>*3</sup>	-/(SCSTR10/SFLR 10) [R/W] B,H,W ----- <sup>*3,*4</sup>	-/(SCSTR00/SFLR 00) [R/W] B,H,W ----- <sup>*3,*4</sup>	
001514 <sub>H</sub>	-	-	-	-	
001518 <sub>H</sub>	-	-	-	-	
00151C <sub>H</sub>	BGR0[R/W] H,W 00000000 00000000		-/(ISMK0)[R/W] B,H,W ----- <sup>*2</sup>	-/(ISBA0)[R/W] B,H,W ----- <sup>*2</sup>	
001520 <sub>H</sub>	FCR10[R/W] B,H,W 00-00100	FCR00 [R/W] B,H,W -0000000	FBYTE20 [R/W] B,H,W 00000000	FBYTE10 [R/W] B,H,W 00000000	
001524 <sub>H</sub>	SCR1/(IBCR1) [R/W] B,H,W 0--00000	SMR1[R/W] B,H,W 000000-0	SSR1[R/W] B,H,W 0--00011	ESCR1/(IBSR1) [R/W] B,H,W 00000000	
001528 <sub>H</sub>	-/(RDR11/(TDR11))[R/W] B,H,W ----- <sup>*3</sup>		RDR01/(TDR01)[R/W] B,H,W -----0 00000000 <sup>*1</sup>		
00152C <sub>H</sub>	SACSR1[R/W] B,H,W 0----000 00000000		STMR1[R] B,H,W 00000000 00000000		
001530 <sub>H</sub>	STMCR1[R/W] B,H,W 00000000 00000000		-/(SCSCR1/SFUR1) [R/W] B,H,W ----- <sup>*3,*4</sup>		
001534 <sub>H</sub>	-/(SCSTR31) [R/W] B,H,W ----- <sup>*3</sup>	-/(SCSTR21) [R/W] B,H,W ----- <sup>*3</sup>	-/(SCSTR11/SFLR 1) [R/W] B,H,W ----- <sup>*3,*4</sup>	-/(SCSTR01/SFLR 01) [R/W] B,H,W ----- <sup>*3,*4</sup>	
001538 <sub>H</sub>	-	-	-	-	
00153C <sub>H</sub>	-	-	-	TBYTE01[R/W] B,H,W 00000000	
001540 <sub>H</sub>	BGR1[R/W] H,W 00000000 00000000		-/(ISMK1)[R/W] B,H,W ----- <sup>*2</sup>	-/(ISBA1)[R/W] B,H,W ----- <sup>*2</sup>	
001544 <sub>H</sub>	FCR11[R/W] B,H,W 00-00100	FCR01[R/W] B,H,W -0000000	FBYTE21[R/W] B,H,W 00000000	FBYTE11[R/W] B,H,W 00000000	

# MB91580L Series

Address	Address offset value/Register name				Block
	+0	+1	+2	+3	
001548 <sub>H</sub>	SCR2[R/W] B,H,W 0--00000	SMR2[R/W] B,H,W 000000-0	SSR2[R/W] B,H,W 0--00011	ESCR2[R/W] B,H,W 00000000	Multi Function Serial I/F 2 *1: Byte access is possible only for access to lower 8 bits. *3: Reserved because CSIO mode is not set immediately after reset *4: Reserved because LIN2.1 mode is not set immediately after reset
00154C <sub>H</sub>	-/(RDR12/(TDR12))[R/W] B,H,W ----- <sup>*3</sup>		RDR02/(TDR02)[R/W] B,H,W -----0 00000000 <sup>*1</sup>		
001550 <sub>H</sub>	SACSR2[R/W] B,H,W 0----000 00000000		STMR2[R] B,H,W 00000000 00000000		
001554 <sub>H</sub>	STMCR2[R/W] B,H,W 00000000 00000000		-/(SCSCR2/SFUR2) [R/W] B,H,W ----- <sup>*3,*4</sup>		
001558 <sub>H</sub>	-/(SCSTR32) [R/W] B,H,W ----- <sup>*3</sup>	-/(SCSTR22) [R/W] B,H,W ----- <sup>*3</sup>	-/(SCSTR12/SFLR 12) [R/W] B,H,W ----- <sup>*3,*4</sup>	-/(SCSTR02/SFLR 02) [R/W] B,H,W ----- <sup>*3,*4</sup>	
00155C <sub>H</sub>	-	-	-	-	
001560 <sub>H</sub>	-	-	-	TBYTE02[R/W] B,H,W 00000000	
001564 <sub>H</sub>	BGR2[R/W] H,W 00000000 00000000		-	-	
001568 <sub>H</sub>	FCR12[R/W] B,H,W 00-00100	FCR02[R/W] B,H,W -0000000	FBYTE22[R/W] B,H,W 00000000	FBYTE12[R/W] B,H,W 00000000	
00156C <sub>H</sub>	SCR3/(IBCR3) [R/W] B,H,W 0--00000	SMR3 [R/W] B,H,W 000000-0	SSR3 [R/W] B,H,W 0--00011	ESCR3/(IBSR3) [R/W] B,H,W 00000000	
001570 <sub>H</sub>	-/(RDR13/(TDR13))[R/W] B,H,W ----- <sup>*3</sup>		RDR03/(TDR03)[R/W] B,H,W -----0 00000000 <sup>*1</sup>		
001574 <sub>H</sub>	SACSR3[R/W] B,H,W 0----000 00000000		STMR3[R] B,H,W 00000000 00000000		
001578 <sub>H</sub>	STMCR3[R/W] B,H,W 00000000 00000000		-/(SCSCR3/SFUR3) [R/W] B,H,W ----- <sup>*3,*4</sup>		
00157C <sub>H</sub>	-/(SCSTR33) [R/W] B,H,W ----- <sup>*3</sup>	-/(SCSTR23) [R/W] B,H,W ----- <sup>*3</sup>	-/(SCSTR13/SFLR 13) [R/W] B,H,W ----- <sup>*3,*4</sup>	-/(SCSTR03/SFLR 03) [R/W] B,H,W ----- <sup>*3,*4</sup>	
001580 <sub>H</sub>	-	-	-	-	
001584 <sub>H</sub>	-	-	-	TBYTE03[R/W] B,H,W 00000000	
001588 <sub>H</sub>	BGR3[R/W] H,W 00000000 00000000		-/(ISMK3)[R/W] B,H,W ----- <sup>*2</sup>	-/(ISBA3)[R/W] B,H,W ----- <sup>*2</sup>	
00158C <sub>H</sub>	FCR13[R/W] B,H,W 00-00100	FCR03[R/W] B,H,W -0000000	FBYTE23[R/W] B,H,W 00000000	FBYTE13[R/W] B,H,W 00000000	

# MB91580L Series

Address	Address offset value/Register name				Block
	+0	+1	+2	+3	
001590 <sub>H</sub>	SCR4/(IBCR4) [R/W] B,H,W 0--00000	SMR4 [R/W] B,H,W 000000-0	SSR4 [R/W] B,H,W 0--00011	ESCR4/(IBSR4) [R/W] B,H,W 00000000	Multi Function Serial I/F 4 *1: Byte access is possible only for access to lower 8 bits. *2: Reserved because I <sup>2</sup> C mode is not set immediately after reset *3: Reserved because CSIO mode is not set immediately after reset *4: Reserved because LIN2.1 mode is not set immediately after reset
001594 <sub>H</sub>	-/(RDR14/(TDR14))[R/W] B,H,W ----- *3		RDR04/(TDR04)[R/W] B,H,W -----0 00000000 *1		
001598 <sub>H</sub>	SACSR4[R/W] B,H,W 0----000 00000000		STMR4[R] B,H,W 00000000 00000000		
00159C <sub>H</sub>	STMCR4[R/W] B,H,W 00000000 00000000		-/(SCSCR4/SFUR4) [R/W] B,H,W ----- *3,*4		
0015A0 <sub>H</sub>	-/(SCSTR34) [R/W] B,H,W ----- *3	-/(SCSTR24) [R/W] B,H,W ----- *3	-/(SCSTR14/SFLR 14) [R/W] B,H,W ----- *3,*4	-/(SCSTR04/SFLR 04) [R/W] B,H,W ----- *3,*4	
0015A4 <sub>H</sub>	-	-/(SCSFR24)[R/W] B,H,W ----- *3	-/(SCSFR14)[R/W] B,H,W ----- *3	-/(SCSFR04)[R/W] B,H,W ----- *3	
0015A8 <sub>H</sub>	-/(TBYTE34)[R/W] B,H,W ----- *3	-/(TBYTE24)[R/W] B,H,W ----- *3	-/(TBYTE14)[R/W] B,H,W ----- *3	TBYTE04[R/W] B,H,W 00000000	
0015AC <sub>H</sub>	BGR4[R/W] H,W 00000000 00000000		-/(ISMK4)[R/W] B,H,W ----- *2	-/(ISBA4)[R/W] B,H,W ----- *2	
0015B0 <sub>H</sub>	FCR14[R/W] B,H,W 00-00100	FCR04[R/W] B,H,W -0000000	FBYTE24[R/W] B,H,W 00000000	FBYTE14[R/W] B,H,W 00000000	
0015B4 <sub>H</sub>   001FFC <sub>H</sub>	-	-	-	-	
002000 <sub>H</sub>	CTRLR0[R/W] B,H,W ----- 000-0001		STATR0[R/W] B,H,W ----- 00000000		CAN 0 64msb
002004 <sub>H</sub>	ERRCNT0 [R] B,H,W 00000000 00000000		BTR0[R/W] B,H,W -0100011 00000001		
002008 <sub>H</sub>	INTR0[R] B,H,W 00000000 00000000		TESTR0[R/W] B,H,W ----- X00000--		
00200C <sub>H</sub>	BRPER0[R/W] B,H,W ----- ----0000		-		
002010 <sub>H</sub>	IF1CREQ0[R/W] B,H,W 0----- 00000001		IF1CMSK0[R/W] B,H,W ----- 00000000		
002014 <sub>H</sub>	IF1MSK20[R/W] B,H,W 11-11111 11111111		IF1MSK10[R/W] B,H,W 11111111 11111111		
002018 <sub>H</sub>	IF1ARB20[R/W] B,H,W 00000000 00000000		IF1ARB10[R/W] B,H,W 00000000 00000000		
00201C <sub>H</sub>	IF1MCTR0[R/W] B,H,W 00000000 0---0000		-		
002020 <sub>H</sub>	IF1DTA10[R/W] B,H,W 00000000 00000000		IF1DTA20[R/W] B,H,W 00000000 00000000		
002024 <sub>H</sub>	IF1DTB10[R/W] B,H,W 00000000 00000000		IF1DTB20[R/W] B,H,W 00000000 00000000		
002028 <sub>H</sub> , 00202C <sub>H</sub>	-		-		
002030 <sub>H</sub> , 002034 <sub>H</sub>	Reserved (IF1 data mirror)				
002038 <sub>H</sub> , 00203C <sub>H</sub>	-		-		
002040 <sub>H</sub>	IF2CREQ0[R/W] B,H,W 0----- 00000001		IF2CMSK0[R/W] B,H,W ----- 00000000		

# MB91580L Series

Address	Address offset value/Register name				Block
	+0	+1	+2	+3	
002044 <sub>H</sub>	IF2MSK20[R/W] B,H,W 11-11111 11111111		IF2MSK10[R/W] B,H,W 11111111 11111111		CAN 0 64msb
002048 <sub>H</sub>	IF2ARB20[R/W] B,H,W 00000000 00000000		IF2ARB10[R/W] B,H,W 00000000 00000000		
00204C <sub>H</sub>	IF2MCTR0[R/W] B,H,W 00000000 0---0000		-		
002050 <sub>H</sub>	IF2DTA10[R/W] B,H,W 00000000 00000000		IF2DTA20[R/W] B,H,W 00000000 00000000		
002054 <sub>H</sub>	IF2DTB10[R/W] B,H,W 00000000 00000000		IF2DTB20[R/W] B,H,W 00000000 00000000		
002058 <sub>H</sub> , 00205C <sub>H</sub>	-		-		
002060 <sub>H</sub> , 002064 <sub>H</sub>	Reserved (IF2 data mirror)				
002068 <sub>H</sub>   00207C <sub>H</sub>	-		-		
002080 <sub>H</sub>	TREQR20[R] B,H,W 00000000 00000000		TREQR10[R] B,H,W 00000000 00000000		
002084 <sub>H</sub>	TREQR40[R] B,H,W 00000000 00000000		TREQR30[R] B,H,W 00000000 00000000		
002088 <sub>H</sub>	-		-		
00208C <sub>H</sub>	-		-		
002090 <sub>H</sub>	NEWDT20[R] B,H,W 00000000 00000000		NEWDT10[R] B,H,W 00000000 00000000		
002094 <sub>H</sub>	NEWDT40[R] B,H,W 00000000 00000000		NEWDT30[R] B,H,W 00000000 00000000		
002098 <sub>H</sub>	-		-		
00209C <sub>H</sub>	-		-		
0020A0 <sub>H</sub>	INTPND20[R] B,H,W 00000000 00000000		INTPND10[R] B,H,W 00000000 00000000		
0020A4 <sub>H</sub>	INTPND40[R] B,H,W 00000000 00000000		INTPND30[R] B,H,W 00000000 00000000		
0020A8 <sub>H</sub>	-		-		
0020AC <sub>H</sub>	-		-		
0020B0 <sub>H</sub>	MSGVAL20[R] B,H,W 00000000 00000000		MSGVAL10[R] B,H,W 00000000 00000000		
0020B4 <sub>H</sub>	MSGVAL40[R] B,H,W 00000000 00000000		MSGVAL30[R] B,H,W 00000000 00000000		
0020B8 <sub>H</sub>	-		-		
0020BC <sub>H</sub>	-		-		
0020C0 <sub>H</sub>   0020FC <sub>H</sub>	-		-		
002100 <sub>H</sub>	CTRLR1[R/W] B,H,W ----- 000-0001		STATR1[R/W] B,H,W ----- 00000000		
002104 <sub>H</sub>	ERRCNT1 [R] B,H,W 00000000 00000000		BTR1[R/W] B,H,W -0100011 00000001		
002108 <sub>H</sub>	INTR1[R] B,H,W 00000000 00000000		TESTR1[R/W] B,H,W ----- X00000--		
00210C <sub>H</sub>	BRPER1[R/W] B,H,W ----- ----0000		-		
002110 <sub>H</sub>	IF1CREQ1[R/W] B,H,W 0----- 00000001		IF1CMSK1[R/W] B,H,W ----- 00000000		

# MB91580L Series

Address	Address offset value/Register name				Block
	+0	+1	+2	+3	
002114 <sub>H</sub>	IF1MSK21[R/W] B,H,W 11-11111 11111111		IF1MSK11[R/W] B,H,W 11111111 11111111		CAN 1 64msb
002118 <sub>H</sub>	IF1ARB21[R/W] B,H,W 00000000 00000000		IF1ARB11[R/W] B,H,W 00000000 00000000		
00211C <sub>H</sub>	IF1MCTR1[R/W] B,H,W 00000000 0--0000		-		
002120 <sub>H</sub>	IF1DTA11[R/W] B,H,W 00000000 00000000		IF1DTA21[R/W] B,H,W 00000000 00000000		
002124 <sub>H</sub>	IF1DTB11[R/W] B,H,W 00000000 00000000		IF1DTB21[R/W] B,H,W 00000000 00000000		
002128 <sub>H</sub> , 00212C <sub>H</sub>	-		-		
002130 <sub>H</sub> , 002134 <sub>H</sub>	Reserved (IF1 data mirror)				
002138 <sub>H</sub> , 00213C <sub>H</sub>	-		-		
002140 <sub>H</sub>	IF2CREQ1[R/W] B,H,W 0----- 00000001		IF2CMSK1[R/W] B,H,W ----- 00000000		
002144 <sub>H</sub>	IF2MSK21[R/W] B,H,W 11-11111 11111111		IF2MSK11[R/W] B,H,W 11111111 11111111		
002148 <sub>H</sub>	IF2ARB21[R/W] B,H,W 00000000 00000000		IF2ARB11[R/W] B,H,W 00000000 00000000		
00214C <sub>H</sub>	IF2MCTR1[R/W] B,H,W 00000000 0--0000		-		
002150 <sub>H</sub>	IF2DTA11[R/W] B,H,W 00000000 00000000		IF2DTA21[R/W] B,H,W 00000000 00000000		
002154 <sub>H</sub>	IF2DTB11[R/W] B,H,W 00000000 00000000		IF2DTB21[R/W] B,H,W 00000000 00000000		
002158 <sub>H</sub> , 00215C <sub>H</sub>	-		-		
002160 <sub>H</sub> , 002164 <sub>H</sub>	Reserved (IF2 data mirror)				
002168 <sub>H</sub>   00217C <sub>H</sub>	-		-		
002180 <sub>H</sub>	TREQR21[R] B,H,W 00000000 00000000		TREQR11[R] B,H,W 00000000 00000000		
002184 <sub>H</sub>	TREQR41[R] B,H,W 00000000 00000000		TREQR31[R] B,H,W 00000000 00000000		
002188 <sub>H</sub>	-		-		
00218C <sub>H</sub>	-		-		
002190 <sub>H</sub>	NEWDT21[R] B,H,W 00000000 00000000		NEWDT11[R] B,H,W 00000000 00000000		
002194 <sub>H</sub>	NEWDT41[R] B,H,W 00000000 00000000		NEWDT31[R] B,H,W 00000000 00000000		
002198 <sub>H</sub>	-		-		
00219C <sub>H</sub>	-		-		
0021A0 <sub>H</sub>	INTPND21[R] B,H,W 00000000 00000000		INTPND11[R] B,H,W 00000000 00000000		
0021A4 <sub>H</sub>	INTPND41[R] B,H,W 00000000 00000000		INTPND31[R] B,H,W 00000000 00000000		
0021A8 <sub>H</sub>	-		-		
0021AC <sub>H</sub>	-		-		
0021B0 <sub>H</sub>	MSGVAL21[R] B,H,W 00000000 00000000		MSGVAL11[R] B,H,W 00000000 00000000		

# MB91580L Series

Address	Address offset value/Register name				Block
	+0	+1	+2	+3	
0021B4 <sub>H</sub>	MSGVAL41[R] B,H,W 00000000 00000000		MSGVAL31[R] B,H,W 00000000 00000000		CAN 1 64msb
0021B8 <sub>H</sub>	-		-		
0021BC <sub>H</sub>	-		-		
0021C0 <sub>H</sub>   0021FC <sub>H</sub>	-		-		
002200 <sub>H</sub>	CTRLR2[R/W] B,H,W ----- 000-0001		STATR2[R/W] B,H,W ----- 00000000		
002204 <sub>H</sub>	ERRCNT2 [R] B,H,W 00000000 00000000		BTR2[R/W] B,H,W -0100011 00000001		
002208 <sub>H</sub>	INTR2[R] B,H,W 00000000 00000000		TESTR2[R/W] B,H,W ----- X00000--		
00220C <sub>H</sub>	BRPER2[R/W] B,H,W ----- ----0000		-		
002210 <sub>H</sub>	IF1CREQ2[R/W] B,H,W 0----- 00000001		IF1CMSK2[R/W] B,H,W ----- 00000000		
002214 <sub>H</sub>	IF1MSK22[R/W] B,H,W 11-11111 11111111		IF1MSK12[R/W] B,H,W 11111111 11111111		
002218 <sub>H</sub>	IF1ARB22[R/W] B,H,W 00000000 00000000		IF1ARB12[R/W] B,H,W 00000000 00000000		
00221C <sub>H</sub>	IF1MCTR2[R/W] B,H,W 00000000 0--0000		-		
002220 <sub>H</sub>	IF1DTA12[R/W] B,H,W 00000000 00000000		IF1DTA22[R/W] B,H,W 00000000 00000000		
002224 <sub>H</sub>	IF1DTB12[R/W] B,H,W 00000000 00000000		IF1DTB22[R/W] B,H,W 00000000 00000000		
002228 <sub>H</sub> , 00222C <sub>H</sub>	-		-		
002230 <sub>H</sub> , 002234 <sub>H</sub>	Reserved (IF1 data mirror)				CAN 2 64msb
002238 <sub>H</sub> , 00223C <sub>H</sub>	-		-		
002240 <sub>H</sub>	IF2CREQ2[R/W] B,H,W 0----- 00000001		IF2CMSK2[R/W] B,H,W ----- 00000000		
002244 <sub>H</sub>	IF2MSK22[R/W] B,H,W 11-11111 11111111		IF2MSK12[R/W] B,H,W 11111111 11111111		
002248 <sub>H</sub>	IF2ARB22[R/W] B,H,W 00000000 00000000		IF2ARB12[R/W] B,H,W 00000000 00000000		
00224C <sub>H</sub>	IF2MCTR2[R/W] B,H,W 00000000 0--0000		-		
002250 <sub>H</sub>	IF2DTA12[R/W] B,H,W 00000000 00000000		IF2DTA22[R/W] B,H,W 00000000 00000000		
002254 <sub>H</sub>	IF2DTB12[R/W] B,H,W 00000000 00000000		IF2DTB22[R/W] B,H,W 00000000 00000000		
002258 <sub>H</sub> , 00225C <sub>H</sub>	-		-		
002260 <sub>H</sub> , 002264 <sub>H</sub>	Reserved (IF2 data mirror)				
002268 <sub>H</sub>   00227C <sub>H</sub>	-		-		
002280 <sub>H</sub>	TREQR22[R] B,H,W 00000000 00000000		TREQR12[R] B,H,W 00000000 00000000		

# MB91580L Series

Address	Address offset value/Register name				Block
	+0	+1	+2	+3	
002284 <sub>H</sub>	TREQR42[R] B,H,W 00000000 00000000		TREQR32[R] B,H,W 00000000 00000000		CAN 2 64msb
002288 <sub>H</sub>	-		-		
00228C <sub>H</sub>	-		-		
002290 <sub>H</sub>	NEWDT22[R] B,H,W 00000000 00000000		NEWDT12[R] B,H,W 00000000 00000000		
002294 <sub>H</sub>	NEWDT42[R] B,H,W 00000000 00000000		NEWDT32[R] B,H,W 00000000 00000000		
002298 <sub>H</sub>	-		-		
00229C <sub>H</sub>	-		-		
0022A0 <sub>H</sub>	INTPND22[R] B,H,W 00000000 00000000		INTPND12[R] B,H,W 00000000 00000000		
0022A4 <sub>H</sub>	INTPND42[R] B,H,W 00000000 00000000		INTPND32[R] B,H,W 00000000 00000000		
0022A8 <sub>H</sub>	-		-		
0022AC <sub>H</sub>	-		-		
0022B0 <sub>H</sub>	MSGVAL22[R] B,H,W 00000000 00000000		MSGVAL12[R] B,H,W 00000000 00000000		
0022B4 <sub>H</sub>	MSGVAL42[R] B,H,W 00000000 00000000		MSGVAL32[R] B,H,W 00000000 00000000		
0022B8 <sub>H</sub>	-		-		
0022BC <sub>H</sub>	-		-		
0022C0 <sub>H</sub>   0022FC <sub>H</sub>	-	-	-	-	
002300 <sub>H</sub>	DFCTLR[R/W] B,H,W -0-----		-	DFSTR[R/W] B,H,W -----001	WorkFlash
002304 <sub>H</sub>	-	-	-	-	
002308 <sub>H</sub>	FLIFCTLR[R/W] B,H,W ---0--00	-	FLIFFER1[R/W] B,H,W -----	FLIFFER2[R/W] B,H,W -----	
00230C <sub>H</sub>   0022FC <sub>H</sub>	-	-	-	-	Reserved
003000 <sub>H</sub>	SEEARX[R] B,H,W -0000000 00000000		DEEARX[R] B,H,W -0000000 00000000		XBS RAM ECC control register
003004 <sub>H</sub>	EECSRX[R/W] B,H,W ----00-0	-	EFEARX[R/W] B,H,W -0000000 00000000		
003008 <sub>H</sub>	-	EFECRX[R/W] B,H,W -----0 00000000 00000000			

# MB91580L Series

Address	Address offset value/Register name				Block
	+0	+1	+2	+3	
00300 <sub>H</sub>	TEAR0X[R] B,H,W 000-----0000000 00000000				XBS RAM diagnosis register
003010 <sub>H</sub>	TEAR1X[R] B,H,W 000-----0000000 00000000				
003014 <sub>H</sub>	TEAR2X[R] B,H,W 000-----0000000 00000000				
003018 <sub>H</sub>	TAEARX[R/W] B,H,W -1011111 11111111		TASARX[R/W] B,H,W -0000000 00000000		
00301C <sub>H</sub>	TFECRX[R/W] B,H,W ----0000	TICRX[R/W] B,H,W ----0000	TTCRX[R/W] B,H,W -----00 00001100		
003020 <sub>H</sub>	TSRCRX[R/W] B,H,W 0-----	-	-	TKCCRX[R/W] B,H,W 00----00	
003024 <sub>H</sub>	SEEARA[R] B,H,W --000000 00000000		DEEARA[R] B,H,W --000000 00000000		Backup RAM ECC control register
003028 <sub>H</sub>	EECSRA[R/W] B,H,W ----00-0	-	EFEARA[R/W] B,H,W --000000 00000000		
00302C <sub>H</sub>	-	EFECRA[R/W] B,H,W -----0 00000000 00000000			
003030 <sub>H</sub>	TEAR0A[R] B,H,W 000-----000 00000000				Backup RAM diagnosis register
003034 <sub>H</sub>	TEAR1A[R] B,H,W 000-----000 00000000				
003038 <sub>H</sub>	TEAR2A[R] B,H,W 000-----000 00000000				
00303C <sub>H</sub>	TAEARA[R/W] B,H,W ----111 11111111		TASARA[R/W] B,H,W ----000 00000000		
003040 <sub>H</sub>	TFECRA[R/W] B,H,W ----0000	TICRA[R/W] B,H,W ----0000	TTCRA[R/W] B,H,W -----00 00001100		
003044 <sub>H</sub>	TSRCRA[R/W] B,H,W 0-----	-	-	TKCCRA[R/W] B,H,W 00----00	
003048 <sub>H</sub>   0030FC <sub>H</sub>	-	-	-	-	Reserved
003100 <sub>H</sub>	BUSDIGSR0[R/W] H,W 00000000 0-----00		BUSDIGSR1[R/W] H,W 00000000 0-----00		Bus diagnosis
003104 <sub>H</sub>	BUSDIGSR2[R/W] H,W 00000000 0-----00		BUSTSTR0[R/W] H,W 00--0000 00000000		
003108 <sub>H</sub>	BUSADR0[R] W 00000000 00000000 00000000 00000000				
00310C <sub>H</sub>	BUSADR1[R] W 00000000 00000000 00000000 00000000				
003110 <sub>H</sub>	BUSADR2[R] W 00000000 00000000 00000000 00000000				
003114 <sub>H</sub>	-		BUSDIGSR3[R/W] H,W 00000000 0-----00		
003118 <sub>H</sub>	BUSDIGSR4[R/W] H,W 00000000 0-----00		BUSTSTR1[R/W] H,W 00--0000 00000000		
00311C <sub>H</sub>	-				
003120 <sub>H</sub>	BUSADR3[R] W 00000000 00000000 00000000 00000000				



# MB91580L Series

Address	Address offset value/Register name				Block
	+0	+1	+2	+3	
003124 <sub>H</sub>	BUSADR4[R] W 00000000 00000000 00000000 00000000				Bus diagnosis
003128 <sub>H</sub>   003FFC <sub>H</sub>	-	-	-	-	Reserved
004000 <sub>H</sub>   005FFC <sub>H</sub>	Backup RAM				Backup RAM area
006000 <sub>H</sub>   00CFFC <sub>H</sub>	-	-	-	-	Reserved
00D000 <sub>H</sub>	CIF0[R] W 00000100 11111111 01011011 11111111				FlexRay CIF
00D004 <sub>H</sub>	CIF1[R/W] W 00000000 -----0 -0000000 -----				
00D008 <sub>H</sub>   00D00C <sub>H</sub>	-	-	-	-	Reserved
00D010 <sub>H</sub>	-				FlexRay GIF
00D014 <sub>H</sub>	-				
00D018 <sub>H</sub>	-	-	-	-	
00D01C <sub>H</sub>	LCK[R/W] W -----00000000				
00D020 <sub>H</sub>	EIR[R/W] W ----000 ----000 ----0000 00000000				FlexRay INT
00D024 <sub>H</sub>	SIR[R/W] W -----00 -----00 00000000 00000000				
00D028 <sub>H</sub>	EILS[R/W] W ----000 ----000 ----0000 00000000				
00D02C <sub>H</sub>	SILS[R/W] W -----11 -----11 11111111 11111111				
00D030 <sub>H</sub>	EIES[R/W] W ----000 ----000 ----0000 00000000				
00D034 <sub>H</sub>	EIER[R/W] W ----000 ----000 ----0000 00000000				
00D038 <sub>H</sub>	SIES[R/W] W -----00 -----00 00000000 00000000				
00D03C <sub>H</sub>	SIER[R/W] W -----00 -----00 00000000 00000000				
00D040 <sub>H</sub>	ILE[R/W] W -----00000000				
00D044 <sub>H</sub>	T0C[R/W] W --000000 00000000 -00000000 -----00				
00D048 <sub>H</sub>	T1C[R/W] W --000000 00000010 -----00				
00D04C <sub>H</sub>	STPW1[R/W] W --000000 00000000 --000000 -00000000				
00D050 <sub>H</sub>	STPW2[R] W ----000 00000000 ----000 00000000				
00D054 <sub>H</sub>   00D07C <sub>H</sub>	-	-	-	-	

# MB91580L Series

Address	Address offset value/Register name				Block
	+0	+1	+2	+3	
00D080 <sub>H</sub>	SUCC1[R/W] W ----1100 01000000 00010-00 1---0000				FlexRay SUC
00D084 <sub>H</sub>	SUCC2[R/W] W ----0001 ---00000 00000101 00000100				
00D088 <sub>H</sub>	SUCC3[R/W] W ----- ----- 00010001				
00D08C <sub>H</sub>	NEMC[R/W] W ----- -----0000				FlexRay NEM
00D090 <sub>H</sub>	PRTC1[R/W] W 000010-0 01001100 0000-110 00110011				FlexRay PRT
00D094 <sub>H</sub>	PRTC2[R/W] W --001111 00101101 --001010 --001110				
00D098 <sub>H</sub>	MHDC[R/W] W ---00000 00000000 ----- -0000000				FlexRay MHD
00D09C <sub>H</sub>	-				Reserved
00D0A0 <sub>H</sub>	GTUC1[R/W] W ----- ---0000 00000010 10000000				FlexRay GTU
00D0A4 <sub>H</sub>	GTUC2[R/W] W ----- ---0010 --000000 00001010				
00D0A8 <sub>H</sub>	GTUC3[R/W] W -0000010 -0000010 00000000 00000000				
00D0AC <sub>H</sub>	GTUC4[R/W] W --000000 00001000 --000000 00000111				
00D0B0 <sub>H</sub>	GTUC5[R/W] W 00001110 ---00000 00000000 00000000				
00D0B4 <sub>H</sub>	GTUC6[R/W] W ----000 00000010 ----000 00000000				
00D0B8 <sub>H</sub>	GTUC7[R/W] W -----00 00000010 -----00 00000100				
00D0BC <sub>H</sub>	GTUC8[R/W] W ---00000 00000000 ----- --000010				
00D0C0 <sub>H</sub>	GTUC9[R/W] W ----- -----00 ---00001 --000001				
00D0C4 <sub>H</sub>	GTUC10[R/W] W ----000 00000010 --000000 00000101				
00D0C8 <sub>H</sub>	GTUC11[R/W] W ----000 -----000 -----00 -----00				
00D0CC <sub>H</sub>   00D0FC <sub>H</sub>	-				Reserved
00D100 <sub>H</sub>	CCSV[R] W --000000 00010000 -100--00 00000000				FlexRay SUC
00D104 <sub>H</sub>	CCEV[R] W ----- ----- --00000 00--0000				
00D108 <sub>H</sub> 00D10C <sub>H</sub>	-				Reserved
00D110 <sub>H</sub>	SCV[R] W ----000 00000000 ----000 00000000				FlexRay GTU
00D114 <sub>H</sub>	MTCCV[R] W ----- --000000 --000000 00000000				
00D118 <sub>H</sub>	RCV[R] W ----- -----0000 00000000				
00D11C <sub>H</sub>	OCV[R] W ----- ---000 00000000 00000000				

# MB91580L Series

Address	Address offset value/Register name				Block
	+0	+1	+2	+3	
00D120 <sub>H</sub>	SFS[R] W -----0000 00000000 00000000				FlexRay GTU
00D124 <sub>H</sub>	SWNIT[R] W -----0000 00000000				
00D128 <sub>H</sub>	ACS[R/W] W -----000000 ---000000				
00D12C <sub>H</sub>	-				
00D130 <sub>H</sub>	ESID1[R] W -----00----00 00000000				
00D134 <sub>H</sub>	ESID2[R] W -----00----00 00000000				
00D138 <sub>H</sub>	ESID3[R] W -----00----00 00000000				
00D13C <sub>H</sub>	ESID4[R] W -----00----00 00000000				
00D140 <sub>H</sub>	ESID5[R] W -----00----00 00000000				
00D144 <sub>H</sub>	ESID6[R] W -----00----00 00000000				
00D148 <sub>H</sub>	ESID7[R] W -----00----00 00000000				
00D14C <sub>H</sub>	ESID8[R] W -----00----00 00000000				
00D150 <sub>H</sub>	ESID9[R] W -----00----00 00000000				
00D154 <sub>H</sub>	ESID10[R] W -----00----00 00000000				
00D158 <sub>H</sub>	ESID11[R] W -----00----00 00000000				
00D15C <sub>H</sub>	ESID12[R] W -----00----00 00000000				
00D160 <sub>H</sub>	ESID13[R] W -----00----00 00000000				
00D164 <sub>H</sub>	ESID14[R] W -----00----00 00000000				
00D168 <sub>H</sub>	ESID15[R] W -----00----00 00000000				
00D16C <sub>H</sub>	-				
00D170 <sub>H</sub>	OSID1[R] W -----00----00 00000000				
00D174 <sub>H</sub>	OSID2[R] W -----00----00 00000000				
00D178 <sub>H</sub>	OSID3[R] W -----00----00 00000000				
00D17C <sub>H</sub>	OSID4[R] W -----00----00 00000000				
00D180 <sub>H</sub>	OSID5[R] W -----00----00 00000000				
00D184 <sub>H</sub>	OSID6[R] W -----00----00 00000000				
00D188 <sub>H</sub>	OSID7[R] W -----00----00 00000000				
00D18C <sub>H</sub>	OSID8[R] W -----00----00 00000000				

# MB91580L Series

Address	Address offset value/Register name				Block
	+0	+1	+2	+3	
00D190 <sub>H</sub>	OSID9[R] W ----- 00----00 00000000				FlexRay GTU
00D194 <sub>H</sub>	OSID10[R] W ----- 00----00 00000000				
00D198 <sub>H</sub>	OSID11[R] W ----- 00----00 00000000				
00D19C <sub>H</sub>	OSID12[R] W ----- 00----00 00000000				
00D1A0 <sub>H</sub>	OSID13[R] W ----- 00----00 00000000				
00D1A4 <sub>H</sub>	OSID14[R] W ----- 00----00 00000000				
00D1A8 <sub>H</sub>	OSID15[R] W ----- 00----00 00000000				
00D1AC <sub>H</sub>	-				Reserved
00D1B0 <sub>H</sub>	NMV1[R] W 00000000 00000000 00000000 00000000				FlexRay NEM
00D1B4 <sub>H</sub>	NMV2[R] W 00000000 00000000 00000000 00000000				
00D1B8 <sub>H</sub>	NMV3[R] W 00000000 00000000 00000000 00000000				
00D1BC <sub>H</sub>   00D2FC <sub>H</sub>	-				Reserved
00D300 <sub>H</sub>	MRC[R/W] W ----001 10000000 00000000 00000000				FlexRay MHD
00D304 <sub>H</sub>	FRF[R/W] W -----1 10000000 ---00000 00000000				
00D308 <sub>H</sub>	FRFM[R/W] W ----- ---00000 000000--				
00D30C <sub>H</sub>	FCL[R/W] W ----- 10000000				
00D310 <sub>H</sub>	MHDS[R/W] W -0000000 -0000000 -0000000 10000000				
00D314 <sub>H</sub>	LDTS[R] W ----000 00000000 ----000 00000000				
00D318 <sub>H</sub>	FSR[R] W ----- 00000000 ----000				
00D31C <sub>H</sub>	MHDF[R/W] W -----0 00000000				
00D320 <sub>H</sub>	TXRQ1[R] W 00000000 00000000 00000000 00000000				
00D324 <sub>H</sub>	TXRQ2[R] W 00000000 00000000 00000000 00000000				
00D328 <sub>H</sub>	TXRQ3[R] W 00000000 00000000 00000000 00000000				
00D32C <sub>H</sub>	TXRQ4[R] W 00000000 00000000 00000000 00000000				
00D330 <sub>H</sub>	NDAT1[R] W 00000000 00000000 00000000 00000000				
00D334 <sub>H</sub>	NDAT2[R] W 00000000 00000000 00000000 00000000				
00D338 <sub>H</sub>	NDAT3[R] W 00000000 00000000 00000000 00000000				

# MB91580L Series

Address	Address offset value/Register name				Block
	+0	+1	+2	+3	
00D33C <sub>H</sub>	NDAT4[R] W 00000000 00000000 00000000 00000000				FlexRay MHD
00D340 <sub>H</sub>	MBSC1[R] W 00000000 00000000 00000000 00000000				
00D344 <sub>H</sub>	MBSC2[R] W 00000000 00000000 00000000 00000000				
00D348 <sub>H</sub>	MBSC3[R] W 00000000 00000000 00000000 00000000				
00D34C <sub>H</sub>	MBSC4[R] W 00000000 00000000 00000000 00000000				
00D350 <sub>H</sub>   00D3EC <sub>H</sub>	-				Reserved
00D3F0 <sub>H</sub>	CREL[R] W 00010000 00111001 00000010 00000110				FlexRay GIF
00D3F4 <sub>H</sub>	ENDN[R] W 10000111 01100101 01000011 00100001				
00D3F8 <sub>H</sub>   00D3FC <sub>H</sub>	-				Reserved
00D400 <sub>H</sub>   00D4FC <sub>H</sub>	WRDSn[1-64][R/W] W 00000000 00000000 00000000 00000000				FlexRay IBF
00D500 <sub>H</sub>	WRHS1[R/W] W --000000 -00000000 ----000 00000000				
00D504 <sub>H</sub>	WRHS2[R/W] W -----00000000 ----000 00000000				
00D508 <sub>H</sub>	WRHS3[R/W] W -----00000000 ----000 00000000				
00D50C <sub>H</sub>	-				
00D510 <sub>H</sub>	IBCM[R/W] W -----00000000 ----000 00000000				
00D514 <sub>H</sub>	IBCR[R/W] W 0-----00000000 0-----000 00000000				
00D518 <sub>H</sub>   00D5FC <sub>H</sub>	-				Reserved
00D600 <sub>H</sub>   00D6FC <sub>H</sub>	RDDS <sub>n</sub> [1-64][R] W 00000000 00000000 00000000 00000000				FlexRay OBF
00D700 <sub>H</sub>	RDHS1[R] W --000000 -00000000 ----000 00000000				
00D704 <sub>H</sub>	RDHS2[R] W -0000000 -00000000 ----000 00000000				
00D708 <sub>H</sub>	RDHS3[R] W --000000 --000000 ----000 00000000				
00D70C <sub>H</sub>	MBS[R] W --000000 --000000 00-000000 00000000				
00D710 <sub>H</sub>	OBCM[R/W] W -----00000000 ----000 00000000				
00D714 <sub>H</sub>	OBCR[R/W] W -----00000000 0-----000 00000000				
00D718 <sub>H</sub>   00D7FC <sub>H</sub>	-				Reserved

# MB91580L Series

Address	Address offset value/Register name				Block
	+0	+1	+2	+3	
00D80 <sub>H</sub>   00EFC <sub>H</sub>	-				Reserved
00F00 <sub>H</sub>   00FEFC <sub>H</sub>	-				Reserved [S]
00FF0 <sub>H</sub>	DSUCR[R/W] B,H,W -----0		-	-	OCDU [S]
00FF04 <sub>H</sub>   00FF0C <sub>H</sub>	-	-	-	-	Reserved [S]
00FF10 <sub>H</sub>	PCSR[R/W] B,H,W XXXXXXXXXXXXXXXXXXXXXXXXXXXXXXXX				OCDU [S]
00FF14 <sub>H</sub>	PSSR[R/W] B,H,W XXXXXXXXXXXXXXXXXXXXXXXXXXXXXXXX				
00FF18 <sub>H</sub>   00FFF4 <sub>H</sub>	-	-	-	-	Reserved [S]
00FFF8 <sub>H</sub>	EDIR1[R] B,H,W XXXXXXXXXXXXXXXXXXXXXXXXXXXXXXXX				OCDU [S]
00FFFC <sub>H</sub>	EDIR0[R] B,H,W XXXXXXXXXXXXXXXXXXXXXXXXXXXXXXXX				

[S]: It is a system register. The illegal instruction exception (data access error) is generated when reading and writing to these registers in the user mode.

## ■ INTERRUPT VECTOR TABLE

Interrupt factor	Interrupt number		Interrupt level	Offset	TBR default address	RN <sup>*1</sup>	Interrupt request batch read target
	Decimal	Hexadecimal					
Reset	0	00	-	3FC <sub>H</sub>	000FFFC <sub>H</sub>	-	-
System reserved	1	01	-	3F8 <sub>H</sub>	000FFF8 <sub>H</sub>	-	-
System reserved	2	02	-	3F4 <sub>H</sub>	000FFF4 <sub>H</sub>	-	-
System reserved	3	03	-	3F0 <sub>H</sub>	000FFF0 <sub>H</sub>	-	-
System reserved	4	04	-	3EC <sub>H</sub>	000FFEC <sub>H</sub>	-	-
FPU exception	5	05	-	3E8 <sub>H</sub>	000FFE8 <sub>H</sub>	-	-
Instruction access protection violation exception	6	06	-	3E4 <sub>H</sub>	000FFE4 <sub>H</sub>	-	-
Data access protection violation exception	7	07	-	3E0 <sub>H</sub>	000FFE0 <sub>H</sub>	-	-
Data access error interrupts	8	08	-	3DC <sub>H</sub>	000FFDC <sub>H</sub>	-	-
INTE instruction	9	09	-	3D8 <sub>H</sub>	000FFD8 <sub>H</sub>	-	-
Instruction break	10	0A	-	3D4 <sub>H</sub>	000FFD4 <sub>H</sub>	-	-
System reserved	11	0B	-	3D0 <sub>H</sub>	000FFD0 <sub>H</sub>	-	-
System reserved	12	0C	-	3CC <sub>H</sub>	000FFCC <sub>H</sub>	-	-
System reserved	13	0D	-	3C8 <sub>H</sub>	000FFC8 <sub>H</sub>	-	-
Exception of invalid instruction	14	0E	-	3C4 <sub>H</sub>	000FFC4 <sub>H</sub>	-	-
NMI request Error generation at internal bus diagnosis RAM double-bit error Backup RAM double-bit error RDC abnormality <sup>*5</sup>	15	0F	15(F <sub>H</sub> ) Fixed	3C0 <sub>H</sub>	000FFC0 <sub>H</sub>	-	○
External interrupt 0-7	16	10	ICR00	3BC <sub>H</sub>	000FFBC <sub>H</sub>	0	-
Reload timer 0 / 1	17	11	ICR01	3B8 <sub>H</sub>	000FFB8 <sub>H</sub>	1	○
Reload timer 2 / 3	18	12	ICR02	3B4 <sub>H</sub>	000FFB4 <sub>H</sub>	2	○
Multifunction serial interface ch0 (reception completed) / Multifunction serial interface ch0 (status)	19	13	ICR03	3B0 <sub>H</sub>	000FFB0 <sub>H</sub>	3 <sup>*2</sup>	○
Multifunction serial interface ch0 (transmission completed)	20	14	ICR04	3AC <sub>H</sub>	000FFAC <sub>H</sub>	4	-
Multifunction serial interface ch1 (reception completed) / Multifunction serial interface ch1 (status)	21	15	ICR05	3A8 <sub>H</sub>	000FFA8 <sub>H</sub>	5 <sup>*2</sup>	○
Multifunction serial interface ch1 (transmission completed)	22	16	ICR06	3A4 <sub>H</sub>	000FFA4 <sub>H</sub>	6	-
Multifunction serial interface ch2 (reception completed) / Multifunction serial interface ch2 (status)	23	17	ICR07	3A0 <sub>H</sub>	000FFA0 <sub>H</sub>	7 <sup>*2</sup>	○
Multifunction serial interface ch2 (transmission completed)	24	18	ICR08	39C <sub>H</sub>	000FF9C <sub>H</sub>	8	-
Multifunction serial interface ch3 (reception completed) / Multifunction serial interface ch3 (status)	25	19	ICR09	398 <sub>H</sub>	000FF98 <sub>H</sub>	9 <sup>*2</sup>	○

# MB91580L Series

Interrupt factor	Interrupt number		Interrupt level	Offset	TBR default address	RN <sup>*1</sup>	Interrupt request batch read target
	Decimal	Hexadecimal					
Multifunction serial interface ch3 (transmission completed)	26	1A	ICR10	394 <sub>H</sub>	000FFF94 <sub>H</sub>	10	-
Multifunction serial interface ch 4 (reception completed) / Multifunction serial interface ch4 (status)	27	1B	ICR11	390 <sub>H</sub>	000FFF90 <sub>H</sub>	11 <sup>*2</sup>	○
Multifunction serial interface ch4 (transmission completed)	28	1C	ICR12	38C <sub>H</sub>	000FFF8C <sub>H</sub>	12	-
CAN 0	29	1D	ICR13	388 <sub>H</sub>	000FFF88 <sub>H</sub>	-	-
CAN 1	30	1E	ICR14	384 <sub>H</sub>	000FFF84 <sub>H</sub>	-	-
CAN 2 / FlexRay 0	31	1F	ICR15	380 <sub>H</sub>	000FFF80 <sub>H</sub>	-	○
FlexRay 1	32	20	ICR16	37C <sub>H</sub>	000FFF7C <sub>H</sub>	-	-
FlexRay timer 0	33	21	ICR17	378 <sub>H</sub>	000FFF78 <sub>H</sub>	-	-
FlexRay timer 1	34	22	ICR18	374 <sub>H</sub>	000FFF74 <sub>H</sub>	-	-
RAM diagnosis completed RAM initialization completed Error generation at RAM diagnosis Backup RAM diagnosis completed Backup RAM initialization completed Error generation at Backup RAM diagnosis	35	23	ICR19	370 <sub>H</sub>	000FFF70 <sub>H</sub>	-	○
Main timer/PLL timer/PLL gear for FlexRay/PLL alarm for FlexRay	36	24	ICR20	36C <sub>H</sub>	000FFF6C <sub>H</sub>	20 <sup>*3</sup>	○
Clock calibration unit (CR oscillation)	37	25	ICR21	368 <sub>H</sub>	000FFF68 <sub>H</sub>	-	-
U/D counter 0 / 1	38	26	ICR22	364 <sub>H</sub>	000FFF64 <sub>H</sub>	22	○
Free-run timer 0 (0 detection) / (compare clear)	39	27	ICR23	360 <sub>H</sub>	000FFF60 <sub>H</sub>	23	○
Free-run timer 1 (0 detection) / (compare clear)	40	28	ICR24	35C <sub>H</sub>	000FFF5C <sub>H</sub>	24	○
Free-run timer 2 (0 detection) / (compare clear) PPG 0 / 1 / 2 / 3	41	29	ICR25	358 <sub>H</sub>	000FFF58 <sub>H</sub>	25	○
Free-run timer 3 (0 detection) / (compare clear)	42	2A	ICR26	354 <sub>H</sub>	000FFF54 <sub>H</sub>	26	○
Free-run timer 4 (0 detection) / (compare clear)	43	2B	ICR27	350 <sub>H</sub>	000FFF50 <sub>H</sub>	27	○
Free-run timer 5 (0 detection) / (compare clear) PPG 4 / 5 / 6 / 7	44	2C	ICR28	34C <sub>H</sub>	000FFF4C <sub>H</sub>	28	○
ICU 0 (fetching) / ICU 1 (fetching) PPG 8 / 9 / 10 / 11	45	2D	ICR29	348 <sub>H</sub>	000FFF48 <sub>H</sub>	29	○
ICU 2 (fetching) / ICU 3 (fetching) PPG 12 / 13 / 14 / 15	46	2E	ICR30	344 <sub>H</sub>	000FFF44 <sub>H</sub>	30	○
ICU 4 (fetching) / ICU 5 (fetching) PPG 16 / 17 / 18 / 19	47	2F	ICR31	340 <sub>H</sub>	000FFF40 <sub>H</sub>	31	○
ICU 6 (fetching) / ICU 7 (fetching) PPG 20 / 21 / 22 / 23	48	30	ICR32	33C <sub>H</sub>	000FFF3C <sub>H</sub>	32	○
OCU 0 (match) / OCU 1 (match)	49	31	ICR33	338 <sub>H</sub>	000FFF38 <sub>H</sub>	33	○
OCU 2 (match) / OCU 3 (match)	50	32	ICR34	334 <sub>H</sub>	000FFF34 <sub>H</sub>	34	○
OCU 4 (match) / OCU 5 (match)	51	33	ICR35	330 <sub>H</sub>	000FFF30 <sub>H</sub>	35	○



Interrupt factor	Interrupt number		Interrupt level	Offset	TBR default address	RN <sup>*1</sup>	Interrupt request batch read target
	Decimal	Hexadecimal					
OCU 6 (match) / OCU 7 (match)	52	34	ICR36	32C <sub>H</sub>	000FFF2C <sub>H</sub>	36	○
OCU 8 (match) / OCU 9 (match)	53	35	ICR37	328 <sub>H</sub>	000FFF28 <sub>H</sub>	37	○
OCU 10 (match) / OCU 11 (match)	54	36	ICR38	324 <sub>H</sub>	000FFF24 <sub>H</sub>	38	○
WG dead timer underflow 0 / 1 / 2 WG dead timer reload 0 / 1 / 2 WG DTTI 0	55	37	ICR39	320 <sub>H</sub>	000FFF20 <sub>H</sub>	39	○
WG dead timer underflow 3 / 4 / 5 WG dead timer reload 3 / 4 / 5 WG DTTI 1	56	38	ICR40	31C <sub>H</sub>	000FFF1C <sub>H</sub>	40	○
AD converter 0 / 1 / 2 / 3 / 4 / 5 / 6 / 7	57	39	ICR41	318 <sub>H</sub>	000FFF18 <sub>H</sub>	41	○
AD converter 8 / 9 / 10 / 11 / 12 / 13 / 14 / 15	58	3A	ICR42	314 <sub>H</sub>	000FFF14 <sub>H</sub>	42	○
AD converter 16 / 17 / 18 / 19 / 20 / 21 / 22 / 23	59	3B	ICR43	310 <sub>H</sub>	000FFF10 <sub>H</sub>	43	○
Base timer 0 IRQ 0/ base timer 0 IRQ 1	60	3C	ICR44	30C <sub>H</sub>	000FFF0C <sub>H</sub>	44	○
Base timer 1 IRQ 0/ base timer 1 IRQ 1	61	3D	ICR45	308 <sub>H</sub>	000FFF08 <sub>H</sub>	45	○
DMAC 0 / 1 / 2 / 3 / 4 / 5 / 6 / 7	62	3E	ICR46	304 <sub>H</sub>	000FFF04 <sub>H</sub>	-	○
Delay interrupt	63	3F	ICR47	300 <sub>H</sub>	000FFF00 <sub>H</sub>	-	-
System reserved (Used for REALOS <sup>*4</sup> .)	64	40	-	2FC <sub>H</sub>	000FFEFC <sub>H</sub>	-	-
System reserved (Used for REALOS <sup>*4</sup> .)	65	41	-	2F8 <sub>H</sub>	000FFE8 <sub>H</sub>	-	-
Used with the INT instruction.	66   255	42   FF	-	2F4 <sub>H</sub>   000 <sub>H</sub>	000FFE4 <sub>H</sub>   000FFC00 <sub>H</sub>	-	-

\*1 : Does not support a DMA transfer request caused by an interrupt generated from a peripheral to which no RN (resource number) is assigned.

\*2 : The multi-function serial interface status does not support DMA transfer caused by I<sup>2</sup>C reception.

\*3 : "PLL gear for FlexRay" and "PLL alarm for FlexRay" do not support DMA transfer.

\*4 : REALOS is a trademark of Fujitsu Semiconductor Limited, Japan.

\*5 : For RDC, the MB91F585LA/F586LA/F587LA/F585LC/F586LC/F587LC have corresponding functions.

# MB91580L Series

## ■ ELECTRICAL CHARACTERISTICS

### 1. Absolute Maximum Ratings

Parameter	Symbol	Rating		Unit	Remarks
		Min	Max		
Power supply voltage <sup>*1, *2</sup>	V <sub>CC</sub>	V <sub>SS</sub> -0.3	V <sub>SS</sub> +6.0	V	
Analog power supply voltage <sup>*1, *2</sup>	AV <sub>CC</sub>	V <sub>SS</sub> -0.3	V <sub>SS</sub> +6.0	V	Avcc ≤ Vcc
Analog reference voltage <sup>*1</sup>	AVRH	V <sub>SS</sub> -0.3	V <sub>SS</sub> +6.0	V	AVRH ≤ AV <sub>CC</sub>
Input voltage <sup>*1</sup>	V <sub>I</sub>	V <sub>SS</sub> -0.3	V <sub>CC</sub> +0.3	V	
Analog pin input voltage <sup>*1</sup>	V <sub>IA</sub>	V <sub>SS</sub> -0.3	V <sub>CC</sub> +0.3	V	
Output voltage <sup>*1</sup>	V <sub>O</sub>	V <sub>SS</sub> -0.3	V <sub>CC</sub> +0.3	V	
Maximum clamp current	I <sub>CLAMP</sub>	-	4	mA	*9
Total maximum clamp current	Σ I <sub>CLAMP</sub>	-	20	mA	*9
"L" level maximum output current <sup>*3</sup>	I <sub>OL1</sub>	-	7	mA	When setting to 2mA <sup>*6</sup>
	I <sub>OL2</sub>	-	14	mA	When setting to 4mA <sup>*7</sup>
	I <sub>OL3</sub>	-	17.5	mA	When setting to 5mA <sup>*8</sup>
"L" level average output current <sup>*4</sup>	I <sub>OLAV1</sub>	-	2	mA	When setting to 2mA <sup>*6</sup>
	I <sub>OLAV2</sub>	-	4	mA	When setting to 4mA <sup>*7</sup>
	I <sub>OLAV3</sub>	-	5	mA	When setting to 5mA <sup>*8</sup>
"L" level total output current <sup>*5</sup>	ΣI <sub>OL</sub>	-	50	mA	*6
"H" level maximum output current <sup>*3</sup>	I <sub>OH1</sub>	-	-7	mA	When setting to 2mA <sup>*6</sup>
	I <sub>OH2</sub>	-	-14	mA	When setting to 4mA <sup>*7</sup>
	I <sub>OH3</sub>	-	-17.5	mA	When setting to 5mA <sup>*8</sup>
"H" level average output current <sup>*4</sup>	I <sub>OHAV1</sub>	-	-2	mA	When setting to 2mA <sup>*6</sup>
	I <sub>OHAV2</sub>	-	-4	mA	When setting to 4mA <sup>*7</sup>
	I <sub>OHAV3</sub>	-	-5	mA	When setting to 5mA <sup>*8</sup>
"H" level total output current <sup>*5</sup>	ΣI <sub>OH</sub>	-	-50	mA	*6
Power consumption	P <sub>D</sub>	-	690	mW	
Operating temperature	T <sub>A</sub>	-40	+125	°C	*10
Storage temperature	T <sub>stg</sub>	-55	+150	°C	

\*1: These parameters are based on the condition that V<sub>SS</sub>=AV<sub>SS</sub>=0.0V.

\*2: Caution must be taken that AV<sub>CC</sub> does not exceed V<sub>CC</sub>.

\*3: The maximum output current is defined as the value of the peak current flowing through any one of the corresponding pins.

\*4: The average output current is defined as the value of the average current flowing through any one of the corresponding pins for a 10 ms period. The average value is the operation current × the operation ratio.

\*5: The total output current is defined as the maximum current value flowing through all of corresponding pins.

\*6: Corresponding pins: General-purpose ports

\*7: Corresponding pins: General-purpose ports of P003 to P007, P010

\*8: Corresponding pins: General-purpose ports other than those of P003 to P007, P010

\*9: • Corresponding pins: General-purpose ports

- Use the devices within recommended operating conditions.
- Use the devices with direct voltage (current).
- The + B signal should always be applied by connecting a limiting resistor between the + B signal and the microcontroller.
- The value of the limiting resistor should be set so that the current input to the microcontroller pin does not exceed rated values at any time regardless of instantaneously or constantly when the + B signal is input.
- Note that when the microcontroller drive current is low, such as in the low-power consumption modes, the + B input potential can increase the potential at the  $V_{CC}$  pin via a protective diode, possibly affecting other devices.
- Note that if the + B signal is input when the microcontroller is off (not fixed at 0 V), since the power is supplied through the pin, the microcontroller may operate incompletely.
- Note that if the +B signal is input at power-on, since the power is supplied through the pin, the power-on reset may not function in the power supply voltage.
- Do not leave + B input pins open.

## Sample recommended circuit

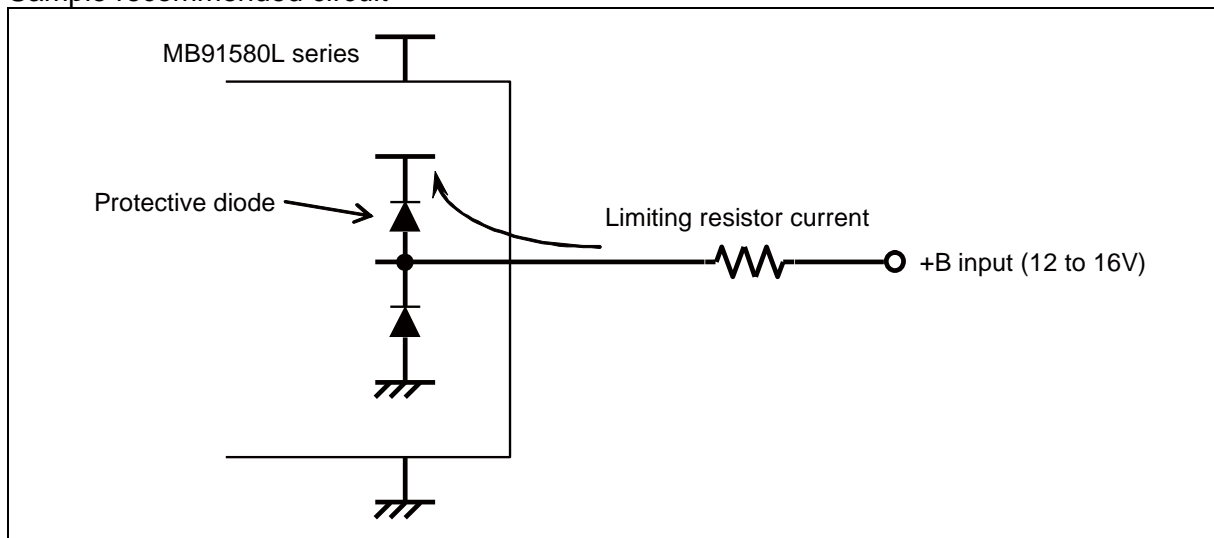

\*10: To use this product at  $T_A=125^\circ\text{C}$ , equip this on a multilayer board with four or more layers.

To equip this on a single-layer board, change the operating conditions (operating frequency, power supply voltage, etc) to use this at the power consumption  $P_D=500\text{mW}$  or lower, or use this at  $T_A=110^\circ\text{C}$  or lower.

**WARNING:** Semiconductor devices can be permanently damaged by application of stress (voltage, current, temperature, etc.) in excess of absolute maximum ratings. Do not exceed these ratings.

# MB91580L Series

## 2. Recommended operating conditions

( $V_{SS} = AV_{SS} = 0.0V$ )

Parameter	Symbol	Value		Unit	Remarks
		Min	Max		
Power supply voltage	$V_{CC}$	4.5	5.5	V	Recommended operation guarantee range
	$AV_{CC}$	4.5	5.5	V	
	$V_{CC}$	3.7	5.5	V	Operation guarantee range
	$AV_{CC}$	3.7	5.5	V	
Smoothing capacitor*	$C_S$	4.7 (tolerance within $\pm 50\%$ )		$\mu F$	Use a ceramic capacitor or a capacitor that has the similar frequency characteristics. Use a capacitor with a capacitance greater than $C_S$ as the smoothing capacitor on the VCC pin.
Operating temperature	$T_A$	-40	+125	$^{\circ}C$	

\*: For connection of smoothing capacitor  $C_S$ , see the figure below.

### • C Pin Connection Diagram

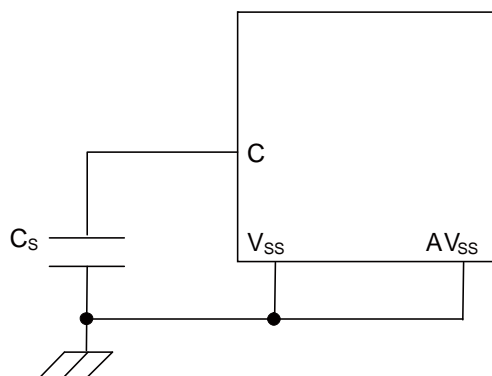

**WARNING:** The recommended operating conditions are required in order to ensure the normal operation of the semiconductor device. All of the device's electrical characteristics are warranted when the device is operated within these ranges.

Always use semiconductor devices within their recommended operating condition ranges.

Operation outside these ranges may adversely affect reliability and could result in device failure.

No warranty is made with respect to uses, operating conditions, or combinations not represented on the data sheet. Users considering application outside the listed conditions are advised to contact their representatives beforehand.

## 3. DC characteristics

(T<sub>A</sub>: Recommended operating conditions, V<sub>CC</sub>=5.0V±10%, V<sub>SS</sub>=AV<sub>SS</sub>=0.0V)

Parameter	Symbol	Pin name	Conditions	Value			Unit	Remarks
				Min	Typ	Max		
"H" level input voltage	V <sub>IH1</sub>	P000 to P002, P011 to P017, P020 to P027, P030 to P037, P040 to P042, P043 to P047*, P050 to P057*, P060 to P067, P070 to P077, P080 to P087, P090 to P097, P100 to P107, P110 to P117, P120 to P127, P130 to P134, P136 to P137	When CMOS schmitt input level is selected	0.7 × V <sub>CC</sub>	-	V <sub>CC</sub> +0.3	V	
	V <sub>IH2</sub>	P000 to P007, P010 to P017, P020 to P027, P030 to P037, P040 to P042, P043 to P047*, P050 to P057*, P060 to P067, P070 to P077, P080 to P087, P090 to P097, P100 to P107, P110 to P117, P120 to P127, P130 to P134, P136 to P137	When Automotive input level is selected	0.8 × V <sub>CC</sub>	-	V <sub>CC</sub> +0.3	V	
	V <sub>IH3</sub>	P003 to P007, P010	When FlexRay input level is selected	0.65 × V <sub>CC</sub>	-	V <sub>CC</sub> +0.3	V	
	V <sub>IH4</sub>	RSTX, NMIX	-	0.7 × V <sub>CC</sub>	-	V <sub>CC</sub> +0.3	V	
	V <sub>IH5</sub>	MD0, MD1	-	0.7 × V <sub>CC</sub>	-	V <sub>CC</sub> +0.3	V	
	V <sub>IH6</sub>	DEBUGIF	-	2.0	-	V <sub>CC</sub> +0.3	V	

\*: Only available with MB91F585LB/F586LB/F587LB, MB91F585LD/F586LD/F587LD

# MB91580L Series

(T<sub>A</sub>: Recommended operating conditions, V<sub>CC</sub>=5.0V±10%, V<sub>SS</sub>=AV<sub>SS</sub>=0.0V)

Parameter	Symbol	Pin name	Conditions	Value			Unit	Remarks
				Min	Typ	Max		
"L" level input voltage	V <sub>IL1</sub>	P000 to P002, P011 to P017, P020 to P027, P030 to P037, P040 to P042, P043 to P047*, P050 to P057*, P060 to P067, P070 to P077, P080 to P087, P090 to P097, P100 to P107, P110 to P117, P120 to P127, P130 to P134, P136 to P137	When CMOS schmitt input level is selected	V <sub>SS</sub> -0.3	-	0.3 × V <sub>CC</sub>	V	
	V <sub>IL2</sub>	P000 to P007, P010 to P017, P020 to P027, P030 to P037, P040 to P042, P043 to P047*, P050 to P057*, P060 to P067, P070 to P077, P080 to P087, P090 to P097, P100 to P107, P110 to P117, P120 to P127, P130 to P134, P136 to P137	When Automotive input level is selected	V <sub>SS</sub> -0.3	-	0.5 × V <sub>CC</sub>	V	
	V <sub>IL3</sub>	P003 to P007, P010	When FlexRay input level is selected	V <sub>SS</sub> -0.3	-	0.35 × V <sub>CC</sub>	V	
	V <sub>IL4</sub>	RSTX, NMIX	-	V <sub>SS</sub> -0.3	-	0.3 × V <sub>CC</sub>	V	
	V <sub>IL5</sub>	MD0, MD1	-	V <sub>SS</sub> -0.3	-	0.3 × V <sub>CC</sub>	V	
	V <sub>IL6</sub>	DEBUGIF	-	V <sub>SS</sub> -0.3	-	0.8	V	

\*: Only available with MB91F585LB/F586LB/F587LB, MB91F585LD/F586LD/F587LD

# MB91580L Series

(T<sub>A</sub>: Recommended operating conditions, V<sub>CC</sub>=5.0V±10%, V<sub>SS</sub>=AV<sub>SS</sub>=0.0V)

Parameter	Symbol	Pin name	Conditions	Value			Unit	Remarks
				Min	Typ	Max		
"H" level output voltage	V <sub>OH1</sub>	P000 to P007, P010 to P017, P020 to P027, P030 to P037, P040 to P042, P043 to P047*, P050 to P057*, P060 to P067, P070 to P077, P080 to P087, P090 to P097, P100 to P107, P110 to P117, P120 to P127, P130 to P134, P136 to P137	V <sub>CC</sub> =4.5V I <sub>OH</sub> =-2.0mA	V <sub>CC</sub> -0.5	-	V <sub>CC</sub>	V	
	V <sub>OH2</sub>	P003 to P007, P010	V <sub>CC</sub> =4.5V I <sub>OH</sub> =-4.0mA	V <sub>CC</sub> -0.5	-	V <sub>CC</sub>	V	When FlexRay is selected
	V <sub>OH3</sub>	P000 to P002, P011 to P017, P020 to P027, P030 to P037, P040 to P042, P043 to P047*, P050 to P057*, P060 to P067, P070 to P077, P080 to P087, P090 to P097, P100 to P107, P110 to P117, P120 to P127, P130 to P134, P136 to P137	V <sub>CC</sub> =4.5V I <sub>OH</sub> =-5.0mA	V <sub>CC</sub> -0.5	-	V <sub>CC</sub>	V	

\*: Only available with MB91F585LB/F586LB/F587LB, MB91F585LD/F586LD/F587LD

# MB91580L Series

(T<sub>A</sub>: Recommended operating conditions, V<sub>CC</sub>=5.0V±10%, V<sub>SS</sub>=AV<sub>SS</sub>=0.0V)

Parameter	Symbol	Pin name	Conditions	Value			Unit	Remarks
				Min	Typ	Max		
"L" level output voltage	V <sub>OL1</sub>	P000 to P007, P010 to P017, P020 to P027, P030 to P037, P040 to P042, P043 to P047*, P050 to P057*, P060 to P067, P070 to P077, P080 to P087, P090 to P097, P100 to P107, P110 to P117, P120 to P127, P130 to P134, P136 to P137	V <sub>CC</sub> =4.5V I <sub>OL</sub> =2.0mA	0	-	0.4	V	
	V <sub>OL2</sub>	P003 to P007, P010	V <sub>CC</sub> =4.5V I <sub>OL</sub> =4.0mA	0	-	0.4	V	When FlexRay is selected
	V <sub>OL3</sub>	P000 to P002, P011 to P017, P020 to P027, P030 to P037, P040 to P042, P043 to P047*, P050 to P057*, P060 to P067, P070 to P077, P080 to P087, P090 to P097, P100 to P107, P110 to P117, P120 to P127, P130 to P134, P136 to P137	V <sub>CC</sub> =4.5V I <sub>OL</sub> =5.0mA	0	-	0.4	V	
	V <sub>OL4</sub>	P001,P002, P021,P022, P025,P026, P073,P074, P076,P077, P127,P130	V <sub>CC</sub> =4.5V I <sub>OL</sub> =3.0mA	0	-	0.4	V	I <sup>2</sup> C shared pin (when I <sup>2</sup> C is selected)
	V <sub>OL5</sub>	DEBUGIF	V <sub>CC</sub> =2.7V I <sub>OL</sub> =25.0mA	0	-	0.25	V	

\*: Only available with MB91F585LB/F586LB/F587LB, MB91F585LD/F586LD/F587LD



# MB91580L Series

(T<sub>A</sub>: Recommended operating conditions, V<sub>CC</sub>=5.0V±10%, V<sub>SS</sub>=AV<sub>SS</sub>=0.0V)

Parameter	Symbol	Pin name	Conditions	Value			Unit	Remarks
				Min	Typ	Max		
Input Leak Current	I <sub>IL</sub>	All input pins	V <sub>CC</sub> =AV <sub>CC</sub> =5.5V V <sub>SS</sub> <V <sub>I</sub> <V <sub>CC</sub>	-5	-	+5	μA	
Pull-up resistance	R <sub>UP1</sub>	RSTX, NMIX	-	25	-	100	kΩ	
	R <sub>UP2</sub>	P000 to P007, P010 to P017, P020 to P027, P030 to P037, P040 to P042, P043 to P047*, P050 to P057*, P060 to P067, P070 to P077, P080 to P087, P090 to P097, P100 to P107, P110 to P117, P120 to P127, P130 to P134, P136 to P137	When pull-up resistance is selected	25	-	100	kΩ	
Input Capacitor	C <sub>IN</sub>	Other than VCC, VSS, AVCC, AVSS, C	-	-	5	15	pF	

\*: Only available with MB91F585LB/F586LB/F587LB, MB91F585LD/F586LD/F587LD

# MB91580L Series

(T<sub>A</sub>: Recommended operating conditions, V<sub>CC</sub>=5.0V±10%, V<sub>SS</sub>=AV<sub>SS</sub>=0.0V)

Parameter	Symbol	Pin name	Conditions	Value			Unit	Remarks
				Min	Typ	Max		
Power supply current	I <sub>CC</sub>	VCC5	Normal operations F <sub>CP</sub> =128MHz, F <sub>CPP</sub> =32MHz	-	85	110	mA	*1, *3 RDC=OFF, FlexRay =ON
				-	82	105	mA	*1, *3 RDC=ON, FlexRay =OFF
				-	85	110	mA	*2, *4 FlexRay =ON
				-	79	104	mA	*2, *4 FlexRay =OFF
			Normal operations F <sub>CP</sub> =80MHz, F <sub>CPP</sub> =40MHz	-	69	91	mA	*1, *3 RDC=OFF, FlexRay =ON
				-	67	89	mA	*1, *3 RDC=ON, FlexRay =OFF
				-	69	91	mA	*2, *4 FlexRay =ON
				-	64	87	mA	*2, *4 FlexRay =OFF
			Flash write F <sub>CP</sub> =128MHz, F <sub>CPP</sub> =32MHz	-	100	125	mA	*1, *3, *5
				-	100	125	mA	*2, *4, *5
			Flash erase F <sub>CP</sub> =128MHz, F <sub>CPP</sub> =32MHz	-	100	125	mA	*1, *3, *5
				-	100	125	mA	*2, *4, *5

\*1: MB91F585LA/F586LA/F587LA

\*2: MB91F585LB/F586LB/F587LB

\*3: MB91F585LC/F586LC/F587LC

\*4: MB91F585LD/F586LD/F587LD

\*5: This series has 2 types of flash; main flash and WorkFlash; however, this is the specification when only one of those is written/erased.

# MB91580L Series

(T<sub>A</sub>: Recommended operating conditions, V<sub>CC</sub>=5.0V±10%, V<sub>SS</sub>=AV<sub>SS</sub>=0.0V)

Parameter	Symbol	Pin name	Conditions	Value			Unit	Remarks
				Min	Typ	Max		
Power supply current	I <sub>CCS</sub>	VCC5	CPU sleep F <sub>CP</sub> =128MHz, F <sub>CPP</sub> =32MHz	-	46	68	mA	*1, *2, *3, *4
	I <sub>CCBS</sub>		Bus sleep F <sub>CP</sub> =128MHz, F <sub>CPP</sub> =32MHz	-	31	54	mA	*1, *2, *3, *4
	I <sub>CCT</sub>		Clock mode 4MHz source oscillation	-	1.2	1.8	mA	When using external clock*6 T <sub>A</sub> =25°C, *1, *2, *3, *4
				-	2.7	3.3	mA	When using crystal T <sub>A</sub> =25°C, *1, *2, *3, *4
	I <sub>CCTS</sub>		Clock mode shutdown 4MHz source oscillation	-	0.7	0.8	mA	When using external clock*6 T <sub>A</sub> =25°C, *3, *4
				-	2.2	2.3	mA	When using crystal T <sub>A</sub> =25°C, *3, *4
				-	0.3	0.4	mA	When using external clock*6 T <sub>A</sub> =25°C, *1, *2
				-	1.8	1.9	mA	When using crystal T <sub>A</sub> =25°C, *1, *2
	I <sub>CCH</sub>		STOP mode	-	1.0	1.6	mA	T <sub>A</sub> =25°C, *3, *4
				-	0.6	1.1	mA	T <sub>A</sub> =25°C, *1, *2
	I <sub>CCHS</sub>		STOP mode shutdown	-	0.5	0.6	mA	T <sub>A</sub> =25°C, *3, *4
-		0.1		0.2	mA	T <sub>A</sub> =25°C, *1, *2		

\*1: MB91F585LA/F586LA/F587LA

\*2: MB91F585LB/F586LB/F587LB

\*3: MB91F585LC/F586LC/F587LC

\*4: MB91F585LD/F586LD/F587LD

\*6: The power supply current is the current value when the external clock is supplied from the X1 pin. Note that the power supply current value when using the external clock is different from that using the oscillator.

# MB91580L Series

## 4. AC characteristics

### (1) Main Clock Timing

(T<sub>A</sub>: Recommended operating conditions, V<sub>CC</sub>=5.0V±10%, V<sub>SS</sub>=AV<sub>SS</sub>=0.0V)

Parameter	Symbol	Pin name	Conditions	Value			Unit	Remarks
				Min	Typ	Max		
Source oscillation clock frequency	F <sub>C</sub>	X0, X1	-	4	-	20	MHz	
Source oscillation clock cycle time	t <sub>CYL</sub>	X0, X1	-	50	-	250	ns	
Internal operating clock frequency*	F <sub>CP</sub>	-	-	-	-	128	MHz	CPU clock
	F <sub>CPP</sub>	-	-	-	-	40	MHz	Peripheral bus clock
	F <sub>CPT</sub>	-	-	-	-	40	MHz	External bus clocks
Internal operating clock cycle time*	t <sub>CP</sub>	-	-	7.82	-	-	ns	CPU clock
	t <sub>CPP</sub>	-	-	25	-	-	ns	Peripheral bus clock
	t <sub>CPT</sub>	-	-	25	-	-	ns	External bus clocks
CAN PLL jitter (during lock)	t <sub>PJ</sub>	-	-	-10	-	+10	ns	F <sub>CP</sub> =80MHz (4MHz multiplied by 20)
Built-in CR oscillation frequency	F <sub>CCR</sub>	-	-	90	100	110	kHz	

\*: The maximum/minimum value is defined when using the main clock and PLL clock.

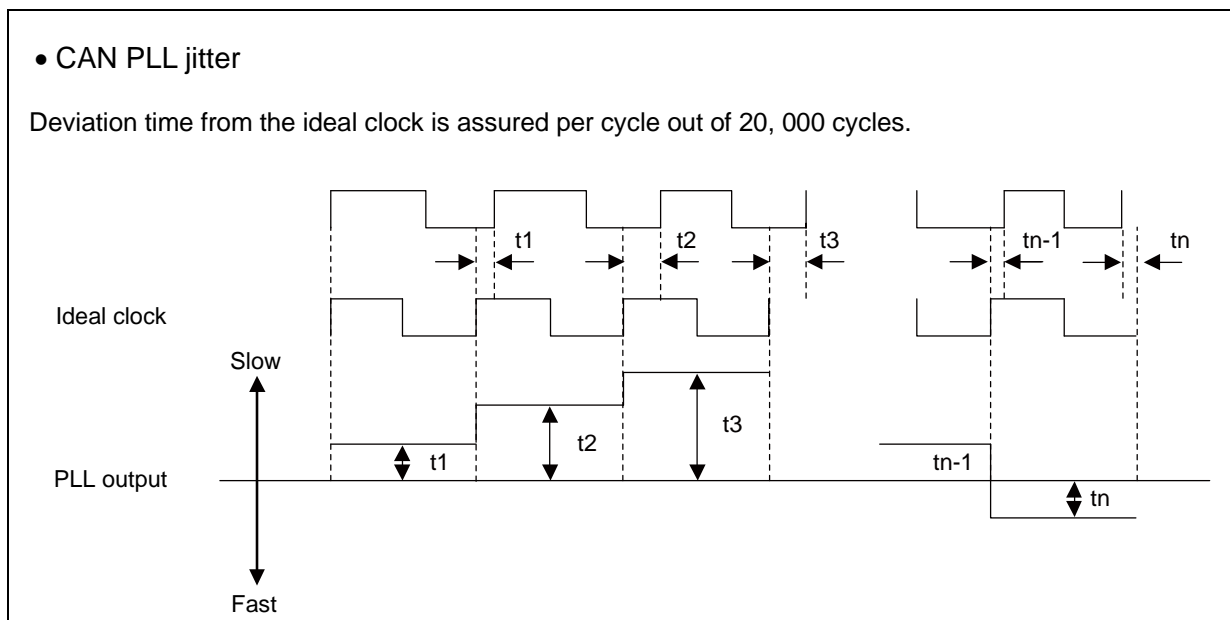
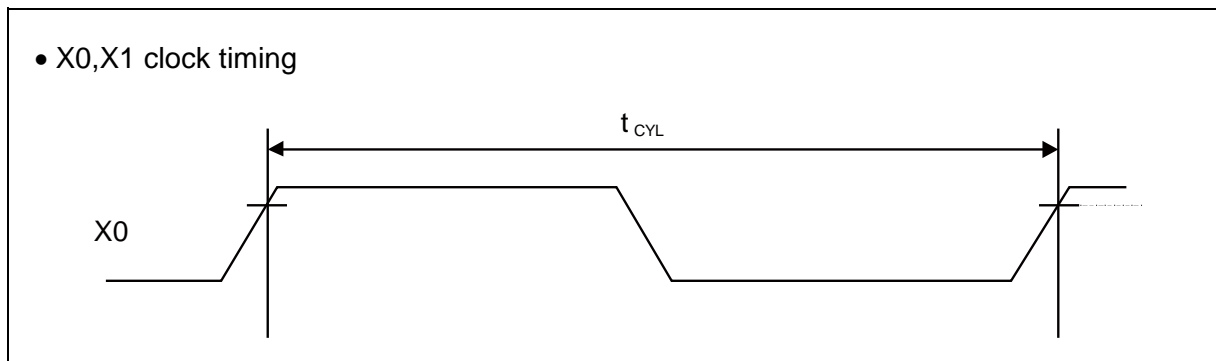

- Guaranteed operation range

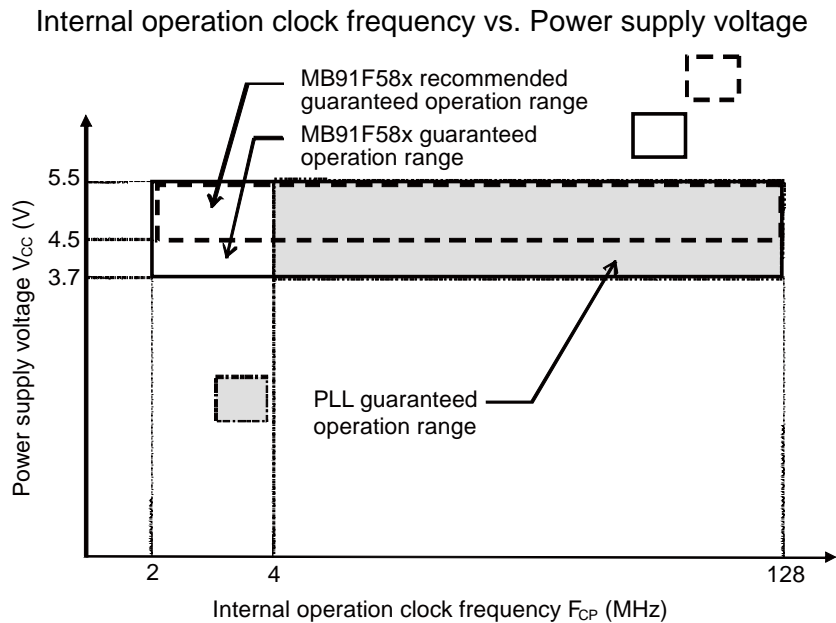

Note: The CPU will be reset at the power supply voltage of the low-voltage detection setting voltage or less.

### Oscillation clock frequency vs. Internal operation clock frequency

	4MHz	Internal operation clock frequency							
		Main clock	PLL clock						
			Multiplied by 1	Multiplied by 2	Multiplied by 3	Multiplied by 4	...	Multiplied by 20	...
Oscillation clock frequency	2MHz	4MHz	8MHz	12MHz	16MHz	...	80MHz	...	128MHz

- Example of oscillation circuit

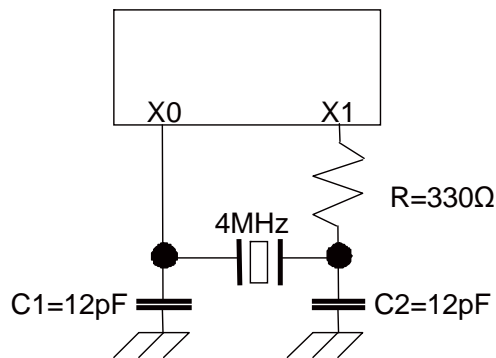

Note: If it is impossible to start the oscillation within or equal to 20ms when starting from the oscillation stop state, the clock supervisor performs a detection of oscillation stop and moves to the fail safe operation.

Design your print circuit board so that the oscillator can start oscillation within 20ms. In addition, when configuring the oscillator circuit, it is recommended to ask matching evaluation of the circuit to oscillator manufacturers for the design.

# MB91580L Series

AC characteristics are specified by the following measurement reference voltage values.

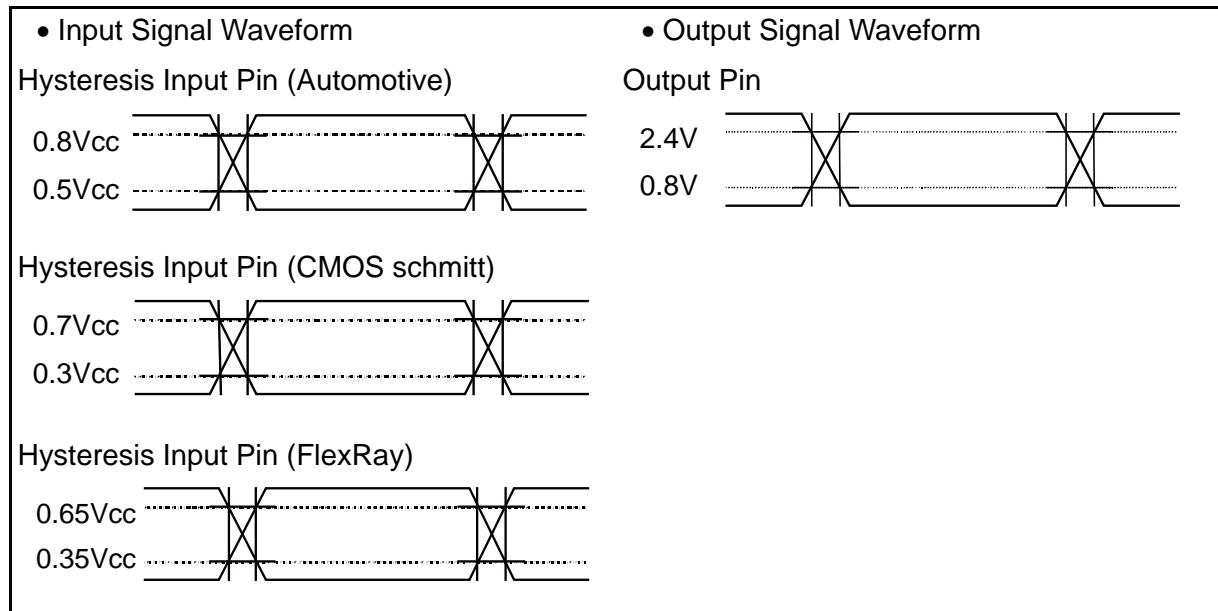

## (2) Reset input

(T<sub>A</sub>: Recommended operating conditions, V<sub>CC</sub> = 5.0V ± 10%, V<sub>SS</sub> = AV<sub>SS</sub> = 0.0V)

Parameter	Symbol	Pin name	Conditions	Value		Unit	Remarks
				Min	Max		
Reset input time	t <sub>RSTL</sub>	RSTX	-	10	-	μs	During normal operation
				Oscillation time of oscillator* +0.1	-	ms	At Stop mode
				100	-	μs	At Clock mode
Width for reset input removal				1	-	μs	

\*: The oscillation time of the oscillator is the time it takes for the amplitude of the oscillations to reach 90%. For crystal oscillators, this time is between several ms and several tens of ms, for ceramic oscillators the time is between several hundred μs and several ms, and for an external clock, the time is 0 ms.

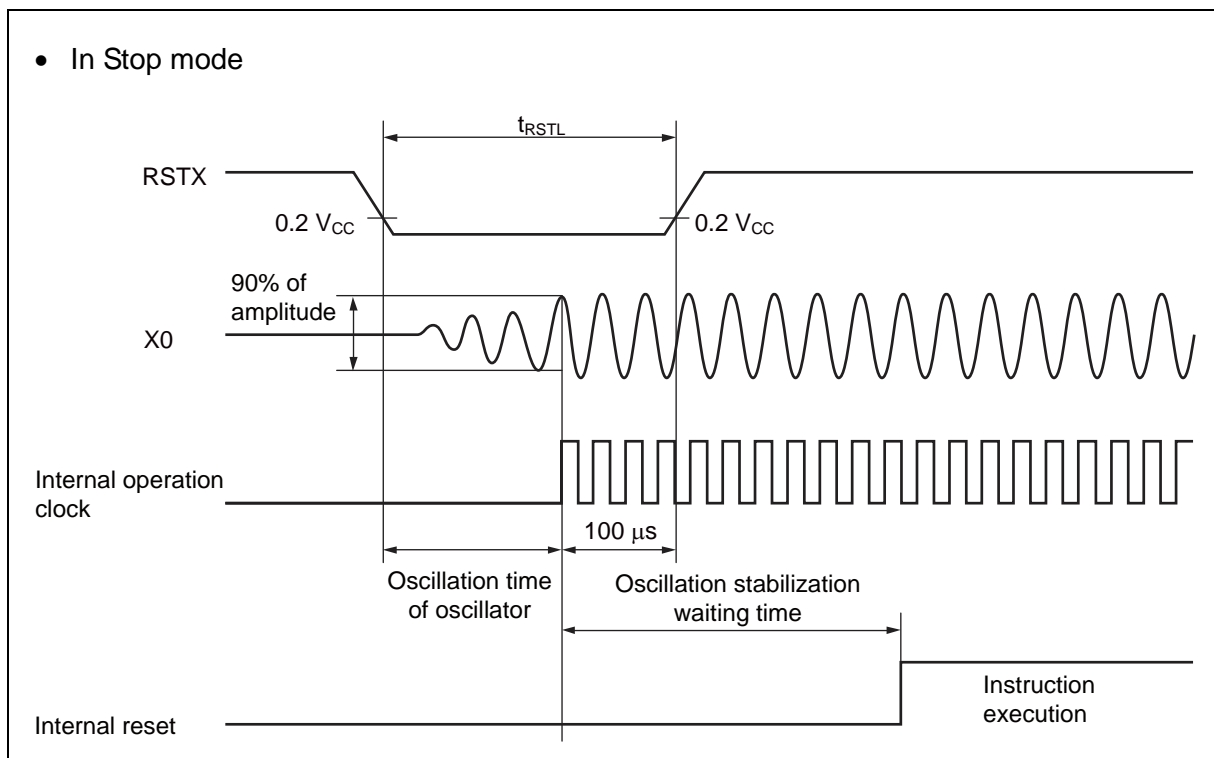
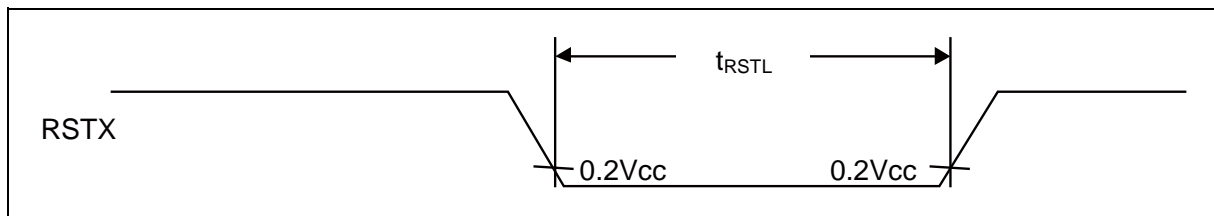

# MB91580L Series

## (3) Power-on Conditions

(T<sub>A</sub>: Recommended operating conditions, V<sub>SS</sub>=0.0V)

Parameter	Symbol	Pin name	Conditions	Value			Unit	Remarks
				Min	Typ	Max		
Level detection voltage	-	VCC5	-	2.1	2.3	2.5	V	When turning on power
Level detection hysteresis width	-	VCC5	-	-	-	125	mV	During voltage drop
Level detection time	-	-	-	-	-	30	μs	*1
Slope detection undetected standard	-	VCC5	V <sub>CC</sub> = at level detection release level	-	-	4	mV/μs	*2
Power off time	t <sub>OFF</sub>	VCC5	-	50	-	-	ms	*3

\*1: If the fluctuation of the power supply is faster than the low-voltage detection time, there is the possibility to generate or release after the power supply voltage has exceeded the detection voltage range.

\*2: When setting the power supply fluctuation to this standard or less, it is possible to suppress the slope detection. This is the standard when the power supply fluctuation is stable.

\*3: This time is to start the slope detection at next power on after power down and internal charge loss.



(4) Multi-function Serial

(4-1) CSIO timing (SMR:MD2-0="010"b)

(4-1-1) Normal synchronous transfer (SCR:SPI=0) and serial clock output signal detect level "H"  
(SMR:SCINV=0)

(T<sub>A</sub>: Recommended operating conditions, V<sub>CC</sub>=5.0V±10%, V<sub>SS</sub>=AV<sub>SS</sub>=0.0V)

Parameter	Symbol	Pin name	Conditions	Value		Unit	Remarks
				Min	Max		
Serial clock cycle time	t <sub>SCYC</sub>	SCK0 to SCK4, SCK3_1,SCK4_1	Master mode C <sub>L</sub> =50pF	4t <sub>CPP</sub>	-	ns	
SCK ↓ ⇒ SOT delay time	t <sub>SLOVI</sub>	SCK0 to SCK4, SCK3_1,SCK4_1, SOT0 to SOT4, SOT3_1,SOT4_1		-30	+30	ns	
Valid SIN ⇒ SCK ↑ setup time	t <sub>IVSHI</sub>	SCK0 to SCK4, SCK3_1, SCK4_1,		30	-	ns	
SCK ↑ ⇒ Valid SIN hold time	t <sub>SHIXI</sub>	SIN0 to SIN4, SIN3_1, SIN4_1		0	-	ns	
Serial clock "H" pulse width	t <sub>SHSL</sub>	SCK0 to SCK4, SCK3_1, SCK4_1	Slave mode C <sub>L</sub> =50pF	t <sub>CPP</sub> +10	-	ns	
Serial clock "L" pulse width	t <sub>SLSH</sub>			2t <sub>CPP</sub> -10	-	ns	
SCK ↓ ⇒ SOT delay time	t <sub>SLOVE</sub>	SCK0 to SCK4, SCK3_1,SCK4_1, SOT0 to SOT4, SOT3_1,SOT4_1		-	30	ns	
Valid SIN ⇒ SCK ↑ setup time	t <sub>IVSHE</sub>	SCK0 to SCK4, SCK3_1, SCK4_1,		10	-	ns	
SCK ↑ ⇒ Valid SIN hold time	t <sub>SHIXE</sub>	SIN0 to SIN4, SIN3_1, SIN4_1		20	-	ns	
SCK fall time	t <sub>F</sub>	SCK0 to SCK4, SCK3_1, SCK4_1		-	5	ns	
SCK rise time	t <sub>R</sub>	SCK0 to SCK4, SCK3_1, SCK4_1		-	5	ns	

- Notes:
- This is the AC characteristic in CLK synchronized mode.
  - C<sub>L</sub> is the load capacitance applied to pins during testing.
  - The maximum baud rate is limited by the internal operation clock used and other parameters. See Hardware Manual for details.

# MB91580L Series

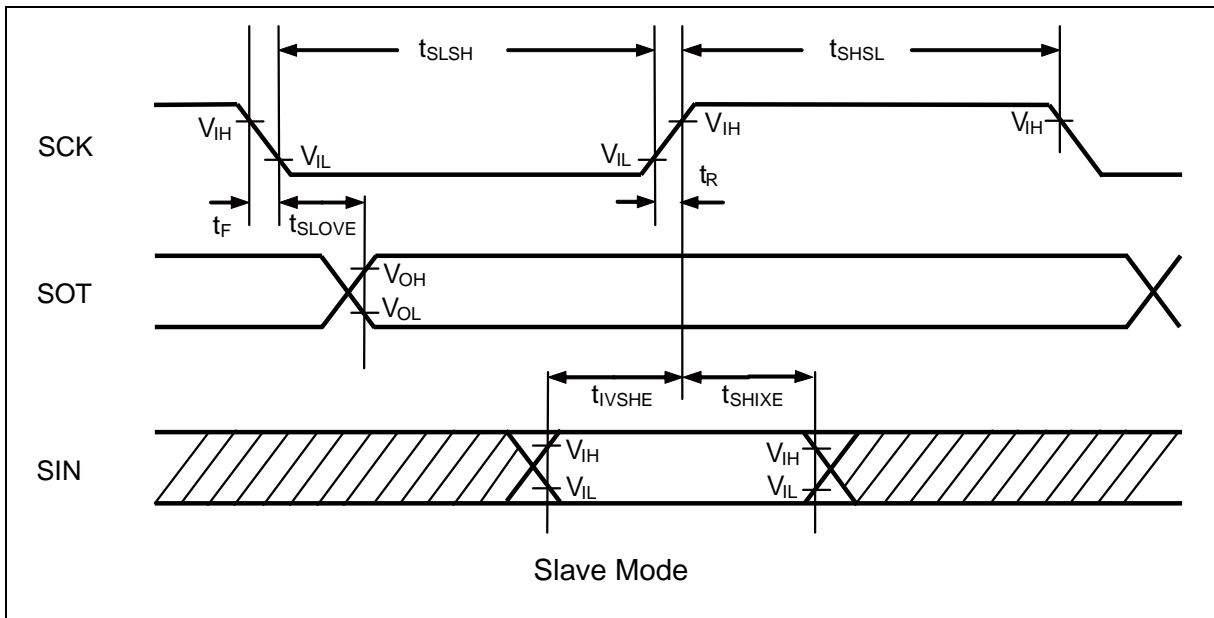
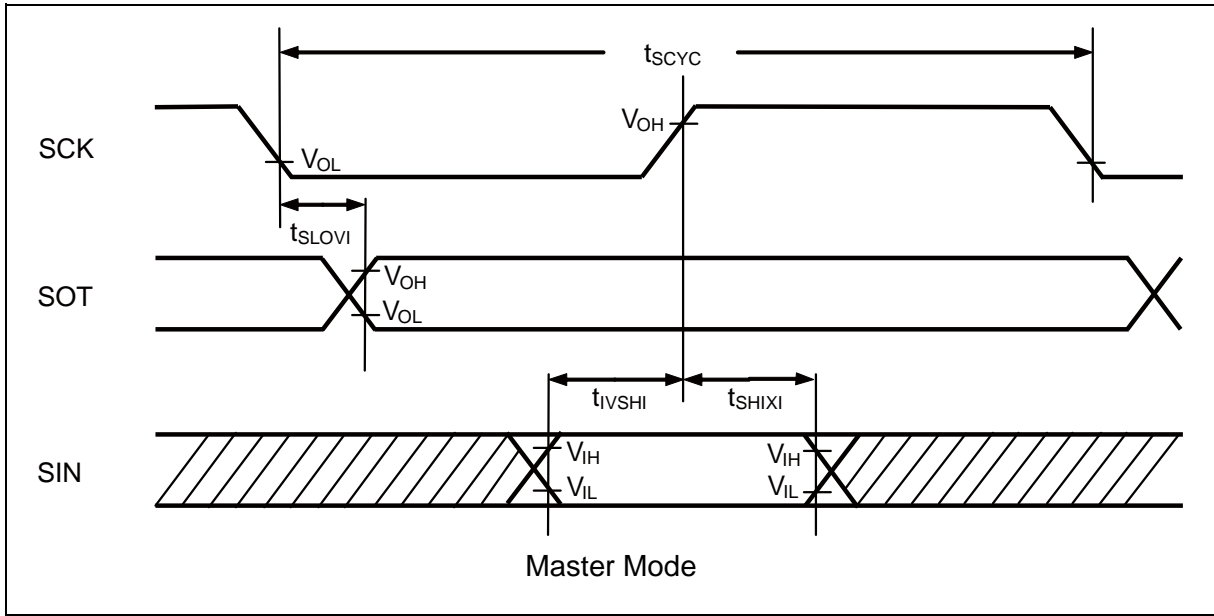

(4-1-2) Normal synchronous transfer (SCR:SPI=0) and serial clock output signal detect level  
"L"(SMR:SCINV=1)

(T<sub>A</sub>: Recommended operating conditions, V<sub>CC</sub>=5.0V±10%, V<sub>SS</sub>=AV<sub>SS</sub>=0.0V)

Parameter	Symbol	Pin name	Conditions	Value		Unit	Remarks
				Min	Max		
Serial clock cycle time	t <sub>SCYC</sub>	SCK0 to SCK4, SCK3_1,SCK4_1	Master mode C <sub>L</sub> =50pF	4t <sub>CPP</sub>	-	ns	
SCK ↑ ⇒ SOT delay time	t <sub>SHOVI</sub>	SCK0 to SCK4, SCK3_1,SCK4_1, SOT0 to SOT4, SOT3_1,SOT4_1		-30	+30	ns	
Valid SIN ⇒ SCK ↓ setup time	t <sub>IVSLI</sub>	SCK0 to SCK4, SCK3_1, SCK4_1,		30	-	ns	
SCK ↓ ⇒ Valid SIN hold time	t <sub>SLIXI</sub>	SIN0 to SIN4, SIN3_1, SIN4_1		0	-	ns	
Serial clock "H" pulse width	t <sub>SHSL</sub>	SCK0 to SCK4, SCK3_1, SCK4_1	Slave mode C <sub>L</sub> =50pF	t <sub>CPP</sub> +10	-	ns	
Serial clock "L" pulse width	t <sub>SLSH</sub>			2t <sub>CPP</sub> -10	-	ns	
SCK ↑ ⇒ SOT delay time	t <sub>SHOVE</sub>	SCK0 to SCK4, SCK3_1,SCK4_1, SOT0 to SOT4, SOT3_1,SOT4_1		-	30	ns	
Valid SIN ⇒ SCK ↓ setup time	t <sub>IVSLE</sub>	SCK0 to SCK4, SCK3_1, SCK4_1,		10	-	ns	
SCK ↓ ⇒ Valid SIN hold time	t <sub>SLIXE</sub>	SIN0 to SIN4, SIN3_1, SIN4_1		20	-	ns	
SCK fall time	t <sub>F</sub>	SCK0 to SCK4, SCK3_1, SCK4_1		-	5	ns	
SCK rise time	t <sub>R</sub>	SCK0 to SCK4, SCK3_1, SCK4_1		-	5	ns	

- Notes:
- This is the AC characteristic in CLK synchronized mode.
  - C<sub>L</sub> is the load capacitance applied to pins during testing.
  - The maximum baud rate is limited by the internal operation clock used and other parameters. See Hardware Manual for details.

# MB91580L Series

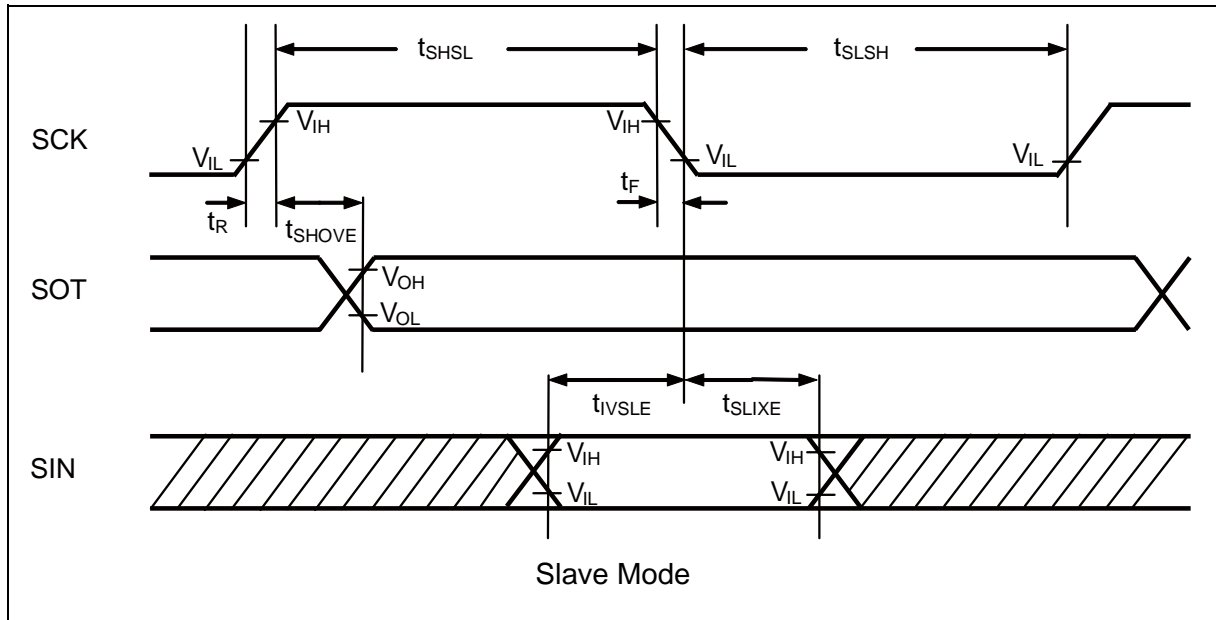
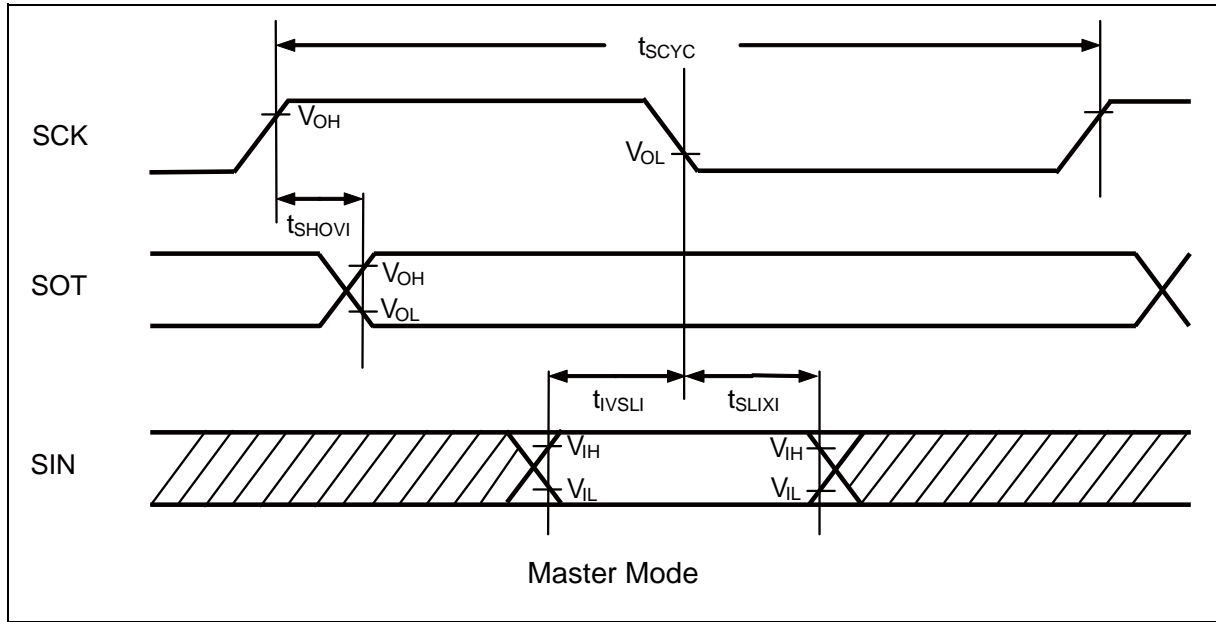

(4-1-3) SPI compatible (SCR:SPI=1) and serial clock output signal detect level "H"(SMR:SCINV=0)

(T<sub>A</sub>: Recommended operating conditions, V<sub>CC</sub>=5.0V±10% , V<sub>SS</sub>=AV<sub>SS</sub>=0.0V)

Parameter	Symbol	Pin name	Conditions	Value		Unit	Remarks
				Min	Max		
Serial clock cycle time	t <sub>SCYC</sub>	SCK0 to SCK4, SCK3_1,SCK4_1	Master mode C <sub>L</sub> =50pF	4t <sub>CPP</sub>	-	ns	
SCK ↑ ⇒ SOT delay time	t <sub>SHOVI</sub>	SCK0 to SCK4, SCK3_1,SCK4_1, SOT0 to SOT4, SOT3_1,SOT4_1		-30	+30	ns	
Valid SIN ⇒ SCK ↓ setup time	t <sub>IVSLI</sub>	SCK0 to SCK4, SCK3_1, SCK4_1,		30	-	ns	
SCK ↓ ⇒ Valid SIN hold time	t <sub>SLIXI</sub>	SIN0 to SIN4, SIN3_1, SIN4_1		0	-	ns	
SOT ⇒ SCK ↓ delay time	t <sub>SOVLI</sub>	SCK0 to SCK4, SCK3_1,SCK4_1, SOT0 to SOT4, SOT3_1,SOT4_1		2t <sub>CPP</sub> -30	-	ns	
Serial clock "H" pulse width	t <sub>SHSL</sub>	SCK0 to SCK4, SCK3_1,SCK4_1	Slave mode C <sub>L</sub> =50pF	t <sub>CPP</sub> +10	-	ns	
Serial clock "L" pulse width	t <sub>SLSH</sub>			2t <sub>CPP</sub> -10	-	ns	
SCK ↑ ⇒ SOT delay time	t <sub>SHOVE</sub>	SCK0 to SCK4, SCK3_1,SCK4_1, SOT0 to SOT4, SOT3_1,SOT4_1		-	30	ns	
Valid SIN ⇒ SCK ↓ setup time	t <sub>IVSLE</sub>	SCK0 to SCK4, SCK3_1, SCK4_1,		10	-	ns	
SCK ↓ ⇒ Valid SIN hold time	t <sub>SLIXE</sub>	SIN0 to SIN4, SIN3_1, SIN4_1		20	-	ns	
SCK fall time	t <sub>F</sub>	SCK0 to SCK4, SCK3_1, SCK4_1		-	5	ns	
SCK rise time	t <sub>R</sub>	SCK0 to SCK4, SCK3_1,SCK4_1		-	5	ns	

- Notes:
- This is the AC characteristic in CLK synchronized mode.
  - C<sub>L</sub> is the load capacitance applied to pins during testing.
  - The maximum baud rate is limited by the internal operation clock used and other parameters. See Hardware Manual for details.

# MB91580L Series

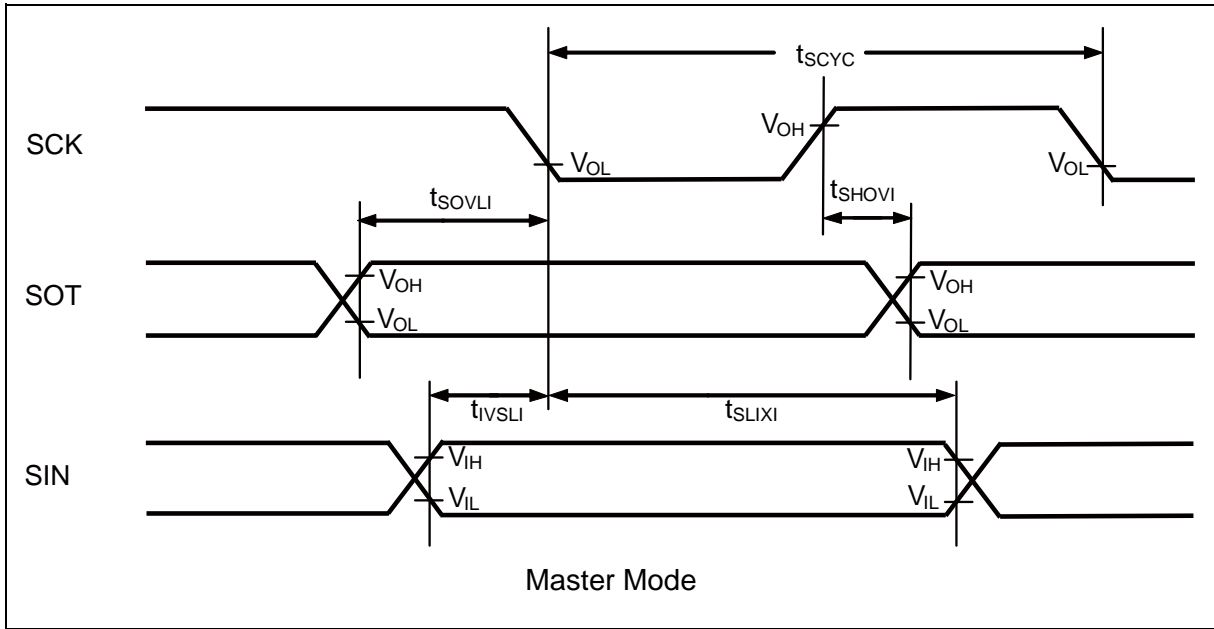

Master Mode

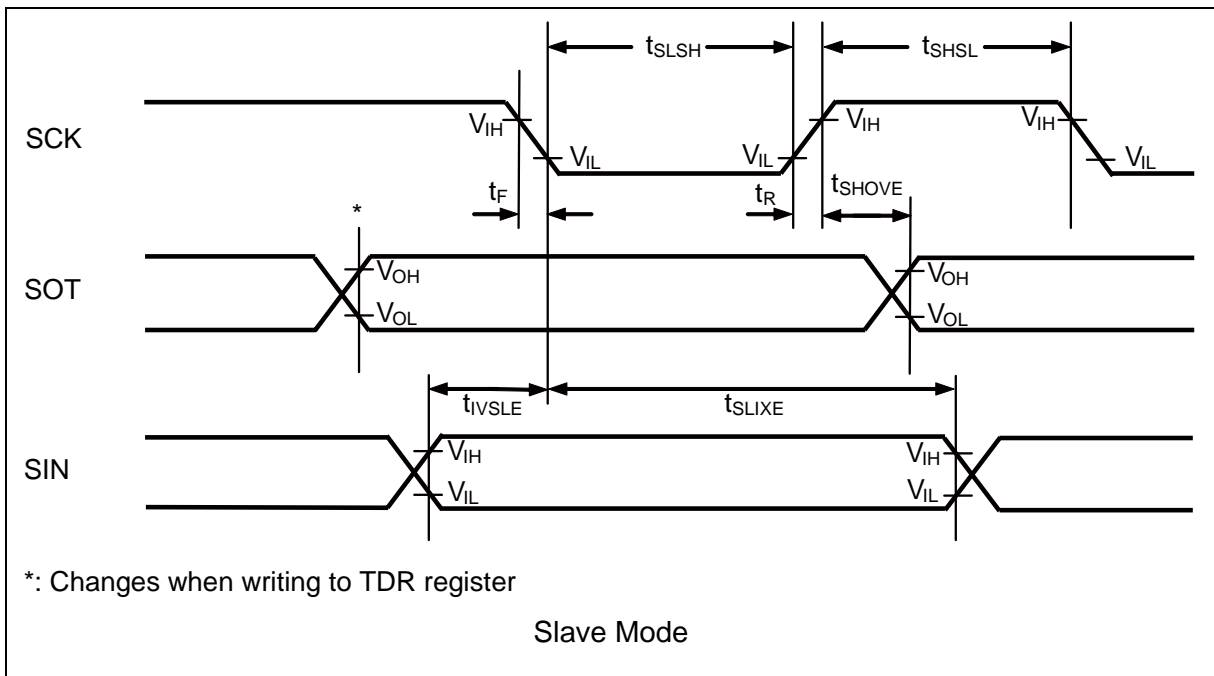

Slave Mode

(4-1-4) SPI compatible (SCR:SPI=1) and serial clock output signal detect level "L"(SMR:SCINV=1)

(T<sub>A</sub>: Recommended operating conditions, V<sub>CC</sub>=5.0V±10%, V<sub>SS</sub>=AV<sub>SS</sub>=0.0V)

Parameter	Symbol	Pin name	Conditions	Value		Unit	Remarks
				Min	Max		
Serial clock cycle time	t <sub>SCYC</sub>	SCK0 to SCK4, SCK3_1,SCK4_1	Master mode C <sub>L</sub> =50pF	4t <sub>CPP</sub>	-	ns	
SCK ↓ ⇒ SOT delay time	t <sub>SLOVI</sub>	SCK0 to SCK4, SCK3_1,SCK4_1, SOT0 to SOT4, SOT3_1,SOT4_1		-30	+30	ns	
Valid SIN ⇒ SCK ↑ setup time	t <sub>IVSHI</sub>	SCK0 to SCK4, SCK3_1, SCK4_1,		30	-	ns	
SCK ↑ ⇒ Valid SIN hold time	t <sub>SHIXI</sub>	SIN0 to SIN4, SIN3_1, SIN4_1		0	-	ns	
SOT ⇒ SCK ↑ delay time	t <sub>SOVHI</sub>	SCK0 to SCK4, SCK3_1,SCK4_1, SOT0 to SOT4, SOT3_1,SOT4_1		2t <sub>CPP</sub> -30	-	ns	
Serial clock "H" pulse width	t <sub>SHSL</sub>	SCK0 to SCK4, SCK3_1,SCK4_1, SOT0 to SOT4, SOT3_1,SOT4_1	Slave mode C <sub>L</sub> =50pF	t <sub>CPP</sub> +10	-	ns	
Serial clock "L" pulse width	t <sub>SLSH</sub>			2t <sub>CPP</sub> -10	-	ns	
SCK ↓ ⇒ SOT delay time	t <sub>SLOVE</sub>	SCK0 to SCK4, SCK3_1,SCK4_1, SOT0 to SOT4, SOT3_1,SOT4_1		-	30	ns	
Valid SIN ⇒ SCK ↑ setup time	t <sub>IVSHE</sub>	SCK0 to SCK4, SCK3_1, SCK4_1,		10	-	ns	
SCK ↑ ⇒ Valid SIN hold time	t <sub>SHIXE</sub>	SIN0 to SIN4, SIN3_1, SIN4_1		20	-	ns	
SCK fall time	t <sub>F</sub>	SCK0 to SCK4, SCK3_1, SCK4_1		-	5	ns	
SCK rise time	t <sub>R</sub>	SCK0 to SCK4, SCK3_1,SCK4_1		-	5	ns	

- Notes:
- This is the AC characteristic in CLK synchronized mode.
  - C<sub>L</sub> is the load capacitance applied to pins during testing.
  - The maximum baud rate is limited by the internal operation clock used and other parameters. See Hardware Manual for details.

# MB91580L Series

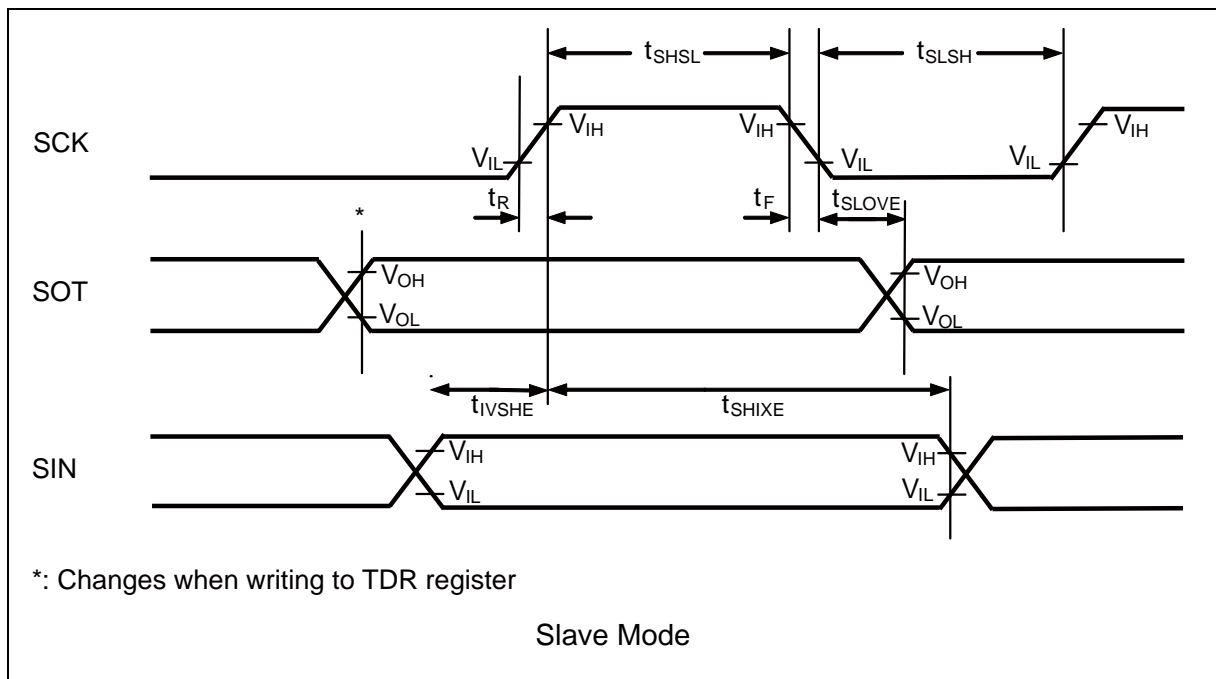
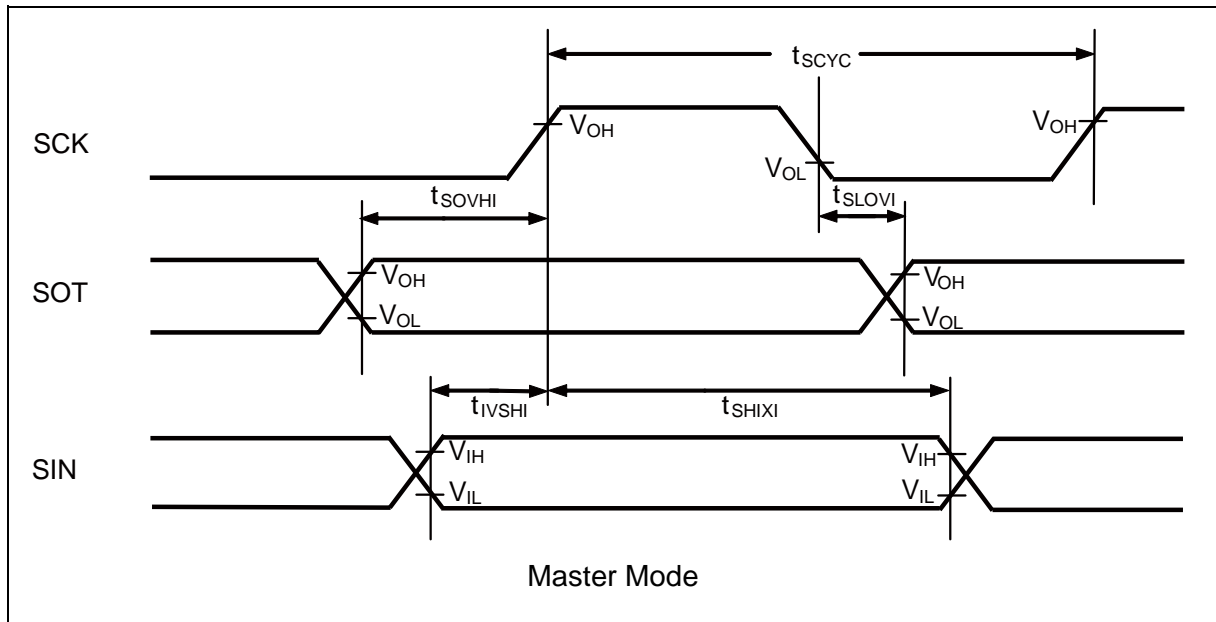



(4-1-5) When the serial chip select is used (SCSCR:CSEN=1)

- Serial clock output signal detect level "H"(SMR,SCSFR:SCINV=0)
- Serial chip select inactive level "H"(SCSCR,SCSFR:CSLVL=1)

(T<sub>A</sub>: Recommended operating conditions, V<sub>CC</sub> =5.0V±10%, V<sub>SS</sub>=AV<sub>SS</sub>=0.0V)

Parameter	Symbol	Pin name	Conditions	Value		Unit	Remarks
				Min	Max		
SCS ↓ ⇒ SCK ↓ setup time	t <sub>CSSU</sub>	SCK1 to SCK4, SCK3_1,SCK4_1, SCS1 to SCS3, SCS3_1, SCS40 to SCS43 SCS40_1 to SCS43_1	Master mode C <sub>L</sub> =50pF	-50-t <sub>CSSU</sub> <sup>*1</sup>	+0-t <sub>CSSU</sub> <sup>*1</sup>	ns	
SCK ↑ ⇒ SCS ↑ hold time	t <sub>CSHI</sub>	SCS1 to SCS3, SCS3_1, SCS40 to SCS43 SCS40_1 to SCS43_1		+0+t <sub>CSHD</sub> <sup>*2</sup>	+50+t <sub>CSHD</sub> <sup>*2</sup>	ns	
SCS deselect time	t <sub>CSDI</sub>	SCS1 to SCS3, SCS3_1, SCS40 to SCS43 SCS40_1 to SCS43_1		-50+t <sub>CSDS</sub> <sup>*3</sup>	+50+t <sub>CSDS</sub> <sup>*3</sup>	ns	
SCS ↓ ⇒ SCK ↓ setup time	t <sub>CSSSE</sub>	SCK1 to SCK4, SCK3_1,SCK4_1, SCS1 to SCS3, SCS3_1, SCS40 to SCS43 SCS40_1 to SCS43_1	Slave mode C <sub>L</sub> =50pF	3t <sub>CPP</sub> +30	-	ns	
SCK ↑ ⇒ SCS ↑ hold time	t <sub>CSHE</sub>	SCS1 to SCS3, SCS3_1, SCS40 to SCS43 SCS40_1 to SCS43_1		0	-	ns	
SCS deselect time	t <sub>CSEDE</sub>	SCS1 to SCS3, SCS3_1, SCS40 to SCS43 SCS40_1 to SCS43_1		3t <sub>CPP</sub> +30	-	ns	
SCS ↓ ⇒ SOT delay time	t <sub>DSE</sub>	SCS1 to SCS3, SCS3_1, SCS40 to SCS43 SCS40_1 to SCS43_1,		-	40	ns	
SCS ↑ ⇒ SOT delay time	t <sub>DEE</sub>	SOT0 to SOT4, SOT3_1,SOT4_1		0	-	ns	
SCK ↓ ⇒ SCS ↓ clock switch time	t <sub>SCC</sub>	SCK1 to SCK4, SCK3_1,SCK4_1, SCS1 to SCS3, SCS3_1, SCS40 to SCS43 SCS40_1 to SCS43_1		Master mode round operation C <sub>L</sub> =50pF	3t <sub>CPP</sub> +0	3t <sub>CPP</sub> +50	ns

\*1: t<sub>CSSU</sub> = SCSTR:CSSU7-0 × Serial chip select timing operation clock

\*2: t<sub>CSHD</sub> = SCSTR:CSHD7-0 × Serial chip select timing operation clock

\*3: t<sub>CSDS</sub> = SCSTR:CSDS15-0 × Serial chip select timing operation clock

For details of \*1, \*2 and \*3 above, see Hardware Manual.

- Notes:
- This is the AC characteristic in CLK synchronized mode.
  - C<sub>L</sub> is the load capacitance applied to pins during testing.
  - The maximum baud rate is limited by the internal operation clock used and other parameters. See Hardware Manual for details.

# MB91580L Series

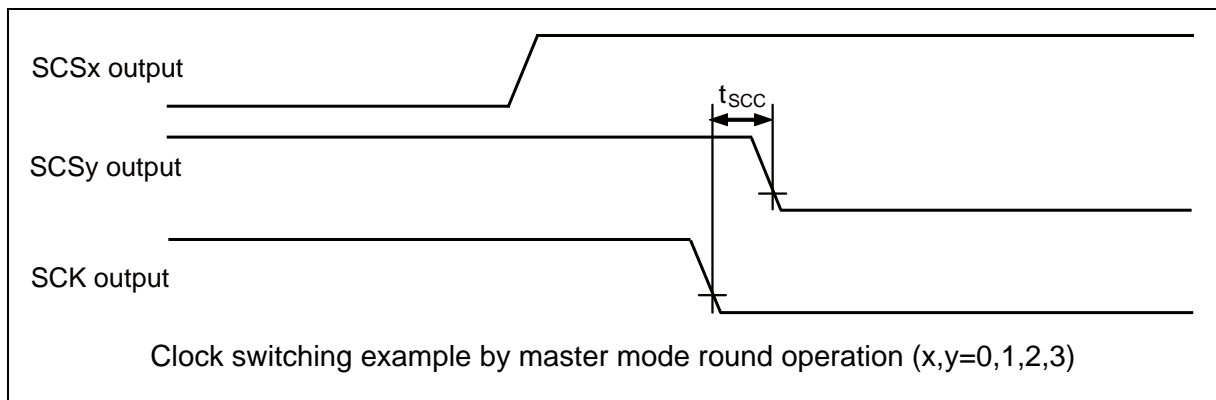
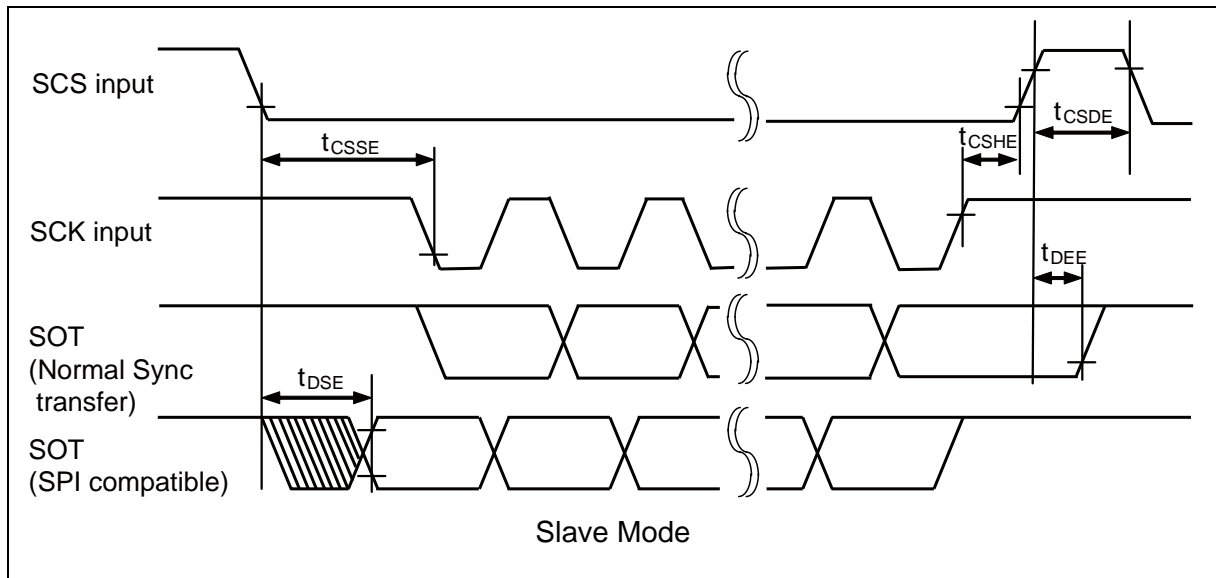
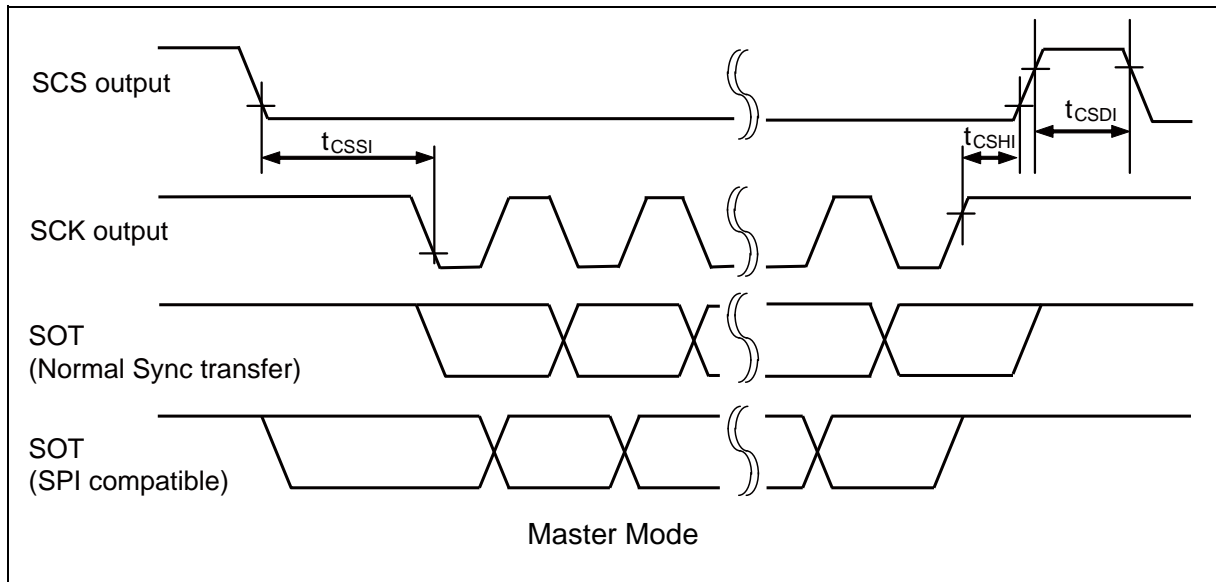

(4-1-6) When the serial chip select is used (SCSCR:CSEN=1)

- Serial clock output signal detect level "L"(SMR,SCSFR:SCINV=1)
- Serial chip select inactive level "H"(SCSCR,SCSFR:CSLVL=1)

(T<sub>A</sub>: Recommended operating conditions, V<sub>CC</sub> =5.0V±10%, V<sub>SS</sub>=AV<sub>SS</sub>=0.0V)

Parameter	Symbol	Pin name	Conditions	Value		Unit	Remarks
				Min	Max		
SCS ↓ ⇒ SCK ↑ setup time	t <sub>CSSU</sub>	SCK1 to SCK4, SCK3_1,SCK4_1, SCS1 to SCS3, SCS3_1, SCS40 to SCS43 SCS40_1 to SCS43_1	Master mode C <sub>L</sub> =50pF	-50-t <sub>CSSU</sub> <sup>*1</sup>	+0-t <sub>CSSU</sub> <sup>*1</sup>	ns	
SCK ↓ ⇒ SCS ↑ hold time	t <sub>CSHI</sub>	SCS1 to SCS3, SCS3_1, SCS40 to SCS43 SCS40_1 to SCS43_1		+0+t <sub>CSHD</sub> <sup>*2</sup>	+50+t <sub>CSHD</sub> <sup>*2</sup>	ns	
SCS deselect time	t <sub>CSDI</sub>	SCS1 to SCS3, SCS3_1, SCS40 to SCS43 SCS40_1 to SCS43_1		-50+t <sub>CSDS</sub> <sup>*3</sup>	+50+t <sub>CSDS</sub> <sup>*3</sup>	ns	
SCS ↓ ⇒ SCK ↑ setup time	t <sub>CSSU</sub>	SCK1 to SCK4, SCK3_1,SCK4_1, SCS1 to SCS3, SCS3_1, SCS40 to SCS43 SCS40_1 to SCS43_1	Slave mode C <sub>L</sub> =50pF	3t <sub>CPP</sub> +30	-	ns	
SCK ↓ ⇒ SCS ↑ hold time	t <sub>CSHE</sub>	SCS1 to SCS3, SCS3_1, SCS40 to SCS43 SCS40_1 to SCS43_1		0	-	ns	
SCS deselect time	t <sub>CSDU</sub>	SCS1 to SCS3, SCS3_1, SCS40 to SCS43 SCS40_1 to SCS43_1		3t <sub>CPP</sub> +30	-	ns	
SCS ↓ ⇒ SOT delay time	t <sub>DSE</sub>	SCS1 to SCS3, SCS3_1, SCS40 to SCS43 SCS40_1 to SCS43_1,		-	40	ns	
SCS ↑ ⇒ SOT delay time	t <sub>DEE</sub>	SOT0 to SOT4, SOT3_1,SOT4_1		0	-	ns	
SCK ↑ ⇒ SCS ↓ clock switch time	t <sub>SCC</sub>	SCK1 to SCK4, SCK3_1,SCK4_1, SCS1 to SCS3, SCS3_1, SCS40 to SCS43 SCS40_1 to SCS43_1		Master mode round operation C <sub>L</sub> =50pF	3t <sub>CPP</sub> +0	3t <sub>CPP</sub> +50	ns

\*1: t<sub>CSSU</sub> = SCSTR:CSSU7-0 × Serial chip select timing operation clock

\*2: t<sub>CSHD</sub> = SCSTR:CSHD7-0 × Serial chip select timing operation clock

\*3: t<sub>CSDS</sub> = SCSTR:CSDS15-0 × Serial chip select timing operation clock

For details of \*1, \*2 and \*3 above, see Hardware Manual.

- Notes:
- This is the AC characteristic in CLK synchronized mode.
  - C<sub>L</sub> is the load capacitance applied to pins during testing.
  - The maximum baud rate is limited by the internal operation clock used and other parameters. See Hardware Manual for details.

# MB91580L Series

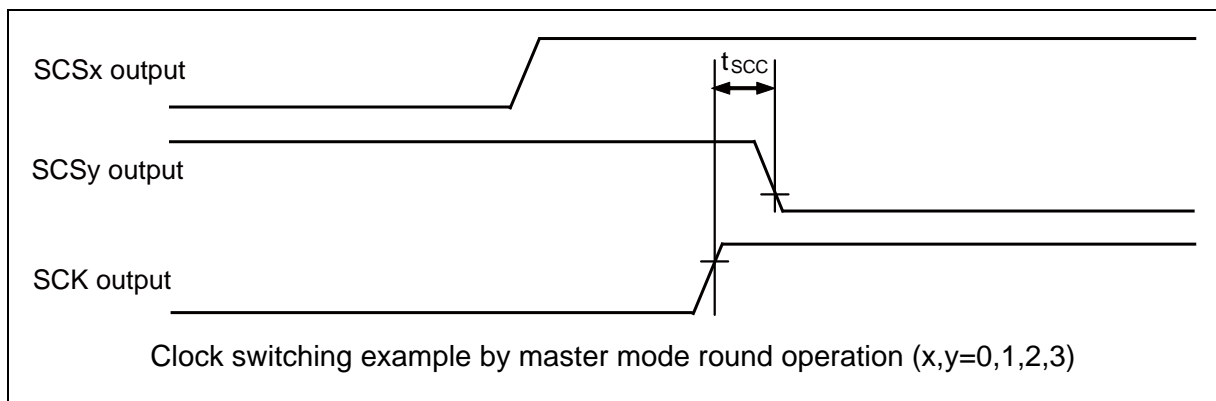
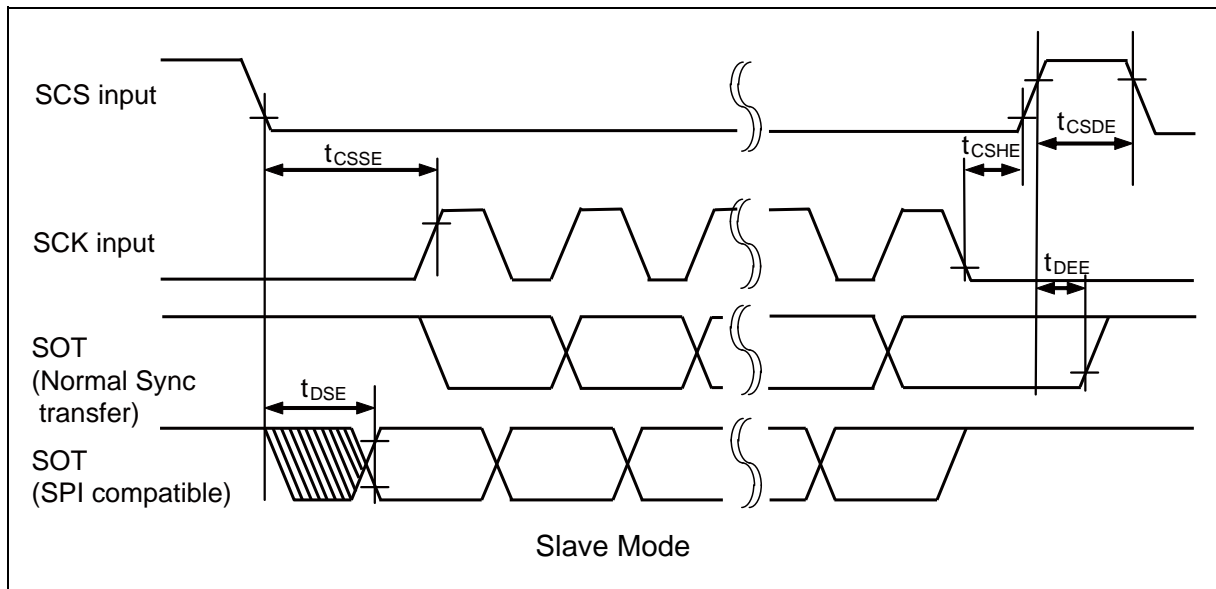
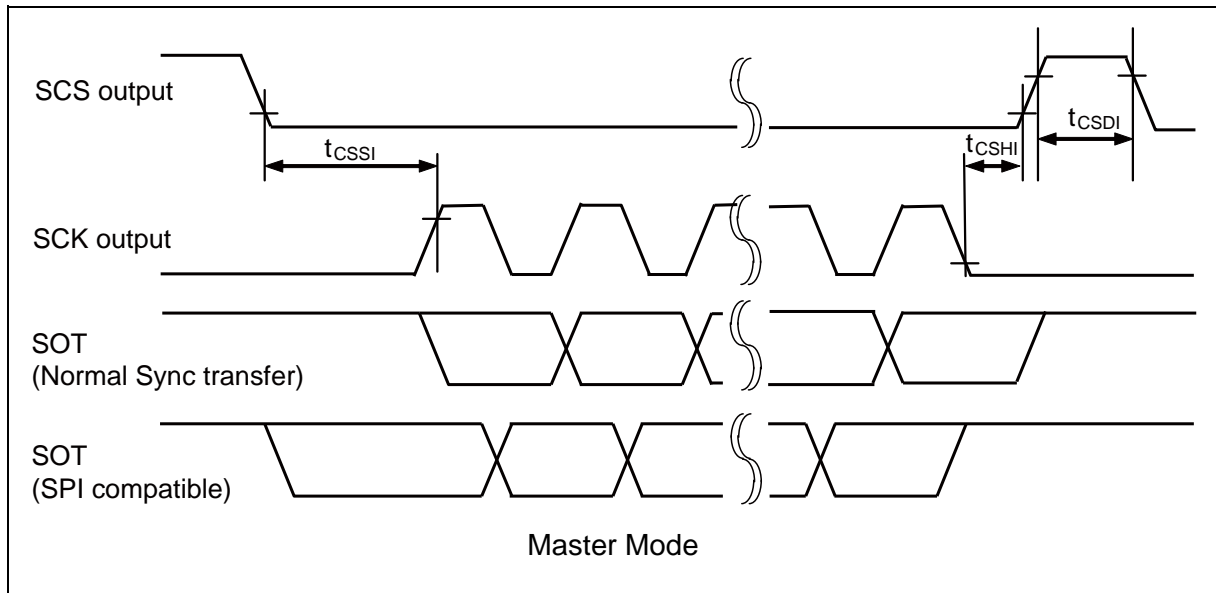

(4-1-7) When the serial chip select is used (SCSCR:CSEN=1)

- Serial clock output signal detect level "H"(SMR,SCSFR:SCINV=0)
- Serial chip select inactive level "L"(SCSCR,SCSFR:CSLVL=0)

(T<sub>A</sub>: Recommended operating conditions, V<sub>CC</sub> =5.0V±10%, V<sub>SS</sub>=AV<sub>SS</sub>=0.0V)

Parameter	Symbol	Pin name	Conditions	Value		Unit	Remarks
				Min	Max		
SCS ↑ ⇒ SCK ↓ setup time	t <sub>CSSU</sub>	SCK1 to SCK4, SCK3_1,SCK4_1, SCS0 to SCS3, SCS3_1, SCS40 to SCS43 SCS40_1 to SCS43_1	Master mode C <sub>L</sub> =50pF	-50-t <sub>CSSU</sub> <sup>*1</sup>	+0-t <sub>CSSU</sub> <sup>*1</sup>	ns	
SCK ↑ ⇒ SCS ↓ hold time	t <sub>CSHI</sub>	SCS0 to SCS3, SCS3_1, SCS40 to SCS43 SCS40_1 to SCS43_1		+0+t <sub>CSHD</sub> <sup>*2</sup>	+50+t <sub>CSHD</sub> <sup>*2</sup>	ns	
SCS deselect time	t <sub>CSDI</sub>	SCS0 to SCS3, SCS3_1, SCS40 to SCS43 SCS40_1 to SCS43_1		-50+t <sub>CSDS</sub> <sup>*3</sup>	+50+t <sub>CSDS</sub> <sup>*3</sup>	ns	
SCS ↑ ⇒ SCK ↓ setup time	t <sub>CSSE</sub>	SCK1 to SCK4, SCK3_1,SCK4_1, SCS0 to SCS3, SCS3_1, SCS40 to SCS43 SCS40_1 to SCS43_1	Slave mode C <sub>L</sub> =50pF	3t <sub>CPP</sub> +30	-	ns	
SCK ↑ ⇒ SCS ↓ hold time	t <sub>CSHE</sub>	SCS0 to SCS3, SCS3_1, SCS40 to SCS43 SCS40_1 to SCS43_1		0	-	ns	
SCS deselect time	t <sub>CSDE</sub>	SCS0 to SCS3, SCS3_1, SCS40 to SCS43, SCS40_1 to SCS43_1		3t <sub>CPP</sub> +30	-	ns	
SCS ↑ ⇒ SOT delay time	t <sub>DSE</sub>	SCS0 to SCS3, SCS3_1, SCS40 to SCS43 SCS40_1 to SCS43_1,		-	40	ns	
SCS ↓ ⇒ SOT delay time	t <sub>DEE</sub>	SOT0 to SOT4, SOT3_1,SOT4_1		0	-	ns	
SCK ↓ ⇒ SCS ↑ clock switch time	t <sub>SCC</sub>	SCK1 to SCK4, SCK3_1,SCK4_1, SCS0 to SCS3, SCS3_1, SCS40 to SCS43 SCS40_1 to SCS43_1		Master mode round operation C <sub>L</sub> =50pF	3t <sub>CPP</sub> +0	3t <sub>CPP</sub> +50	

\*1: t<sub>CSSU</sub> = SCSTR:CSSU7-0 × Serial chip select timing operation clock

\*2: t<sub>CSHD</sub> = SCSTR:CSHD7-0 × Serial chip select timing operation clock

\*3: t<sub>CSDS</sub> = SCSTR:CSDS15-0 × Serial chip select timing operation clock

For details of \*1, \*2 and \*3 above, see Hardware Manual.

- Notes:
- This is the AC characteristic in CLK synchronized mode.
  - C<sub>L</sub> is the load capacitance applied to pins during testing.
  - The maximum baud rate is limited by the internal operation clock used and other parameters.  
See Hardware Manual for details.

# MB91580L Series

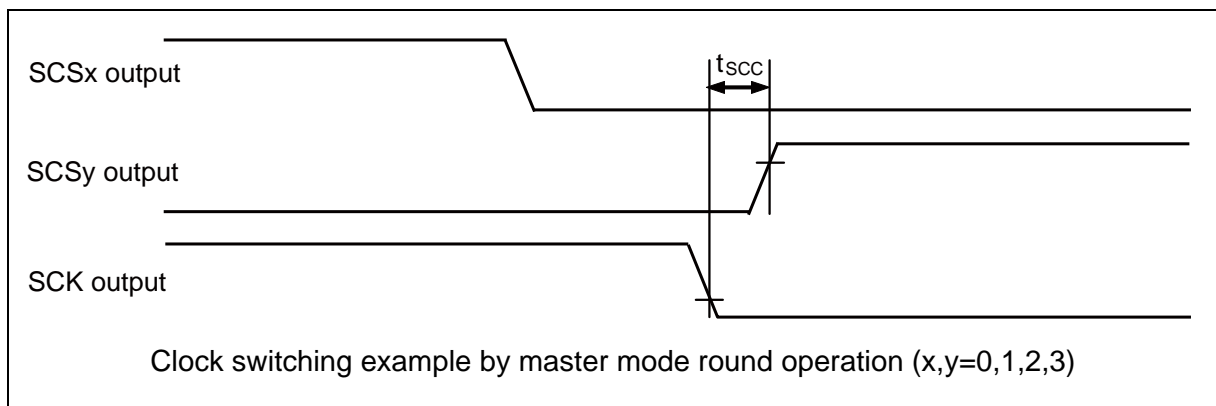
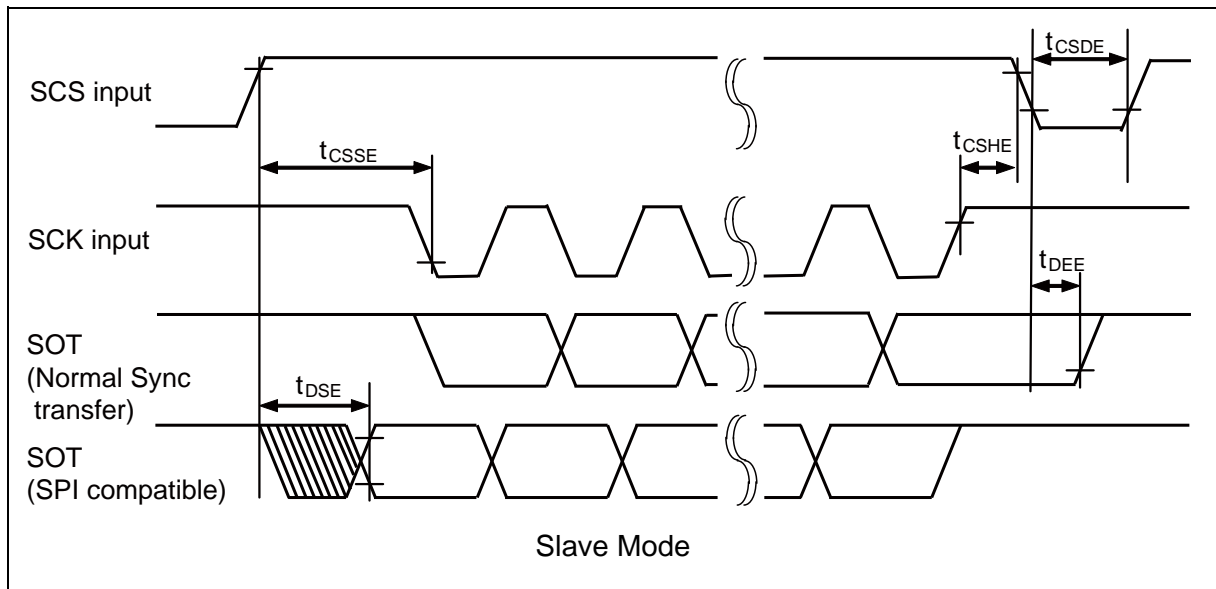
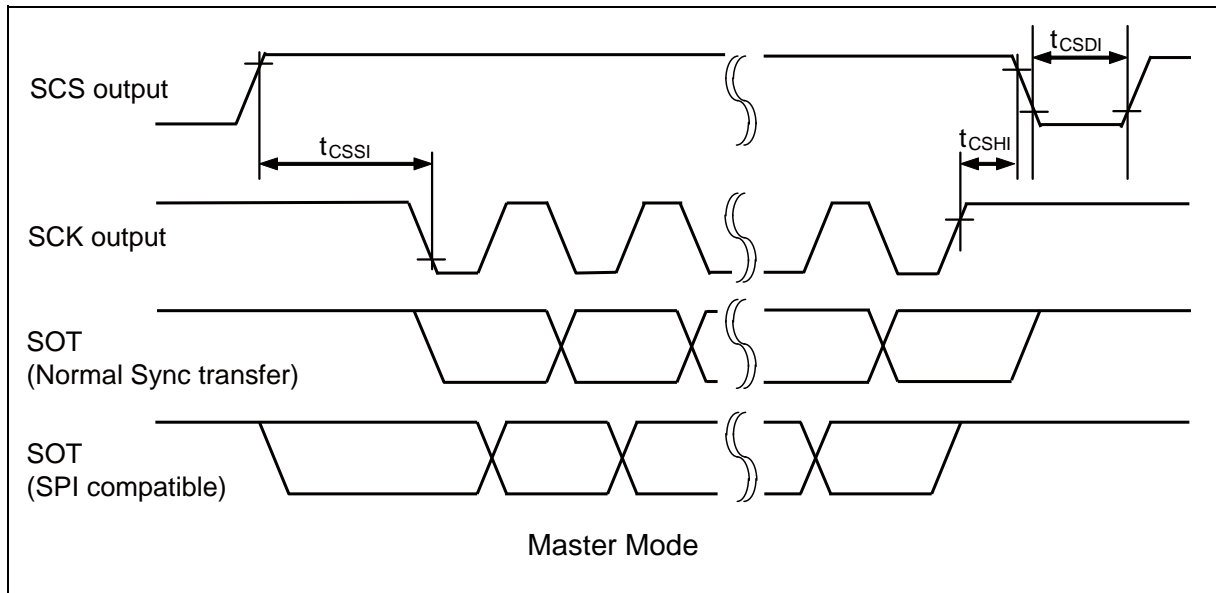

(4-1-8) When the serial chip select is used (SCSCR:CSEN=1)

- Serial clock output signal detect level "L"(SMR,SCSFR:SCINV=1)
- Serial chip select inactive level "L"(SCSCR,SCSFR:CSLVL=0)

(T<sub>A</sub>: Recommended operating conditions, V<sub>CC</sub> =5.0V±10%, V<sub>SS</sub>=AV<sub>SS</sub>=0.0V)

Parameter	Symbol	Pin name	Conditions	Value		Unit	Remarks
				Min	Max		
SCS ↑ ⇒ SCK ↑ setup time	t <sub>CSSU</sub>	SCK1 to SCK4, SCK3_1,SCK4_1, SCS1 to SCS3, SCS3_1, SCS40 to SCS43 SCS40_1 to SCS43_1	Master mode C <sub>L</sub> =50pF	-50-t <sub>CSSU</sub> <sup>*1</sup>	+0-t <sub>CSSU</sub> <sup>*1</sup>	ns	
SCK ↓ ⇒ SCS ↓ hold time	t <sub>CSHD</sub>	SCS1 to SCS3, SCS3_1, SCS40 to SCS43 SCS40_1 to SCS43_1		+0+t <sub>CSHD</sub> <sup>*2</sup>	+50+t <sub>CSHD</sub> <sup>*2</sup>	ns	
SCS deselect time	t <sub>CSDI</sub>	SCS1 to SCS3, SCS3_1, SCS40 to SCS43 SCS40_1 to SCS43_1		-50+t <sub>CSDS</sub> <sup>*3</sup>	+50+t <sub>CSDS</sub> <sup>*3</sup>	ns	
SCS ↑ ⇒ SCK ↑ setup time	t <sub>CSSU</sub>	SCK1 to SCK4, SCK3_1,SCK4_1, SCS1 to SCS3, SCS3_1, SCS40 to SCS43 SCS40_1 to SCS43_1	Slave mode C <sub>L</sub> =50pF	3t <sub>CPP</sub> +30	-	ns	
SCK ↓ ⇒ SCS ↓ hold time	t <sub>CSHE</sub>	SCS1 to SCS3, SCS3_1, SCS40 to SCS43 SCS40_1 to SCS43_1		0	-	ns	
SCS deselect time	t <sub>CSDI</sub>	SCS1 to SCS3, SCS3_1, SCS40 to SCS43 SCS40_1 to SCS43_1		3t <sub>CPP</sub> +30	-	ns	
SCS ↑ ⇒ SOT delay time	t <sub>DSE</sub>	SCS1 to SCS3, SCS3_1, SCS40 to SCS43 SCS40_1 to SCS43_1,		-	40	ns	
SCS ↓ ⇒ SOT delay time	t <sub>DEE</sub>	SOT0 to SOT4, SOT3_1,SOT4_1		0	-	ns	
SCK ↑ ⇒ SCS ↑ clock switch time	t <sub>SCC</sub>	SCK1 to SCK4, SCK3_1,SCK4_1, SCS1 to SCS3, SCS3_1, SCS40 to SCS43 SCS40_1 to SCS43_1		Master mode round operation C <sub>L</sub> =50pF	3t <sub>CPP</sub> +0	3t <sub>CPP</sub> +50	ns

\*1: t<sub>CSSU</sub> = SCSTR:CSSU7-0 × Serial chip select timing operation clock

\*2: t<sub>CSHD</sub> = SCSTR:CSHD7-0 × Serial chip select timing operation clock

\*3: t<sub>CSDS</sub> = SCSTR:CSDS15-0 × Serial chip select timing operation clock

For details of \*1, \*2 and \*3 above, see Hardware Manual.

- Notes:
- This is the AC characteristic in CLK synchronized mode.
  - C<sub>L</sub> is the load capacitance applied to pins during testing.
  - The maximum baud rate is limited by the internal operation clock used and other parameters. See Hardware Manual for details.

# MB91580L Series

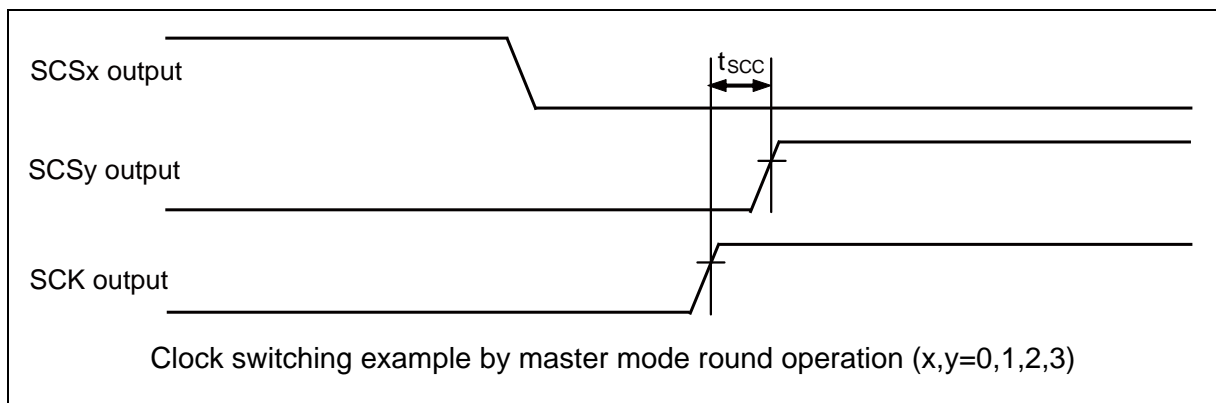
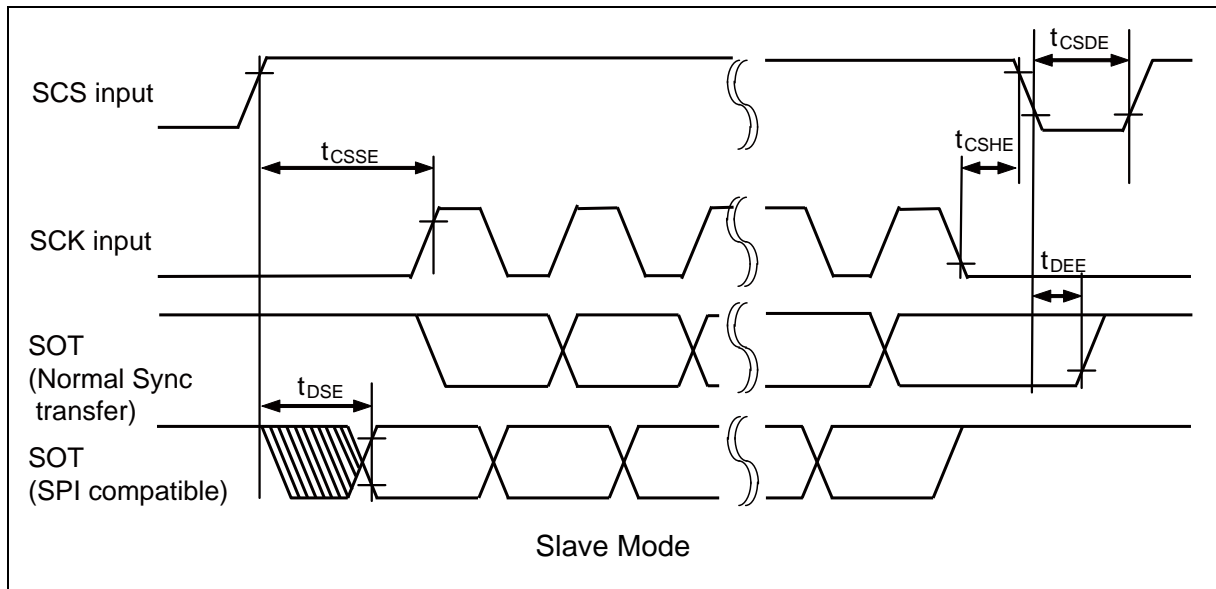
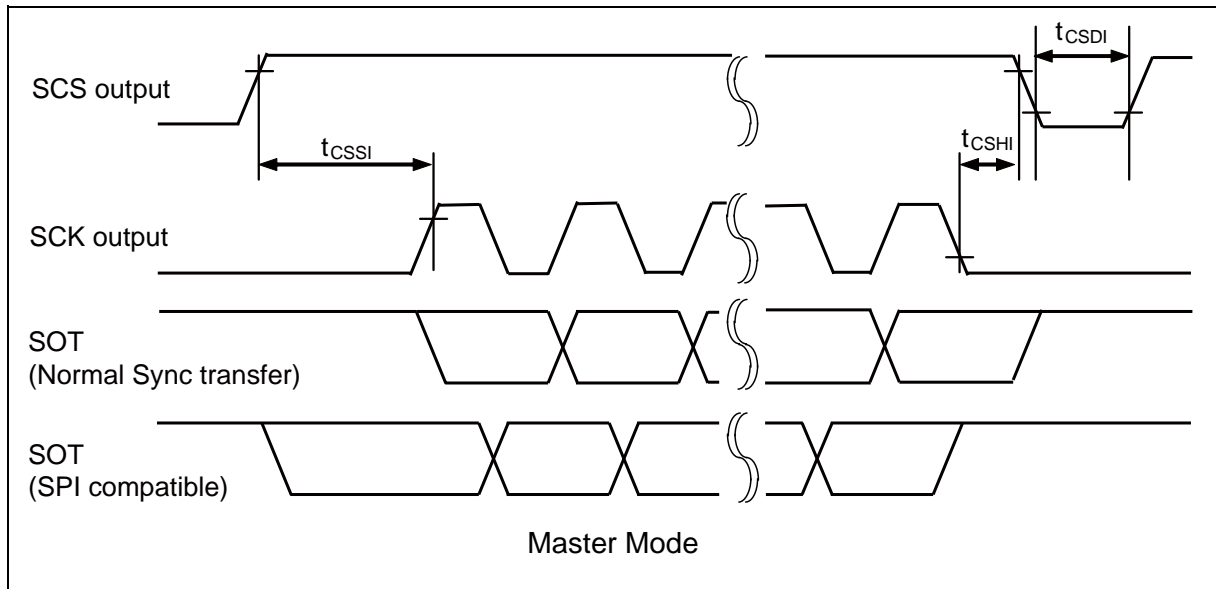



## (4-2) UART (Async Serial Interface) timing (SMR:MD2-0="000"b, "001"b)

### (4-2-1) When the external clock is selected (BGR:EXT=1)

(T<sub>A</sub>: Recommended operating conditions, V<sub>CC</sub> =5.0V±10%, V<sub>SS</sub>=AV<sub>SS</sub>=0.0V)

Parameter	Symbol	Pin name	Conditions	Value		Unit	Remarks
				Min	Max		
Serial clock "L" pulse width	t <sub>SLSH</sub>	SCK0 to SCK4, SCK3_1,SCK4_1	C <sub>L</sub> =50pF	t <sub>CPP</sub> +10	-	ns	
Serial clock "H" pulse width	t <sub>SHSL</sub>			t <sub>CPP</sub> +10	-	ns	
SCK fall time	t <sub>F</sub>			-	5	ns	
SCK rise time	t <sub>R</sub>			-	5	ns	

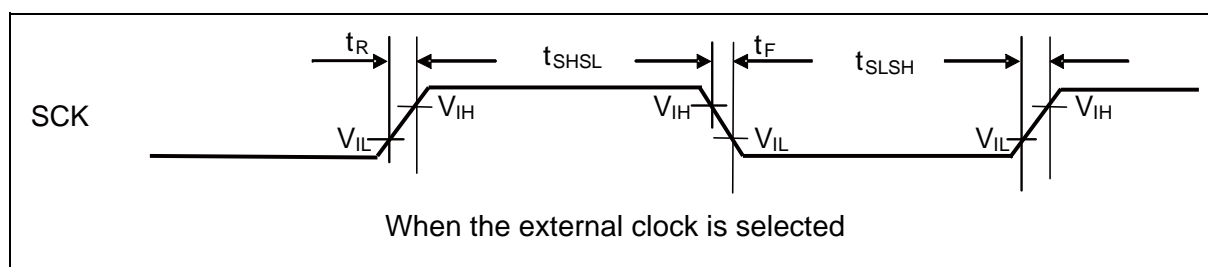

## (4-3) LIN interface (v2.1) (LIN Communication Control Interface (v2.1)) timing (SMR:MD2-0="011"b)

### (4-3-1) When the external clock is selected (BGR:EXT=1)

(T<sub>A</sub>: Recommended operating conditions, V<sub>CC</sub> =5.0V±10%, V<sub>SS</sub>=AV<sub>SS</sub>=0.0V)

Parameter	Symbol	Pin name	Conditions	Value		Unit	Remarks
				Min	Max		
Serial clock "L" pulse width	t <sub>SLSH</sub>	SCK0 to SCK4, SCK3_1,SCK4_1	C <sub>L</sub> =50pF	t <sub>CPP</sub> +10	-	ns	
Serial clock "H" pulse width	t <sub>SHSL</sub>			t <sub>CPP</sub> +10	-	ns	
SCK fall time	t <sub>F</sub>			-	5	ns	
SCK rise time	t <sub>R</sub>			-	5	ns	

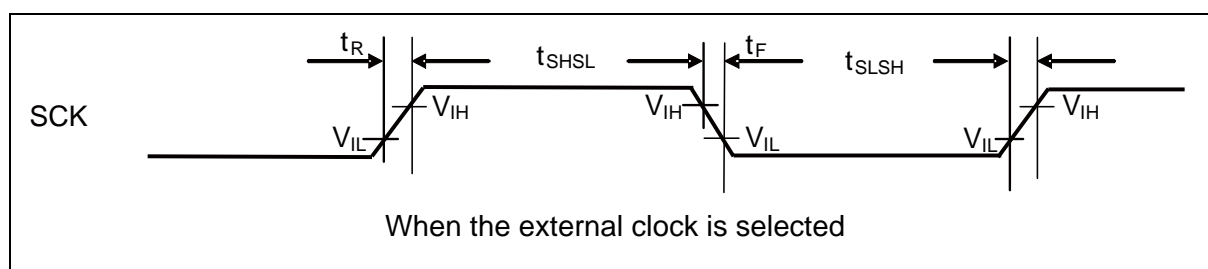

# MB91580L Series

## (4-4) I<sup>2</sup>C timing (SMR:MD2-0="100"b)

(T<sub>A</sub>: Recommended operating conditions, V<sub>CC</sub>=5.0V±10%, V<sub>SS</sub>=AV<sub>SS</sub>=0.0V)

Parameter	Symbol	Pin name	Conditions	Standard mode		High-speed mode <sup>*3</sup>		Unit	Remarks
				Min	Max	Min	Max		
SCL clock frequency	f <sub>SCL</sub>	SCK0,SCK1, SCK3,SCK4, SCK3_1,SCK4_1 (SCL)	C <sub>L</sub> =50pF R=(V <sub>P</sub> /I <sub>OL</sub> ) <sup>*1</sup>	0	100	0	400	kHz	
"Repeat START condition" hold time SDA ↓ → SCL ↓	t <sub>HDSTA</sub>	SCK0,SCK1, SCK3,SCK4, SCK3_1,SCK4_1 (SCL) SOT0,SOT1, SOT3,SOT4, SOT3_1,SOT4_1 (SDA)		4.0	-	0.6	-	μs	
"L" width for SCL clock	t <sub>LOW</sub>	SCK0,SCK1, SCK3,SCK4, SCK3_1,SCK4_1 (SCL)		4.7	-	1.3	-	μs	
"H" width for SCL clock	t <sub>HIGH</sub>	SCK0,SCK1, SCK3,SCK4, SCK3_1,SCK4_1 (SCL)		4.0	-	0.6	-	μs	
"Repeat START condition" setup time SCL ↑ → SDA ↓	t <sub>SUSTA</sub>	SCK0,SCK1, SCK3,SCK4, SCK3_1,SCK4_1 (SCL) SOT0,SOT1, SOT3,SOT4, SOT3_1,SOT4_1 (SDA)		4.7	-	0.6	-	μs	
Data hold time SCL ↓ → SDA ↓ ↑	t <sub>HDDAT</sub>	SCK0,SCK1, SCK3,SCK4, SCK3_1,SCK4_1 (SCL) SOT0,SOT1, SOT3,SOT4, SOT3_1,SOT4_1 (SDA)		0	3.45 <sup>*2</sup>	0	0.90 <sup>*3</sup>	μs	
Data setup time SDA ↓ ↑ → SCL ↑	t <sub>SUDAT</sub>	SCK0,SCK1, SCK3,SCK4, SCK3_1,SCK4_1 (SCL) SOT0,SOT1, SOT3,SOT4, SOT3_1,SOT4_1 (SDA)		250	-	100	-	ns	
"STOP condition" setup time SCL ↑ → SDA ↑	t <sub>SUSTO</sub>	SCK0,SCK1, SCK3,SCK4, SCK3_1,SCK4_1 (SCL) SOT0,SOT1, SOT3,SOT4, SOT3_1,SOT4_1 (SDA)		4.0	-	0.6	-	μs	
Bus free time between "STOP condition" and "START condition"	t <sub>BUF</sub>	-		4.7	-	1.3	-	μs	
Noise filter	t <sub>SP</sub>	-		2t <sub>CPP</sub> <sup>*4</sup>	-	2t <sub>CPP</sub> <sup>*4</sup>	-	ns	

\*1: R and C represent the pull-up resistance and load capacitance of the SCL and SDA output lines, respectively.

V<sub>P</sub> shows that the power supply voltage of the pull-up resistor and I<sub>OL</sub> shows the V<sub>OL</sub> guarantee current.

\*2: The maximum t<sub>HDDAT</sub> only has to be met if the device does not extend the "L" width (t<sub>LOW</sub>) of the SCL signal.

\*3: A high-speed mode I<sup>2</sup>C bus device can be used on a standard mode I<sup>2</sup>C bus system as long as the device satisfies the requirement of "t<sub>SUDAT</sub> ≥ 250 ns".

\*4: t<sub>CPP</sub> is the peripheral clock cycle time. Adjust the clock of the peripheral bus to 8MHz or more when use I<sup>2</sup>C.

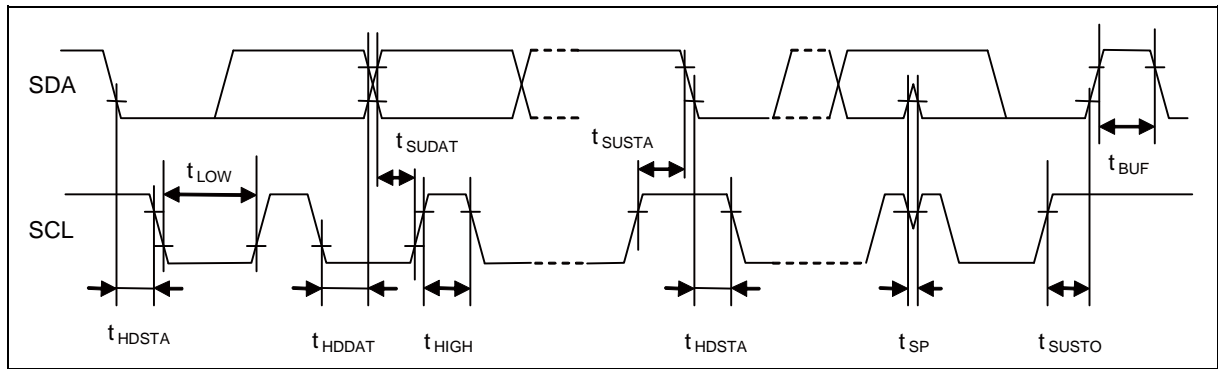

# MB91580L Series

## (5) Timer input timing

(T<sub>A</sub>: Recommended operating conditions, V<sub>CC</sub> = 5.0V±10%, V<sub>SS</sub> = AV<sub>SS</sub> = 0.0V)

Parameter	Symbol	Pin name	Conditions	Value		Unit	Remarks
				Min	Max		
Input pulse width	t <sub>TIWH</sub> , t <sub>TIWL</sub>	TIN0 to TIN3, IN0 to IN7, FRCK0 to FRCK5, TIOA0, TIOA1, TIOB0, TIOB1	-	4t <sub>CPP</sub>	-	ns	
		AIN0, AIN1, BIN0, BIN1, ZIN0, ZIN1	-	2t <sub>CPP</sub>	-	ns	

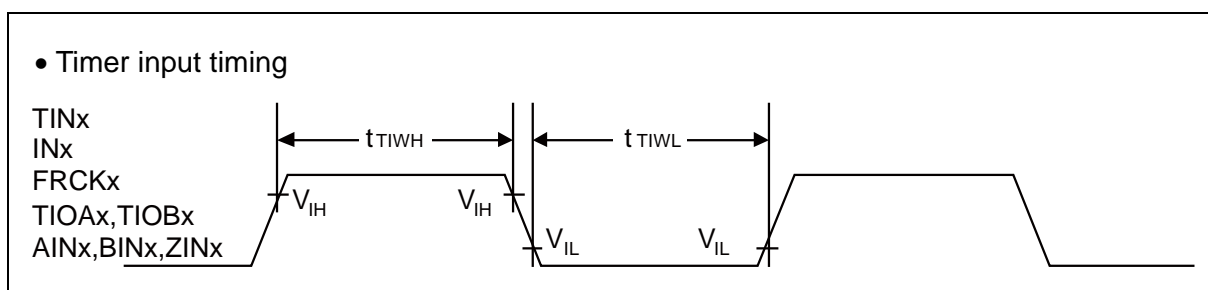

## (6) Trigger input timing

(T<sub>A</sub>: Recommended operating conditions, V<sub>CC</sub> = 5.0V±10% V<sub>SS</sub> = AV<sub>SS</sub> = 0.0V)

Parameter	Symbol	Pin name	Conditions	Value		Unit	Remarks
				Min	Max		
Input pulse width	t <sub>TRGH</sub> , t <sub>TRGL</sub>	INT0 to INT7, ADTG0 to ADTG2, RX0 to RX2, TRG0 to TRG5, DTTI0, DTTI1	-	5t <sub>CPP</sub>	-	ns	
				1	-	μs	At Stop mode

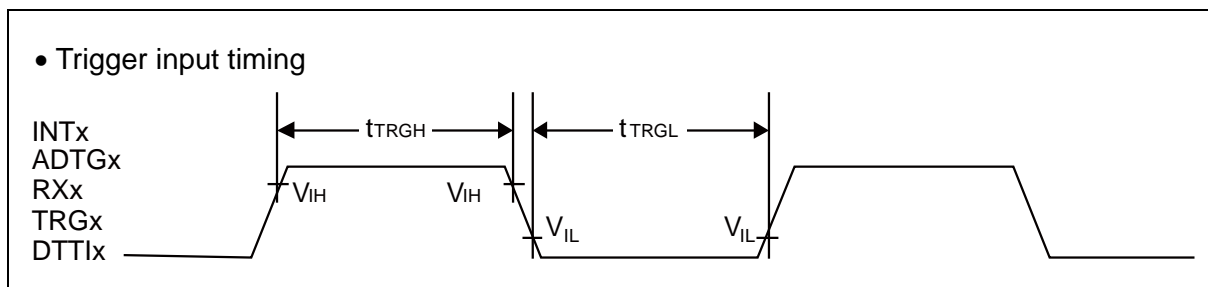

## (7) NMI input timing

(T<sub>A</sub>: Recommended operating conditions, V<sub>CC</sub> = 5.0V ± 10%, V<sub>SS</sub> = AV<sub>SS</sub> = 0.0V)

Parameter	Symbol	Pin name	Conditions	Value		Unit	Remarks
				Min	Max		
Input pulse width	t <sub>NMIL</sub>	NMIX	-	4t <sub>CPP</sub>	-	ns	

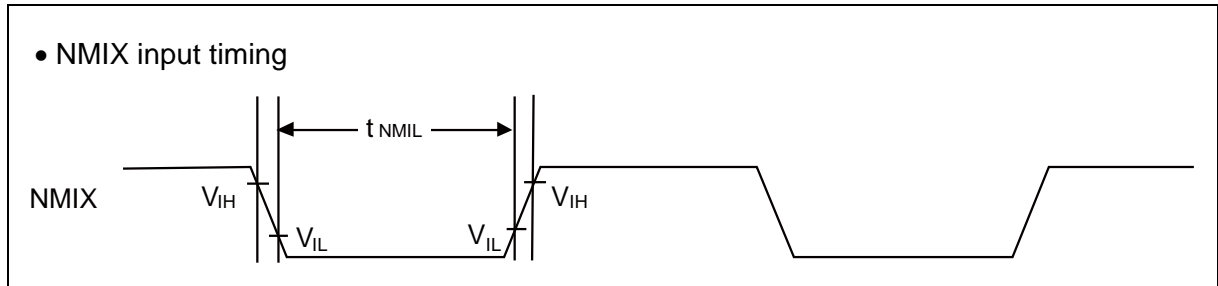

# MB91580L Series

## (8) Low-voltage detection (External low-voltage detection)

(T<sub>A</sub>: Recommended operating conditions, V<sub>SS</sub>=AV<sub>SS</sub>=0.0V)

Parameter	Symbol	Pin name	Conditions	Value			Unit	Remarks
				Min	Typ	Max		
Power supply voltage range	V <sub>DP5</sub>	VCC5	-	-	-	5.5	V	
Detection voltage	V <sub>DL</sub>	VCC5	*1	3.7	3.9	4.1	V	When power supply voltage falls and detection level is set initially
Hysteresis width	V <sub>HYS</sub>	VCC5	-	-	-	125	mV	When power supply voltage rises
Low-voltage detection time	T <sub>d</sub>	-	-	-	-	30	μs	
Power supply voltage fluctuation rate	-	VCC5	-	-2	-	2	V/ms	*2

\*1: If the fluctuation of the power supply has exceeded the detection voltage range within the time less than the low-voltage detection time (T<sub>d</sub>), there is the possibility to generate or release after the power supply voltage has exceeded the detection voltage range.

\*2: In order to perform the low-voltage detection at the detection voltage (V<sub>DL</sub>), be sure to suppress fluctuation of the power supply within the limits of the power supply voltage fluctuation rate.

## (9) Low-voltage detection (Internal low-voltage detection)

(T<sub>A</sub>: Recommended operating conditions, V<sub>SS</sub>=AV<sub>SS</sub>=0.0V)

Parameter	Symbol	Pin name	Conditions	Value			Unit	Remarks
				Min	Typ	Max		
Power supply voltage range	V <sub>RDP5</sub>	-	-	-	-	1.3	V	
Detection voltage	V <sub>RDL</sub>	-	*	0.8	0.9	1.0	V	When power supply voltage falls
Hysteresis width	V <sub>RHYS</sub>	-	-	-	-	50	mV	When power supply voltage rises
Low-voltage detection time	-	-	-	-	-	30	μs	

\*: If the fluctuation of the power supply is faster than the low-voltage detection time (T<sub>d</sub>), there is a possibility to generate or release after the power supply voltage has exceeded the detection voltage range.

## (10) Clock output timing

(T<sub>A</sub>: Recommended operating conditions, V<sub>CC</sub>=AV<sub>CC</sub>=5.0V±10%, V<sub>SS</sub>=AV<sub>SS</sub>=0.0V)

Parameter	Symbol	Pin name	Conditions	Value		Unit	Remarks
				Min	Max		
Cycle time	t <sub>CYC</sub>	SYCLK	-	t <sub>CP1</sub>	-	ns	
SYCLK ↑ → SYCLK ↓	t <sub>CHCL</sub>	SYCLK		(1/2 t <sub>CYC</sub> )- 7	(1/2 t <sub>CYC</sub> )+ 7	ns	
SYCLK ↓ → SYCLK ↑	t <sub>CLCH</sub>	SYCLK		(1/2 t <sub>CYC</sub> )- 7	(1/2 t <sub>CYC</sub> )+ 7	ns	

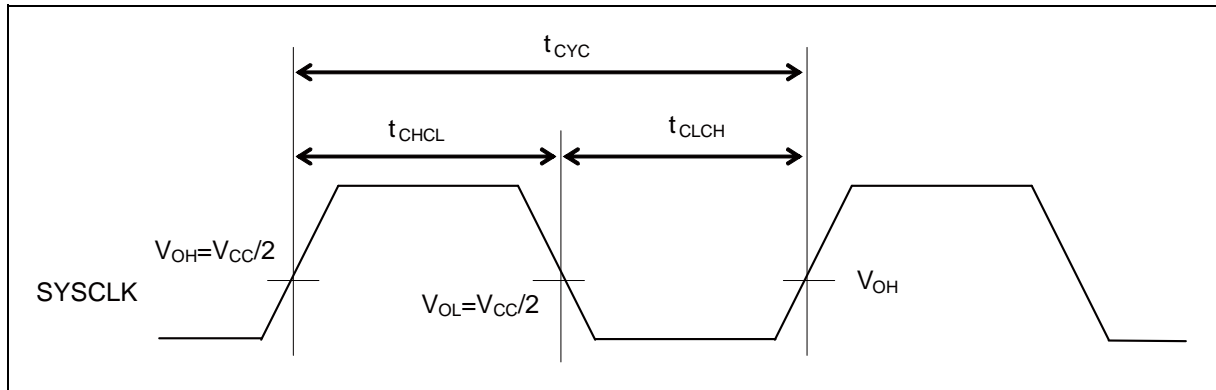

# MB91580L Series

## (11) External bus I/F (synchronous mode) timing

(T<sub>A</sub>: Recommended operating conditions, V<sub>CC</sub> = AV<sub>CC</sub> = 5.0V ± 10%, V<sub>SS</sub> = AV<sub>SS</sub> = 0.0V)  
(External load capacitance 50pF)

Parameter	Symbol	Pin name	Value		Unit	Remarks
			Min	Max		
Cycle time	t <sub>CYC</sub>	SYSCLK	25	-	ns	
ASX delay time	t <sub>CHASL</sub> , t <sub>CHASH</sub>	SYSCLK, ASX	0.5	18.0	ns	
CS0X to CS3X delay time	t <sub>CHCSL</sub> , t <sub>CHCSH</sub>	SYSCLK, CS0X to CS3X	0.5	18.0	ns	
A00 to A21 delay time	t <sub>CHAV</sub> , t <sub>CHAX</sub>	SYSCLK, A00 to A21	0.5	18.0	ns	
RDX delay time	t <sub>CHRL</sub> , t <sub>CHRH</sub>	SYSCLK, RDX	0.5	18.0	ns	
RDX minimum pulse	t <sub>RLRH</sub>	RDX	t <sub>CYC</sub> × 2 - 20	-	ns	RWT=1, set RWT to 1 or more.*
Data setup → RDX ↑ time	t <sub>DSRH</sub>	RDX, D16 to D31	18 + t <sub>CYC</sub>	-	ns	RWT=1, set RWT to 1 or more.*
RDX ↑ → data hold	t <sub>RHDH</sub>		0	-	ns	
WRnX delay time	t <sub>CHWL</sub> , t <sub>CHWH</sub>	SYSCLK, WROX, WR1X	0.5	18.0	ns	
WRnX minimum pulse width	t <sub>WLWH</sub>	WROX, WR1X	t <sub>CYC</sub> - 10	-	ns	WWT=0*
SYSCLK ↑ → data output time	t <sub>CHDV</sub>	SYSCLK, D16 to D31	0.5	18.0	ns	
SYSCLK ↑ → data hold time	t <sub>CHDX</sub>		-	18	ns	Set WRCS to 1 or more.
SYSCLK ↑ → address output time	t <sub>CHMAV</sub>	SYSCLK, D16 to D31	0.5	18.0	ns	
SYSCLK ↑ → address hold time	t <sub>CHMAX</sub>		-	18	ns	In multiplex mode, set as follows: • Set CSWR and CSRD to 2 or more. • Set to ADCY > ASCY. To prevent protocol violation, satisfy the following conditions: ADCY + 1 ≤ ACS + CSRD ADCY + 1 ≤ ACS + CSWR ASCY + 1 ≤ ACS + CSRD ASCY + 1 ≤ ACS + CSWR For details, see Hardware Manual.

\*: If the bus is expanded by automatic wait insertion or RDY input, add time (t<sub>CYC</sub> × the number of expanded cycles) to the rated value.



External bus I/F (synchronous mode, read operation, and multiplex mode) timing

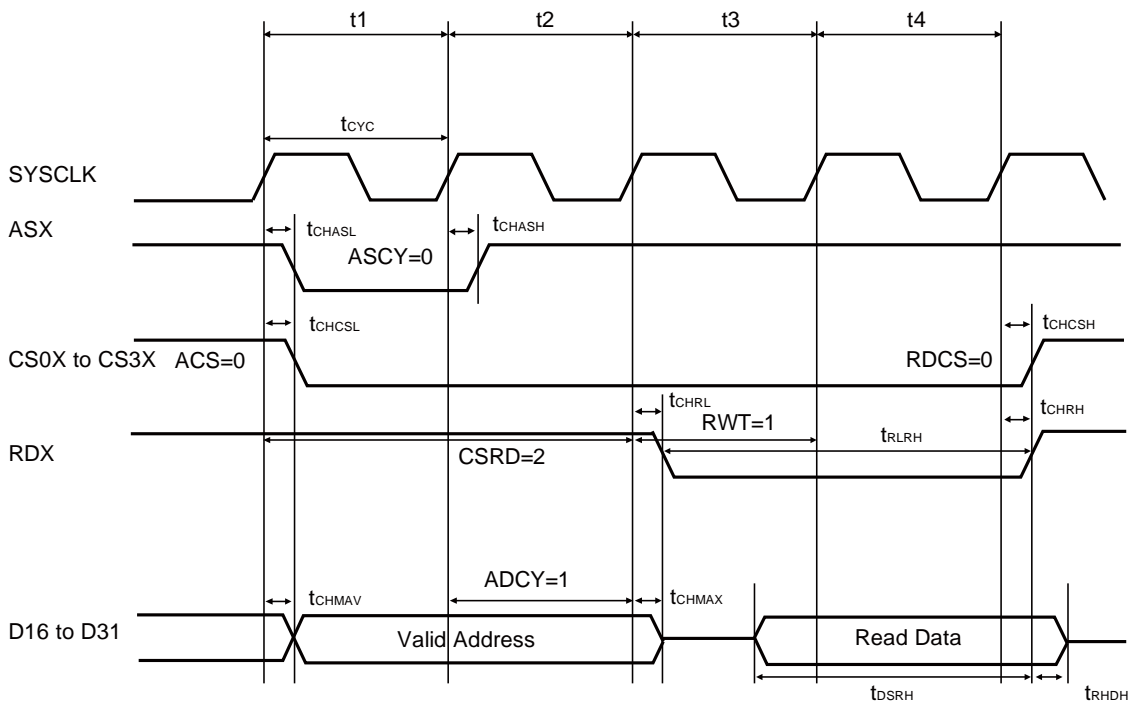

External bus I/F (synchronous mode, read operation, and split mode) timing

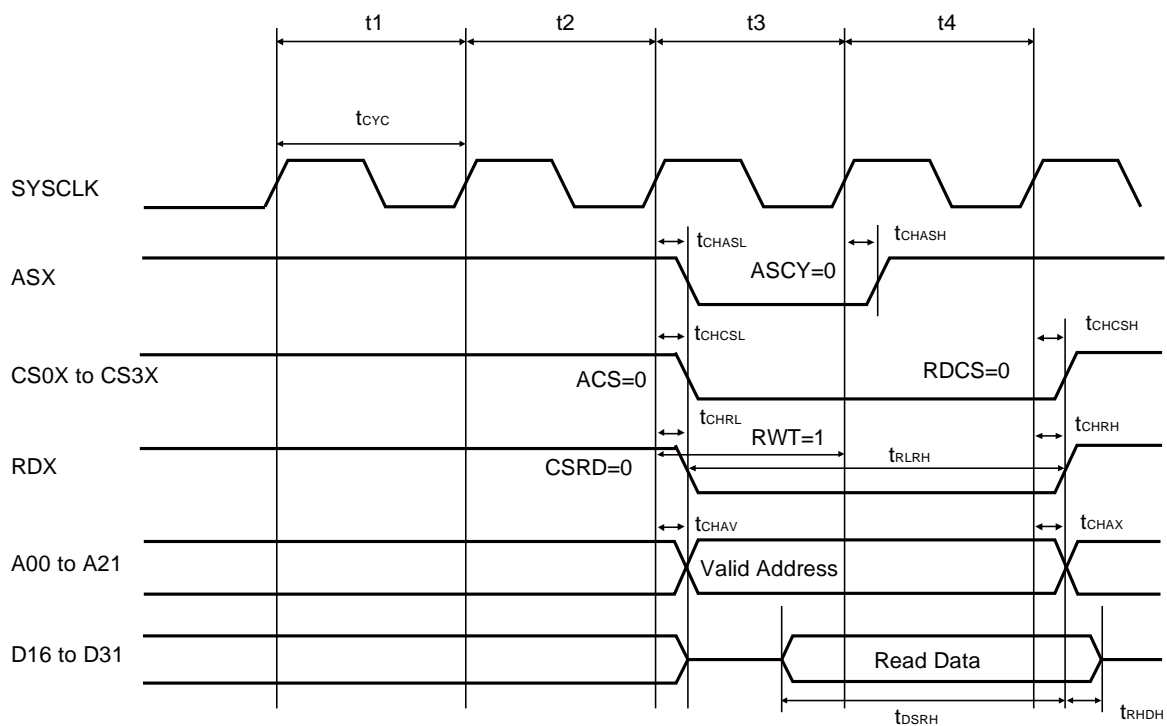

External bus I/F (synchronous mode, write operation, and multiplex mode) timing

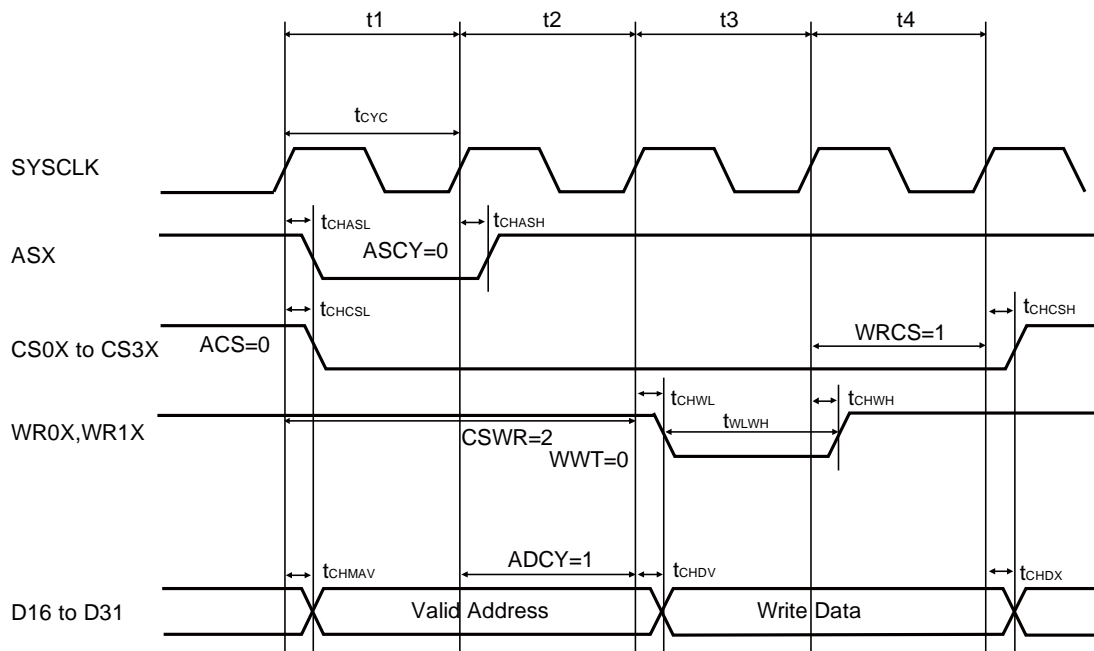

External bus I/F (synchronous mode, write operation, and split mode) timing

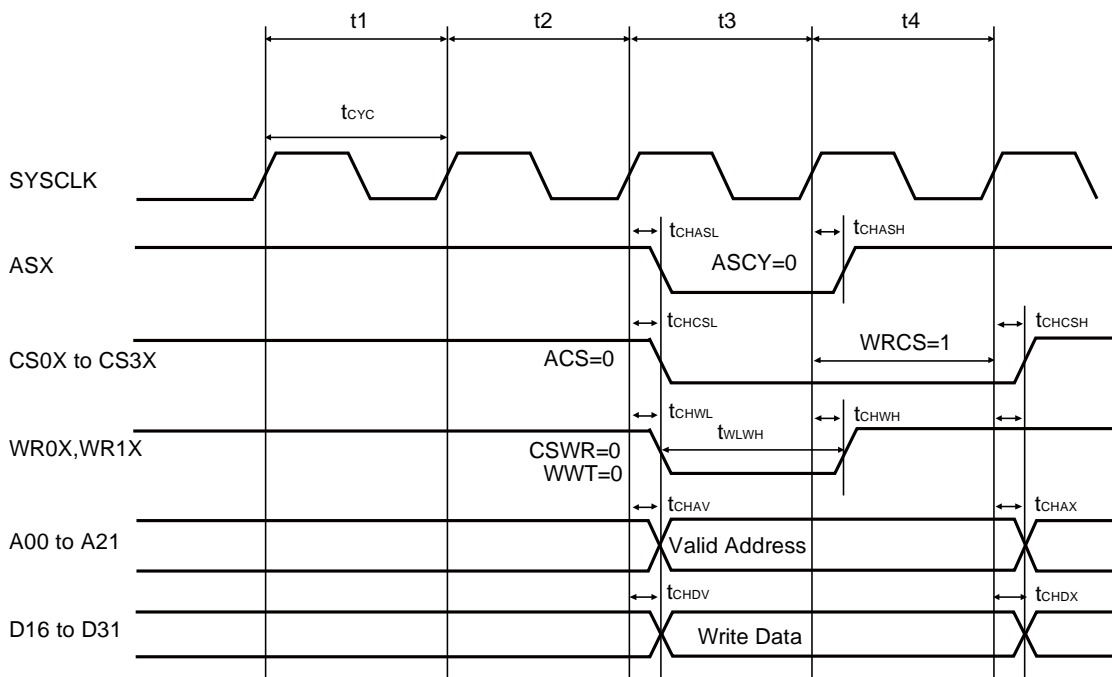

## (12) External bus I/F (Asynchronous mode) timing

(T<sub>A</sub>: Recommended operating conditions, V<sub>CC</sub> = AV<sub>CC</sub>=5.0V±10%, V<sub>SS</sub>=AV<sub>SS</sub>=0.0V)  
(External load capacitance 50pF)

Parameter	Symbol	Pin name	Value		Unit	Remarks
			Min	Max		
Cycle time	t <sub>CYC</sub>	SYCLK	25	-	ns	
Address setup → RDX ↑ time	t <sub>ASRH</sub>	RDX, A00 to A21	2 × t <sub>CYC</sub> - 12	2 × t <sub>CYC</sub> + 12	ns	RWT=1, set RWT to 1 or more.*
RDX ↑ → Address hold	t <sub>RHAH</sub>		t <sub>CYC</sub> - 12	t <sub>CYC</sub> + 12	ns	Set RDCS to 1 or more.
Data setup → RDX ↑ time	t <sub>DSRH</sub>	RDX, D16 to D31	18 + t <sub>CYC</sub>	-	ns	RWT=1, set RWT to 1 or more.
RDX ↑ → Data hold	t <sub>RHDH</sub>		0	-	ns	
Address setup → WRnX ↑ time	t <sub>ASWH</sub>	WR0X to WR1X, A00 to A21	t <sub>CYC</sub> - 12	t <sub>CYC</sub> + 12	ns	WWT=0.*
WRnX ↑ → Address hold	t <sub>WHAH</sub>		t <sub>CYC</sub> - 12	t <sub>CYC</sub> + 12	ns	Set WRCS to 1 or more.
Data setup → WRnX ↑ time	t <sub>DSWH</sub>	WR0X to WR1X, D16 to D31	t <sub>CYC</sub> - 16	t <sub>CYC</sub> + 16	ns	WWT=0.*
WRnX ↑ → Data hold	t <sub>WHDH</sub>		t <sub>CYC</sub> - 16	t <sub>CYC</sub> + 16	ns	Set WRCS to 1 or more.
Address setup → ASX ↑ time	t <sub>MASASH</sub>	ASX, D16 to D31	t <sub>CYC</sub> - 16	t <sub>CYC</sub> + 16	ns	ASCY=0.
ASX ↑ → Address hold	t <sub>MASHAH</sub>		t <sub>CYC</sub> - 16	t <sub>CYC</sub> + 16	ns	In multiplex mode, set as follows: <ul style="list-style-type: none"> <li>• Set CSWR and CSRD to 2 or more.</li> <li>• Set to ADCY &gt; ASCY.</li> </ul> To prevent protocol violation, satisfy the following conditions: ADCY + 1 ≤ ACS + CSRD ADCY + 1 ≤ ACS + CSWR ASCY + 1 ≤ ACS + CSRD ASCY + 1 ≤ ACS + CSWR For details, see Hardware Manual.

\*: If the bus is expanded by automatic wait insertion or RDY input, add time (t<sub>CYC</sub> × the number of expanded cycles) to the rated value.

# MB91580L Series

External bus I/F (asynchronous mode, read operation, and multiplex mode) timing

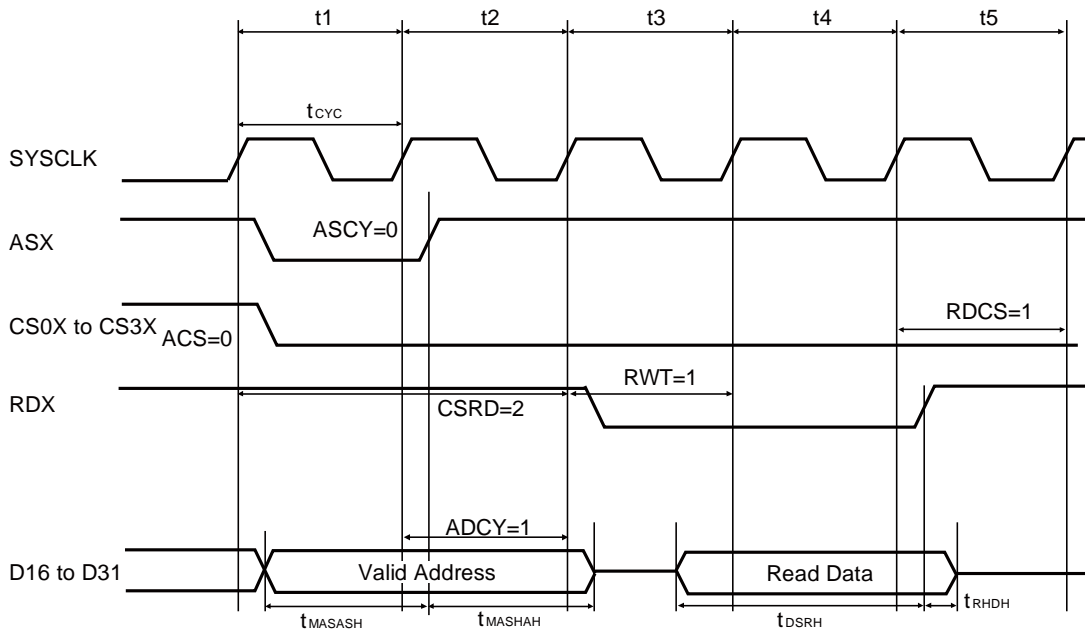

External bus I/F (asynchronous mode, read operation, and split mode) timing

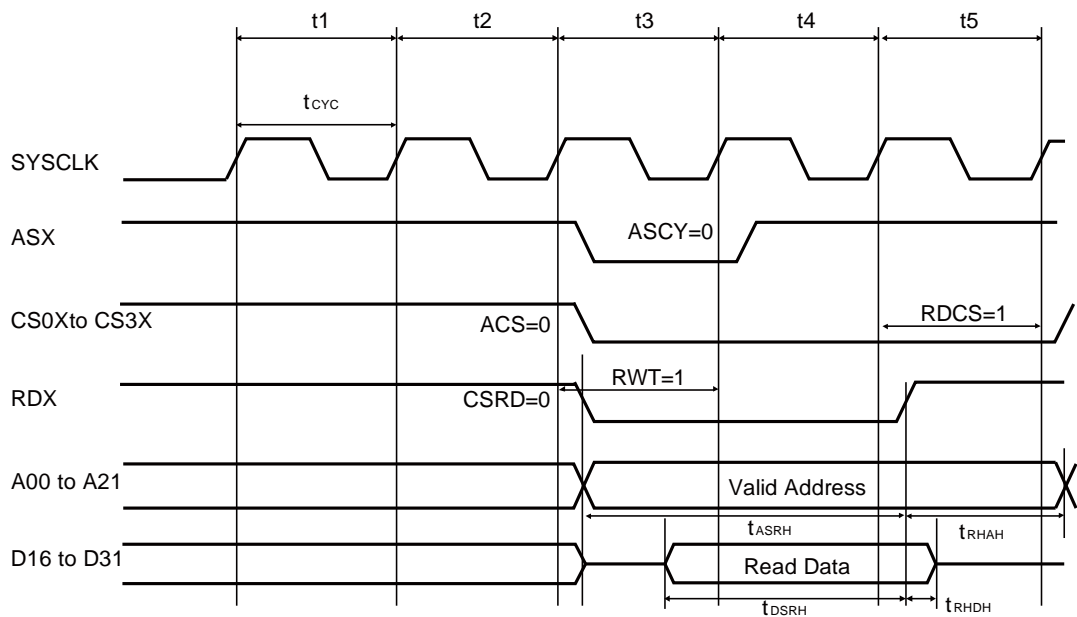

External bus I/F (asynchronous mode, write operation, and multiplex mode) timing

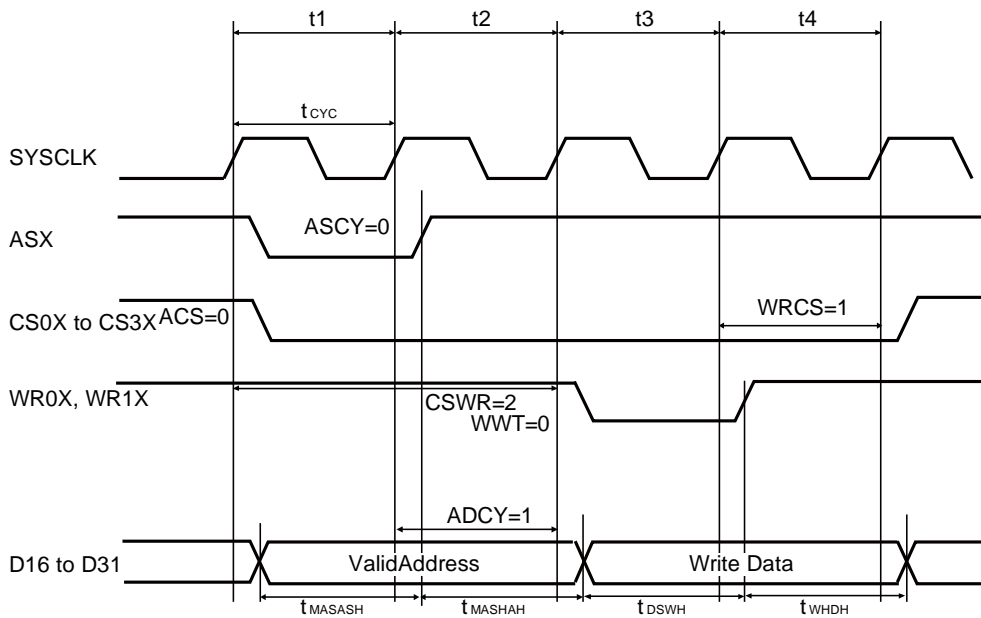

External bus I/F (asynchronous mode, write operation, and split mode) timing

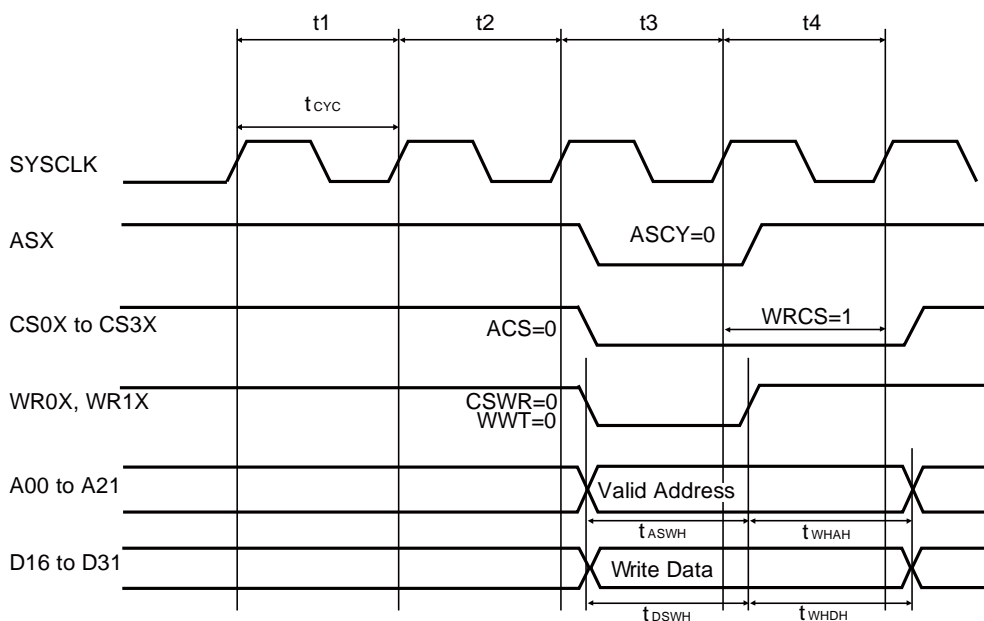

# MB91580L Series

## (13) External bus I/F (ready) timing

(T<sub>A</sub>: Recommended operating conditions, V<sub>CC</sub>=AV<sub>CC</sub>=5.0V±10%, V<sub>SS</sub>=AV<sub>SS</sub>=0.0V)  
 (External load capacitance 50pF)

Parameter	Symbol	Pin name	Value		Unit	Remarks
			Min	Max		
Cycle time	t <sub>CYC</sub>	SYSCLK	50	-	ns	If using RDY, set SYSCLK to 20 MHz or less.
RDY setup time → SYSCLK ↑	t <sub>RDYS</sub>	SYSCLK, RDY	28	-	ns	
SYSCLK ↑ → RDY hold time	t <sub>RDYH</sub>	SYSCLK, RDY	0	-	ns	

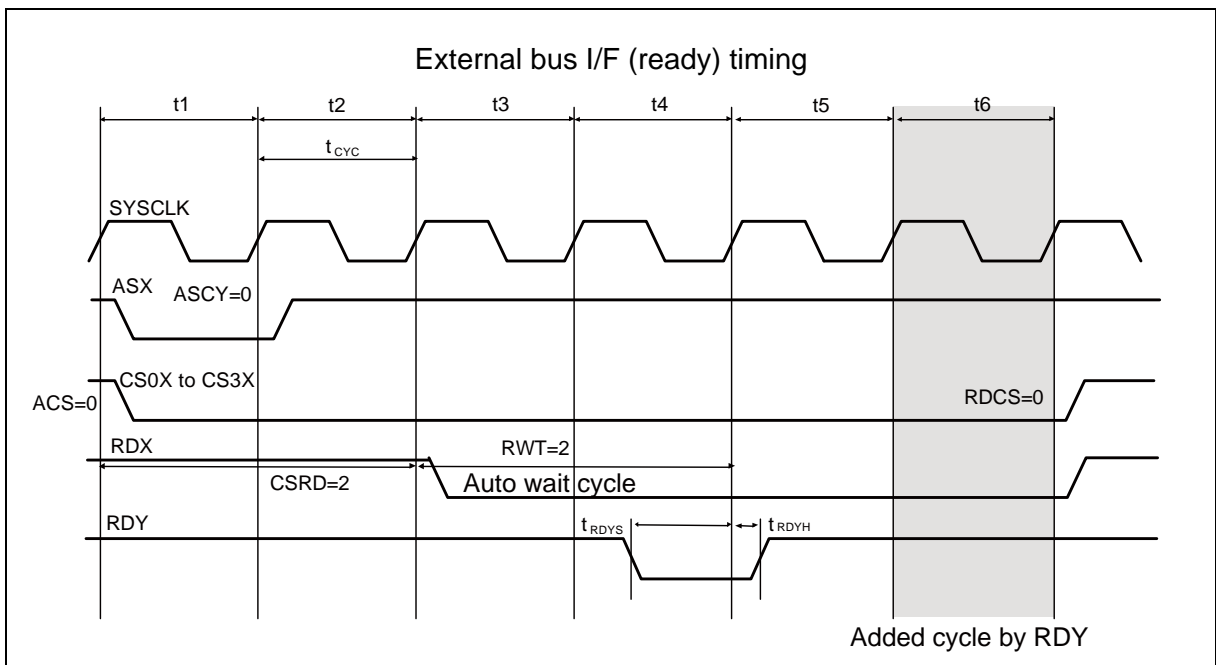

## 5. A/D Converter

### (1) Electrical Characteristics

(T<sub>A</sub>: Recommended operating conditions, V<sub>CC</sub>=5.0V±10%, AV<sub>CC</sub>=5.0V±10%, V<sub>SS</sub>=AV<sub>SS</sub>=0.0V)

Parameter	Symbol	Pin name	Value			Unit	Remarks
			Min	Typ	Max		
Resolution	-	-	-	-	12	bit	
Non linearity error	-	-	-4.0	-	+4.0	LSB	
Differential linearity error	-	-	-1.9	-	+1.9	LSB	
Zero transition voltage	V <sub>OT</sub>	AN0 to AN23	AVRL+0.5LSB-20	-	AVRL+0.5LSB+20	mV	1LSB=(VFST-VOT)/4094
Full-scale transition voltage	V <sub>FST</sub>	AN0 to AN23	AVRH-1.5LSB-20	-	AVRH-1.5LSB+20	mV	
Sampling time	t <sub>SMP</sub>	-	0.3	-	12	μs	*1
Compare time	t <sub>CMP</sub>	-	0.7	-	28	μs	*1
A/D conversion time	t <sub>CNV</sub>	-	1.0	-	40	μs	*1
Analog port input current	I <sub>AIN</sub>	AN0 to AN23	-1.0	-	1.0	μA	V <sub>AVSS</sub> ≤ V <sub>AIN</sub> ≤ V <sub>AVCC</sub>
Analog input voltage	V <sub>AIN</sub>	AN0 to AN23	AV <sub>SS</sub>	-	AVRH	V	
Reference voltage	AVRH	AVRH1, AVRH2, AVRH3	4.5	-	5.5	V	Avcc ≥ AVRH
	AVRL	AVRL1, AVRL2, AVRL3	-	0.0	-	V	
Power supply current	I <sub>A</sub>	AVCC3	-	1.5	2.1	mA	3 units operating
	I <sub>AH</sub>		-	-	25	μA	3 units operating *2
	I <sub>R</sub>	AVRH1, AVRH2, AVRH3	-	3	6	mA	3 units operating
	I <sub>RH</sub>		-	-	4.8	μA	3 units operating *2
Variation between channels	-	AN0 to AN23	-	-	4	LSB	

\*1: Time for each channel.

\*2: The power supply current (V<sub>CC</sub>=AV<sub>CC</sub>=5.0V) is specified if the A/D converter is not operating and CPU is stopped.

# MB91580L Series

## (2) Definition of Terms

- Resolution: Analog variation that is recognized by an A/D converter.
- Linearity error : Deviation of the actual conversion characteristics from a straight line that connects the zero transition point ("0000 0000 0000" ←→ "0000 0000 0001") to the full-scale transition point ("1111 1111 1110" ←→ "1111 1111 1111").
- Differential linearity error: Deviation of the input voltage from the ideal value that is required to change the output code by 1LSB.

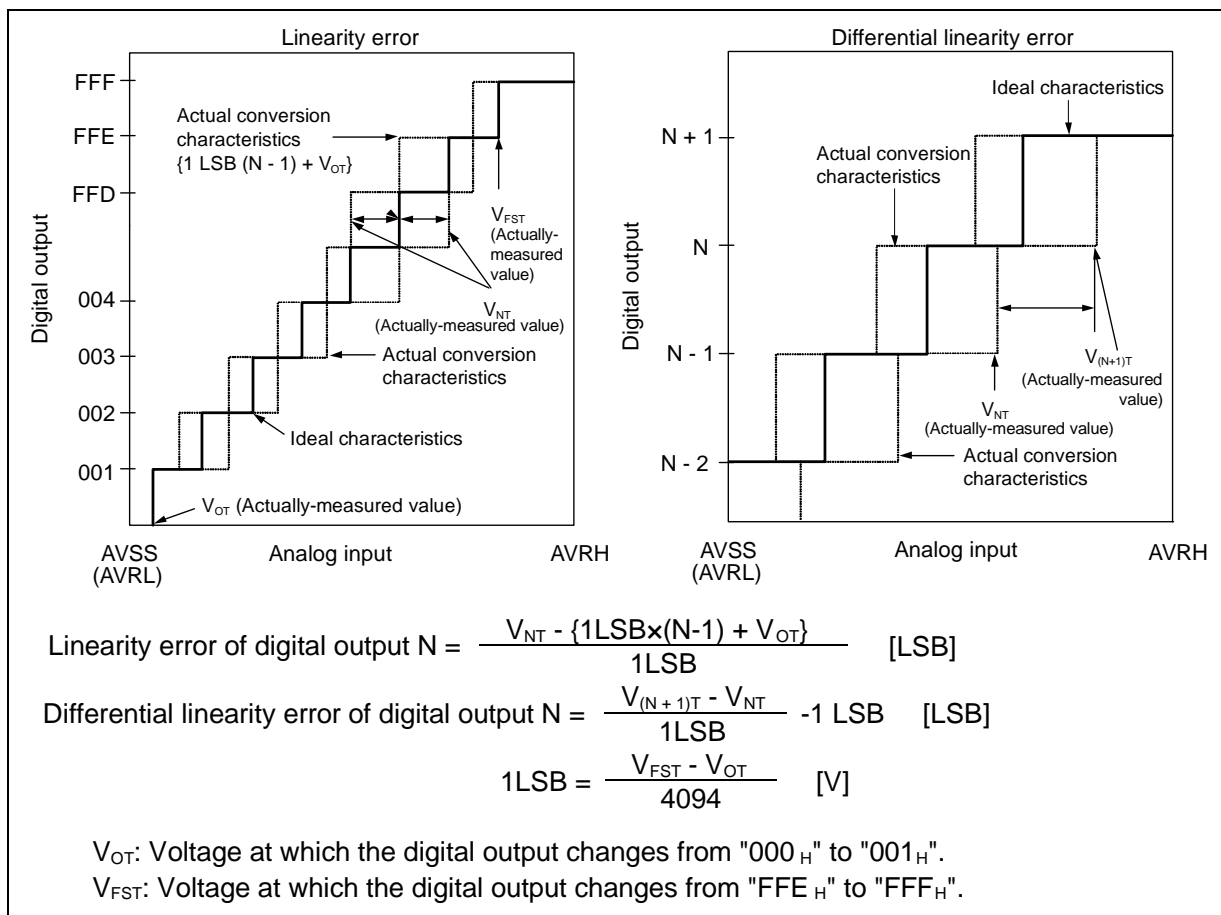

## (3) Notes on Using A/D Converter

<About the output impedance of the analog input of external circuit>

When the external impedance is too high, the sampling time for analog voltages may not be sufficient.

In this case, it is recommended to connect the capacitor (approx. 0.1 μF) to the analog input pin.

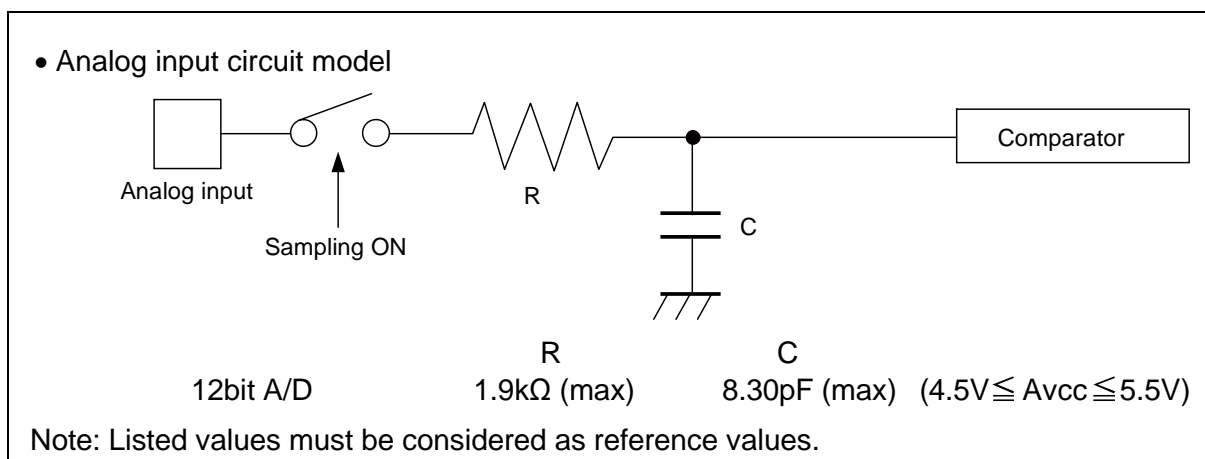



## 6. D/A Converter

(T<sub>A</sub>: Recommended operating conditions, V<sub>CC</sub>=AV<sub>CC</sub>=5.0V±10%, V<sub>SS</sub>=AV<sub>SS</sub>=0.0V)

Parameter	Symbol	Pin name	Value			Unit	Remarks
			Min	Typ	Max		
Resolution	-	-	-	-	10	bit	
Differential linearity error	-	-	-4.0	-	+4.0	LSB	When the analog output voltage is 0.5V to 4.5V

# MB91580L Series

## 7. Flash memory

### (1) Main flash

Parameter	Value			Unit	Remarks
	Min	Typ	Max		
Sector erase time	-	200	800	ms	8 Kbyte sector <sup>*1</sup> excluding internal preprogramming time
	-	300	1100	ms	8 Kbyte sector <sup>*1</sup> including internal preprogramming time
	-	400	2000	ms	64 Kbyte sector <sup>*1</sup> excluding internal preprogramming time
	-	700	3700	ms	64 Kbyte sector <sup>*1</sup> including internal preprogramming time
8-bit writing time	-	9	288	μs	Excluding overhead time at system level <sup>*1</sup>
16-bit writing time	-	12	384	μs	Excluding overhead time at system level <sup>*1</sup>
ECC writing time	-	9	288	μs	Excluding overhead time at system level <sup>*1</sup>
Erase cycle <sup>*2</sup> / Data retention time	1,000 cycles/20 years, 10,000 cycles/10 years, 100,000 cycles/5 years	-	-	-	Temperature at writing/erasing T <sub>j</sub> < +105°C Average temperature T <sub>A</sub> = +85°C <sup>*3</sup>

\*1: The guaranteed value for erase up to 100,000 cycles

\*2: Number of erase cycles for each sector

\*3: This value comes from the technology qualification (using Arrhenius equation to translate high temperature measurements into normalized value at + 85°C).

## (2) Notes

While the Flash memory is written or erased, shutdown of the external power supply ( $V_{CC}$ ) is prohibited. In the application system where  $V_{CC}$  might disappear while writing, be sure to turn the power off by using an external low-voltage detector.

To put it concretely, after the external power supply voltage falls below the detection voltage ( $V_{DL}^*$ ), hold  $V_{CC}$  at 2.7V or more within the duration calculated by the following expression:

$$T_d^*[\mu s] + (\text{period of PCLK} [\mu s] \times 257) + 50[\mu s]$$

\*: See "4. AC characteristics (8) Low-voltage detection (External low-voltage detection)."

# MB91580L Series

## 8. R/D Converter

(T<sub>A</sub>: Recommended operating conditions, V<sub>CC</sub> = AV<sub>CC</sub> = 5.0V ± 5%, V<sub>SS</sub> = AV<sub>SS</sub> = 0.0V)

Parameter		Value			Unit	Remarks
		Min	Typ	Max		
Excitation signal output	Output voltage (amplitude)	0.4V <sub>CC</sub> -1%	0.4V <sub>CC</sub>	0.4V <sub>CC</sub> +1%	V	
	Output voltage (displacement)	-0.4V <sub>CC</sub> +(V <sub>CC</sub> /2)	-	0.4V <sub>CC</sub> +(V <sub>CC</sub> /2)	V	
	Output current	-	-	1	mA	
	Frequency	-	10 or 20	-	kHz	Setting with the register
Resolver response signal*1	Amplitude	AREF2-2.0	-	AREF2+2.0	V	
	Maximum input frequency	-	-	24	kHz	
Excitation input signal*2	Amplitude	0	-	AV <sub>CC0</sub>	V	
	Phase difference from resolver detection signal	-45	-	45	°	
Angle output	Angle accuracy (conversion accuracy)	-4	-	4	LSB	Variation when pausing: ±1LSB
	Resolution	-	12	-	bit	
	Output delay	1.1	-	2.1	μs	
Angular velocity output	Maximum angular velocity	-	-	4000	rps	When bandwidth 1.8kHz mode
		-	-	3000	rps	When bandwidth 600kHz mode
	Resolution	-	0.261	-	rps/LSB	
Reference output voltage	AREF2 output voltage	AV <sub>CC0</sub> /2-3%	-	AV <sub>CC0</sub> /2+3%	V	
Operating characteristics	Tracking loop characteristics (0dB cross frequency)	-	-	1.2	kHz	When bandwidth 1.8kHz mode*3
		-	-	400	Hz	When bandwidth 600Hz mode*3
	Tracking loop characteristics (-3dB cross frequency)	-	-	1.8	kHz	When bandwidth 1.8kHz mode*3
		-	-	600	Hz	When bandwidth 600Hz mode*3
	Maximum tracking rate	-	-	4000	rps	When bandwidth 1.8kHz mode
		-	-	3000	rps	When bandwidth 600Hz mode
	Settling time (179° step).	-	-	4	ms	When bandwidth 1.8kHz mode
		-	-	12	ms	When bandwidth 600Hz mode
	Maximum angular velocity	-	-	1,000,000	rad/s2	When bandwidth 1.8kHz mode
		-	-	150,000	rad/s2	When bandwidth 600Hz mode

\*1: Corresponding pin: COS\_PLUS, COS\_MINUS, SIN\_PLUS, SIN\_MINUS

\*2: Corresponding pin: MAG\_PLUS, MAG\_MINUS

\*3: When signal amplitude is nominal

# MB91580L Series

## ■ ORDERING INFORMATION

Part number	Package*
MB91F585LAPMC-GTE1 MB91F586LAPMC-GTE1 MB91F587LAPMC-GTE1	144-pin plastic LQFP (FPT-144P-M08)
MB91F585LBPMC-GTE1 MB91F586LBPMC-GTE1 MB91F587LBPMC-GTE1	144-pin plastic LQFP (FPT-144P-M08)
MB91F585LCPMC-GTE1 MB91F586LCPMC-GTE1 MB91F587LCPMC-GTE1	144-pin plastic LQFP (FPT-144P-M08)
MB91F585LDPMC-GTE1 MB91F586LDPMC-GTE1 MB91F587LDPMC-GTE1	144-pin plastic LQFP (FPT-144P-M08)

\*: For details of the package, see "■ PACKAGE DIMENSIONS".

# MB91580L Series

## ■ PACKAGE DIMENSIONS

<p>144-pin plastic LQFP</p> <p>(FPT-144P-M08)</p>	Lead pitch	0.50 mm
	Package width × package length	20.0 × 20.0 mm
	Lead shape	Gullwing
	Sealing method	Plastic mold
	Mounting height	1.70 mm MAX
	Weight	1.20 g
	Code (Reference)	P-LFQFP144-20×20-0.50

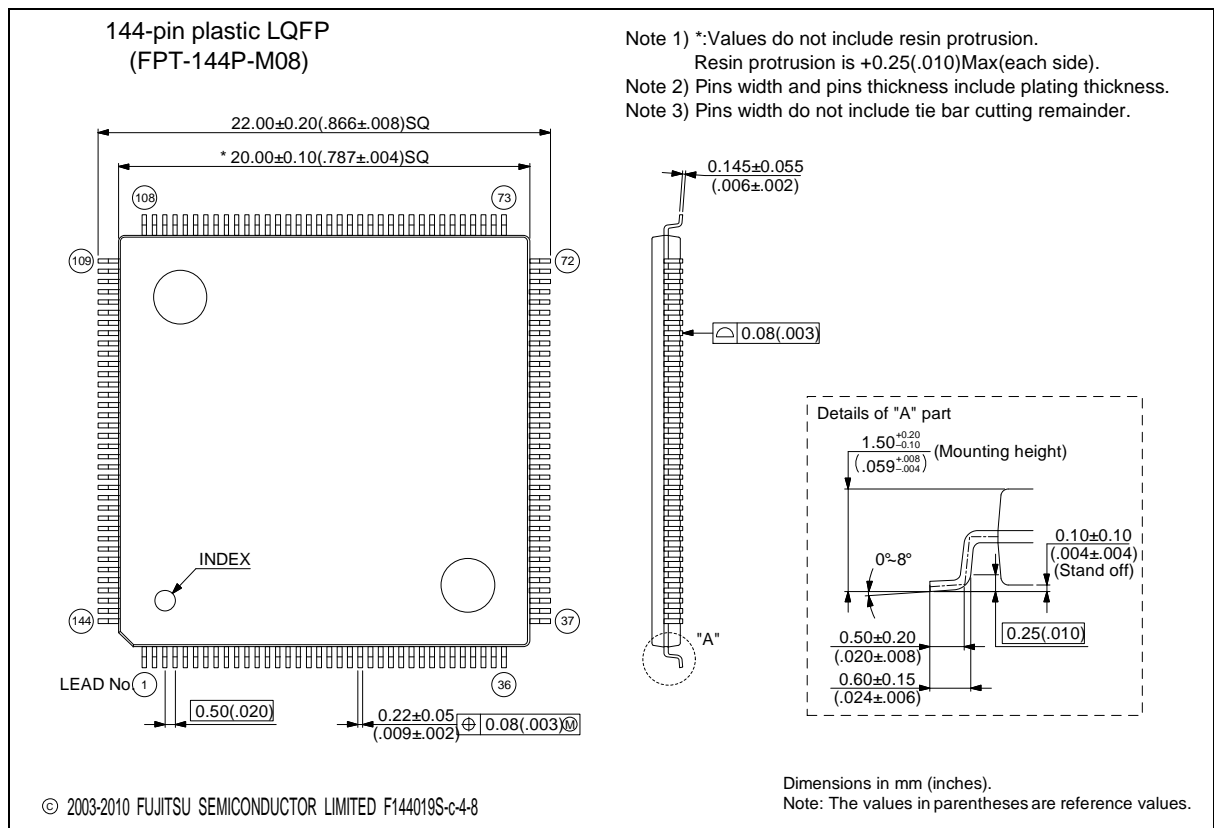

Please check the latest package dimension at the following URL.  
<http://edevic.fujitsu.com/package/en-search/>

**MEMO**

# MB91580L Series

## FUJITSU SEMICONDUCTOR LIMITED

Nomura Fudosan Shin-yokohama Bldg. 10-23, Shin-yokohama 2-Chome,  
Kohoku-ku Yokohama Kanagawa 222-0033, Japan

Tel: +81-45-415-5858

<http://jp.fujitsu.com/fsl/en/>

*For further information please contact:*

### North and South America

FUJITSU SEMICONDUCTOR AMERICA, INC.

1250 E. Arques Avenue, M/S 333

Sunnyvale, CA 94085-5401, U.S.A.

Tel: +1-408-737-5600 Fax: +1-408-737-5999

<http://us.fujitsu.com/micro/>

### Asia Pacific

FUJITSU SEMICONDUCTOR ASIA PTE. LTD.

151 Lorong Chuan,

#05-08 New Tech Park 556741 Singapore

Tel : +65-6281-0770 Fax : +65-6281-0220

<http://sg.fujitsu.com/semiconductor/>

### Europe

FUJITSU SEMICONDUCTOR EUROPE GmbH

Pittlerstrasse 47, 63225 Langen, Germany

Tel: +49-6103-690-0 Fax: +49-6103-690-122

<http://emea.fujitsu.com/semiconductor/>

FUJITSU SEMICONDUCTOR SHANGHAI CO., LTD.

30F, Kerry Parkside, 1155 Fang Dian Road,

Pudong District, Shanghai 201204, China

Tel : +86-21-6146-3688 Fax : +86-21-6146-3660

<http://cn.fujitsu.com/fss/>

### Korea

FUJITSU SEMICONDUCTOR KOREA LTD.

902 Kosmo Tower Building, 1002 Daechi-Dong,

Gangnam-Gu, Seoul 135-280, Republic of Korea

Tel: +82-2-3484-7100 Fax: +82-2-3484-7111

<http://kr.fujitsu.com/fsk/>

FUJITSU SEMICONDUCTOR PACIFIC ASIA LTD.

2/F, Green 18 Building, Hong Kong Science Park,

Shatin, N.T., Hong Kong

Tel : +852-2736-3232 Fax : +852-2314-4207

<http://cn.fujitsu.com/fsp/>

Specifications are subject to change without notice. For further information please contact each office.

### All Rights Reserved.

The contents of this document are subject to change without notice.

Customers are advised to consult with sales representatives before ordering.

The information, such as descriptions of function and application circuit examples, in this document are presented solely for the purpose of reference to show examples of operations and uses of FUJITSU SEMICONDUCTOR device; FUJITSU SEMICONDUCTOR does not warrant proper operation of the device with respect to use based on such information. When you develop equipment incorporating the device based on such information, you must assume any responsibility arising out of such use of the information.

FUJITSU SEMICONDUCTOR assumes no liability for any damages whatsoever arising out of the use of the information.

Any information in this document, including descriptions of function and schematic diagrams, shall not be construed as license of the use or exercise of any intellectual property right, such as patent right or copyright, or any other right of FUJITSU SEMICONDUCTOR or any third party or does FUJITSU SEMICONDUCTOR warrant non-infringement of any third-party's intellectual property right or other right by using such information. FUJITSU SEMICONDUCTOR assumes no liability for any infringement of the intellectual property rights or other rights of third parties which would result from the use of information contained herein.

The products described in this document are designed, developed and manufactured as contemplated for general use, including without limitation, ordinary industrial use, general office use, personal use, and household use, but are not designed, developed and manufactured as contemplated (1) for use accompanying fatal risks or dangers that, unless extremely high safety is secured, could have a serious effect to the public, and could lead directly to death, personal injury, severe physical damage or other loss (i.e., nuclear reaction control in nuclear facility, aircraft flight control, air traffic control, mass transport control, medical life support system, missile launch control in weapon system), or (2) for use requiring extremely high reliability (i.e., submersible repeater and artificial satellite).

Please note that FUJITSU SEMICONDUCTOR will not be liable against you and/or any third party for any claims or damages arising in connection with above-mentioned uses of the products.

Any semiconductor devices have an inherent chance of failure. You must protect against injury, damage or loss from such failures by incorporating safety design measures into your facility and equipment such as redundancy, fire protection, and prevention of over-current levels and other abnormal operating conditions.

Exportation/release of any products described in this document may require necessary procedures in accordance with the regulations of the Foreign Exchange and Foreign Trade Control Law of Japan and/or US export control laws.

The company names and brand names herein are the trademarks or registered trademarks of their respective owners.