

1 FEATURES

- Low external component count
- Constant ON cycle time, with proportional OFF time
- All ON cycles consist of an integral number of mains cycles
- No DC component in the mains supply
- On chip circuit protection against triac gate spikes
- Low supply current requirement
- Sensor AC powered, thus minimising DC supply and filtering needs
- OM1654A has separate power supply input, allowing easy gate pulse width adjustment

2 GENERAL DESCRIPTION

The OM1654A is a monolithic bipolar control circuit for zero-crossing triggering of a triac in applications where it is controlled by a resistive sensor such as an NTC (negative temperature coefficient) thermistor. In a typical application it can be used for the temperature control of a heating element in a cooker or another home heating or personal care appliance.

Separate power supply (PWR) and mains zero-crossing sensing (AC) inputs allow for optimal setting of gate pulse width.

Using a single resistor supply connected to AC, the OM1654A is designed to control a suitable triac over an ambient of 0 to 100 degrees Celsius with a resistive load ranging from 400 watts on a nominal 220/250 volt mains supply.

When using a separate supply resistor connector to the power supply pin (PWR), very small loads down to around 30W can be controlled.

The OM1654A can also be easily applied to 120Vac or other mains voltage applications.

3 BLOCK DIAGRAM

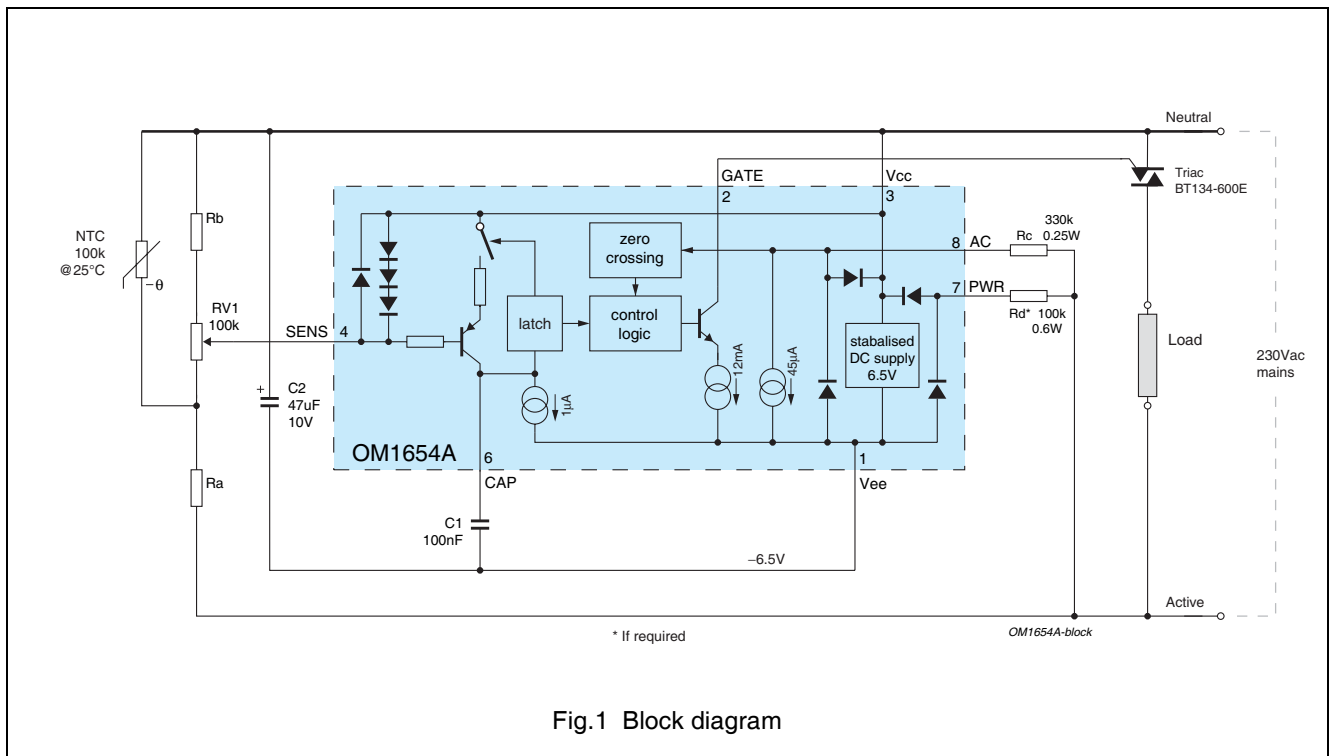

Fig.1 Block diagram

4 PINNING INFORMATION

4.1 Pinning layout (8 pin)

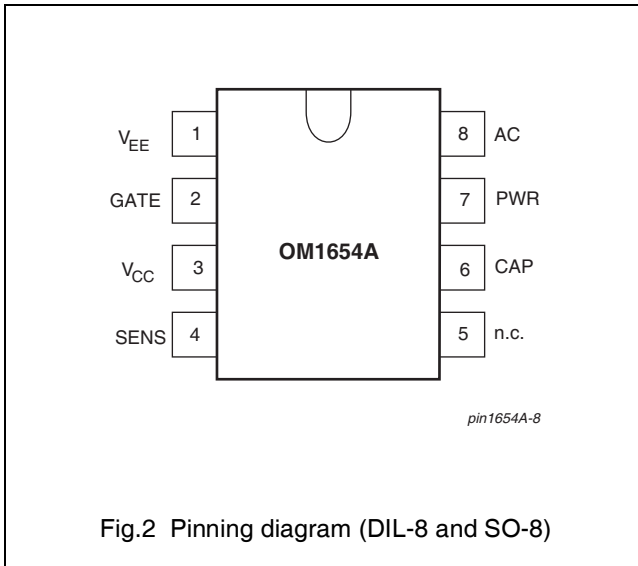

Fig.2 Pinning diagram (DIL-8 and SO-8)

4.2 Pin description (8 pin)

SYMBOL	PIN	DESCRIPTION
V_{EE}	1	Negative supply (SUBS)
GATE	2	Triac gate drive
V_{CC}	3	Positive supply (common, COM)
SENS	4	Temperature sense
n.c.	5	not connected
CAP	6	Timing capacitor
PWR	7	Power supply input
AC	8	Mains supply synchronisation

5 FUNCTIONAL DESCRIPTION

5.1 V_{CC} – Positive DC supply (Common)

The positive DC supply rail for the control IC OM1654A is used as the Common reference. This is connected to the T1 terminal of the triac, and being the positive supply rail enables negative gate drive to the triac in both positive and negative supply half cycles on T2. By driving the triac in this way the insensitive quadrant (negative T2 voltage, and positive gate triggering signal) is avoided.

5.2 V_{EE} – Negative DC supply

The V_{EE} connection is the negative DC power supply terminal of the OM1654A. This should be bypassed to V_{CC} by a filtering capacitor of 47 microfarads. The operating voltage is typically -6.5 volts. This capacitor

needs to be sufficiently large to maintain the operating voltage during the half cycle when it is not being charged, as well as to provide the energy to drive the triac gate during the gate pulse.

5.3 AC – AC signal, power supply and synchronisation

For the OM1654A the AC input is connected to the active mains supply rail via a resistor chosen to give the required gate pulse width, to ensure that during zero crossing of the mains cycle the gate signal is applied from before the load current falls below the triac holding current, until after the load current has increased to a value greater than the triac latching current. A resistor from PWR to V_{EE} may be required to ensure the gate drive pulse is still present when the negative mains voltage is insufficient

for the load current to have reached the negative latching current.

In the simplest application (optimised for a 400W load), the AC input is connected via a 220 k Ω resistor to the 220/250 volt AC mains supply line.

The AC input signal is rectified to provide some of the internal supply voltage, and also provides the synchronising information required by the OM1654A to generate the zero crossing signal.

5.4 PWR – Power supply

The pin (PWR) allows a lower value resistor to be used to provide an adequate DC power supply while also permitting easy adjustment of the gate pulse width with a high impedance network on the AC pin.

The PWR pin is driven by a resistor from the mains Active. This resistor is chosen to ensure that the DC power

supply is sufficient to provide the power supply necessary for the function of the OM1654A, and in addition to provide the energy needed for the gate drive. These calculations are described in the OM1654A application note AN002.

5.5 GATE – Triac gate drive

The triac gate drive output is designed to be connected directly to the gate. It has inbuilt protection to withstand transient signals which may be induced on the gate of the triac by mains transients during firing. The gate drive is designed for a triac with a gate sensitivity which requires less than 10 mA of triggering current, and a suitable latching current. One triac with suitable characteristics is the BTA208 series E when used with a load of more than 400 watts.

5.6 CAP – Timing capacitor

The timing capacitor is connected between this pin and V_{EE} (-ve). The discharge time of this capacitor sets

the triac ON time, and is proportional to the capacitance value (approximately 4 seconds per microfarad). The charging period, or OFF time, varies with the magnitude of the input signal from the sensor. The ON period is synchronised with the mains zero crossing signals so that an integral number of full cycles makes up the ON period, and no nett DC signal is generated in the supply line.

The initiation of an ON period is suppressed until the chip power supply reaches its regulated value.

After reaching a valid V_{EE} the chip will stay in operation even if the supply falls to about 4 volts. It won't start until the "zener" first conducts.

5.7 SENS – Sensor input

The sensor input is designed to accept an input which is an AC signal referenced to common; thereby avoiding problems associated with the power dissipation involved in

generating sufficient DC current to drive the sensor over its full operating resistance range. If a suitable resistive sensor is used with a parallel level setting potentiometer to apply a proportion of the AC sensor signal to the SENS input, a typical circuit will power this via a 220 kΩ resistor from the AC supply. The SENS input signal threshold is one V_{BE} below the V_{CC} rail. Signals with a magnitude greater than this V_{BE} charge the timing capacitor towards the V_{CC} rail until it reaches the threshold which initiates an ON cycle. Signals with a magnitude less than this do not charge the capacitor, and the triac drive remains OFF.

External circuits may be used to give greater temperature linearity and accuracy, and improved performance with variation in ambient temperature. The SENS input is only active on negative signals with respect to V_{CC} , and therefore either a full AC input may be used, or a signal that is only negatively going with respect to V_{CC} .

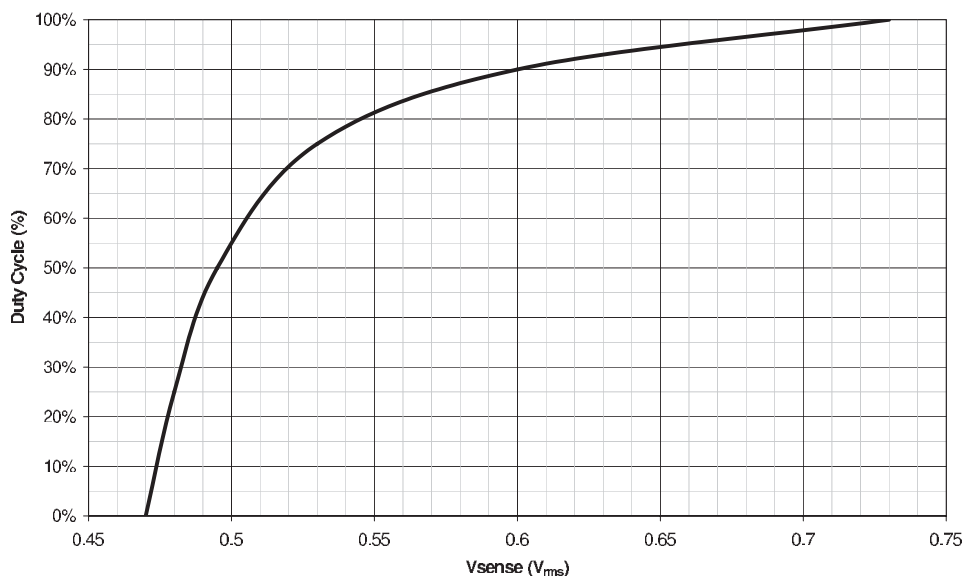

Fig.3 Control duty-cycle vs ac input voltage (V_{sense})

6 LIMITING VALUES

In accordance with the Absolute Maximum Rating System (IEC 134) Voltages with respect to V_{CC} pin 3.

SYMBOL	PARAMETER	CONDITIONS	MIN.	MAX.	UNIT
V_{supply}	Supply voltage range (V_{EE})	V_{1-3}	-7.6	+0.5	V
V_{AC}	Voltage range (AC)	V_{8-3}	-7.6	+0.5	V
V_{PWR}	Voltage range (AC)	V_{8-3}	-7.6	+0.5	V
V_{CAP}	Voltage range (CAP)	V_{6-3}	$V_{1-0.8}$	+0.8	V
V_{SENS}	Voltage range (SENS)	V_{4-3}	-1.6	+0.8	V
V_{GATE}	Voltage range (GATE)	V_{2-3}	V_{1-30}	+50	V
I	DC current (any pin)		-	20	mA
P_{tot}	total power dissipation		-	300	mW
T_{stg}	storage temperature		-40	+150	°C
T_{amb}	operating ambient temperature		0	+100	°C

7 CHARACTERISTICS

At $T_{amb} = 25^{\circ}\text{C}$; Voltages are specified with respect to V_{CC} , pin 3

SYMBOL	PARAMETER	CONDITIONS	MIN	TYP	MAX	UNIT
Power supply						
$-V_{EE}$	supply voltage (operating)		5.9	6.5	7.6	V
$-I_{EE}$	supply current (operating)	excluding gate drive	–	80	150	μA
Gate drive						
I_{GATE}	gate current (triac T1 to V_{CC})	$V_{GATE} = V_{CC}$	10	12.5	–	mA
Zero crossing detection						
I_{AC}	+ve threshold		–	45	–	μA
$-V_{AC}$	–ve threshold		–	6.4	–	V
Timing capacitor						
$-I_{CAP}$	discharge current		–	1	2.2	μA
$-V_{UT}$	upper threshold		–	1100	–	mV
$-V_{LT}$	lower threshold		–	$V_{EE}+1100$	–	mV
I_{CAP}	charge current	$I_{SENS} = -20 \mu\text{A}$	–	150	–	μA
Sense input						
$-V_{SENS}$	sense voltage	$I_{SENS} = -20 \mu\text{A}$	–	1000	–	mV
$-V_{SENS}$	sense voltage	duty cycle = 50%	–	575	–	mV
$-\Delta V_{SENS}/^{\circ}\text{C}$	temperature sensitivity		–	2.2	–	mV/ $^{\circ}\text{C}$
(see figure 3 for further information on control duty cycle vs input ac sense voltage)						
$V_{SENS(rms)}$	AC sense voltage	Duty cycle = 5%	–	0.47	–	$V_{(rms)}$
$V_{SENS(rms)}$	AC sense voltage	Duty cycle = 25%	–	0.48	–	$V_{(rms)}$
$V_{SENS(rms)}$	AC sense voltage	Duty cycle = 50%	–	0.50	–	$V_{(rms)}$
$V_{SENS(rms)}$	AC sense voltage	Duty cycle = 75%	–	0.53	–	$V_{(rms)}$
$V_{SENS(rms)}$	AC sense voltage	Duty cycle = 95%	–	0.65	–	$V_{(rms)}$
$V_{SENS(rms)}$	AC sense voltage	Duty cycle = 100%	–	0.73	–	$V_{(rms)}$

8 APPLICATION INFORMATION

8.1 Design considerations

Figure 4 shows a typical simple circuit for a load of greater than 400W. In this application the PWR pin is not used.

The power supply resistance of 220 k Ω for R3 sets the DC power supply current available for the

operation of the circuit. When it is required to fire the triac the gate pulse width must be sufficiently long to ensure that the triac load current is greater than the latching current when the gate pulse is removed. Hence the need to specify a minimum operating load for this circuit. At the same time most of the operating DC current derived through the resistor is used in

providing the gate signal, thereby putting a tight limit on the upper value of the width of the gate pulse. The width of the gate pulse is derived from the supply voltage and the instantaneous value of the current flowing through the power supply resistor.

In figure 5 an application circuit is shown for a 60W load, using the PWR pin as well as the AC input pin.

Using a BTA204W-600E triac for a 60W load on 220V means an 805Ω load. At 20mA latching current (positive), then the mains voltage for latching is 16V (with a margin use 20V) at a phase angle of 3.7 degrees. For 45μA in R3 when the mains voltage is 20V, then

$$R4 = 420k\Omega$$

The supply current at mains peak voltage in R3 is

$$(220 \times \sqrt{2}) / (420k) = 740\mu A$$

The negative latching current of the BTA204W is -15mA, giving a mains voltage at this time of -15V. Thus when the mains voltage is -15V, from the ratio of R3 and R5, the voltage on pin AC must be -6V. Therefore R5 = 270kΩ, and the firing angle 2.8 degrees.

The gate pulse width is 6.5 degrees, with a duty cycle of 3.6%. That is 722μA average for a peak (cold plus margin) gate current of -20mA.

Therefore the average current needed from the power supply is the average gate current, plus the maximum supply current, plus the average positive threshold current:

$$722 + 150 + \frac{45}{2} = 895\mu A$$

Of this $740/\pi = 235\mu A$ is supplied via R3, so R5 must supply a further 660 μA average through the PWR pin. Therefore R5 is 100 kΩ:

$$220 / (660 \times \pi) = 106k\Omega$$

A number of important characteristics of the triac are temperature sensitive. It is essential that the controlling integrated circuit exhibits comparable sensitivity to temperature change so that its characteristics vary in the same way as those of the triac, ensuring proper triggering over the full operating range.

NEGATIVE HALF CYCLE

A typical triac has a maximum latching current for the negative half cycle of 25 mA. If the gate pulse is terminated when the supply voltage falls below -6 volts, the minimum load can be calculated for which the holding current is reached before the supply voltage falls to this value. However, with the addition of resistors to V_{EE} and V_{CC} from the AC pin, other threshold voltages can be achieved, allowing other loads.

POSITIVE HALF CYCLE

A typical positive half cycle latching current is 35 mA. Considering chip resistor tolerances, and from the value of the mains power supply resistor of 220 kΩ in figure 4 the end of the gate pulse can be calculated using the threshold current of nominally 45 μA where the gate drive is turned off.

GATE CURRENT

In assuming a triac gate current of 10 mA minimum an on chip margin has to be allowed for component tolerances, and a suitable variation with ambient temperature. Also it needs to be realised that most of the supply current is used in providing the gate current.

Thus in characterising the OM1654 the design has taken into account the availability of suitably sensitive triacs, and used this to employ design figures enabling operation in specific applications with minimum external component count, and yet ensuring reliable triggering and proper operation over normal operating temperature and supply voltage conditions.

TEMPERATURE SENSING

The application circuit in figure 4 is the simplest configuration in which a

negative temperature coefficient (NTC) thermistor or another resistive sensing element can be used. Note that at the low temperature end of the potentiometer travel no sensing signal is available at all. However simple resistor networks are usually needed to linearise the response of the setting resistor against control temperature, and can easily be designed to allow for maximum and minimum operating points. Alternatively these might be set mechanically by stops inherent in the mechanical construction of the product using the OM1654A.

Some applications require more accurate control over a limited temperature range. Use of an input bridge circuit with gain will permit greater accuracy, and exhibit less ambient temperature dependence (for example by using one external transistor). These circuits still use an AC sensing circuit, and therefore do not provide any additional loading on the DC power supply (see application note AN004)

9 APPLICATION CIRCUITS

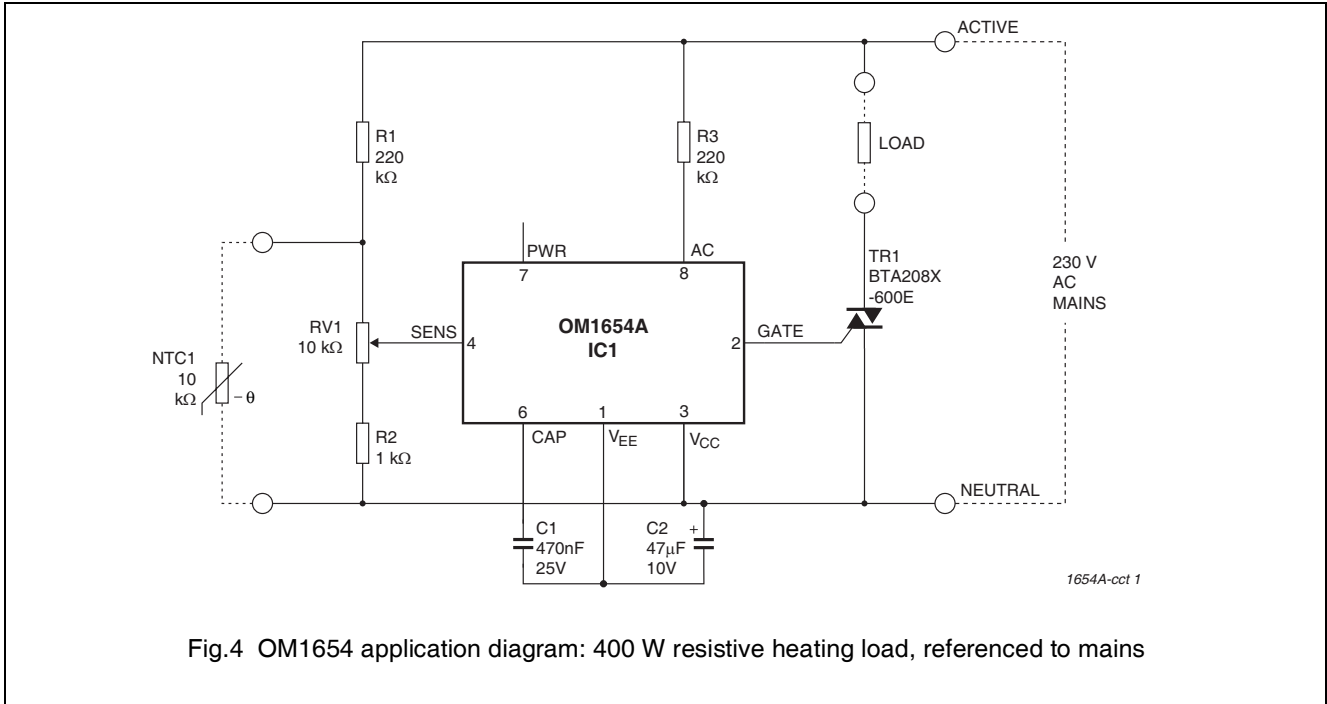

Fig.4 OM1654 application diagram: 400 W resistive heating load, referenced to mains

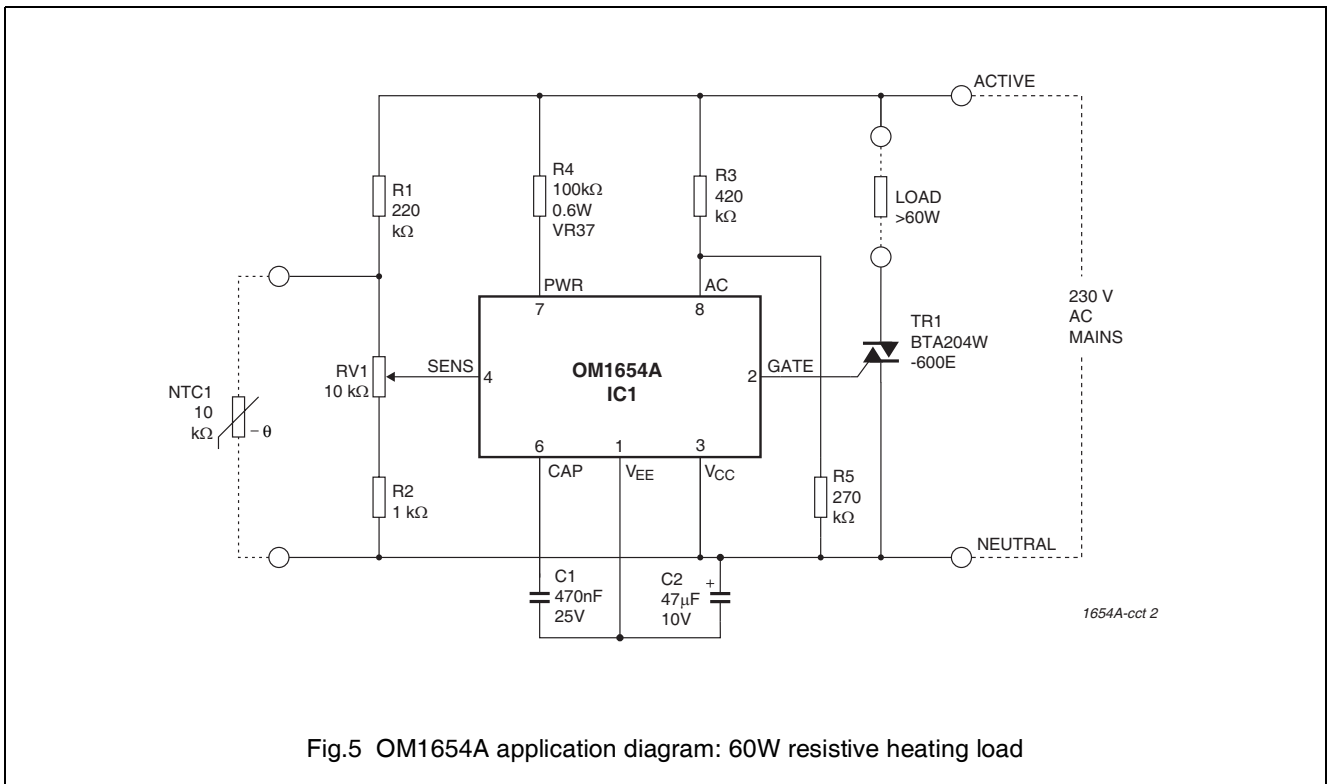
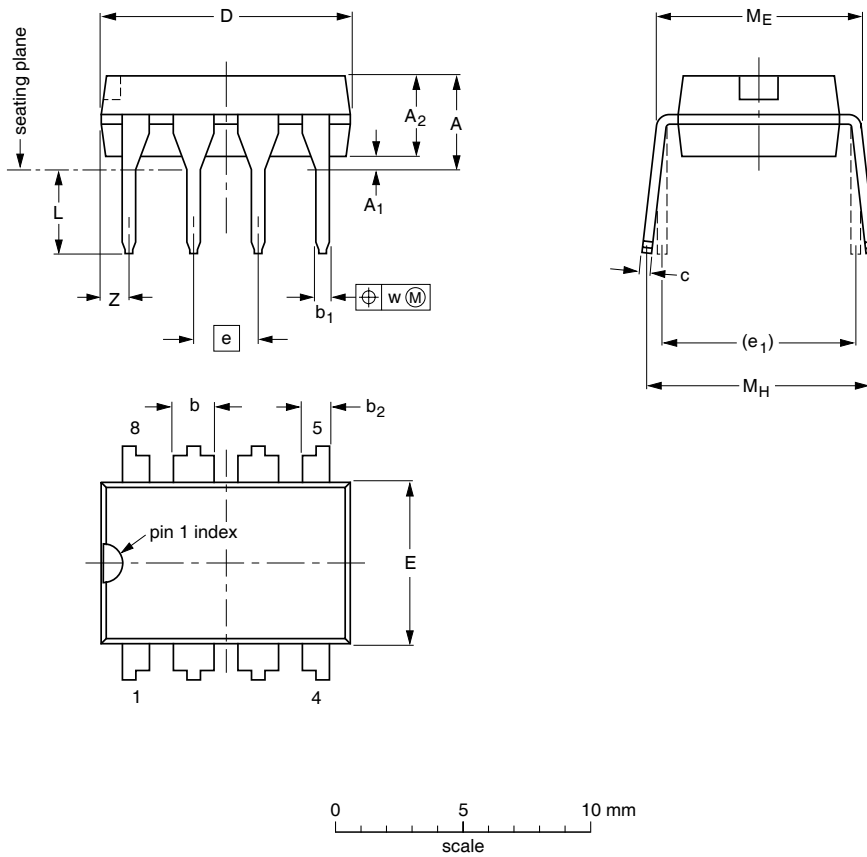

Fig.5 OM1654A application diagram: 60W resistive heating load

10 PACKAGE OUTLINES

DIP8: plastic dual in-line package; 8 leads (300 mil)

SOT97-1



DIMENSIONS (inch dimensions are derived from the original mm dimensions)

UNIT	A max.	A ₁ min.	A ₂ max.	b	b ₁	b ₂	c	D ⁽¹⁾	E ⁽¹⁾	e	e ₁	L	M _E	M _H	w	Z ⁽¹⁾ max.
mm	4.2	0.51	3.2	1.73 1.14	0.53 0.38	1.07 0.89	0.36 0.23	9.8 9.2	6.48 6.20	2.54	7.62	3.60 3.05	8.25 7.80	10.0 8.3	0.254	1.15
inches	0.17	0.020	0.13	0.068 0.045	0.021 0.015	0.042 0.035	0.014 0.009	0.39 0.36	0.26 0.24	0.10	0.30	0.14 0.12	0.32 0.31	0.39 0.33	0.01	0.045

Note

1. Plastic or metal protrusions of 0.25 mm maximum per side are not included.

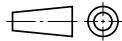
OUTLINE VERSION	REFERENCES				EUROPEAN PROJECTION	ISSUE DATE
	IEC	JEDEC	EIAJ			
SOT97-1	050G01	MO-001AN				92-11-17 95-02-04

S08: plastic small outline package; 8 leads; body width 3.9 mm

SOT96-1

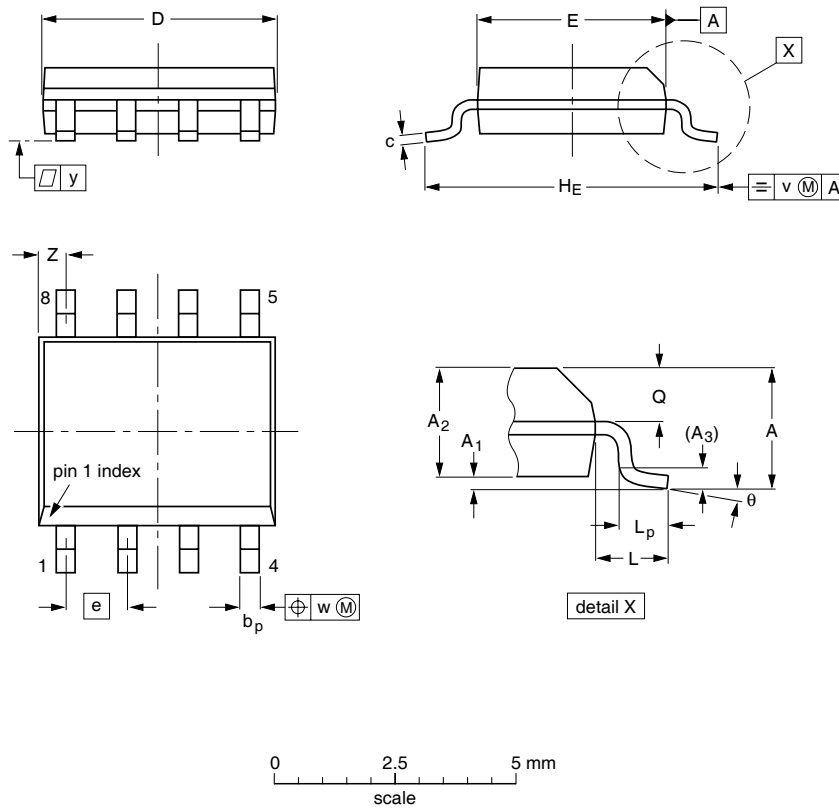

DIMENSIONS (inch dimensions are derived from the original mm dimensions)

UNIT	A ⁽¹⁾ max.	A ₁	A ₂	A ₃	b _p	c	D ⁽¹⁾	E ⁽²⁾	e	H _E	L	L _p	Q	v	w	y	Z ⁽¹⁾	θ
mm	1.75	0.25 0.10	1.45 1.25	0.25	0.49 0.36	0.25 0.19	5.0 4.8	4.0 3.8	1.27	6.2 5.8	1.05	1.0 0.4	0.7 0.6	0.25	0.25	0.1	0.7 0.3	8° 0°
inches	0.069	0.010 0.004	0.057 0.049	0.01	0.019 0.014	0.010 0.0075	0.20 0.19	0.16 0.15	0.050	0.244 0.228	0.041	0.039 0.016	0.028 0.024	0.01	0.01	0.004	0.028 0.012	

Notes

1. Plastic or metal protrusions of 0.15 mm maximum per side are not included.
2. Plastic or metal protrusions of 0.25 mm maximum per side are not included.

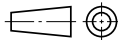
OUTLINE VERSION	REFERENCES				EUROPEAN PROJECTION	ISSUE DATE
	IEC	JEDEC	EIAJ			
SOT96-1	076E03S	MS-012AA				95-02-04 97-05-22

11 ORDERING INFORMATION

TYPE NUMBER	PACKAGE		
	NAME	DESCRIPTION	VERSION
OM1654A P	DIP8	plastic dual in-line package; 8 leads (300 mil)	SOT97-1
OM1654A T	SO8	plastic small outline package; 8 leads; body width 3.9 mm	SOT96-1

1. NOTE:

The OM1654A replaces the OM1654. In operation it is identical however the OM1654A has one extra pin connection (i.e. PWR, pin 7). Care needs to be taken with older designs using OM1654 where the PCB layout may make use of a pin 7 connection for other purposes in the layout.

12 ESD CAUTION

Electrostatic Discharge (ESD) sensitive device. ESD can cause permanent damage or degradation in the performance of this device. This device contains ESD protection structures aimed at minimising the impact of ESD. However, it is the users responsibility to ensure that proper ESD precautions are observed during the handling, placement and operation of this device.



13 DOCUMENT HISTORY

REVISION	DATE	DESCRIPTION
1.0	19990915	Released version
2.0	20021108	Add OM1654"A"
3.0	20050224	Remove reference to non-A part
4.0	20070213	HS formatting, standard ESD caution

14 DEFINITIONS

Data sheet status	
Engineering sample information	This contains draft information describing an engineering sample provided to demonstrate possible function and feasibility. Engineering samples have no guarantee that they will perform as described in all details.
Objective specification	This data sheet contains target or goal specifications for product development. Engineering samples have no guarantee that they will function as described in all details.
Preliminary specification	This data sheet contains preliminary data; supplementary data may be published later. Products to this data may not yet have been fully tested, and their performance fully documented.
Product specification	This data sheet contains final product specifications.
Limiting values	
Limiting values given are in accordance with the Absolute Maximum Rating System (IEC 134). Stress above one or more of the limiting values may cause permanent damage to the device. These are stress ratings only and operation of the device at these or at any other conditions above those given in the Characteristics sections of the specification is not implied. Exposure to limiting values for extended periods may affect device reliability.	
Application information	
Where application information is given, it is advisory and does not form part of the specification.	

15 COMPANY INFORMATION

HENDON SEMICONDUCTORS a trading name of INTEGRATED ELECTRONIC SOLUTIONS PTY. LTD.
 ABN 17 080 879 616

Postal address:

Hendon Semiconductors
 PO Box 2226
 Port Adelaide SA 5015
 AUSTRALIA

Street Address:

Hendon Semiconductors
 1 Butler Drive
 Hendon SA 5014
 AUSTRALIA

Telephone: +61 8 8348 5200

Facsimile: +61 8 8243 1048

World Wide Web: www.hendonsemiconductors.com
www.bus-buffer.com

Email: ies@ies-sa.com.au

16 DISCLAIMER

Integrated Electronic Solutions Pty. Ltd. ABN 17 080 879 616 trading as Hendon Semiconductors (“Hendon”) reserves the right to make changes to both its products and product data without notice.

Hendon makes no warranty, representation or guarantee regarding the suitability of its products for any particular purpose, nor does Hendon assume any liability arising out of the use or application of any Hendon product. Hendon specifically disclaims any and all liability, including without limitation incidental or consequential damages. It is the responsibility of the customer to ensure that in all respects the application in which Hendon goods are used is suited to the purpose of the end user.

Typical performance figures, where quoted may depend on the application and therefore must be validated by the customer in each particular application. It is the responsibility of customers to ensure that any designs using Hendon products comply with good practice, applicable standards and approvals. Hendon accepts no responsibility for incorrect or non-compliant use of its products, failure to meet appropriate standards and approvals in the application of Hendon products, or for the correct engineering choice of other connected components, layout and operation of Hendon products.

Any customer purchasing or using Hendon product(s) for an unintended or unauthorised application shall indemnify and hold Hendon and its officers, employees, related companies, affiliates and distributors harmless against all claims, costs, damages, expenses, and reasonable legal fees arising out of, directly or indirectly, any claim of loss, personal injury or death associated with such unintended or unauthorised use, even if such claim alleges that Hendon was negligent regarding the design or manufacture of the relevant product(s).

Life Support Applications

Products of Hendon Semiconductors (Hendon) are not designed for use in life support appliances, devices or systems, where malfunction can result in personal injury. Customers using or selling Hendon products for use in such applications do so at their own risk and agree to fully indemnify Hendon for any damages resulting from such improper use or sale.

