



# XWAY™ PHY11G

## 10/100/1000 Mbps PHY with SerDes and DC/DC Regulator

### Ethernet Features

- Energy-Efficient Ethernet:
  - 10BASE-Te
  - 100BASE-TX
  - 1000BASE-T
  - Wake-on-LAN
  - Auto Power-Down Modes
- Jumbo Frames of up to 10 kB
- Cable Diagnostics
- Auto-Downspeed
- Wiring Fault Tolerant:
  - Auto-MDI/MDI-X
  - Auto Polarity Correction
- Copper + Fiber Applications:
  - Single-Media
  - Dual-Media
  - Media Converter
- RGMII v1.3 and v2.0 MAC interface with Delay Compensation (RGMII-ID)
- Standards:
  - IEEE 802.3-2008 (relevant clauses)
  - IEEE 802.3az (Energy-Efficient Ethernet)
  - ANSIX3.263-1995
  - IEEE 1149.1

### Main Features

- Full-Duplex and Half-Duplex modes for 10BASE-T(e), 100BASE-TX, 1000BASE-T and 1000BASE-X
- Low-EMI linedriver with integrated line termination
- Single power supply at 2.5 - 3.3 V using the integrated DC/DC Switching Regulator
- Industry's smallest footprint using the VQFN48 (reduced xMII only) or LQFP64 package variants
- Ultra-low power consumption of typically 400 mW

The XWAY™ PHY11G family of Physical Layer (PHY) ICs incorporates a set of single Gigabit-Ethernet (GbE) PHY devices that support the 10BASE-T(e), 100BASE-TX, 1000BASE-T and 1000BASE-X standards in both the half-duplex and full-duplex modes. The performance requirements set by these standards are exceeded by the XWAY™ PHY11G family. Implementation of an integrated SerDes allows for support of 1000BASE-X and SGMII.

The XWAY™ PHY11G family is characterized by an ultra-low power consumption of 400 mW in 1000BASE-T mode. Support of Energy-Efficient Ethernet allows for an even further reduction in power consumption that depends on link utilization. Power savings at system level are introduced using the Wake-on-LAN feature. The comprehensive design of the ICs integrates support for single-media, dual-media and media-conversion applications for both copper and fiber media. In applications using the copper medium, the low-EMI line driver with integrated termination facilitates a simplified PCB design. The PHY devices are available in the VQFN48 and LQFP64 small-package variants, thereby setting a new benchmark in footprint minimization. Both package types support the RMII, RGMII interface types, while the latter additionally supports GMII.

Optionally, the devices can be operated from a single power supply, with a range of 2.5 V to 3.3 V by using the integrated DC/DC switching regulator with minimal external cost. The XWAY™ PHY11G devices are configurable via pin-strapping, by means of the MDIO interface, or optionally by connecting an external EEPROM.

### Applications

- Broadband Appliances:
  - xDSL Routers and PON Routers
- Home Gateway:
  - Home Server, Home Storage (NAS)
  - Gigabit SMB/SOHO Routers
- IP Phone
- Consumer Applications:
  - IPTV, Set-Top Boxes, Game Consoles
  - Printers
- Media Converter (Copper to Fiber)

# XWAY™ PHY11G

10/100/1000 Mbps PHY with SerDes and DC/DC Regulator

## XWAY™ PHY11G Application Example

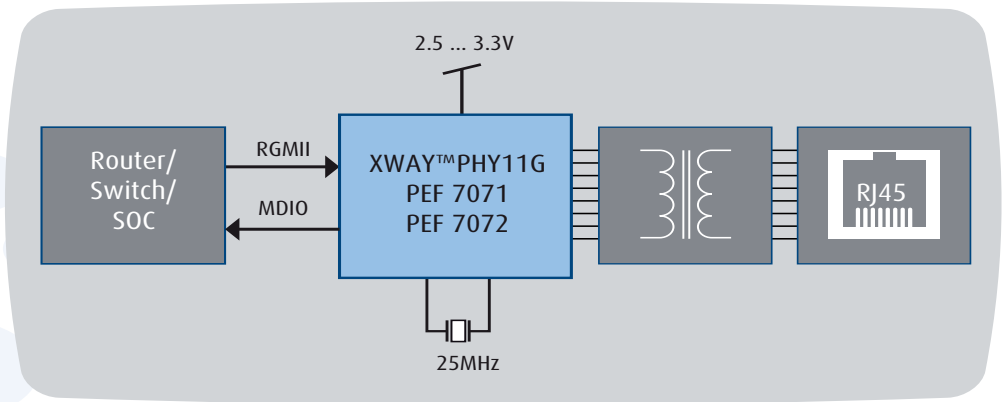

## XWAY™ PHY11G Block Diagram

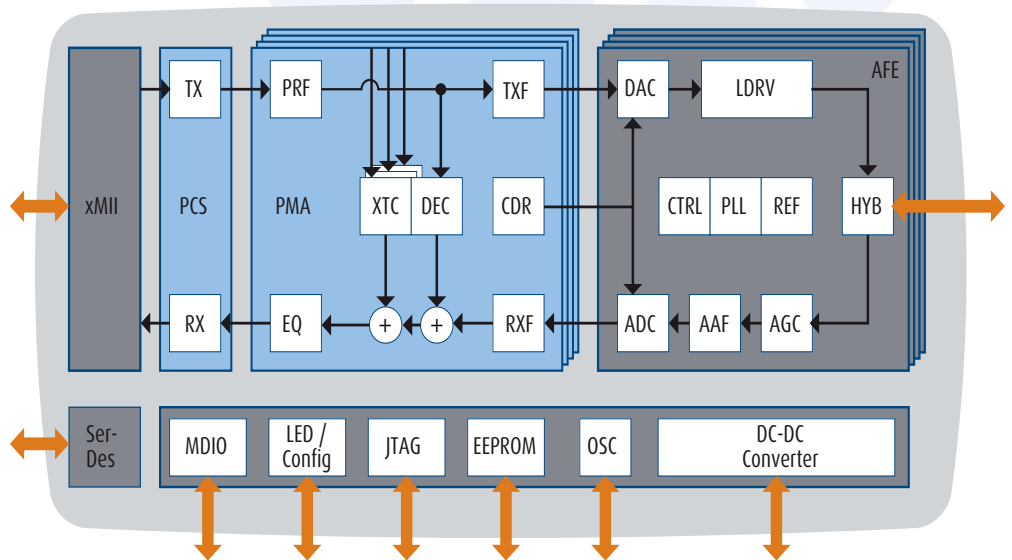

## Product Summary

Product Name	Sales Code	Description	Package
XWAY™ PHY11G	PEF 7071	10/100/1000 Mbps Ethernet PHY with RMII, RGMII, and SGMII	PG-VQFN-48
XWAY™ PHY11G	PEF 7072	10/100/1000 Mbps Ethernet PHY with MII, RMII, GMII, RGMII and SGMII	PG-LQFP-64



How to reach us: <http://www.Lantiq.com>

Published by Lantiq  
85579 Neubiberg, Germany

© 2012 Lantiq. All Rights Reserved.

**Legal Disclaimer** The information given in this Product Brief shall in no event be regarded as a guarantee of conditions or characteristics. With respect to any examples or hints given herein, any typical values stated herein and/or any information regarding the application of the device, Lantiq hereby disclaims any and all warranties and liabilities of any kind, including without limitation, warranties of non-infringement of intellectual property rights of any third party.

**Information** For further information on technology, delivery terms and conditions and prices, please contact the nearest Lantiq Office ([www.Lantiq.com](http://www.Lantiq.com)).

**Warnings** Due to technical requirements, components may contain dangerous substances. For information on the types in question, please contact the nearest Lantiq Office. Lantiq components may be used in life-support devices or systems only with the express written approval of Lantiq, if a failure of such components can reasonably be expected to cause the failure of that life-support device or system or to affect the safety or effectiveness of that device or system. Life support devices or systems are intended to be implanted in the human body or to support and/or maintain and sustain and/or protect human life. If they fail, it is reasonable to assume that the health of the user or other persons may be endangered.

Order Number: PB-e-0019-v3