

**FEATURES AND BENEFITS**

- Round, radial mounting design for easy surface mount
- Over 500,000 cycles
- 10 year life capability
- Ultra-low internal resistance

**TYPICAL APPLICATIONS**

- Industrial power back up
- Portable tool
- Renewable energy systems
- Short term UPS (uninterruptible power supply) and telecom applications



**PRODUCT SPECIFICATIONS**

ELECTRICAL	BCAP0310	BCAP0350
Rated Capacitance <sup>1</sup>	310 F	350 F
Minimum Capacitance, initial <sup>1</sup>	310 F	350 F
Maximum ESR <sub>DC</sub> , initial <sup>1</sup>	2.2 mΩ	3.2 mΩ
Rated Voltage	2.70 V	2.70 V
Absolute Maximum Voltage <sup>11</sup>	2.85 V	2.85 V
Maximum Continuous Current (ΔT = 15°C) <sup>2</sup>	25 A <sub>RMS</sub>	21 A <sub>RMS</sub>
Maximum Continuous Current (ΔT = 40°C) <sup>2</sup>	41 A <sub>RMS</sub>	34 A <sub>RMS</sub>
Maximum Peak Current, 1 second (non repetitive) <sup>3</sup>	250 A	220 A
Leakage Current, maximum <sup>4</sup>	0.45 mA	0.30 mA
TEMPERATURE		
Operating temperature range (Cell case temperature)		
Minimum	-40°C	-40°C
Maximum	65°C	65°C
Storage temperature range (Stored uncharged)		
Minimum	-40°C	-40°C
Maximum	70°C	70°C
PHYSICAL		
Mass, typical	60 g	60 g
Terminals	Radial Tab	Radial Tab
Vibration	IEC 60068.2.6, SAE J2380	IEC 60068.2.6, SAE J2380
Shock	IEC 60068.2.27, SAE J2464	IEC 60068.2.27, SAE J2464

## PRODUCT SPECIFICATIONS (Cont'd)

## POWER &amp; ENERGY

	BCAP0310	BCAP0350
Usable Specific Power, $P_d^5$	6,600 W/kg	4,600 W/kg
Impedance Match Specific Power <sup>6</sup>	14,000 W/kg	9,500 W/kg
Specific Energy, $E_{max}^7$	5.2 Wh/kg	5.9 Wh/kg
Stored Energy <sup>8</sup>	0.31 Wh	0.35 Wh

## LIFE

<b>High Temperature<sup>1</sup></b> (at Rated Voltage & Maximum Operating Temperature)	1,500 hours	1,500 hours
Capacitance Change (% decrease from minimum initial value)	20%	20%
ESR Change (% increase from maximum initial value)	100%	100%
<b>Room Temperature<sup>1</sup></b> (at Rated Voltage & 25°C)	10 years	10 years
Capacitance Change (% decrease from minimum initial value)	20%	20%
ESR Change (% increase from maximum initial value)	100%	100%
<b>Cycle Life<sup>1,9</sup></b>	500,000 cycles	500,000 cycles
Capacitance Change (% decrease from minimum initial value)	20%	20%
ESR Change (% increase from maximum initial value)	100%	100%
Test Current	31 A	35 A
<b>Shelf Life<sup>1,10</sup></b> (Stored uncharged up to a maximum storage temperature)	2 years	2 years

## SAFETY

Short Circuit Current, typical (Current possible with short circuit from rated voltage. Do not use as an operating current.)	1,200 A	840 A
Certifications	UL810a, RoHS	UL810a, RoHS

## TYPICAL CHARACTERISTICS

### THERMAL CHARACTERISTICS

	BCAP0310	BCAP0350
Thermal Resistance ( $R_{th}$ , Case to Ambient), typical <sup>2</sup>	10.9°C/W	10.9°C/W
Thermal Capacitance ( $C_{th}$ ), typical <sup>2</sup>	60 J/°C	60 J/°C

### ESR AND CAPACITANCE VS TEMPERATURE

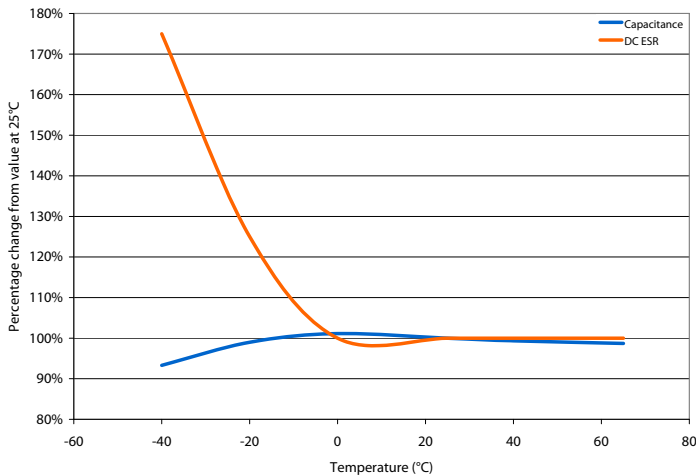

### NOTES

1. Capacitance and  $ESR_{DC}$  measured at 25°C per Document Number 1007239 available at [www.maxwell.com](http://www.maxwell.com).
2. Per Maxwell Document 1007239 available at [www.maxwell.com](http://www.maxwell.com).
3. Maximum Peak current (1 sec) =  $\frac{1/2 CV}{C \times ESR_{DC} + 1}$
4. After 72 hours at 25°C and rated voltage. Initial leakage current can be higher.
5. Per IEC 62391-2,  $P_d = \frac{0.12V^2}{ESR_{DC} \times mass}$
6.  $P_{max} = \frac{V^2}{4 \times ESR_{DC} \times mass}$
7.  $E_{max} = \frac{1/2 CV^2}{3,600 \times mass}$
8.  $E_{stored} = \frac{1/2 CV^2}{3,600}$
9. Cycle per Document Number 1007239 available at [www.maxwell.com](http://www.maxwell.com).
10. No more than 10% decrease in capacitance from minimum initial capacitance or 50% increase in ESR from maximum initial ESR.
11. Absolute maximum voltage non repeated, not to exceed 1 second.

### MOUNTING RECOMMENDATIONS

Do not reverse polarity. Please refer to document number 1008238, available at [maxwell.com](http://maxwell.com) for soldering recommendations.

### MARKINGS

Products are marked with the following information: Rated capacitance, rated voltage, product number, name of manufacturer, positive and negative terminal, warning marking, serial number.

BCAP0350 E270 T11

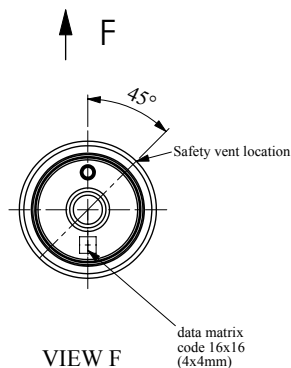
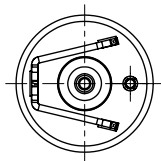
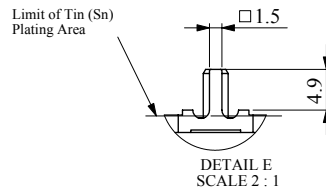
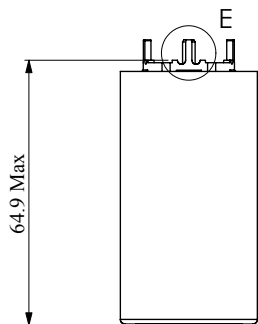
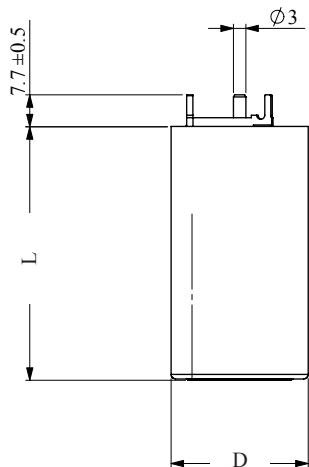

Board drillings  
Board thickness : 1.5 to 3.2 mm

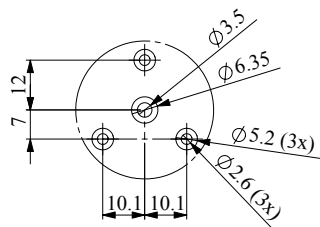

Part Description	Dimensions (mm)		Package Quantity
	L (max)	D (max)	
BCAP0350 E270 T11	61.5	33.3	250

Product dimensions are for reference only unless otherwise identified. Product dimensions and specifications may change without notice. Please contact Maxwell Technologies directly for any technical specifications critical to application.

BCAP0310 P270 T10

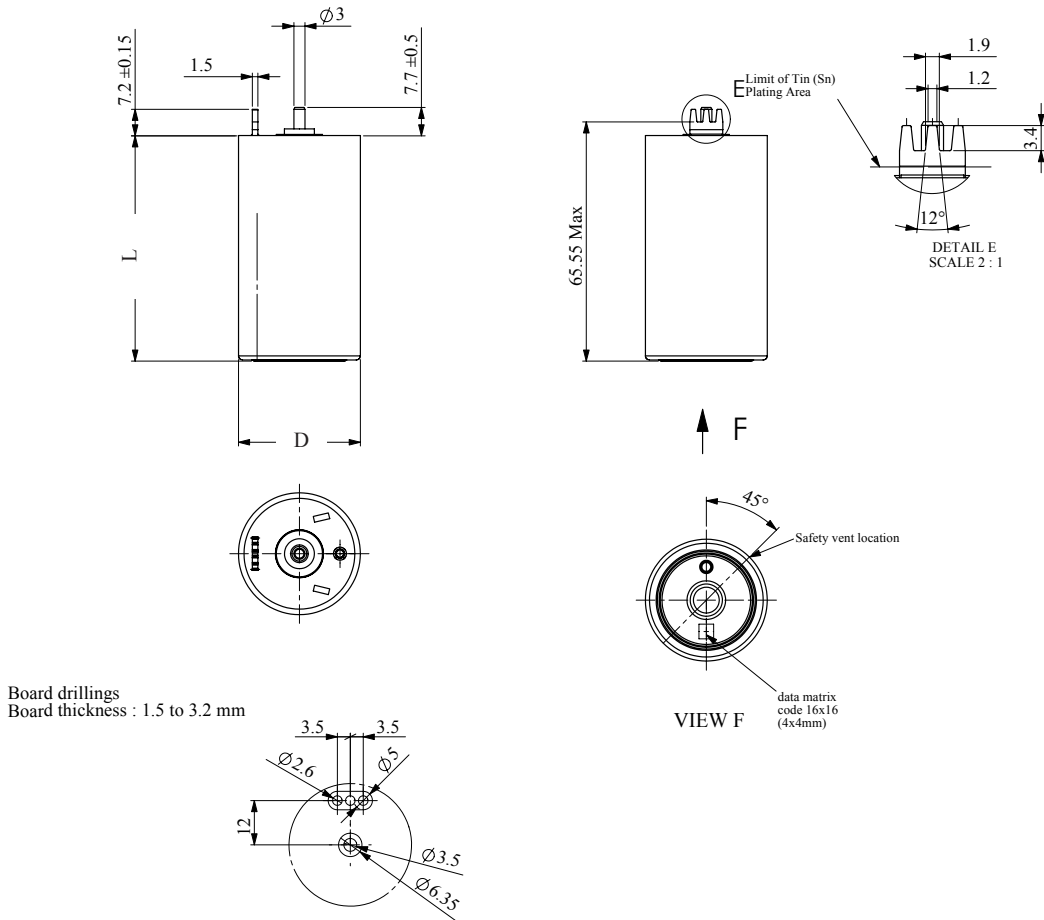

Part Description	Dimensions (mm)		Package Quantity
	L (max)	D (max)	
BCAP0310 P270 T10	61.5	33.3	250

Product dimensions are for reference only unless otherwise identified. Product dimensions and specifications may change without notice. Please contact Maxwell Technologies directly for any technical specifications critical to application. All products featured on this datasheet are covered by the following U.S. patents and their respective foreign counterparts: 7511941, 7307830, 6.842.330, 7.352.558, 7.295.426, 7.090.946, 7.508.651, 7.492.571, 7.342.770, 6.643.119, 7.384.433, 7.147.674, 7.317.609, 7.495.349, 7.102.877, 6.631.074, 6.804.108, 6.813.139.



**Maxwell Technologies, Inc.**  
**Global Headquarters**  
 5271 Viewridge Court, Suite 100  
 San Diego, CA 92123  
 USA  
 Tel: +1 858 503 3300  
 Fax: +1 858 503 3301



**Maxwell Technologies SA**  
 CH-1728 Rossens  
 Switzerland  
 Tel: +41 (0)26 411 85 00  
 Fax: +41 (0)26 411 85 05



**Maxwell Technologies, GmbH**  
 Brucker Strasse 21  
 D-82205 Gilching  
 Germany  
 Tel: +49 (0)8105 24 16 16  
 Fax: +49 (0)8105 24 16 19



**Maxwell Technologies, Inc.**  
**Shanghai Representative Office**  
 13E, CR Times Square  
 500 Zhangyang Road, Pudong  
 Shanghai 200122, P.R. China  
 Tel: +86 21 5836 8780  
 Fax: +86 21 5836 8790