

FEATURES AND BENEFITS

- Ultra-low internal resistance
- Highest power performance available
- Over 1,000,000 duty cycles
- Compact, rugged, fully enclosed splash proof design

TYPICAL APPLICATIONS

- Automotive
- Industrial
- Telecommunications
- Transportation
- Uninterruptible Power Supplies (UPS)
- Wind turbines



PRODUCT SPECIFICATIONS

ELECTRICAL

	BMOD0500 B01	BMOD0500 B02
Rated Capacitance ¹	500 F	500 F
Minimum Capacitance, initial ¹	500 F	500F
Maximum ESR _{DC} , initial ¹	2.1 mΩ	2.1 mΩ
Rated Voltage	16 V	16 V
Absolute Maximum Voltage ¹⁴	17 V	17 V
Maximum Continuous Current (ΔT = 15°C) ²	100 A _{RMS}	100 A _{RMS}
Maximum Continuous Current (ΔT = 40°C) ²	160 A _{RMS}	160 A _{RMS}
Maximum Peak Current, 1 second (non repetitive) ³	2,000 A	2,000 A
Leakage Current, maximum (B01 Suffix - VMS 2.0) ⁴	5.2 mA	N/A
Leakage Current, maximum (B02 Suffix - Passive Balancing) ⁴	N/A	170 mA
Maximum Series Voltage	750 V	750 V

TEMPERATURE

Operating Temperature (Ambient temperature)		
Minimum	-40°C	-40°C
Maximum	65°C	65°C
Storage Temperature (Stored uncharged)		
Minimum	-40°C	-40°C
Maximum	70°C	70°C

PRODUCT SPECIFICATIONS (Cont'd)

PHYSICAL

	BMOD0500 B01	BMOD0500 B02
Mass, typical	5.51 kg	5.51 kg
Power Terminals	M8/M10	M8/M10
Recommended Torque - Terminal	20/30 Nm	20/30 Nm
Vibration Specification	SAE J2380	SAE J2380
Shock Specification	SAE J2464	SAE J2464
Environmental Protection	IP65	IP65
Cooling	Natural Convection	Natural Convection

MONITORING / CELL VOLTAGE MANAGEMENT

Internal Temperature Sensor	NTC Thermistor	NTC Thermistor
Temperature Interface	Analog	Analog
Cell Voltage Monitoring	Overvoltage Alarm	-
Connector	Deutsch DTM	Deutsch DTM
Cell Voltage Management	VMS 2.0	Passive

POWER & ENERGY

Usable Specific Power, P_d^5	2,700 W/kg	2,700 W/kg
Impedance Match Specific Power, P_{max}^6	5,500 W/kg	5,500 W/kg
Specific Energy, E_{max}^7	3.2 Wh/kg	3.2 Wh/kg
Stored Energy ⁸	17.8 Wh	17.8 Wh

LIFE

High Temperature ¹ (at Rated Voltage & Maximum Operating Temperature)	1,500 hours	1,500 hours
Capacitance Change (% decrease from minimum initial value)	20%	20%
ESR Change (% increase from maximum initial value)	100%	100%
Room Temperature ¹ (at Rated Voltage & 25°C)	10 years	10 years
Capacitance Change (% decrease from minimum initial value)	20%	20%
ESR Change (% increase from maximum initial value)	100%	100%
Cycle Life ^{1,9}	1,000,000 cycles	1,000,000 cycles

PRODUCT SPECIFICATIONS (Cont'd)

BMOD0500 B01

BMOD0500 B02

Capacitance Change (% decrease from minimum initial value)	20%	20%
ESR Change (% increase from maximum initial value)	100%	100%
Test Current	100 A	100 A
Shelf Life ^{1,10} (Stored uncharged up to a maximum storage temperature)	2 years	2 years

SAFETY

Short Circuit Current, typical (Current possible with short circuit from rated voltage. Do not use as an operating current.)	7,600 A	7,600 A
Factory High-Pot Test ¹³	2,500 V DC	2,500 V DC
Certifications	RoHS UL810a (150 V)	RoHS UL810a (150 V)

TYPICAL CHARACTERISTICS

THERMAL CHARACTERISTICS

Thermal Resistance (R_{cm} , One Cell Case to Module Case), typical ²	1.0°C/W	1.0°C/W
Thermal Resistance (R_{ma} , Module Case to Ambient), typical	0.45°C/W	0.45°C/W
Thermal Resistance (R_{ca} , All Cell Cases to Ambient), typical	0.70°C/W	0.70°C/W
Thermal Capacitance (C_{th}), typical ²	4,280 J/°C	4,280 J/°C

ESR AND CAPACITANCE VS TEMPERATURE

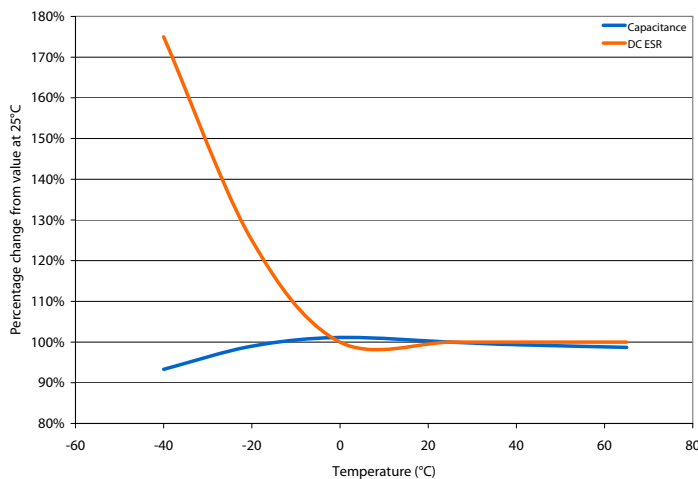

NOTES

1. Capacitance and ESR_{DC} measured at 25°C per Document Number 1007239 available at www.maxwell.com.
2. Per Maxwell Document 1007239 available at www.maxwell.com.
3. Maximum Peak current (1 sec) = $\frac{1/2 CV}{C \times ESR_{DC} + 1}$
4. After 72 hours at 25°C and rated voltage. Initial leakage current can be higher.
5. Per IEC 62391-2, $P_d = \frac{0.12V^2}{ESR_{DC} \times \text{mass}}$
6. $P_{\text{max}} = \frac{V^2}{4 \times ESR_{DC} \times \text{mass}}$
7. $E_{\text{max}} = \frac{1/2 CV^2}{3,600 \times \text{mass}}$
8. $E_{\text{stored}} = \frac{1/2 CV^2}{3,600}$
9. Cycle per Document Number 1007239 available at www.maxwell.com.
10. No more than 10% decrease in capacitance from minimum initial capacitance or 50% increase in ESR from maximum initial ESR.
11. Tested at 1 kV DC.
12. For a given application, sufficient cooling must be provided to keep cell case temperatures below 65°. See R_{th} .
13. Duration = 60 seconds. Not intended as an operating parameter.
14. Absolute maximum voltage non repeated, not to exceed 1 second.

MOUNTING RECOMMENDATIONS

Please refer to the user manual for installation recommendations.

MARKINGS

Products are marked with the following information: Rated capacitance, rated voltage, product number, name of manufacturer, positive and negative terminal, warning marking, serial number.

BMOD0500 P016 B0x

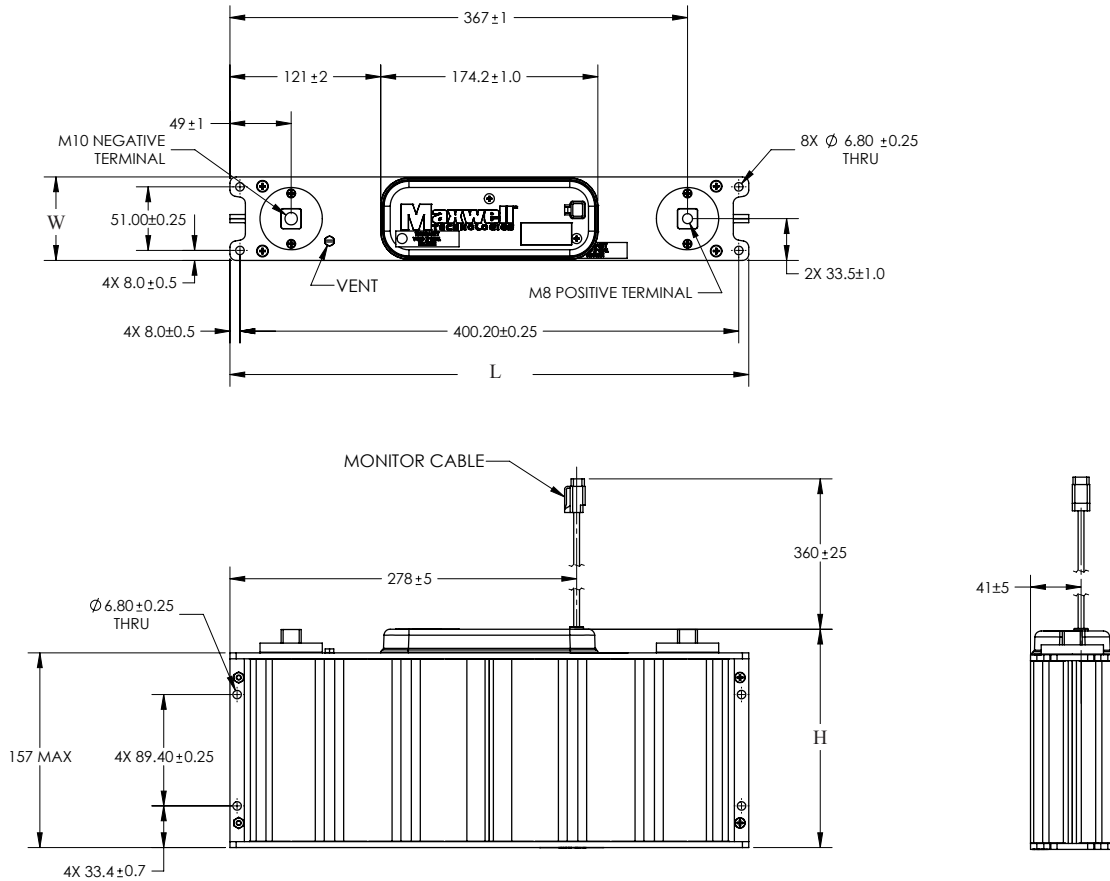

Part Description	Dimensions (mm)			Package Quantity
	L (max)	W (max)	H (max)	
BMOD0500 P016 B01/B02	418	68	179	3

Product dimensions are for reference only unless otherwise identified. Product dimensions and specifications may change without notice. Please contact Maxwell Technologies directly for any technical specifications critical to application. All products featured on this datasheet are covered by the following U.S. patents and their respective foreign counterparts: 7511942, 7307830, 7203056, 7180726, 7027290, 7.352.558, 7.295.423, 7.090.946, 7.508.651, 7.492.571, 7.342.770, 6.643.119, 7.384.433, 7.147.674, 7.317.609, 7.495.349, 7.102.877.



Maxwell Technologies, Inc.
Global Headquarters
 5271 Viewridge Court, Suite 100
 San Diego, CA 92123
 USA
 Tel: +1 858 503 3300
 Fax: +1 858 503 3301



Maxwell Technologies SA
 CH-1728 Rossens
 Switzerland
 Tel: +41 (0)26 411 85 00
 Fax: +41 (0)26 411 85 05



Maxwell Technologies, GmbH
 Brucker Strasse 21
 D-82205 Gilching
 Germany
 Tel: +49 (0)8105 24 16 16
 Fax: +49 (0)8105 24 16 19



Maxwell Technologies, Inc.
Shanghai Representative Office
 13E, CR Times Square
 500 Zhangyang Road, Pudong
 Shanghai 200122, P.R. China
 Tel: +86 21 5836 8780
 Fax: +86 21 5836 8790