

## FEATURES AND BENEFITS

- Compact, rugged, fully enclosed splash proof design
- Highest power performance available
- Individually balanced cells
- Over 1,000,000 duty cycles
- Ultra-low internal resistance
- Voltage & temperature sensor output included

## TYPICAL APPLICATIONS

- Automotive
- Industrial
- Telecommunications
- Bus, Train
- Uninterruptible Power Supplies (UPS)



## PRODUCT SPECIFICATIONS

## ELECTRICAL

	BMOD0083 P048 B01	BMOD0165 P048 BXX
Rated Capacitance <sup>1</sup>	83 F	165 F
Minimum Capacitance, initial <sup>1</sup>	83 F	165 F
Maximum Capacitance, initial <sup>1</sup>	100 F	200 F
Maximum ESR <sub>DC</sub> , initial <sup>1</sup>	10 mΩ	6.3 mΩ
Test Current for Capacitance and ESR <sub>DC</sub> <sup>1</sup>	100 A	100 A
Rated Voltage	48 V	48 V
Absolute Maximum Voltage <sup>3</sup>	51 V	51 V
Absolute Maximum Current	1150 A	1900 A
Leakage Current at 25°C, maximum <sup>4</sup>	3 mA	5.2 mA
Maximum Series Voltage	750 V	750 V
Capacitance of Individual Cells <sup>11</sup>	1500 F	3000 F
Stored Energy, Individual Cell <sup>11</sup>	1.5 Wh	3.0 Wh
Number of Cells	18	18

## TEMPERATURE

Operating Temperature (Cell Case Temperature)		
Minimum	-40°C	-40°C
Maximum	65°C	65°C
Storage Temperature (Stored Uncharged)		
Minimum	-40°C	-40°C
Maximum	70°C	70°C

## PRODUCT SPECIFICATIONS (Cont'd)

## PHYSICAL

	BMOD0083 B01	BMOD0165 BXX
Mass, typical	10.3 kg	13.5 kg
Power Terminals	M8/M10	M8/M10
Recommended Torque - Terminal	20/30 Nm	20/30 Nm
Vibration Specification	SAE J2380	SAE J2380
Shock Specification	SAE J2464	SAE J2464
Environmental Protection	IP65	IP65
Cooling	Natural Convection	Natural Convection

## MONITORING / CELL VOLTAGE MANAGEMENT

	BMOD0083 B01	BMOD0165 BXX
Internal Temperature Sensor	NTC Thermistor	NTC Thermistor
Temperature Interface	Analog	Analog
Cell Voltage Monitoring	Overvoltage Alarm	Overvoltage Alarm
Connector	Deutsch DTM	Deutsch DTM
Cell Voltage Management	VMS 2.0	VMS 2.0

## POWER &amp; ENERGY

	BMOD0083 B01	BMOD0165 BXX
Usable Specific Power, $P_d^5$	2,700 W/kg	3,300 W/kg
Impedance Match Specific Power, $P_{max}^6$	5,600 W/kg	6,800 W/kg
Specific Energy, $E_{max}^7$	2.6 Wh/kg	3.9 Wh/kg
Stored Energy <sup>8</sup>	27 Wh	53 Wh

## SAFETY

	BMOD0083 B01	BMOD0165 BXX
Short Circuit Current, typical (Current possible with short circuit from rated voltage. Do not use as an operating current.)	4,800 A	7,600 A
Certifications	RoHS	RoHS, UL810a (B01 & B06 only, 150 Volts)
High-Pot Capability <sup>12</sup>	2,500 VDC	2,500 VDC

## TYPICAL CHARACTERISTICS

### THERMAL CHARACTERISTICS

	BMOD0083 B01	BMOD0165 BXX
Thermal Resistance ( $R_{ca}$ , All Cell Cases to Ambient), typical <sup>2</sup>	0.40°C/W	0.40°C/W
Thermal Capacitance ( $C_{th}$ ), typical	7,700 J/°C	13,000 J/°C
Maximum Continuous Current ( $\Delta T = 15\text{ °C}$ ) <sup>2</sup>	61 A <sub>RMS</sub>	77 A <sub>RMS</sub>
Maximum Continuous Current ( $\Delta T = 40\text{ °C}$ ) <sup>2</sup>	100 A <sub>RMS</sub>	130 A <sub>RMS</sub>

### LIFE

DC Life at High Temperature <sup>1</sup> (held continuously at Rated Voltage and Maximum Operating Temperature)	1,500 hours	1,500 hours
Capacitance Change (% decrease from minimum initial value)	20%	20%
ESR Change (% increase from maximum initial value)	100%	100%
Projected DC Life at 25°C <sup>1</sup> (held continuously at Rated Voltage)	10 years	10 years
Capacitance Change (% decrease from minimum initial value)	20%	20%
ESR Change (% increase from maximum initial value)	100%	100%
Projected Cycle Life at 25°C <sup>1,9,10</sup>	1,000,000 cycles	1,000,000 cycles
Capacitance Change (% decrease from minimum initial value)	20%	20%
ESR Change (% increase from maximum initial value)	100%	100%
Test Current	100 A	100 A
Shelf Life (Stored uncharged at 25°C)	4 years	4 years

### ESR AND CAPACITANCE VS TEMPERATURE

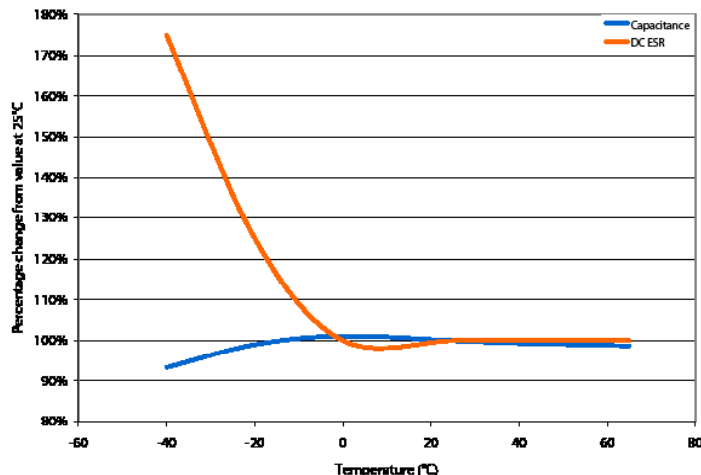

NOTES

1. Capacitance and  $ESR_{DC}$  measured at 25°C using specified test current per waveform below.
2.  $\Delta T = I_{RMS}^2 \times ESR \times R_{ca}$
3. Absolute maximum voltage, non-repeated. Not to exceed 1 second.
4. After 72 hours at rated voltage. Initial leakage current can be higher.

5. Per IEC 62391-2,  $P_d = \frac{0.12V^2}{ESR_{DC} \times mass}$

6.  $P_{max} = \frac{V^2}{4 \times ESR_{DC} \times mass}$

7.  $E_{max} = \frac{\frac{1}{2} CV^2}{3,600 \times mass}$

8.  $E_{stored} = \frac{\frac{1}{2} CV^2}{3,600}$

9. Cycle using specified test current per waveform below.
10. Cycle life varies depending upon application-specific characteristics. Actual results will vary.
11. Per United Nations material classification UN3499, all Maxwell ultracapacitors have less than 10 Wh capacity to meet the requirements of Special Provisions 361. Both individual ultracapacitors and modules composed of those ultracapacitors shipped by Maxwell can be transported without being treated as dangerous goods (hazardous materials) under transportation regulations.
12. Duration = 60 seconds. Not intended as an operating parameter.

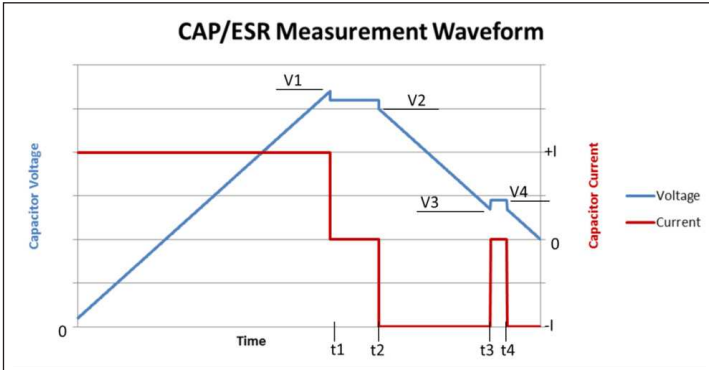

$V1 = V_{rated}$        $t2 - t1 = 15$  seconds      Capacitance =  $I \times (t3 - t2) / (V2 - V3)$   
 $V3 = 0.5 \times V_{rated}$        $t4 - t3 = 5$  seconds       $ESR = (V4 - V3) / I$

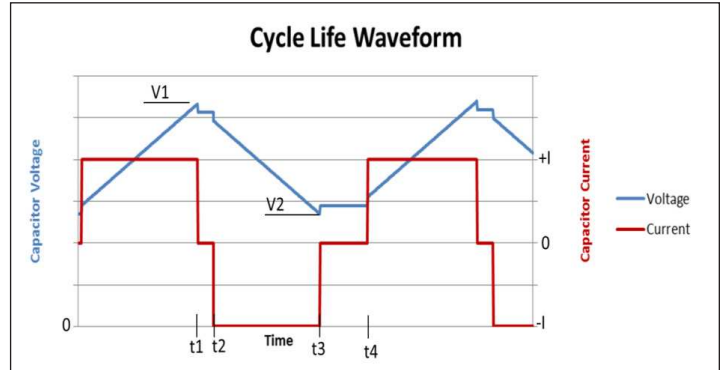

$V1 = V_{rated}$        $t2 - t1 = 5$  seconds ( $I=0$ )  
 $V2 = 0.5 \times V_{rated}$        $t4 - t3 = 15$  seconds ( $I=0$ )

MOUNTING RECOMMENDATIONS

Please refer to the user manual for installation recommendations.

MARKINGS

Products are marked with the following information: Rated capacitance, rated voltage, product number, name of manufacturer, positive and negative terminal, warning marking, serial number.

BMOD0083 P048 B01

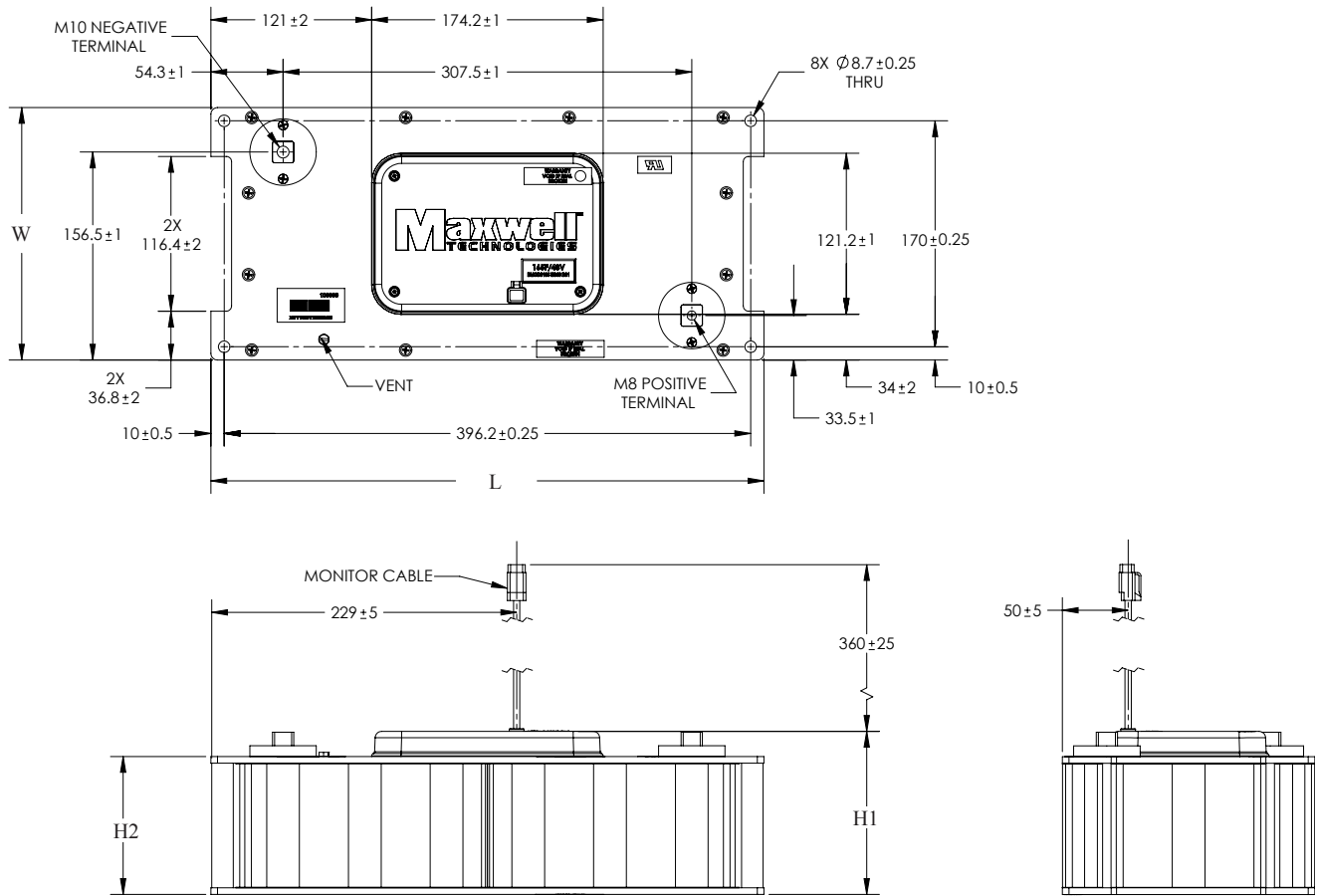

Part Description	Dimensions (mm)				Package Quantity
	L (max)	W (max)	H1 (max)	H2 (max)	
BMOD0083 P048 B01	418	191	126	106	1

Product dimensions are for reference only unless otherwise identified. Product dimensions and specifications may change without notice. Please contact Maxwell Technologies directly for any technical specifications critical to application.

**BMOD0165 P048 BXX**

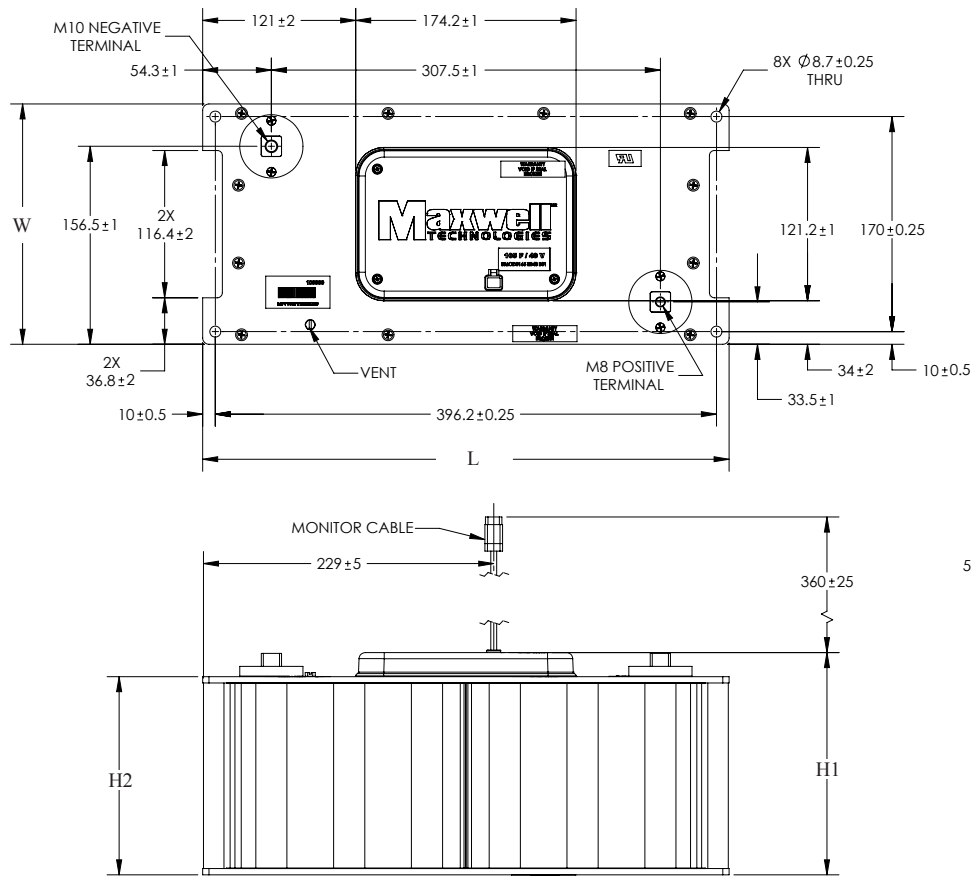

Part Description	Dimensions (mm)				Package Quantity
	L (max)	W (max)	H1 (max)	H2 (max)	
BMOD0165 P048 BXX*	418	194	179	157	1

\*Refer to user manual for product variant details.

Product dimensions are for reference only unless otherwise identified. Product dimensions and specifications may change without notice.

Please contact Maxwell Technologies directly for any technical specifications critical to application. All products featured on this datasheet are covered by the following U.S. patents and their respective foreign counterparts: 6643119, 7180726, 7295423, 7342770, 7352558, 7384433, 7440258, 7492571, 7508651, 7580243, 7791860, 7816891, 7816891, 7859826, 7883553, 7935155, 8072734, 8098481, 8279580.



**Maxwell Technologies, Inc.**  
**Global Headquarters**  
 3888 Calle Fortunada  
 San Diego, CA 92123  
 USA  
 Tel: +1 858 503 3300  
 Fax: +1 858 503 3301



**Maxwell Technologies SA**  
 Route de Montena 65  
 CH-1728 Rossens  
 Switzerland  
 Tel: +41 (0)26 411 85 00  
 Fax: +41 (0)26 411 85 05



**Maxwell Technologies, GmbH**  
 Leopoldstrasse 244  
 80807 München  
 Switzerland  
 Germany  
 Tel: +49 (0)89 / 4161403 0  
 Fax: +49 (0)89 / 4161403 99



**Maxwell Technologies, Inc.**  
**Shanghai Trading Co. Ltd.**  
 Unit A2BC, 12th Floor  
 Huarun Times Square  
 500 Zhangyang Road, Pudong  
 Shanghai 200122, P.R. China  
 Tel: 86 21 3852 4000  
 Fax: +86 21 3852 4099

MAXWELL TECHNOLOGIES, MAXWELL, MAXWELL CERTIFIED INTEGRATOR, ENABLING ENERGY'S FUTURE, BOOSTCAP, C CELL, D CELL and their respective designs and/or logos are either trademarks or registered trademarks of Maxwell Technologies, Inc. and may not be copied, imitated or used, in whole or in part, without the prior written permission from Maxwell Technologies, Inc. All contents copyright © 2013 Maxwell Technologies, Inc. All rights reserved. No portion of these materials may be reproduced in any form, or by any means, without prior written permission from Maxwell Technologies, Inc.

maxwell.com

