

FEATURES:

- A-Port outputs have equivalent 22- Ω series resistors, so no external resistors are required
- Support mixed-mode signal operation (5V input and output voltages with 3.3V V_{CC})
- Support unregulated battery operation down to 2.7V
- Typical V_{OLP} (output ground bounce) < 0.8V at $V_{CC} = 3.3V$, $T_A = 25^\circ C$
- I_{OFF} and power-up 3-state support hot insertion
- Bus hold on data inputs eliminates the need for external pullup/pulldown resistors
- Distributed V_{CC} and GND pin configuration minimizes high-speed switching noise
- Flow-through architecture optimizes PCB layout
- Total dose hardness:
- > 100 krad (Si), depending upon space mission
- Package: 48 pin RAD-PAK® flat pack

DESCRIPTION:

Maxwell Technologies' 54LVTH162245 devices are 16-bit (dual-octal) non-inverting 3-state transceivers designed for low-voltage (3.3V) V_{CC} operation, but with the capability to provide a TTL interface to a 5V system environment. These devices can be used as two 8-bit transceivers or one 16-bit transceiver. The devices allow data transmission from the A bus to the B bus or from the B bus to the A bus, depending on the logic level at the direction-control (DIR) input. The output enable (\overline{OE}) input can be used to disable the device so that the buses are effectively isolated. The A-port outputs, which are designed to source or sink up to 12 mA, include equivalent 22- Ω series resistors to reduce overshoot and undershoot.

Maxwell Technologies' patented RAD-PAK® packaging technology incorporates radiation shielding in the microcircuit package. It eliminates the need for box shielding while providing the required radiation shielding for a lifetime in orbit or space mission. In a GEO orbit, RAD-PAK provides greater than 100 krad (Si) radiation dose tolerance. This product is available with screening up to Class S.

TABLE 1. PINOUT DESCRIPTION

| PIN | SYMBOL | DESCRIPTION |
|--------------------------------|-----------------|-------------------|
| 1, 24 | 1DIR - 2DIR | Direction Control |
| 2, 3, 5, 6, 8, 9, 11, 12 | 1B1 - 1B8 | Output |
| 4, 10, 15, 21, 28, 34, 39, 45 | GND | Ground |
| 7, 18, 31, 42 | V _{CC} | Supply Voltage |
| 13, 14, 16, 17, 19, 20, 22, 23 | 2B - 2B8 | Output |
| 25, 48 | 2OE - 1OE | Output Enable |
| 26, 27, 29, 30, 32, 33, 35, 36 | 2A8 - 2A1 | Input |
| 37, 38, 40, 41, 43, 44, 46, 47 | 1A8 - 1A1 | Input |

TABLE 2. 54LVTH162245 ABSOLUTE MAXIMUM RATINGS ¹

| PARAMETER | SYMBOL | MIN | MAX | UNIT |
|---|--------------------------------------|------|-----------------------|------|
| Supply voltage range | V _{CC} | -0.5 | 4.6 | V |
| Input voltage range ² | V _I | -0.5 | 7 | V |
| Voltage range applied to any output in the high-impedance or power-off state ² | V _O | -0.5 | 7 | V |
| Voltage range applied to any output in the high state ² | V _O | -0.5 | V _{CC} + 0.5 | V |
| Current into any output in the low state B Port A Port | I _O | -- | 96 30 | mA |
| Current into any output in the high state ³ B Port A Port | I _O | -- | 48 30 | mA |
| Input clamp current | I _{IK} (V _I < 0) | -50 | -- | mA |
| Output clamp current | I _{OK} (V _O < 0) | -50 | -- | mA |
| Thermal resistance | Θ _{JC} | -- | 5 | °C/W |
| Operating temperature range | T _A | -55 | 125 | °C |
| Storage temperature range | T _S | -65 | 150 | °C |
| Power Dissipation | PD | -- | 1 | W |

1. Stresses beyond those listed under “absolute maximum ratings” may cause permanent damage to the device. These are stress ratings only, and functional operation of the device at these or any other conditions beyond those indicated under “recommended operating conditions” is not implied. Exposure to absolute-maximum-rated conditions for extended periods may affect device reliability.
2. The input and output negative-voltage ratings may be exceeded if the input and output clamp-current ratings are observed.
3. This current flows only when the output is in the high state and V_O > V_{CC}.

TABLE 3. DELTA LIMITS

| PARAMETER | VARIATION |
|--------------|------------------------------------|
| $I_{CC(OL)}$ | ±10% of specified value in Table 5 |
| $I_{CC(OH)}$ | ±10% of specified value in Table 5 |
| $I_{CC(OD)}$ | ±10% of specified value in Table 5 |

TABLE 4. 54LVTH162245 RECOMMENDED OPERATING CONDITIONS ¹

| PARAMETER | | SYMBOL | MIN | MAX | UNIT |
|------------------------------------|-----------------|--------------------------|-----|-----|-----------|
| Supply voltage | | V_{CC} | 2.7 | 3.6 | V |
| High-level input voltage | | V_{IH} | 2 | -- | V |
| Low-level input voltage | | V_{IL} | -- | 0.8 | V |
| Input voltage | | V_I | -- | 5.5 | V |
| High-level output current | A port | I_{OH} | -- | -12 | mA |
| | B port | | -- | -24 | |
| Low-level output current | A port | I_{OL} | -- | 12 | mA |
| | B port | | -- | 48 | |
| Input transition rise or fall rate | Outputs enabled | $\Delta t/\Delta v$ | -- | 10 | ns/V |
| Power-up ramp rate | | $\Delta t/\Delta V_{CC}$ | 200 | -- | $\mu s/V$ |
| Operating temperature | | T_A | -55 | 125 | °C |

1. All unused control inputs of the device must be held at high or low ensure proper device operation.

TABLE 5. 54LVTH162245 DC ELECTRICAL CHARACTERISTICS

($V_{CC} = 3.3V \pm 10\%$, $T_A = -55$ TO $+125$ °C, UNLESS OTHERWISE SPECIFIED)

| PARAMETER | SYMBOL | TEST CONDITIONS | SUBGROUPS | MIN | MAX | UNIT | |
|---------------------------|----------|---|-----------|---------|----------------|------|---|
| Input Clamp Voltage | V_{IK} | $V_{CC} = 2.7$ $I_I = -18$ mA | 1, 2, 3 | -- | -1.2 | V | |
| High-Level Output Voltage | V_{OH} | $V_{CC} = 2.7V$ to $3.6V$ $I_{OH} = -100$ μA | A Port | 1, 2, 3 | $V_{CC} - 0.2$ | -- | V |
| | | $V_{CC} = 3V$ $I_{OH} = -12$ mA | | | 2 | -- | |
| | | $V_{CC} = 2.7V$ to $3.6V$ $I_{OH} = -100$ μA | B Port | 1, 2, 3 | $V_{CC} - 0.2$ | -- | |
| | | $V_{CC} = 2.7V$ $I_{OH} = -8$ mA | | | 2.4 | -- | |
| | | $V_{CC} = 3V$, $I_{OH} = -24$ mA | | | 2 | -- | |

TABLE 5. 54LVTH162245 DC ELECTRICAL CHARACTERISTICS

 $(V_{CC} = 3.3V \pm 10\%, T_A = -55 \text{ TO } +125 \text{ }^\circ\text{C}, \text{ UNLESS OTHERWISE SPECIFIED})$

| PARAMETER | SYMBOL | TEST CONDITIONS | SUBGROUPS | MIN | MAX | UNIT | | |
|--------------------------|-------------------|---|-------------------------------|------------------|---------|-----------|---------|---------|
| Low-Level Output Voltage | V_{OL} | $V_{CC} = 2.7V \text{ to } 3.6V$ | $I_{OL} = 100 \mu A$ | A Port | 1, 2, 3 | -- | 0.2 | V |
| | | $V_{CC} = 3V$ | $I_{OL} = 12 \text{ mA}$ | | | -- | 0.8 | |
| | | $V_{CC} = 2.7V$ | $I_{OL} = 100 \mu A$ | B Port | 1, 2, 3 | -- | 0.2 | |
| | | | $I_{OL} = 24 \text{ mA}$ | | | -- | 0.5 | |
| | | $V_{CC} = 3V$ | $I_{OL} = 16 \text{ mA}$ | | | -- | 0.4 | |
| | | | $I_{OL} = 32 \text{ mA}$ | | | | 0.5 | |
| | | | $I_{OL} = 48 \text{ mA}$ | | | | 0.55 | |
| Input Current | I_I | $V_{CC} = 3.6V$ | $V_I = V_{CC} \text{ or GND}$ | Control inputs | 1, 2, 3 | -- | ± 1 | μA |
| | | $V_{CC} = 0 \text{ or } 3.6V$ | $V_I = 5.5V$ | | | -- | 10 | |
| | | $V_{CC} = 3.6V$ | $V_I = 5.5V$ | A or B Ports | 1, 2, 3 | -- | 20 | |
| | | | $V_I = V_{CC}$ | | | | 5 | |
| | | | $V_I = 0$ | | | -- | -10 | |
| Hold Current | $I_{I(HOLD)}$ | $V_{CC} = 3V$ | $V_I = 0.8V$ | A Inputs | 1, 2, 3 | 75 | -- | μA |
| | | | $V_I = 2V$ | | | -75 | -- | |
| Power Up Current | I_{OZPU}^2 | $V_{CC} = 0 \text{ to } 1.5V, V_O = 0.5V \text{ to } 3V, \overline{OE} = \text{don't care}$ | | 1, 2, 3 | -- | ± 100 | μA | |
| Power Down Current | I_{OZPD}^2 | $V_{CC} = 1.5V \text{ to } 0, V_O = 0.5V \text{ to } 3V, \overline{OE} = \text{don't care}$ | | 1, 2, 3 | -- | ± 100 | μA | |
| Supply Current | I_{CC} | $V_{CC} = 3.6V$ | | Outputs high | 1, 2, 3 | -- | 0.19 | mA |
| | | $I_O = 0$ | | Outputs low | 1, 2, 3 | -- | 5 | |
| | | $V_I = V_{CC} \text{ or GND}$ | | Outputs disabled | 1, 2, 3 | -- | 0.19 | |
| Delta Supply Current | ΔI_{CC}^1 | $V_{CC} = 3V \text{ to } 3.6V, \text{ One input at } V_{CC} - 0.6V, \text{ Other inputs at } V_{CC} \text{ or GND}$ | | 1, 2, 3 | -- | 0.3 | mA | |
| Input Capacitance | C_I^2 | $V_I = 3V \text{ or } 0$ | | 1, 2, 3 | -- | 8 | pF | |
| Input Output Capacitance | C_O^2 | $V_O = 3V \text{ or } 0$ | | 1, 2, 3 | -- | 15 | pF | |

1. This is the increase in supply current for each input that is at the specified TTL voltage level rather than V_{CC} or GND.
2. Guaranteed by design.

TABLE 6. 54LVTH162245 AC ELECTRICAL CHARACTERISTICS

 $(V_{CC} = 3.3V \pm 10\%, T_A = -55 \text{ TO } +125 \text{ }^\circ\text{C}, \text{ UNLESS OTHERWISE SPECIFIED})$

| PARAMETER | SYMBOL | SUBGROUPS | $V_{CC} = 3.3V \pm 0.3$ | | $V_{CC} = 2.7V$ | | UNIT |
|---|-------------|-----------|-------------------------|-----|-----------------|-----|------|
| | | | MIN | MAX | MIN | MAX | |
| Propagation Delay Time A to B | t_{PLH} | 9, 10, 11 | 1 | 3.5 | -- | 4 | ns |
| | t_{PHL} | 9, 10, 11 | 1 | 3.5 | -- | 3.9 | |
| Propagation Delay Time B to A | t_{PLH} | 9, 10, 11 | 1 | 4.3 | -- | 5.3 | ns |
| | t_{PHL} | 9, 10, 11 | 1 | 4.2 | -- | 4.5 | |
| Output Enable Time \overline{OE} to B | t_{PZH} | 9, 10, 11 | 1 | 4.8 | -- | 5.9 | ns |
| | t_{PZL} | 9, 10, 11 | 1 | 4.8 | -- | 5.5 | |
| Output Enable Time \overline{OE} to A | t_{PZH} | 9, 10, 11 | 1 | 5.5 | -- | 7.2 | ns |
| | t_{PZL} | 9, 10, 11 | 1 | 5.4 | -- | 6.4 | |
| Output Disable Time \overline{OE} to B | t_{PHZ} | 9, 10, 11 | 1 | 5.5 | -- | 5.8 | ns |
| | t_{PLZ} | 9, 10, 11 | 1 | 5.5 | -- | 5.8 | |
| Output Disable Time \overline{OE} to A | t_{PHZ} | 9, 10, 11 | 1 | 5.8 | -- | 6.5 | ns |
| | t_{PLZ} | 9, 10, 11 | 1 | 6.3 | -- | 6.3 | |
| Output Skew | $t_{sk(o)}$ | 9, 10, 11 | -- | -- | -- | -- | ns |

TABLE 7. FUNCTION TABLE

(EACH 8-BIT SECTION)

| INPUTS | | OPERATION |
|-----------------|-----|-----------------|
| \overline{OE} | DIR | |
| L | L | B data to A bus |
| I | H | A data to B bus |
| H | X | Isolation |

FIGURE 1. LOAD CIRCUIT

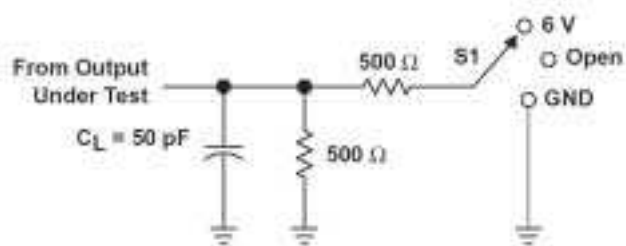

Figure Note:

1. C_L includes probe and jig capacitance.

PARAMETER MEASUREMENT INFORMATION

| TEST | S1 |
|-------------------|------|
| t_{PLH}/t_{PHL} | Open |
| t_{PLZ}/t_{PZL} | 6V |
| t_{PHZ}/t_{PZH} | GND |

FIGURE 2. PULSE DURATION

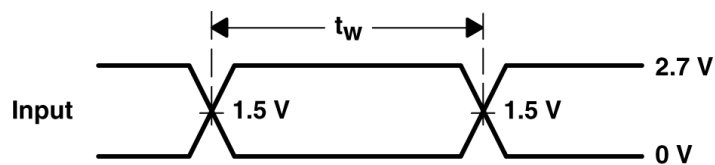

FIGURE 3. SETUP AND HOLD TIMES

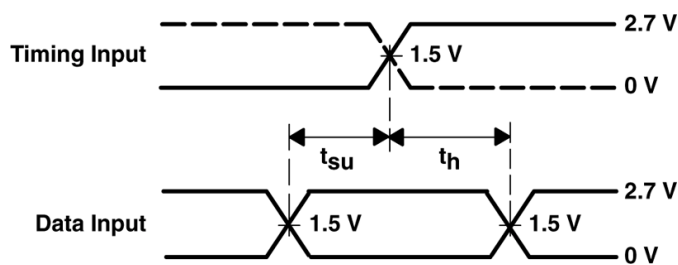

FIGURE 4. PROPAGATION DELAY TIMES INVERTING AND NONINVERTING OUTPUTS

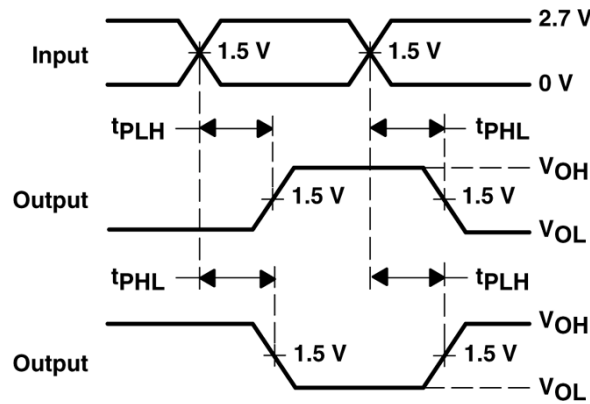

FIGURE 5. ENABLE AND DISABLE TIMES LOW- AND HIGH-LEVEL ENABLING

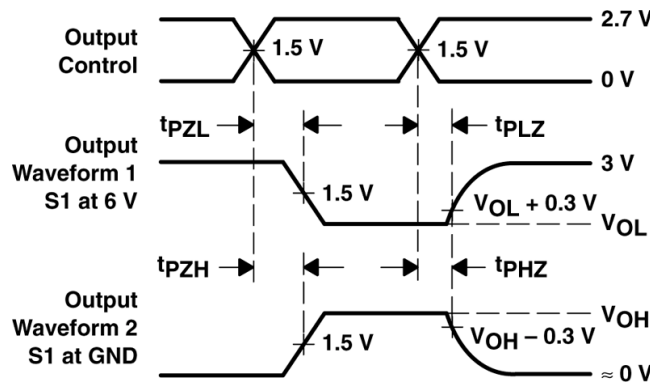
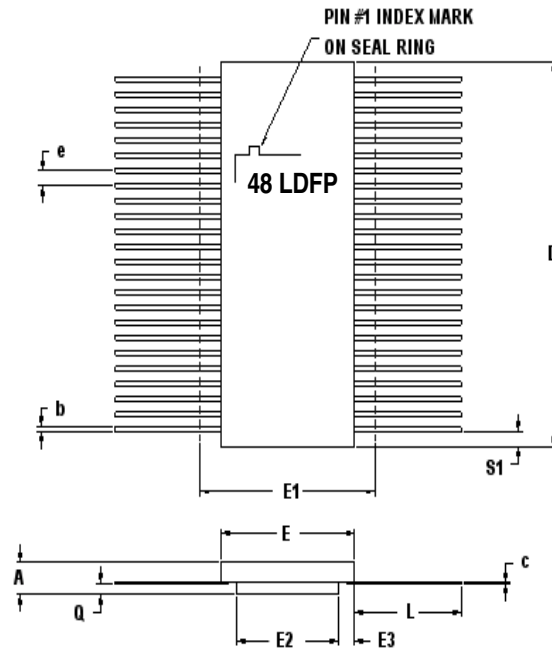

Figure Note:

- Waveform 1 is for an output with internal conditions such that the output is low except when disabled by the output control.
- Waveform 2 is for an output with internal conditions such that the output is high except when disabled by the output control.



48 PIN RAD-PAK® FLAT PACKAGE

| SYMBOL | DIMENSION | | |
|--------|-----------|-------|-------|
| | MIN | NOM | MAX |
| A | 0.144 | 0.160 | 0.165 |
| b | 0.008 | 0.010 | 0.014 |
| c | 0.004 | 0.006 | 0.007 |
| D | -- | 0.620 | 0.640 |
| E | 0.370 | 0.380 | 0.390 |
| E1 | -- | -- | 0.410 |
| E2 | 0.200 | 0.210 | 0.220 |
| E3 | 0.075 | 0.085 | -- |
| e | 0.025 BSC | | |
| L | 0.275 | 0.285 | 0.295 |
| Q | 0.013 | 0.019 | 0.025 |
| S1 | 0.005 | 0.018 | -- |
| N | 48 | | |

Note: All dimensions in inches

Important Notice:

These data sheets are created using the chip manufacturer's published specifications. Maxwell Technologies verifies functionality by testing key parameters either by 100% testing, sample testing or characterization.

The specifications presented within these data sheets represent the latest and most accurate information available to date. However, these specifications are subject to change without notice and Maxwell Technologies assumes no responsibility for the use of this information.

Maxwell Technologies' products are not authorized for use as critical components in life support devices or systems without express written approval from Maxwell Technologies.

Any claim against Maxwell Technologies must be made within 90 days from the date of shipment from Maxwell Technologies. Maxwell Technologies' liability shall be limited to replacement of defective parts.

Product Ordering Options

