

MEMS Gauge Pressure Sensor Featuring Small Size and Low Power Consumption

- Ultra-miniature 6.1 × 4.7 × 8.2 mm (L × W × H).
- Superior electrical characteristics to capacitive type pressure sensors.
- 0 to 37 kPa pressure range.
 - Offset voltage of -2.5 ± 4 mV
 - Span voltage of 31.0 ± 3.1 mV
- Low Power consumption of 0.2 mW
- Low Temperature Influence
 - Span of $\pm 1.0\%$ FS
 - Offset of $\pm 3.0\%$ FS

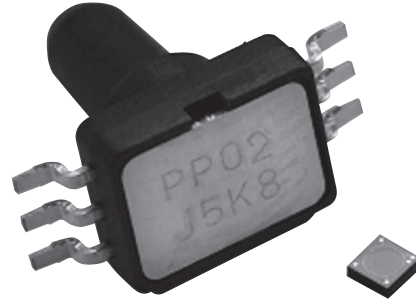

RoHS compliant



Refer to the *Safety Precautions* on page 6.

Terminal Arrangement

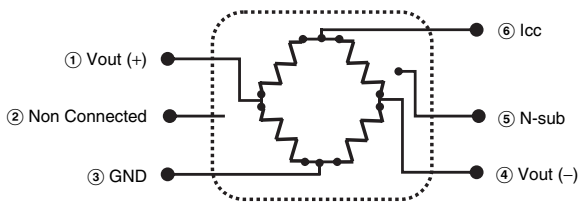

Connection Diagram

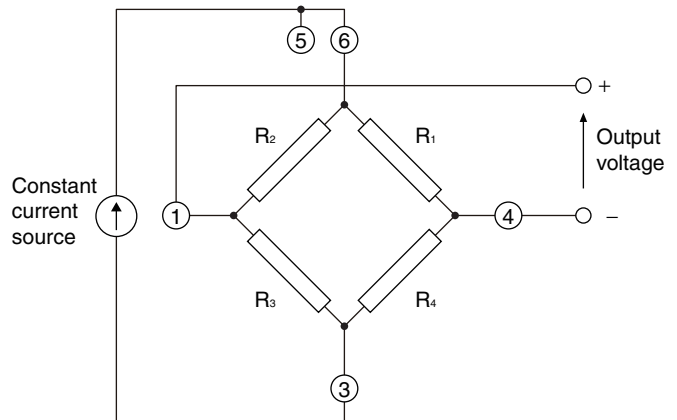

Note: If necessary, add a variable resistor below the GND pin (3).
The NC pin (2) must be secured to the circuit board.

Application Examples

- Medical equipment
- Home appliance
- Air movement control
- Level indicators
- Leak detection
- Pressure controller

Ordering Information

Standard Models with Surface mount package

Model	Classification	Structure	Packaging
2SMPP-02	Bottom Port Type	SOP	Plastic sleeve

Specifications

■ Ratings

Item	2SMPP-02
Type of pressure *1	Gauge pressure
Sensing method*2	Piezoresistance
Pressure medium	Air
Driving method	Constant current drive
Drive current	100 μ A DC
Pressure range	0 to 37 kPa
Maximum allowable pressure	53 kPa
Maximum drive current	130 μ A DC
Ambient operating temperature range	0 to 50°C (with no condensation or icing)
Ambient operating humidity range	15% to 95% (with no condensation or icing)
Ambient storage temperature range	-30 to 85°C (with no condensation or icing)
Ambient storage humidity range	10% to 95% (with no condensation or icing)
Weight	0.17 g

Note: The above specifications are the results of measurements taken at an ambient temperature of 23°C.

*1 Do not use the Sensor under negative pressure.

*2 Do not use any corrosive gases. Use only air.

Characteristics

■ Electrical Characteristics

Item	2SMPP-02
Gauge resistance value	20 \pm 2 k Ω
Offset voltage	-2.5 \pm 4.0 mV
Span voltage	31.0 \pm 3.1 mV (with an applied pressure of 37 kPa)
Non-linearity	0.8% FS max. (0 to 37 kPa)
Hysteresis	0.5% FS (0 to 37 kPa)
Sensitivity variation with temperature	0.5 \pm 1.0% FS (0°C)
	0.3 \pm 1.0% FS (50°C)
Offset voltage variation with temperature	0 \pm 3.0% FS (0 to 25°C)
	0 \pm 3.0% FS (25 to 50°C)

Measurement conditions: Ambient temperature = 23°C, constant current and drive current = 100 μ A

Example of Application Circuit for MEMS Pressure Sensor

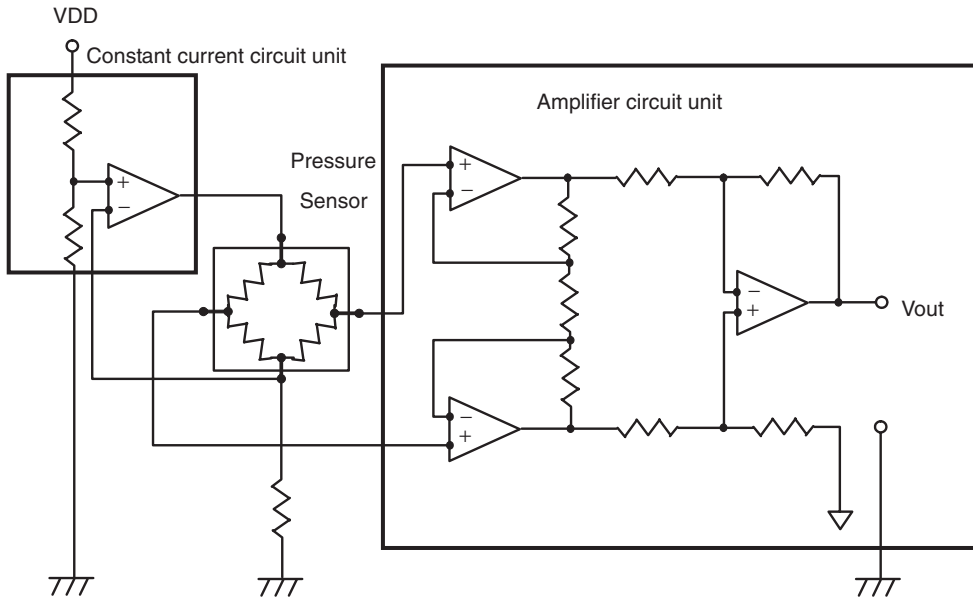

1. The pressure sensor is designed to convert a voltage by means of constant current drive.
2. Please amplify the output voltage of the pressure sensor by using the amplifying circuit if necessary.

Engineering Data (for Reference)

■ Output Characteristics

Rated Pressure vs. Output Voltage

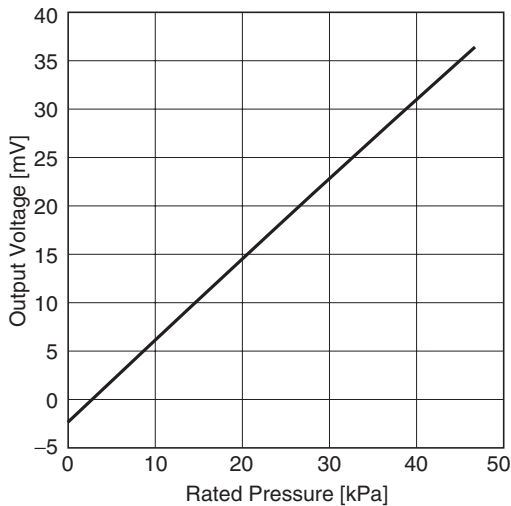

- Note:**
1. Ambient temperature condition: 25°C
 2. Drive current: 100 μ A
 3. These output voltage characteristics are measured with tester without a mounting board.
 4. The output voltage characteristics may be influenced by the mounting board. Be sure to check operation including durability in actual equipment before use.

Temperature Influence of Span Voltage

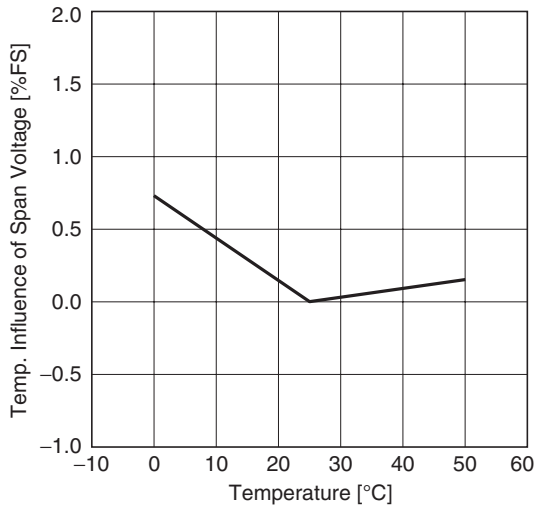

Temperature Influence of Offset Voltage

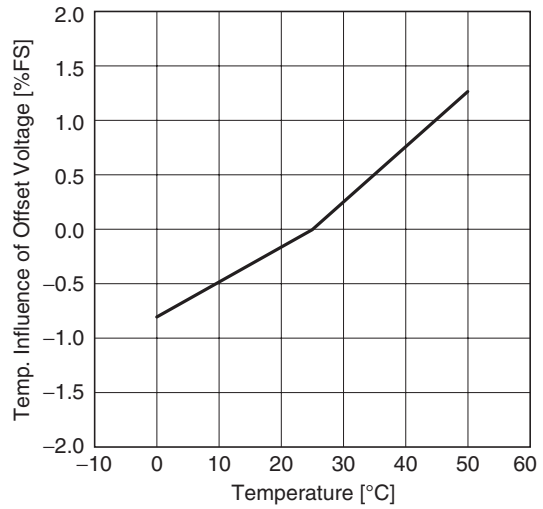

- Note:**
1. Measured points are 0°C and 25°C, 50°C
 2. Drive current: 100 μA
 3. These output voltage characteristics are measured with tester without a mounting board.
 4. The output voltage characteristics may be influenced by the mounting board. Be sure to check operation including durability in actual equipment before use.

Pressure Cycle Range (0 to 40 kPa)

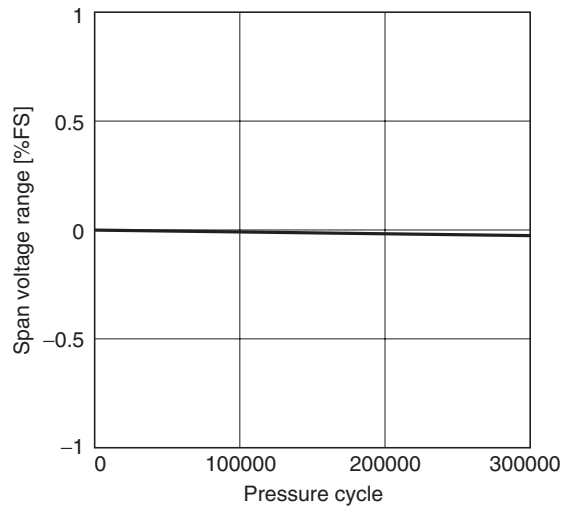
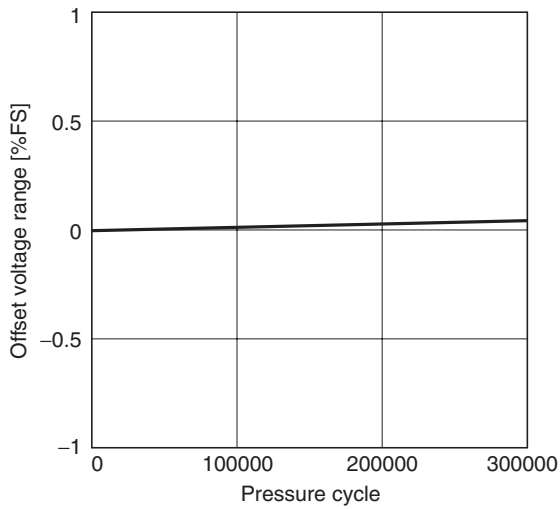

- Note:**
1. Tested temperature condition: 25°C
 2. Number of pressure cycle time: 3×10^5
 3. Rated cycle pressure: 0 to 40 kPa
 4. These output voltage characteristics are measured with tester without a mounting board.

Dimensions

Note: All units are in millimeters unless otherwise indicated.

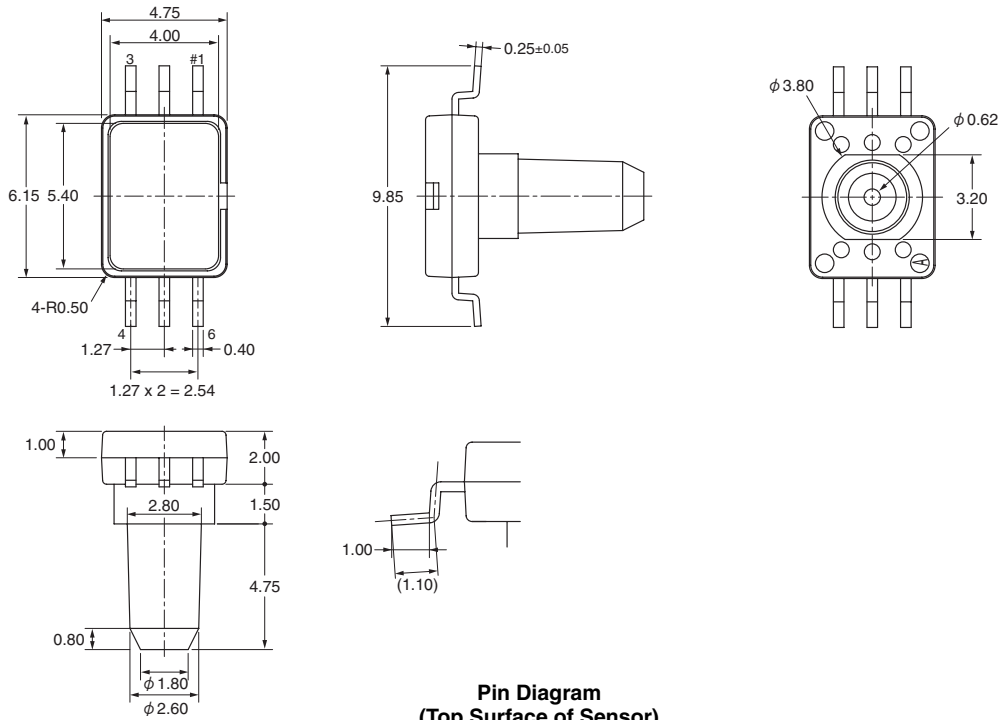

**Pin Diagram
(Top Surface of Sensor)**

Atmospheric pressure hole

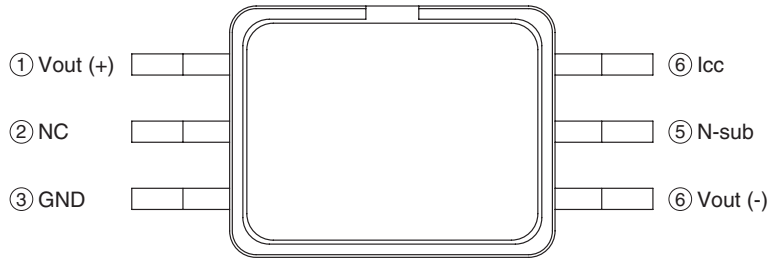

Markings

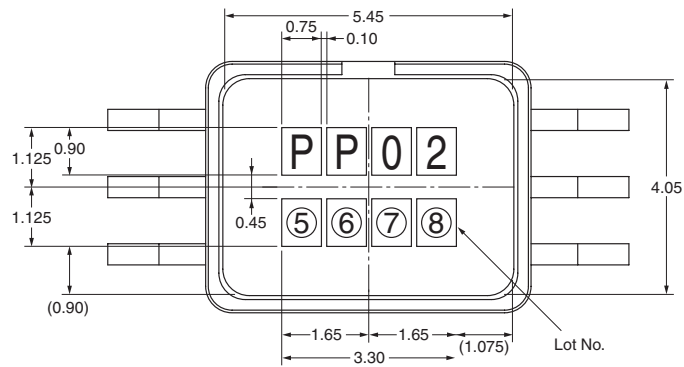

Note: Unless otherwise specified, the tolerance for all of the above drawings is ±0.3 mm.

Safety Precautions

Precautions for Correct Use

Handling the Sensor

- (1) Air is the only pressure medium that may be used directly with the Sensor. Do not use corrosive gases (organic solvent gases, sulfurous gases, hydrogen sulfide gas, etc.) or pressure mediums containing water particles. These pressure mediums may cause malfunctions.
- (2) The Sensor is not drip-proof. Do not use the Sensor in any environment where it may be subjected to water or other liquids.
- (3) Do not use the Sensor in any environment where condensation may occur. If moisture freezes on the Sensor chip, variations may occur in the Sensor output or the Sensor may malfunction.
- (4) Do not insert wires, pins, or any other foreign objects into the connecting tube. Doing so could destroy the pressure sensor chip inside the Sensor, or the foreign object may become stuck inside the connecting tube and affect the Sensor output.
- (5) Always stay within the rated pressure range. Using a pressure outside of this range may damage the Sensor.
- (6) Do not use the Sensor in any environment subject to vibration from ultrasonic or high-frequency waves.
- (7) The Sensor output may be affected if the pressure sensor chip is exposed to light. Do not expose the Sensor chip to light.
- (8) Static electricity may destroy the Sensor. Any charged materials or surfaces, such as workbenches, floors, or technicians, must be properly grounded to prevent static electricity.
- (9) Applying excessive force to the pins may deform them and damage the soldering. Do not drop the Sensor and always handle it with care. Do not use the Sensor in any environment that is subject to excessive steam or dust.
- (10) Refer to the connection diagrams when connecting the pins on the Sensor.
- (11) Do not connect to the pins on the Sensor in the wrong direction. Doing so may cause variations in Sensor output or malfunctions.
- (12) External noise may effect the Sensor output. Take any necessary measures to eliminate external noise.

Transportation and Storage

- (1) Do not store the Sensor in any environment that contains corrosive gases (organic solvent gases, sulfurous gases, hydrogen sulfide gas, etc.).
- (2) The Sensor is not drip-proof. Do not store the Sensor in any environment where it may be subjected to water or other liquids.
- (3) The cardboard packaging will deteriorate over time depending on the humidity, number of boxes stacked on top, and other factors. Follow the first in, first out rule for storage. Do not drop or throw the Sensor. Handle it with care.
- (4) If the inner packaging is dropped, the stopper may be dislodged from the tube causing the Sensor to fall out and become damaged.
- (5) The surface of the tube containing the Sensor is coated in a film to prevent static electricity. Observe the following items regarding this protective coating:
 1. Avoid exposure to water, which may wash away the protective coating.
 2. The protective anti-static electricity coating may be sticky to the touch in high-temperature, high-humidity environments.

3. The protective anti-static electricity coating degrades over time. Do not store the Sensor for more than 6 months. Also, do not reuse the packaging.
- (4) Store the Sensor in an environment with suitable temperature and humidity levels.
 - Temperature: 5 to 30°C, Humidity: 40% to 60%
- (5) Leads are silver-plated and may change color over time depending on the storage conditions. Discoloration after the Sensor is delivered is not covered under warranty. Be sure to store the Sensor under the proper conditions.
- (6) Do not store the Sensor in any environment with excessive steam or dust.

Mounting Method

- Mount the Sensor on the land pattern of a printed circuit board.
- Solder pin 2 securely to the printed circuit board in order to maintain the mechanical strength of the mounted Sensor.

Soldering Method

- Due to its small size, the heat capacity of the Sensor is limited. Therefore, measures must be taken to minimize the effects of heating from external sources.
- Solder bath submersion: 260°C max. for 10 seconds max.
- Soldering iron: 260°C max. for 10 seconds max.
- Apply heat to the Sensor pins only, and not to the Sensor package.
- Do not use any flux that may release corrosive gases. Do not allow any flux to enter the inside of the case.

Cleaning

- Do not allow any cleaning liquid to enter the inside of the case.
- Do not use ultrasonic cleaning. Doing so may break connections.
- Do not use any cleaning liquids that contain silicone. Such cleaning liquids may remain on the surface of the Sensor.

Coating

- Do not apply any coating to the Sensor.

ALL DIMENSIONS SHOWN ARE IN MILLIMETERS.

To convert millimeters into inches, multiply by 0.03937. To convert grams into ounces, multiply by 0.03527.

Cat. No. A195-E1-02 **In the interest of product improvement, specifications are subject to change without notice.**

OMRON Corporation

Micro Devices Division

686-1 Ichimiyake, Yasu,
Shiga, 520-2362 JAPAN

Tel: (81)77-588-9200/Fax: (81)77-588-9909

0712