

D7E

Sealed Vibration Sensors and Tilt Sensor

Quickly Detect Vibration or Tilting to Help Prevent Secondary Disasters. Affordable Vibration/Tilt Sensors with Sealed Structure.

- Sealing performance to IP67 degree of protection (switch section).
- Applicable to stoves, oil heaters, and other applications that require resistance to harsh environments.
- A Tilt Sensor is also provide in the lineup.

RoHS Compliant

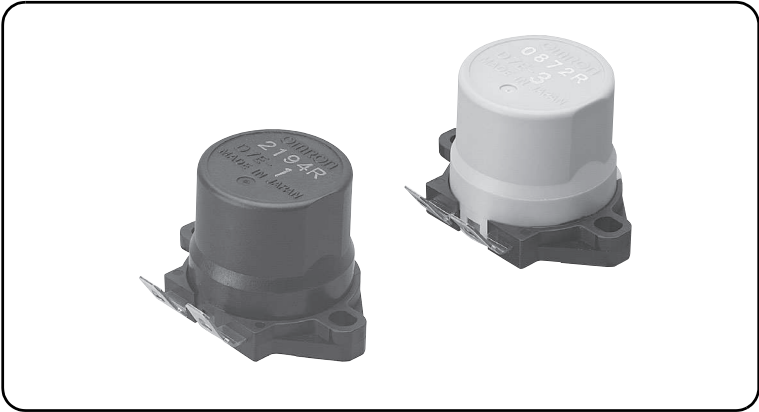

Ordering Information

Type	Model
Vibration Sensors	D7E-1
	D7E-2
	D7E-5
Tilt Sensor	D7E-3

Performance

Item	Model Type	D7E-1	D7E-2	D7E-5	D7E-3
		Vibration Sensors			Tilt Sensor
Set acceleration		130 to 200 gals*	100 to 170 gals*	120 to 195 gals*	
Operating characteristic					

* These are the accelerations for operation at periods of 0.3 s, 0.5 s, and 0.7 s measured with the horizontal vibration method. Mounting standard: $\pm 30'$ ($\pm 0.5^\circ$).