



SEMITRANS™ M1

Power MOSFET Modules

SKM 111AR

Features

- N Channel, enhancement mode
- Avalanche characteristic
- Short connections and built-in gate resistors to suppress internal oscillations even in critical applications
- Isolated copper baseplate
- All electrical connections on top for easy busbaring
- Large clearances (10 mm) and creepage distances (20 mm)
- UL recognized, file no. E 63 532

Typical Applications*

- Switched mode power supplies
- DC servo and robot drives
- DC choppers
- UPS equipment
- Not suitable for linear amplification



MA

Absolute Maximum Ratings		$T_c = 25\text{ °C}$, unless otherwise specified	
Symbol	Conditions	Values	Units
V_{DS}		100	V
I_D	$T_s = 25\text{ (80) °C}$	200 (150)	A
I_{DM}	1 ms	600	A
V_{GS}		± 20	V
T_{vj} (T_{stg})		- 40 ... + 150 (125)	°C
V_{isol}	AC, 1 min.	2500	V
Inverse diode			
$I_F = -I_S$		200	A
$I_{FM} = -I_{SM}$		600	A

Characteristics		$T_c = 25\text{ °C}$, unless otherwise specified			
Symbol	Conditions	min.	typ.	max.	Units
$V_{(BR)DSS}$	$V_{GS} = 0\text{ V}$, $I_D = 0,25\text{ mA}$	100			V
$V_{GS(th)}$	$V_{GS} = V_{DS}$, $I_D = 1\text{ mA}$	2,1	3	4	V
I_{DSS}	$V_{GS} = 0\text{ V}$, $V_{DS} = 100\text{ V}$, $T_j = 25\text{ (125) °C}$		50 (300)	250 (1000)	μA
I_{GSS}	$V_{GS} = 20\text{ V}$, $V_{DS} = 0\text{ V}$		10	100	nA
$R_{DS(on)}$	$V_{GS} = 10\text{ V}$, $I_D = 130\text{ A}$		7	8,5	m Ω
g_{fs}	$V_{DS} = 25\text{ V}$, $I_D = 130\text{ A}$	60	75		S
C_{CHC}	$V_{GS} = 0$, $V_{DS} = 25\text{ V}$, $f = 1\text{ MHz}$			160	pF
C_{iss}			10	13	nF
C_{oss}			5	7,5	nF
C_{rss}			1,8	2,7	nF
L_{DS}				20	nH
$t_{d(on)}$	$V_{DD} = 50\text{ V}$, $I_D = 130\text{ A}$,		60		ns
t_r	$V_{GS} = 10\text{ V}$, $R_G = 3,3\ \Omega$		220		ns
$t_{d(off)}$			270		ns
t_f			200		ns
Inverse diode					
V_{SD}	$I_F = 400\text{ A}$; $V_{GS} = 0\text{ V}$		1,25	1,6	V
t_{rr}	$T_j = 25\text{ (150) °C}$		400		ns
Q_{rr}	$T_j = 25\text{ °C}$		3,5		μC
I_{rr}	$T_j = 150\text{ °C}$				A
Thermal characteristics					
$R_{th(j-c)}$	per MOSFET			0,18	K/W
$R_{th(c-s)}$	M_s , surface $10\ \mu\text{m}$, per module			0,05	K/W
Mechanical data					
M_s	to heatsink (M6)	4		5	Nm
M_t	for terminals (M5)	2,5		3,5	Nm
w				130	g

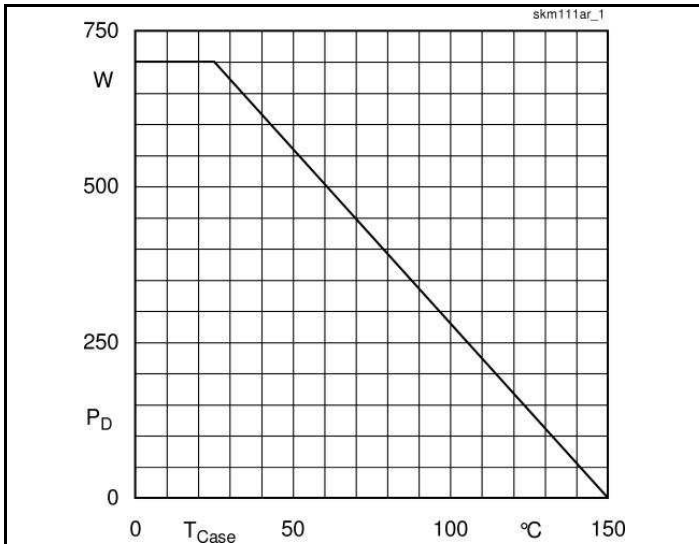

Fig. 1 Rated power dissipation vs. temperature

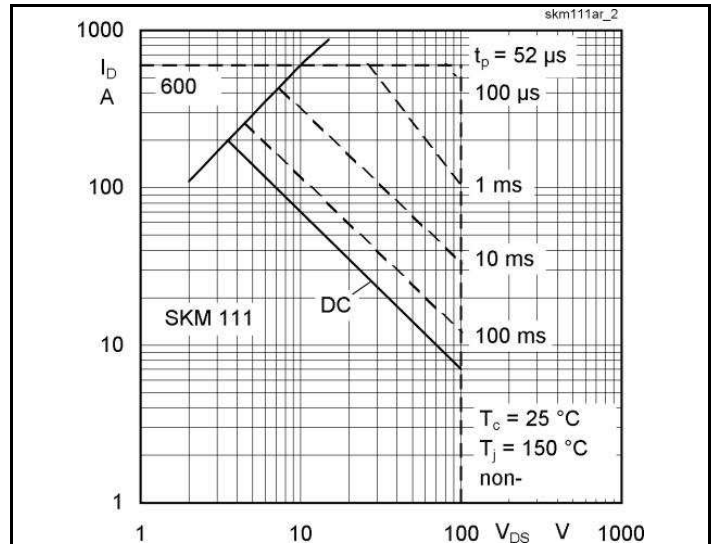

Fig. 2 Maximum safe operating area

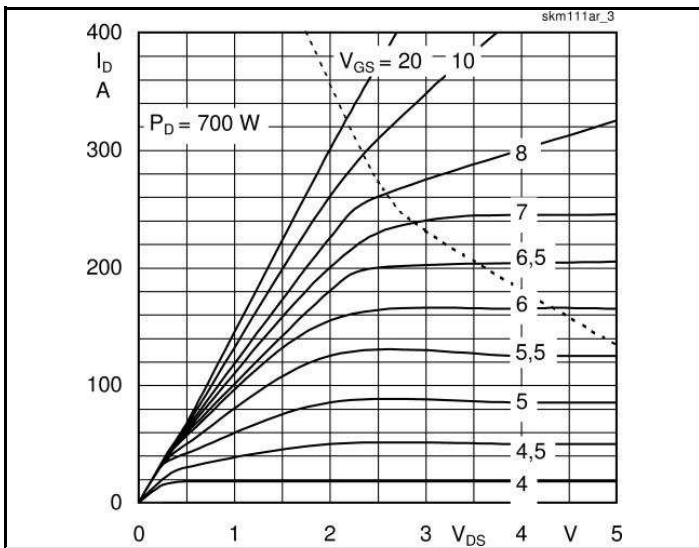

Fig. 3 Output characteristic

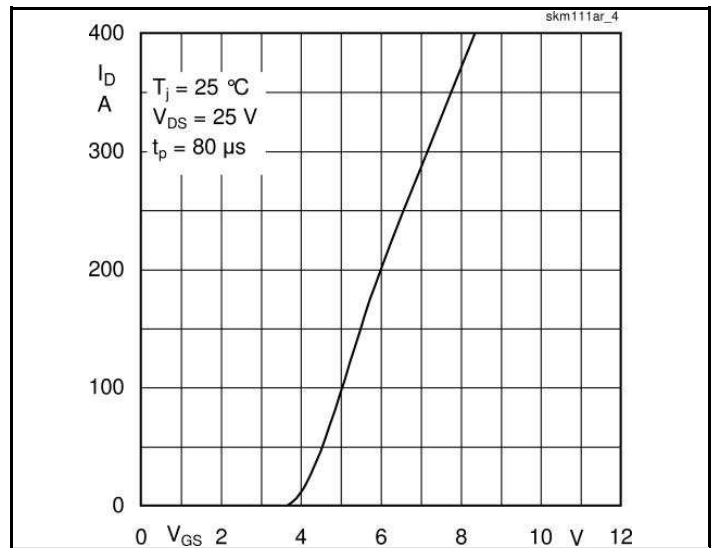

Fig. 4 Transfer characteristic

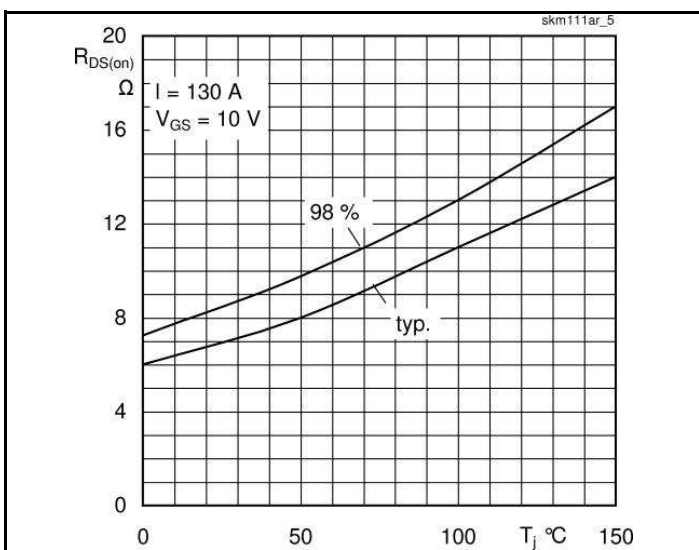

Fig. 5 On-resistance vs. temperature

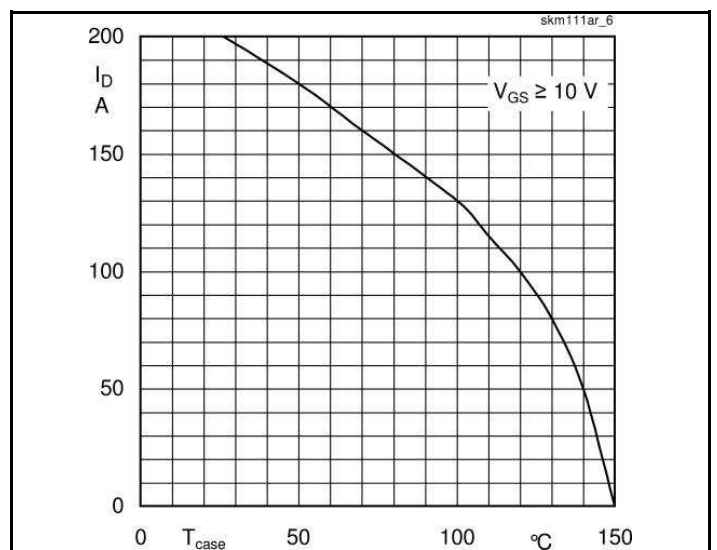

Fig. 6 Rated current vs. temperature

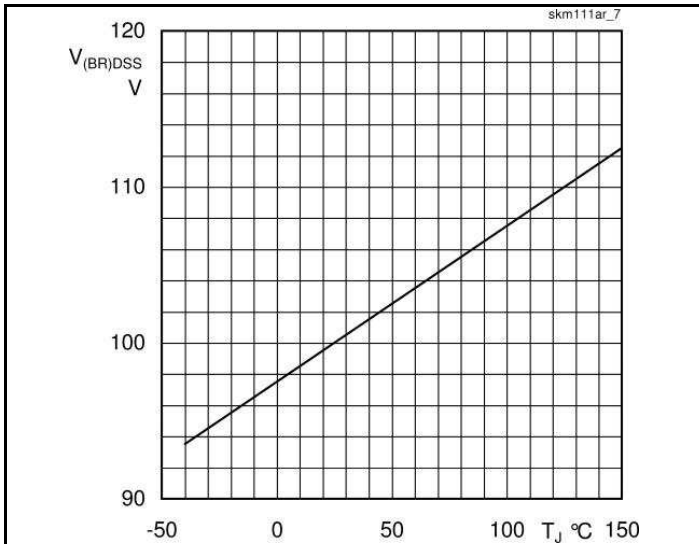

Fig. 7 Brakdown voltage vs. temperature

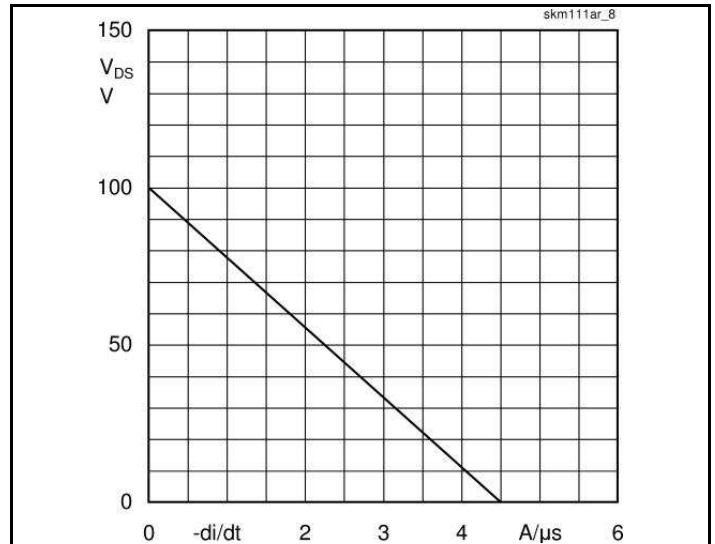

Fig. 8 Drain-source voltage derating

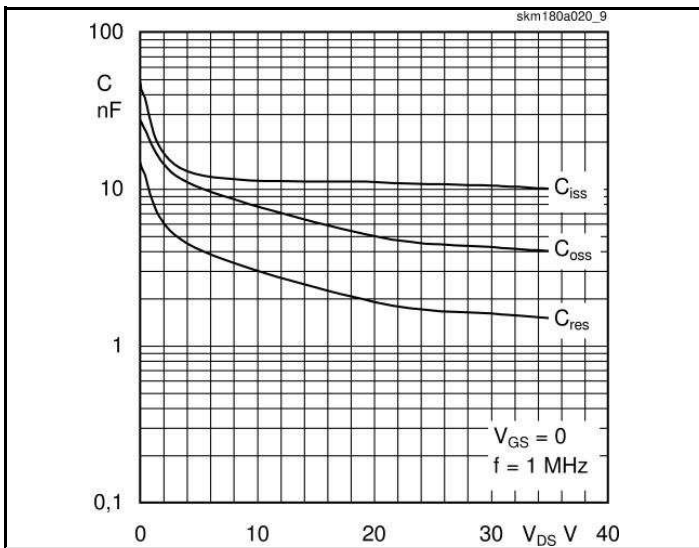

Fig. 9 Capacitances vs. drain-source voltage

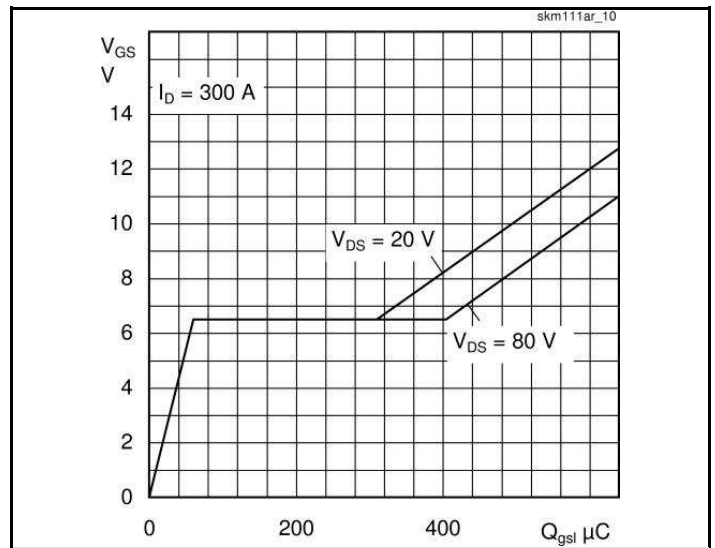

Fig. 10 Gate charge characteristic

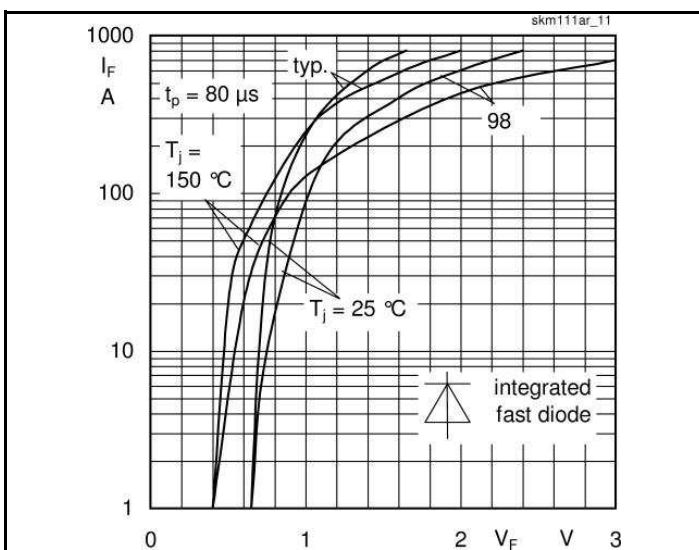

Fig. 11 Diode forward characteristic

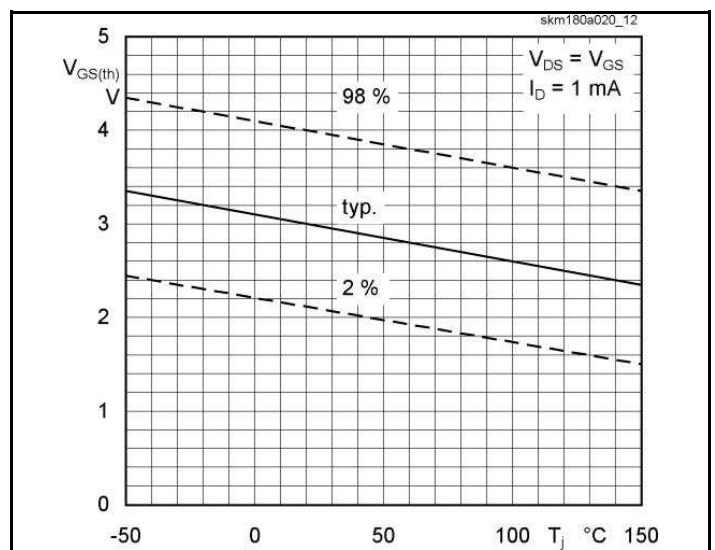
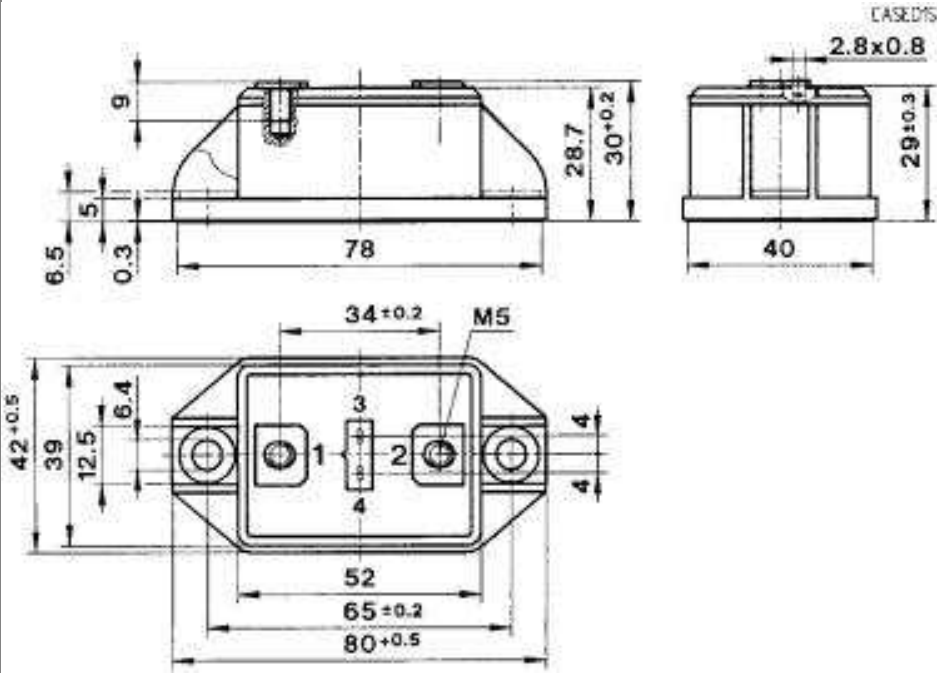

Fig. 14 Gate-source threshold voltage

SKM 111AR

UL Recognized
File no. E 63 532

Dimensions in mm



Case D15

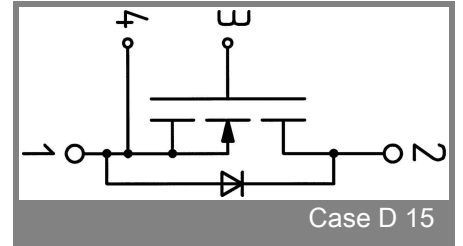

Case D 15

This is an electrostatic discharge sensitive device (ESDS), international standard IEC 60747-1, Chapter IX.

* The specifications of our components may not be considered as an assurance of component characteristics. Components have to be tested for the respective application. Adjustments may be necessary. The use of SEMIKRON products in life support appliances and systems is subject to prior specification and written approval by SEMIKRON. We therefore strongly recommend prior consultation of our personal.