

IGDD6-2-426-D1616-E1F12-DH-FA



IGBT Module Stack

Three-phase inverter + input rectifier

SEMIKUBE - Size 1

IGDD6-2-426-D1616-E1F12-DH-FA

Preliminary Data

Features

- Highly compact
- Integrated current, voltage and temperature sensors
- Easy maintenance
- Easy mounting and dismounting
- Very high Life-Time Expectancy
- Very low inductive DC bus

Typical Applications

- Industrial
- AC motor control
- UPS
- Solar inverter
- Oil and gas pumps

No. 08800991

Footnotes

Electrical parameters to be derated for $T_{amb} > 40^{\circ}\text{C}$

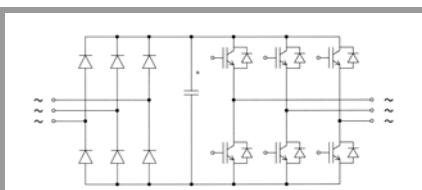

B6U + B6C1

Characteristics						
Symbol	Conditions	min.	typ.	max.	Unit	
Electrical Data						
I_{rms}	$T_{amb}=40^{\circ}\text{C}$, 3kHz, 650V _{dc} , 400V _{ac} , cos=0,85	no overload		330	A	
		110% overload, 60s every 10min		320	360	A
		150% overload, 60s every 10min		260	390	A
V_{CES}				1200	V	
f_{sw}	max. switching frequency			10.4	kHz	
V_{DC}	DC voltage applied to the capacitor bank			750	V	
V_{AC}	network voltage (line side), -20% / +15%			460	V	
V_{isol}	50Hz / 1min			2500	V	
P_{tot}	$T_{amb}=40^{\circ}\text{C}$		3120		W	
T_j	T_{vj} for continuous operation	-40		125	$^{\circ}\text{C}$	
Capacitor Data						
C_{DC}	SKG4M7-40A1		14.1		mF	
C			Electrolyt			
LTE	expected lifetime calculated, forced air cooling	60			kHrs	
		30			kHrs	
Controller Interface Data						
V_S	supply voltage primary side	21.6	24	26.4	V	
I_{SO}	supply current primary side (+ external current sensors)	360		1500	mA	
V_{IT+}	Input threshold voltage (HIGH)			$0,7 \cdot V_S$	V	
V_{IT-}	Input threshold voltage (LOW)	$0,3 \cdot V_S$			V	
R_{IN}	Input resistance		17		k Ω	
I_{TRIPSC}	Over current trip level		900		A _{PEAK}	
T_{tp}	Over temperature protection level		100		$^{\circ}\text{C}$	
Mechanical Data						
dv/dt_{AIR}	required airflow per fan	620			m ³ /h	
w	approx. total weight		36		kg	
Size	Width x Depth x Height (with fan)	541	755	372	mm	
T_{stg}	w/o need of reforming the caps	-20		40	$^{\circ}\text{C}$	
T_{amb}		-20		55	$^{\circ}\text{C}$	
T_{hs}					$^{\circ}\text{C}$	
Alltitude	installation height w/o derating			1000	m	
Protection			IP00			
Pollution	EN 50178		2			
Fan Data						
Fan	included in the stack (NO)					
Type	(SKF 16 O-230-01)					
V_{Fan}	Fan voltage		230		V	
f_{FAN}	Fan frequency		50		Hz	
I_{FAN}	Fan current		1.3		A	
P_{FAN}	Fan power		300		W	

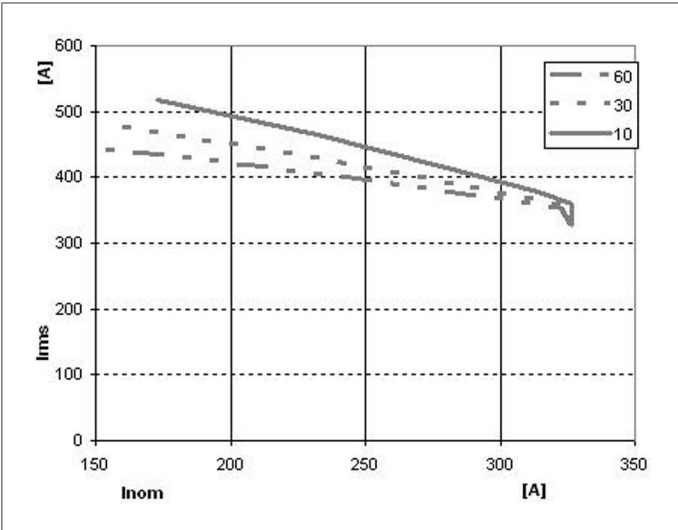

Fig. 1 Maximum overload current, $T_{amb} = 40\text{ °C}$

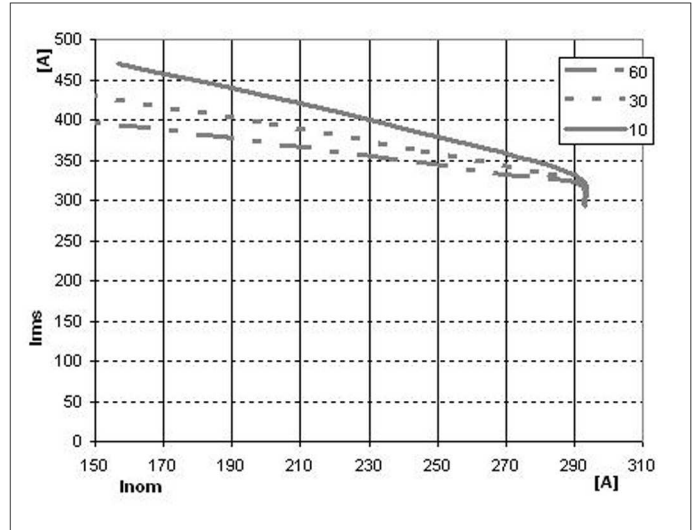

Fig. 2 Maximum overload current, $T_{amb} = 50\text{ °C}$

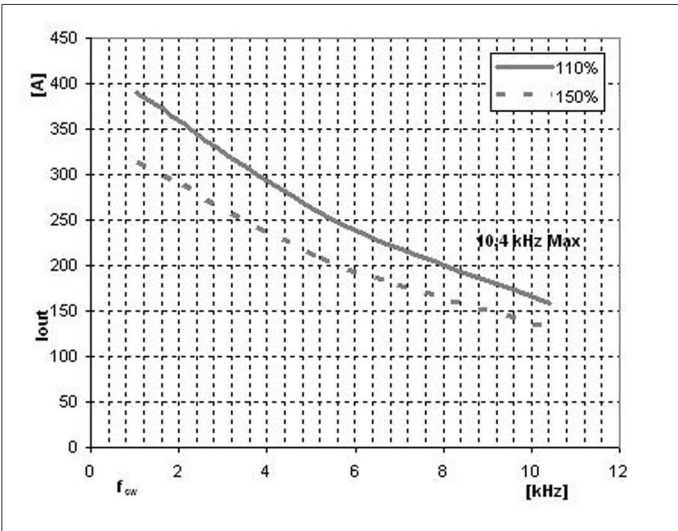

Fig. 3 Max permanent inverter curr. vs. f_{sw} , $T_{amb}=40\text{ °C}$

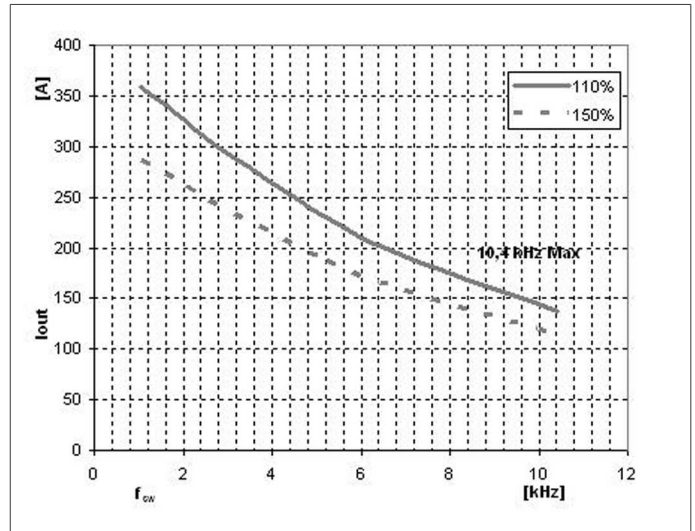

Fig. 4 Max. permanent inverter curr. vs. f_{sw} , $T_{amb}=50\text{ °C}$

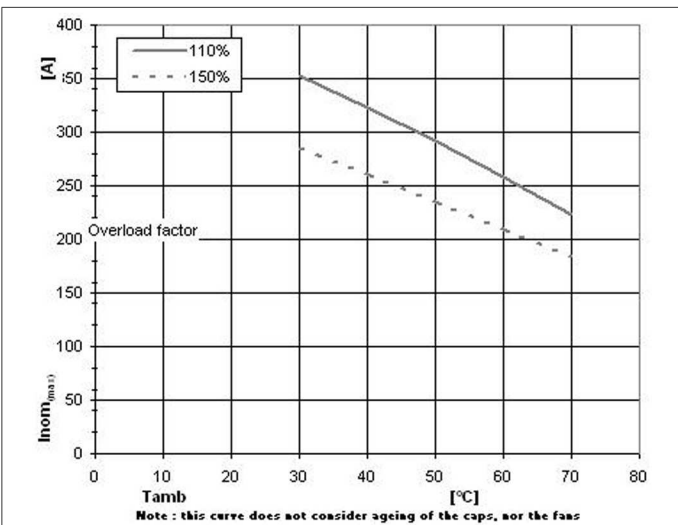

Fig. 5 Max. nominal curr. vs. ambient temperature

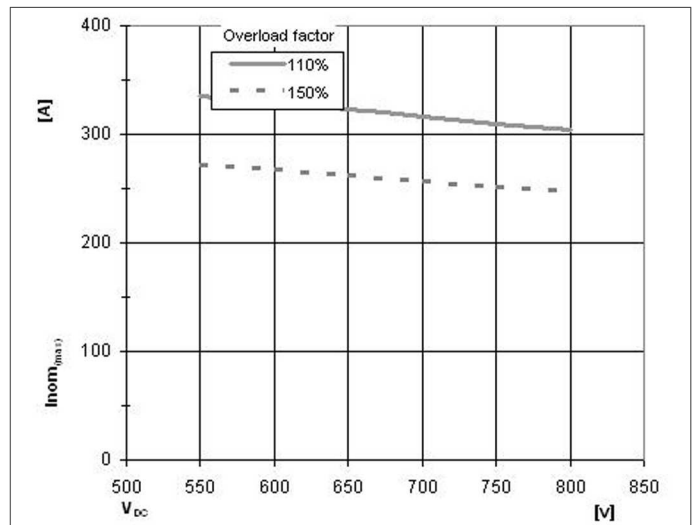
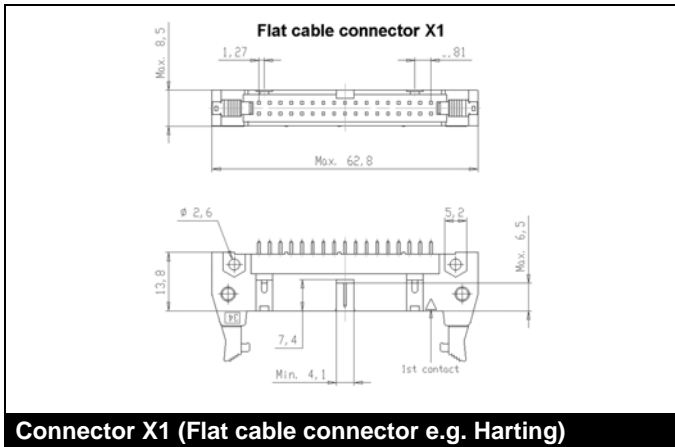

Fig. 6 Maximum nominal current vs. DC Link voltage

PIN Array X1

PIN	Signal	Function	Specifications
X1:01	IF_PWR_VP	Power Supply	Supply voltage +24V _{DC} (±10%) IN
X1:02	IF_PWR_GND	GND_for_IF_PWR_VP	
X1:03	IF_PWR_VP	Power Supply	Supply voltage +24V _{DC} (±10%) IN
X1:04	IF_PWR_GND	GND_for_IF_PWR_VP	
X1:05	IF_PWR_VP	Power Supply	Supply voltage +24V _{DC} (±10%) IN
X1:06	IF_PWR_GND	GND_for_IF_PWR_VP	
X1:07	IF_CMN_rsvd	Reserved	
X1:08	IF_CMN_GND	GND for IF_CMN_nHALT, IF_CMNrsrvd	
X1:09	IF_CMN_nHALT	Status signal	Digital IF_PWR_VP logic LOW (dominant) = not ready to operate HIGH (recessive) = ready to operate
X1:10	IF_CMN_rsvd	Reserved [dominant recessive]	
X1:11	IF_CMN_ANLG0	Temperature analog out	Max. output current: 5mA Turns ratio: 100mV/°C Max. voltage range: +15V Nominal voltage range: 0...10V
X1:12	IF_CMN_AGND0	GND for IF_CMN_ANLG0	
X1:13	IF_CMN_ANLG1	U _{DC} analog out	Max. output current: 5mA Turns ratio: 10mV/V Max. voltage range: +15V Nominal voltage range: 0...10V
X1:14	IF_CMN_AGND1	GND for IF_CMN_ANLG1	
X1:15	IF_HB1_TOP	Switching signal input (HB1 TOP switch)	Digital IF_PWR_VP logic LOW = TOP switch off HIGH = TOP switch on
X1:16	IF_HB1_BOT	Switching signal input (HB1 BOT switch)	Digital IF_PWR_VP logic LOW = BOT switch off HIGH = BOT switch on
X1:17	IF_HB1_rsvd	Reserved	
X1:18	IF_HB1_GND	GND for IF_HB1_TOP, IF_HB1_BOT, IF_HB1_rsvd	
X1:19	IF_HB1_ANLG	I analog out HB1	Max. output current: 5mA Turns ratio: 12 / 24mV/A Max. voltage range: ±15V Nominal voltage range: 0...10V
X1:20	IF_HB1_AGND	GND for IF_HB1_ANLG	
X1:21	IF_HB2_TOP	Switching signal input (HB2 TOP switch) [push pull]	Digital IF_PWR_VP logic LOW = TOP switch off HIGH = TOP switch on
X1:22	IF_HB2_BOT	Switching signal input (HB2 BOT switch) [push pull]	Digital IF_PWR_VP logic LOW = BOT switch off HIGH = BOT switch on
X1:23	IF_HB2_rsvd	Reserved [dominant recessive]	

PIN	Signal	Function	Specifications
X1:24	IF_HB2_GND	GND for IF_HB2_TOP, IF_HB2_BOT, IF_HB2_rsvd	
X1:25	IF_HB2_ANLG	I analog out HB2	Max. output current: 5mA Turns ratio: 12 / 24mV/A Max. voltage range: ±15V Nominal voltage range: 0 ... 10V
X1:26	IF_HB2_AGND	GND for IF_HB2_ANLG	
X1:27	IF_HB3_TOP	Switching signal input (HB3 TOP switch) [push pull]	Digital IF_PWR_VP logic LOW = TOP switch off HIGH = TOP switch on
X1:28	IF_HB3_BOT	Switching signal input (HB3 BOT switch) [push pull]	Digital IF_PWR_VP logic LOW = BOT switch off HIGH = BOT switch on
X1:29	IF_HB3_rsvd	Reserved [dominant recessive]	
X1:30	IF_HB3_GND	GND for IF_HB3_TOP, IF_HB3_BOT, IF_HB3_rsvd	
X1:31	IF_HB3_ANLG	I analog out HB3	Max. output current: 5mA Turns ratio: 12 / 24mV/A Max. voltage range: ±15V Nominal voltage range: 0 ... 10V
X1:32	IF_HB3_AGND	GND for IF_HB3_ANLG	
X1:33	IF_rsvd	Reserved	
X1:34	IF_GND_rsvd	Reserved	



Product information of suitable female connectors and distributor contact information is available at e.g. <http://www.harting.com> (part number 09 18 520 7 813 – female connector with strain relief clamp).

IGDD6-2-426-D1616-E1F12-DH-FA

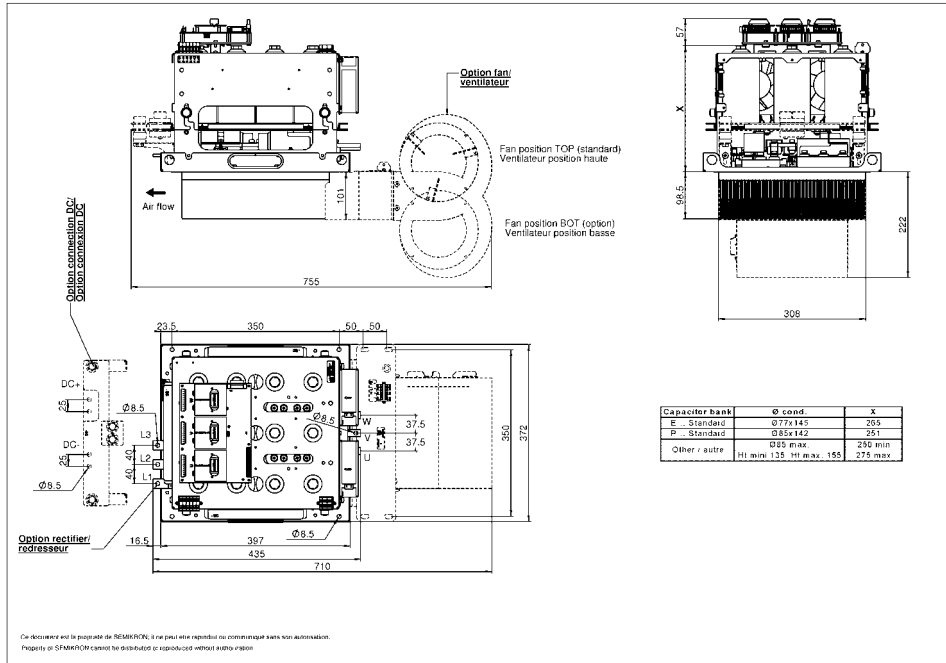

SEMIKUBE GDD6-2A, Px308/308

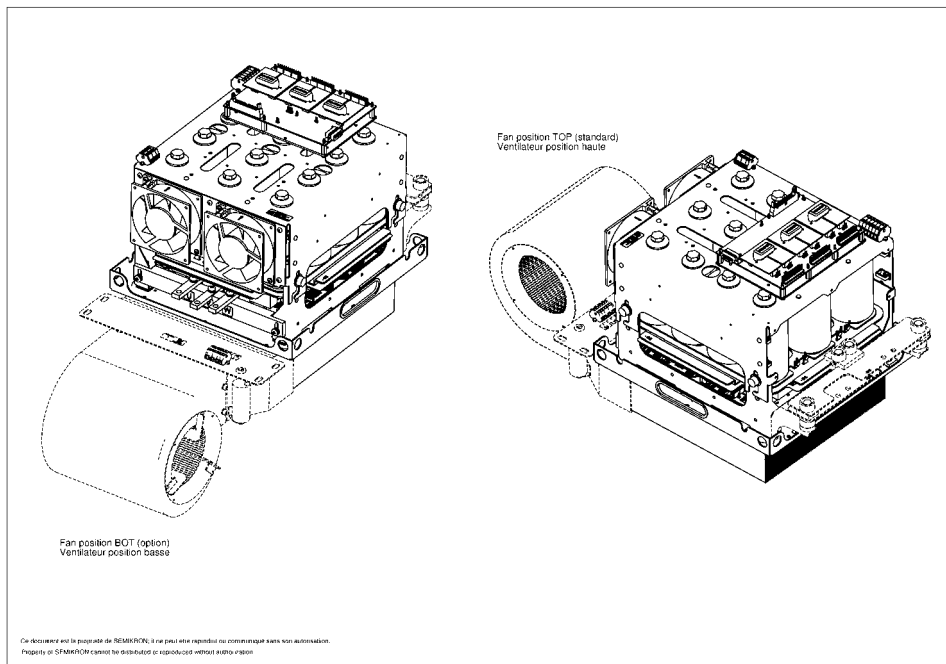

3D view of the SEMIKUBE Size '1'

This technical information specifies semiconductor devices but promises no characteristics. No warranty or guarantee expressed or implied is made regarding delivery, performance or suitability.