



**RDL**<sup>®</sup>  
Radio Design Labs

SPECIALISTS IN PRACTICAL PRECISION ENGINEERING™

## FLAT-PAK™ SERIES Model FP-TPX3A Format-A Twisted Pair Remote Controlled Mixer

- 3-Channel Remote-Controlled Audio Mixer
- VCA Level Control for Each Input Pair
- Format-A Twisted Pair Inputs
- Balanced and Unbalanced Outputs
- Two Mono Unbalanced Outputs to Feed Stereo Amplifier
- Inputs and Outputs on Detachable Connectors
- Twisted Pair Interconnection to Remote Control
- Directly Controlled by RDL Remote Controls
- Two and Three Channel Remote Controls Available
- Local Input Available if Only Two Twisted Pair Inputs Used
- Paging Source May Connect to Local Input
- Front-Panel Gain Trim Matches Active or Passive Format-A Senders
- Dual-LED VU Meter Displays Mixer Output Level
- Audio Presence Detector Controls Open-Collector Outputs
- Detector Outputs Intended to Enable Power Amplifiers or System Power
- Energy Savings Possible Using Detector Outputs
- Selectable 10 or 20 Minute Detector Release Delay



### ASSOCIATED REMOTE CONTROL EXAMPLES:

- ▶ D-RC2 and DS-RC2 Two-channel remote controls
- ▶ D-RC2M and DS-RC2M Two-channel remote controls with muting
- ▶ D-RC3 and DS-RC3 Three-channel remote controls
- ▶ D-RC3M and DS-RC3M Three-channel remote controls with muting

### TYPICAL APPLICATIONS:

- ▶ Meeting Rooms
- ▶ Boardrooms
- ▶ Classrooms
- ▶ Restaurant or Residential Patios
- ▶ Retail Stores

The FP-TPX3A is a mono audio mixer in the convenient line of FLAT-PAK products, featuring the superior engineering and components common to RDL products. The FP-TPX3A may be rack or surface mounted with optional FLAT-PAK series accessories. The FP-TPX3A gives you the advantages of a quality audio mixer with the added convenience of remote control!

The FP-TPX3A is the ideal choice where a user-accessible mixer must control the volume of multiple sources in a zone. RDL Format-A twisted pair audio senders connect directly to the mixer, allowing each user input to be balanced or unbalanced, mic or line level. FP-TPX3A outputs are provided in balanced and unbalanced formats. Two unbalanced outputs are available to feed the mono mixer output to a stereo amplifier input. Remote control of the mixer allows audio signals to be kept at a single equipment location. Audio is mixed by VCA circuits that are adjusted by control signals from the remote control.

Two Format-A jacks are provided for signal inputs. If the Format-A senders are daisy-chained, only one of the input jacks is used. The other input jack may be used to receive another Format-A sender, or may be used to loop the received Format-A signals out to additional Format-A mixers or receivers. The FP-TPX3A provides power to all connected active senders. The FP-TPX3A is designed to mix the three Format-A audio signals from pairs A, B and C. A front-panel switch allows the PAIR C mixer input to be fed either from the twisted pair C input signal or from a local input. A detachable terminal block is provided to connect a local paging or music source to the **LOCAL INPUT**. *Note: Pair C signals are passed through both Format-A input jacks even if the mixer is set to use a local source instead of the PAIR C twisted pair source.*

Format-A senders are available in active and passive models. Passive Format-A models with unbalanced input jacks send a lower signal level to the mixer than is sent by active senders or by passive senders with balanced inputs. Each **INPUT GAIN** control is calibrated to be adjusted clockwise for an unbalanced passive sender; counter-clockwise for an active sender or passive sender with a balanced input.

A standard RDL dual-LED VU meter provides visual indication of the output level from the mixer. Each input channel operates at unity gain when the corresponding remote control is adjusted to maximum. This assures ample headroom at all normal operating levels. The mixer output is mono. The output is available on a single balanced detachable terminal block or on two unbalanced RCA jacks intended to connect directly to the stereo input of a power amplifier.

The **AUDIO** LED illuminates whenever audio is present at the output of the mixer, defined as greater than 35 dB below +4 dBu. This threshold triggers the **AUDIO DETECT OUTPUTS**. Two open collectors are provided on a detachable terminal block. One of these terminals switches low when audio is present, and may be used to switch amplifiers or other system components on. The other terminal is pulled low when audio is not present. It is intended for muting the digital carrier of power amplifiers equipped for remote muting. Either of these terminals may be used to trigger a variety of other RDL modules or OEM equipment. The use of these terminals to shut down unused equipment can produce effective system energy and cost savings. These control terminals normally remain triggered for 10 minutes after audio is absent. The delay can be increased to 20 minutes using a ground jumper on the terminal block.

The mixer levels are set by RDL remote controls that connect directly to the FP-TPX3 through an RJ45 jack using standard twisted pair cable. The control ports on the mixer and remote controls are color-coded light blue to distinguish them from standard Format-A jacks. The mixer provides power to the remote control. Either a two or three channel remote control may be used. If remote mixing of only two channels is needed, a two channel remote may be used. Pair C becomes the input channel that is not remotely controlled. The **PAIR C/LOCAL INPUT** can be left active at unity gain, typically for a paging source, or may be disabled by a switch set during installation. If the cable connected to the remote control becomes disconnected, the mixer output mutes.



**RDL**<sup>®</sup>  
Radio Design Labs

SPECIALISTS IN PRACTICAL PRECISION ENGINEERING™

**FLAT-PAK™ SERIES**  
**Model FP-TPX3A**  
**Format-A Twisted Pair**  
**Remote Controlled Mixer**

**Installation/Operation**

EN55103-1 E1-E5; EN55103-2 E1-E4  
Typical Performance reflects product at publication time exclusive of EMC data, if any, supplied with product. Specifications are subject to change without notice.

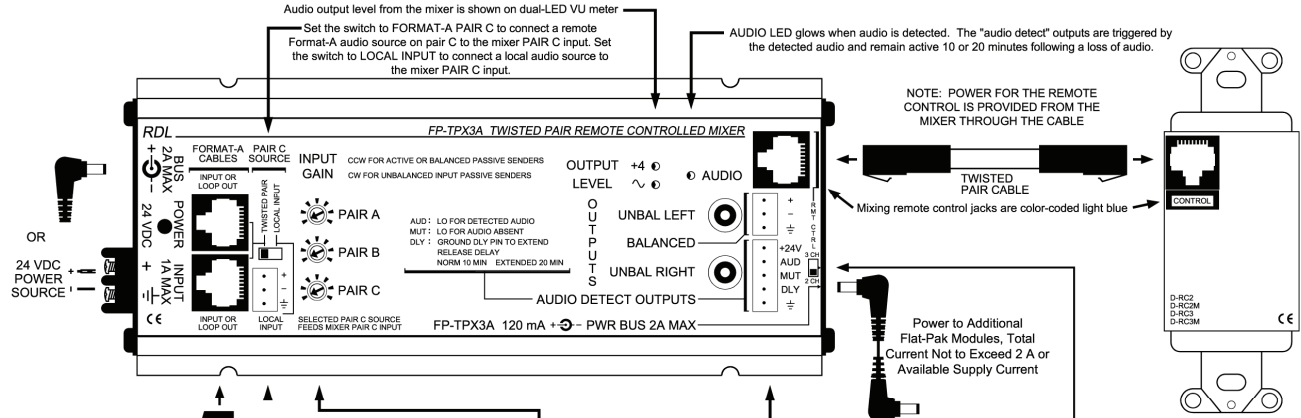

Connect one, two or three FORMAT-A Senders to the RJ45 jacks. Set the senders to provide one signal source on Pair A, one on Pair B and one on Pair C. If only two signals are planned, set the senders to feed the signals on Pairs A and B. If only two signals are received through the RJ45 jacks, a third input may be connected locally to feed the mixer's Pair C input. This input connects on the terminal block.

Set the gain control fully counter-clockwise if an active sender module is feeding the input pair

Set the gain control fully clockwise if a passive sender module is feeding the input pair

Note: If the local Pair C input terminal block is fed from an unbalanced -10 dBV source, set its gain control fully clockwise. Set counter-clockwise if a balanced +4 dBu source is connected.

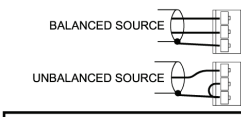

**AUDIO DETECT / CONTROL OUTPUT CONNECTIONS**

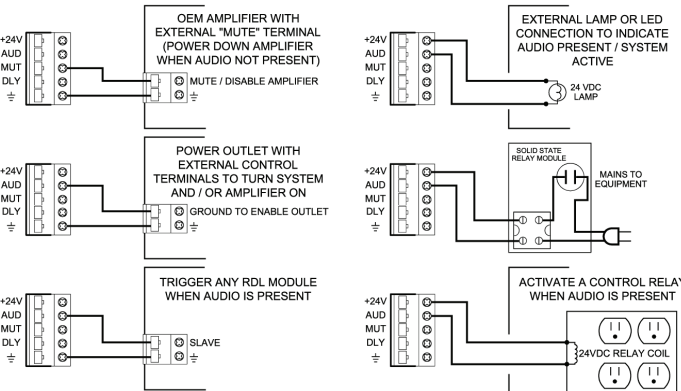

**AUDIO OUTPUT CONNECTIONS**

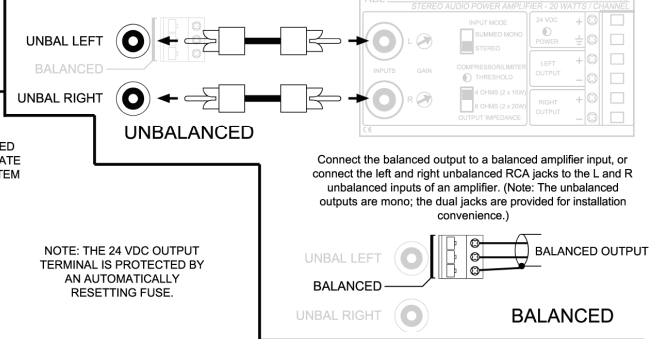

THE "AUD" AND "MUT" OUTPUT CONTROL TERMINALS SWITCH UPON DETECTION OF AUDIO ("AUD" SWITCHES LOW; "MUT" RELEASES) AT THE MIXER OUTPUT AND REMAIN IN THAT STATE UNTIL THE AUDIO HAS BEEN ABSENT FOR 10 MINUTES AT WHICH TIME THEY TOGGLE TO THE OPPOSITE STATE ("MUT" SWITCHES LOW; "AUD" RELEASES). THE DELAY MAY BE EXTENDED FROM 10 TO 20 MINUTES BY INSTALLING THE JUMPER AS SHOWN BETWEEN "DLY" TERMINAL AND GROUND.

**TYPICAL PERFORMANCE**

Inputs (3):  
Input Connections:  
Outputs (3):  
Output Connections:  
Output Level:  
Frequency Response:  
THD+N:  
Noise below +4 dBu:  
Headroom above +4 dBu:  
CMRR:  
VCA attenuation:  
Indicators (3):  
Power Connections (3):  
Power Requirement:  
Overall Dimensions:

RDL FORMAT-A: Balanced line level  
RJ45 (FORMAT-A); Detachable Terminal Block (Pair C)  
150 Ω balanced; 1 kΩ unbalanced (2)  
Detachable Terminal Block (balanced); RCA Phono Jacks (unbalanced)  
+4 dBu balanced, -10 dBV unbalanced  
20 Hz to 20 kHz (+/- 0.25 dB)  
< 0.05% (20 Hz to 20 kHz); < 0.02% (1 kHz)  
< -100 dB (all channels off); < -75 dB (any channel on); < -70 dB (all channels on)  
> 18 dB  
> 80 dB (50 Hz to 150 Hz)  
> 90 dB (each input, remote control volume off)  
Dual-LED VU meter (2); Audio present (threshold = 35 dB below +4 dBu output)  
Terminal block; dc power jack (2)  
24 Vdc @ 120 mA plus connected FORMAT-A sender currents  
Height: 1.42 in. 3.61 cm  
Width: 3.25 in. 8.26 cm  
Length: 8.14 in. 20.68 cm

NOTE: This equipment has been tested and found to comply with the limits for a Class B digital device, pursuant to part 15 of the FCC Rule. These limits are designed to provide reasonable protection against harmful interference in a residential installation. The equipment generates, uses and can radiate radio frequency energy and, if not installed and used in accordance with the instructions, may cause harmful interference to radio communications. However, there is no guarantee that interference will not occur in a particular installation. If this equipment does cause harmful interference to radio or television reception, which can be determined by turning the equipment off on, the user is encouraged to try to correct the interference by one or more of the following measures:

- Reorient or relocate the receiving antenna
- Increase the separation between the equipment and receiver
- Connect the equipment into an outlet on a circuit different from that which the receiver is connected.
- Consult the dealer or an experienced radio/TV technician for help.

**Radio Design Labs Technical Support Centers**

**U.S.A. (800) 933-1780, (928) 778-3554; Fax: (928) 778-3506**  
**Europe [NH Amsterdam] (+31) 20-6238 983; Fax: (+31) 20-6225-287**