

TX™ SERIES

Model TX-MX2R

Audio Mixer / Distribution Amplifier

ANYWHERE YOU NEED...

- To Mix Two Unbalanced Audio Signals
- To Combine Stereo into Mono
- Gain Trim for Each Input
- Two Active Isolated Outputs from the Input Signal(s)
- Isolation between Inputs
- High Quality Unbalanced Audio

You Need The TX-MX2R!



The TX-MX2R is part of the group of versatile TX series from Radio Design Labs. TX series feature the advanced circuitry for which RDL products are known, combined with durable, quality connectors. The ultra-compact TX series can be mounted in limited space using the adhesive methods popularized by RDL's STICK-ON® Series. The TX-MX2R may be mounted directly to a backboard or chassis using a variety of mounting options available from RDL.

APPLICATION: The TX-MX2R is the ideal choice in installations requiring the active, isolated mixing of two unbalanced line-level audio sources to feed either one or two unbalanced destinations.

The input circuits are high-impedance, line level (-10 dBV) and are each isolated from each other. Therefore the modules may be used to bridge an unbalanced stereo source without affecting the stereo separation. Each output from the TX-MX2R would be a mono mix of the stereo signal. Normally, the gain trimmers are set to unity gain. If either channel is low, the gain of that channel may be adjusted up to 6 dB.

The TX-MX2R may also be used to mix two separate sources into a single output. The mixing circuit in the module is an active summing amplifier.

The output driver provides two separate, identical output signals from the input signal(s). This output distribution amplifier therefore allows the TX-MX2R to be used as a two-output audio distribution amplifier. If it is desired to distribute a single source to two destinations, one of the inputs may be left unused without any loss of performance.

The TX-MX2R may be operated from any power supply voltage between 12 Vdc and 33 Vdc. The module's normal operating voltage is 24 Vdc. At operation from a 12 Vdc supply, the headroom remains greater than 18 dB.

For unbalanced, connectorized 2-channel audio mixing and distributing, the TX-MX2R is the ideal choice. Use the TX-MX2R individually, or combine it with other RDL RACK-UP®, STICK-ON, TX or FLAT-PAK™ series audio or video modules as part of a complete audio/video system.

TX™ SERIES

Model TX-MX2R

Audio Mixer / Distribution Amplifier

Installation/Operation



EN55103-1 E1-E5; EN55103-2 E1-E4
Typical Performance reflects product at publication time
exclusive of EMC data, if any, supplied with product.
Specifications are subject to change without notice.

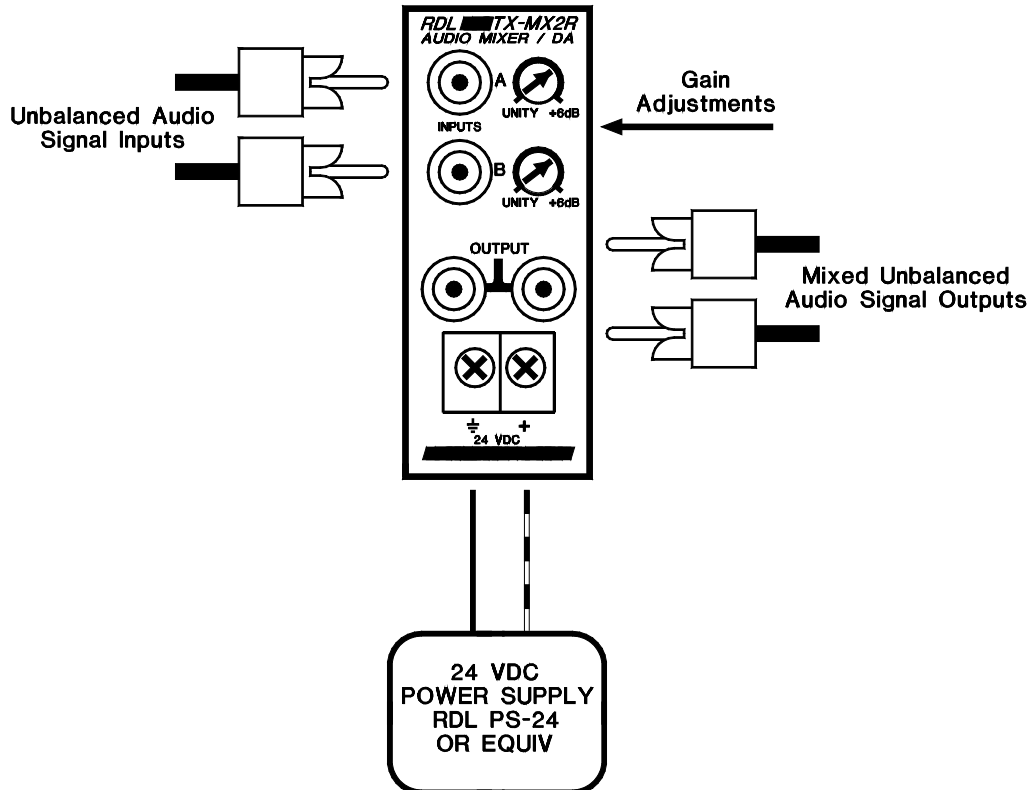

TYPICAL PERFORMANCE

Inputs Level:	2 @ -10 dBV
Input Impedance:	10 k Ω bridging
Noise:	< -75 dB (referenced to -10 dBV)
THD+N:	< 0.050% (0.010% typical)
Frequency Response:	25 Hz to 45 kHz (+/- 0.5 dB) 15 Hz to 70 kHz (+/- 1 dB)
Gain (per channel):	Unity to +6 dB nominal (adjustable)
IMD:	0.010% typical
Outputs (2):	2 @ 100 Ω , -10 dBV to drive low or high impedance unbalanced lines
Headroom:	> 27 dB (24 Vdc supply) > 18 dB (12 Vdc supply)
Power:	24 to 33 Vdc @ 10 mA, Ground-referenced 12 Vdc (headroom remains greater than 18 dB)
Dimensions:	Height: 1.4 in. 3.6 cm Length: 3.0 in. 7.6 cm Width: 1.2 in. 3.0 cm

Radio Design Labs Technical Support Centers

U.S.A. (800) 933-1780, (928) 778-3554; Fax: (928) 778-3506

Europe [NH Amsterdam] (+31) 20-6238 983; Fax: (+31) 20-6225-287