



RDL[®]
Radio Design Labs

SPECIALISTS IN PRACTICAL PRECISION ENGINEERING™

STICK-ON[®] SERIES

Model ST-MA2

Muting Monitor Amplifier

ANYWHERE YOU NEED...

- A Single Speaker Monitor Amplifier
- A Conferencing Monitor Amp
- A Monitor Amp with Muting and Externally Actuated Attenuation Steps
- Fast, Silent Audio Switching
- Multiple Control Inputs
- Adjustable Gain

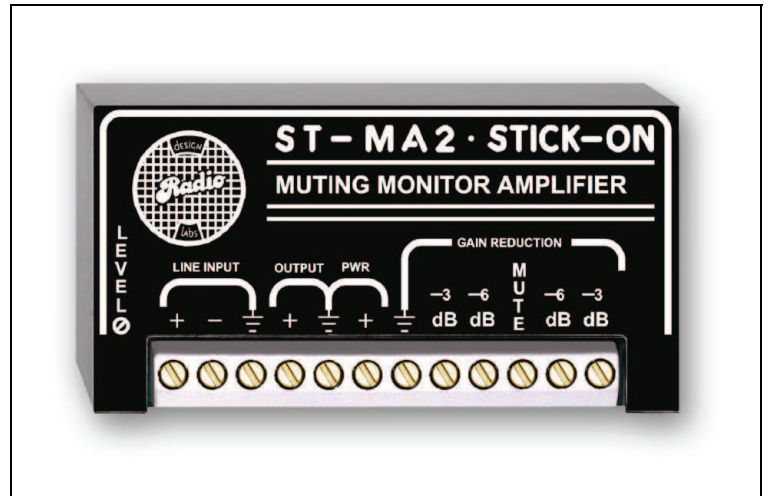

You Need The ST-MA2!

The ST-MA2 is part of a group of products in the STICK-ON Series from Radio Design Labs. The durable bottom adhesive permits quick, permanent or detachable mounting nearly anywhere or it may be used with RDL's racking accessories. The ST-MA2 offers the ultimate in totally solid-state muting and attenuation switching, with the big *plus*, you can put it right where you need it!

APPLICATION: The ST-MA2 is a compact audio monitor amplifier with control inputs to mute or reduce the gain of its output. This module may be used in conjunction with other RDL modules to configure automatic mixing systems or may be used alone as a single speaker monitor amplifier. The ST-MA2 is typically used to drive a small tabletop or overhead monitor speaker in a conference room, boardroom, courtroom, public forum panel or similar installation. The ST-MA2 is ideally suited for use in automatic mixing systems due to its control inputs.

The line-level input may be wired balanced or unbalanced. The audio output will drive standard speakers from 4 to 45 ohms. Normal gain is preset by means of a trimmer on the module.

Five control inputs are provided. An open-collector, a switch closure, or compatible logic signals may activate each. Typically, an RDL ST-GSP1 Gated Speech Preamplifier controls these inputs. There is a control input which mutes the ST-MA2 output completely. This may be used to prevent feedback if there is a pickup mic associated with the speaker driven by the ST-MA2. Two control terminals are provided to attenuate the ST-MA2 output by 3 dB, and two additional terminals are provided to attenuate the output by 6 dB. These connect from the mic logic (or open-collector) control signals from gated mic preamps for adjacent and second adjacent locations.

With muting, 3 dB, and 6 dB attenuation control inputs provided, the ST-MA2 is the ultimate in versatile monitoring options in many multiple-mic environments.

STICK-ON[®] SERIES

Model ST-MA2

Muting Monitor Amplifier

Installation/Operation



EN55103-1 E1-E5; EN55103-2 E1-E4
Typical Performance reflects product at publication time exclusive of EMC data, if any, supplied with product. Specifications are subject to change without notice.

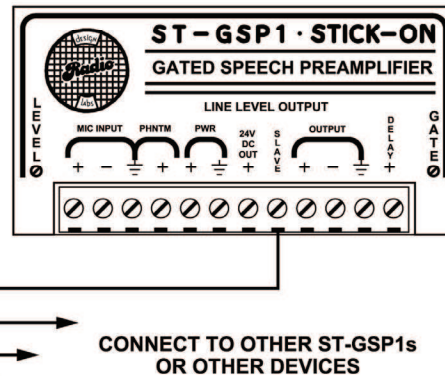
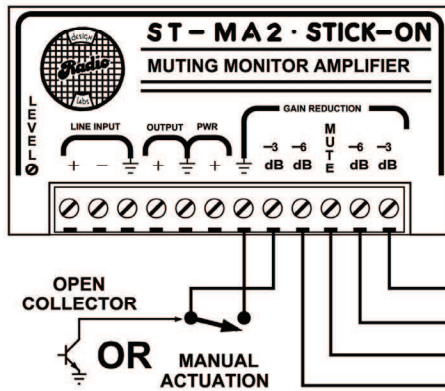
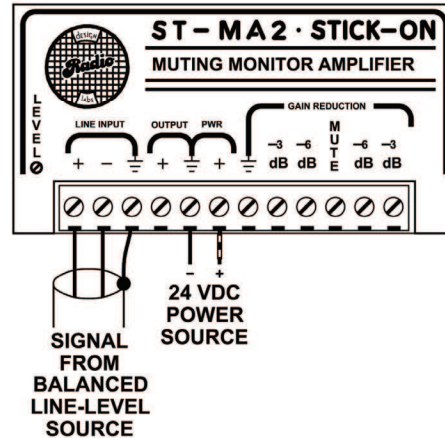
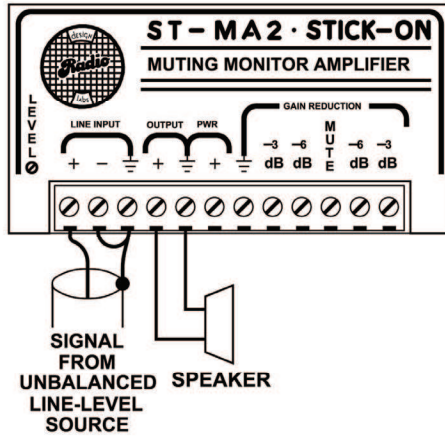

TYPICAL PERFORMANCE

| | |
|-------------------------|--|
| Input Impedance: | 20 k Ω balanced or unbalanced bridging |
| Input level: | -10 dBv minimum for 2 Watts RMS output |
| Output Impedance: | 8 Ω (will drive 4 Ω loads) |
| Output Power: | 1.75 Watts RMS continuous; 2 Watts RMS max. |
| THD + N: | < 0.500% |
| Bandwidth: | 45 Hz to 14 kHz |
| CMRR: | > 60 dB (50 Hz to 120 Hz) |
| Residual Noise: | < -80 dB below 2 Watts RMS |
| Switching Time: | < 50 μ s |
| Attenuation (Muted): | > 90 dB @ 1 kHz > 85 dB 300 Hz to 3 kHz > 75 dB 20 Hz to 20 kHz |
| Selectable Attenuation: | 3 or 6 dB, each setting individually selectable using two independent inputs (connect to ground to activate) |
| Power: | 24 to 33 Vdc @ 200 mA, Ground-referenced, for rated output (220 mA for 2 Watts RMS) |

Radio Design Labs Technical Support Centers

U.S.A. (800) 933-1780, (928) 778-3554; Fax: (928) 778-3506

Europe [NH Amsterdam] (+31) 20-6238 983; Fax: (+31) 20-6225-287