

TX™ SERIES

Model TX-1W

Music-on-Hold Amplifier

ANYWHERE YOU NEED...

- To Feed Audio into Telephone Equipment Music-on-Hold Input
- Adjustable Audio Level
- Optimized Sound Quality
- Unbalanced Output up to 1 Watt
- Balanced Transformer-driver Output
- Ultra Compact Size

You Need The TX-1W!



The TX-1W is part of the group of versatile TX products from Radio Design Labs. The TX series features the advanced circuitry and high-quality connectors for which RDL products are known, combined with durable, quality connectors. The ultra-compact TX series can be mounted in limited space using the adhesive methods popularized by RDL's STICK-ON™ Series. The TX-1W may be mounted directly to a backboard by removing the hole caps at each end, and fastening two mounting screws (provided) through the TX case directly into the backboard.

APPLICATION: The TX-1W is the ideal choice in on-site installations where the telephone switching unit (KSU) needs to be fed with music, voice or combined music/voice signals.

There are a wide variety of telephone instruments in use. When a caller is placed on hold, the audio quality perceived is affected by the caller's own telephone, as well as the telephone lines, central switch and on-site equipment. Due to these variations, conventional audio amplifiers used as music-on-hold drivers frequently produce annoying artifacts at the caller's earpiece. Attempts to reduce listener fatigue through high-frequency roll-off alone tend to produce a muffled, tired sound.

The TX-1W features a spectral response specifically characterized to match the broadest variations in telephone audio distribution producing a lively, crisp, interesting sound without the annoying resonances and distortions prone to creating listener fatigue. A single front-panel control is provided for audio level adjustment.

The TX-1W provides an unbalanced input via a conventional phono jack. Two audio outputs are provided. The unbalanced output can drive virtually any system input impedance. This output is intended to connect to any phone system's unbalanced, connectorized input. The TX-1W will deliver standard line-level signals for typical (-10 dBV) inputs, but is capable of delivering up to 1 watt RMS into 8 Ohm inputs! For systems with a 600 Ohm transformer input, the TX-1W provides an electronically balanced output through the barrier block (a balancing transformer is required for feeding balanced 600 Ω telephone lines).

For music-on-hold installations of any input impedance or audio configuration, the TX-1W is the ideal choice. Use the TX-1W individually, or combine it with other RDL RACK-UP®, STICK-ON®, TX, or FLAT-PAK™ series products as part of a complete audio/video system.

TX™ SERIES

Model TX-1W

Music-on-Hold Amplifier

Installation/Operation



EN55103-1 E1-E5; EN55103-2 E1-E4
Typical Performance reflects product at publication time
exclusive of EMC data, if any, supplied with product.
Specifications are subject to change without notice.

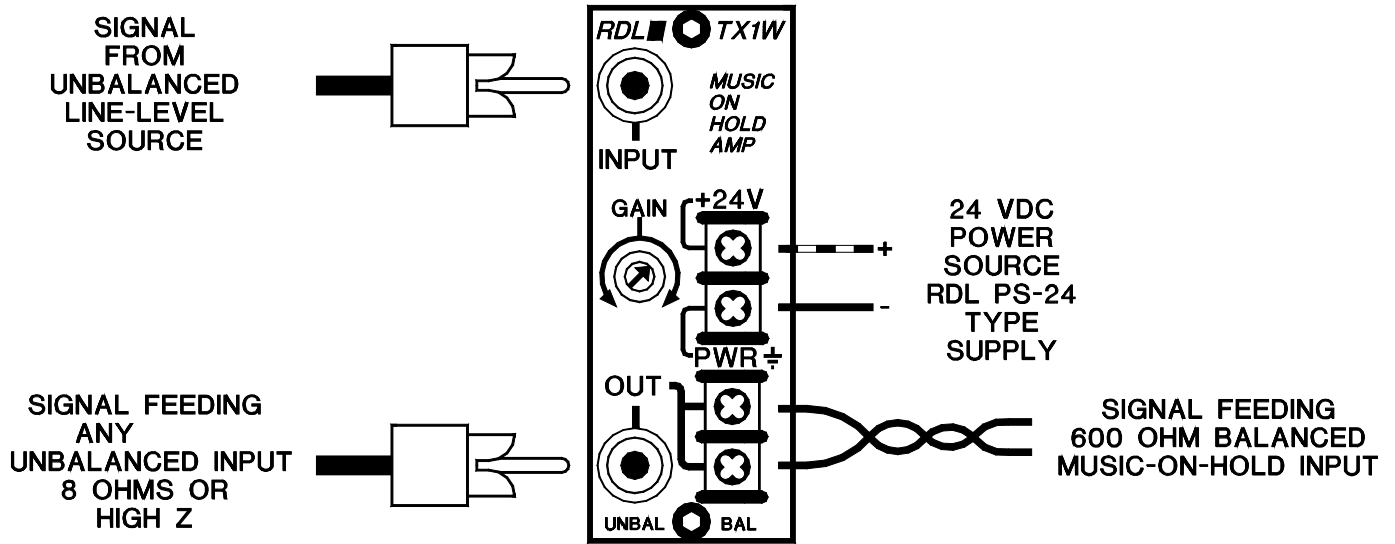

TYPICAL PERFORMANCE

Input:	Unbalanced via standard phono jack
Input Level:	-10 dBV nominal
Gain:	Adjustable -10 dB to +25 dB
Frequency Response:	Tailored to Phone systems within 20 Hz to 20 kHz spectrum
THD+N:	< 0.5% (1 kHz - Maximum Output 1W); < 0.2% (1 kHz @ +4 dBu)
Residual Noise:	< -75 dB (referred to 600 Ω +4 dBu, or to 1W RMS)
Outputs:	1 Balanced @ 600 Ω to drive transformer inputs; 1 Unbalanced adjustable line-level to 1 W
Power Requirement:	24 to 33 Vdc @ 150 mA, Ground-referenced