



RDL[®]
Radio Design Labs

SPECIALISTS IN PRACTICAL PRECISION ENGINEERING™

STICK-ON[®] SERIES

Model ST-RG1

Ramp Generator

ANYWHERE YOU NEED...

- Ramp Generator with 0 to 10 Volt Output
- Remote Control of RDL VCA Products
- Multiple VCA Remote Control Points
- Dual LED Outputs for Position Indication
- Ramp Output Capable of Driving Six VCAs
- Buffered, De-Bounced Switch Inputs

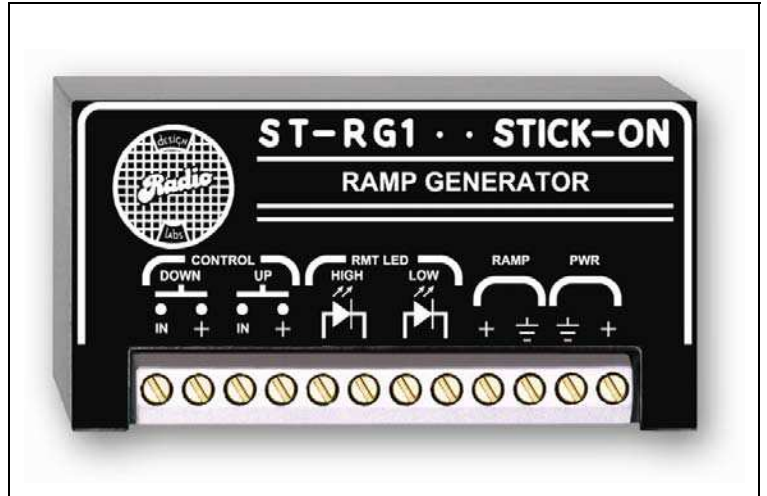

You Need The ST-RG1!

The ST-RG1 is a digitally generated 0 to 10 volt Ramp Generator in the group of STICK-ON series products by Radio Design Labs. These products are designed for quick, convenient installation and reliable operation in a variety of control applications.

APPLICATION: The ST-RG1 provides a 0 to 10V output is the ideal interface to remotely control Voltage Controlled Amplifiers, such as RDL's popular VCA Modules. A single VCA may now be controlled from several locations. Only a pair of buttons (**UP** and **DOWN**) is required at each control location, or RDL's RLC2 Remote Level Control. LED level indicator driver circuitry is included in the ST-RG1.

The ST-RG1 provides terminals for connection of two momentary buttons; one to ramp up, the other to ramp down. This is usually accomplished with RDL's RLC2 Remote Level Control. When power is applied to the ST-RG1, the output terminal is at its lowest (0 volt) point. When the **UP** button is pushed, the output ramps upward. When the **UP** button is released, the output remains stable at the voltage present when the button was released. When the **DOWN** button is depressed, the output ramps downward as long as the button is held in. When the ST-RG1 output reaches either minimum or maximum, it remains there until the opposite button (or closure) is applied. If the remote button is pushed momentarily and not held in, the ramp will step 200 millivolts nominal in the selected direction.

Two LED outputs are provided. A red LED connects to the **LOW** output; a green connects to the **HIGH** output. When the ramp is fully on (10 volts), the **HIGH** indicator is fully on, and the **LOW** is fully off. When the ramp is at minimum, the **LOW** is fully on and the **HIGH** is fully off. The circuit is designed to vary the current to each LED in proportion to the relative position of the ramp. If the ramp is at 5 volts then both indicators are equally illuminated. With this system, only two LEDs are required for full visual level indication!

The ST-RG1 provides the ideal interface for audio volume control through RDL VCA Modules. The ST-RG1 is a ground-referenced product, which may operate from the same power supply as the RDL VCA modules. Any number of **UP** and **DOWN** buttons may be connected to the ST-RG1, allowing VCA control from multiple locations. The output drive current from the ST-RG1 is more than sufficient to drive six monaural RDL VCA Modules for stereo applications.

All this is available in the unbelievable compactness and convenience of the RDL STICK-ONS. Put them right where you need them, or design them in with our optional racking or mounting kits. Anytime you need a 0 to 10 volt ramp generator, your simple, cost-effective solution is found in the ST-RG1!

STICK-ON® SERIES

Model ST-RG1 Ramp Generator

Installation/Operation



EN55103-1 E1-E5; EN55103-2 E1-E4
Typical Performance reflects product at publication time exclusive of EMC data, if any, supplied with product. Specifications are subject to change without notice.

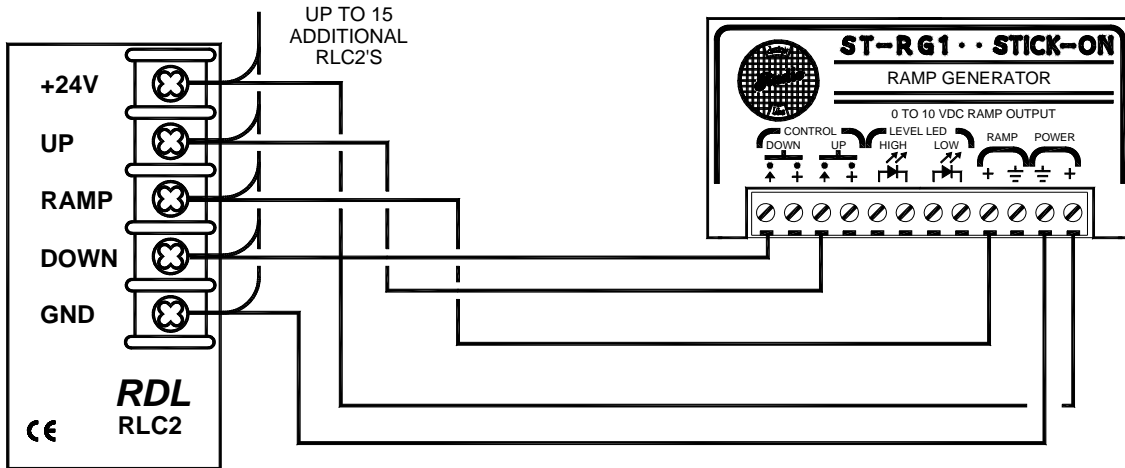

CONNECTING ST-RG1 TO RDL'S RLC2s

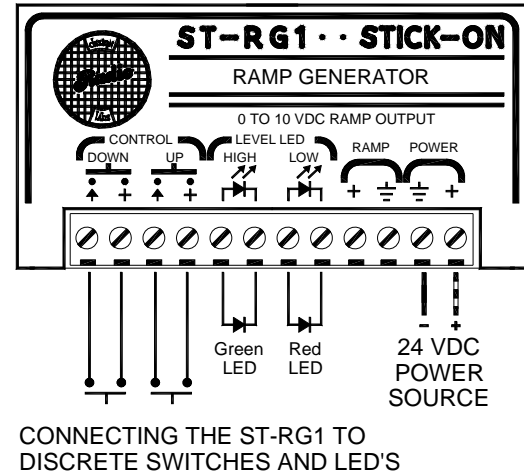
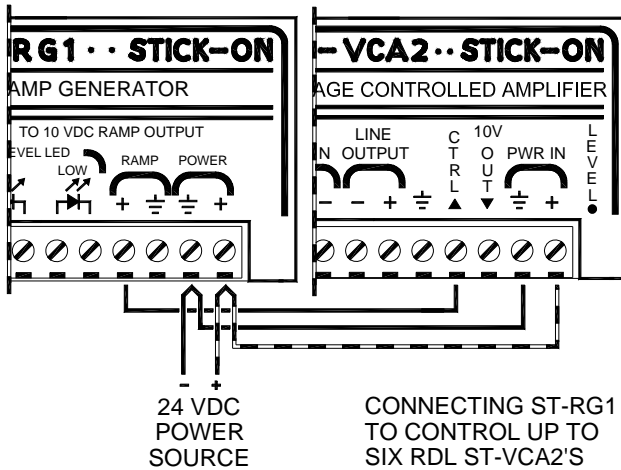

TYPICAL PERFORMANCE

Control Inputs:
Input Logic:

Indicator Outputs:

LED Output Current:
Ramp Output:

Minimum Step:
Ramp Time:
Power Requirement:

1 to ramp **up**, 1 to ramp **down**
External closure pulls normally low input to +15 Vdc to activate **up** or **down** function
1 to drive low LED, partial to fully Off
1 to drive high LED partial to fully On
0 to 3 mA (to drive low current, high intensity LEDs)
0 to 10 Volts nominal
(typical < 0.1 V to > 9.8 V under ST-VCA1 load)
200 mV nominal
5 seconds (fully off to fully on; or fully on to fully off)
24 to 33 Vdc @ 40 mA, Ground-referenced

NOTE: This equipment has been tested and found to comply with the limits for a Class B digital device, pursuant to part 15 of the FCC Rule. These limits are designed to provide reasonable protection against harmful interference in a residential installation. The equipment generates, uses and can radiate radio frequency energy and, if not installed and used in accordance with the instructions, may cause harmful interference to radio communications. However, there is no guarantee that interference will not occur in a particular installation. If this equipment does cause harmful interference to radio or television reception, which can be determined by turning the equipment off an on, the user is encouraged to try to correct the interference by one or more of the following measures:

- Reorient or relocate the receiving antenna
- Increase the separation between the equipment and receiver
- Connect the equipment into an outlet on a circuit different from that which the receiver is connected.
- Consult the dealer or an experienced radio/TV technician for help.