



RDL[®]
Radio Design Labs

SPECIALISTS IN PRACTICAL PRECISION ENGINEERING™

HALF-RACK SERIES

Model HR-DSX4

Digital Audio Selector



- 4 x 1 Digital Audio Selection with Signal *Reclocking*
- Each Input: AES/EBU, Coaxial or Optical S/PDIF
- Output: AES/EBU, Coaxial or Optical S/PDIF
- Format Conversion for Selected Output Format
- Operation Up to 24 bits, 192 kHz
- Exclusive **SURE-LOK**™ Auto-Recovery Sentinel
- Transformer Isolated AES/EBU Inputs and Output
- Local or Remote Controlled Switching
- Open-Collector Output for Selected Input
- Input LED Flashes if Valid Input is Not Connected

The HR-DSX4 is an RDL HALF-RACK product, featuring an all metal chassis and the advanced circuitry for which RDL products are known. HALF-RACKs may be operated free-standing using the included feet or may be conveniently rack mounted using available rack-mount adapters.

APPLICATION: The HR-DSX4 is the ideal choice in installations requiring high quality source selection between digital audio signals. Solid-state switching is used to select one of four inputs. Each input may be fed through one of three jacks: S/PDIF optical, S/PDIF coaxial or AES/EBU. AES-3ID sources may be connected to the S/PDIF inputs. The selected input is decoded, reclocked and transmitted through the output stage. The output is switch-selectable to provide an AES/EBU, S/PDIF coaxial, S/PDIF optical or AES-3ID output. The switch enables the appropriate output jack and any required electrical and data format conversion. The AES/EBU inputs and output are 110 Ω; the S/PDIF coaxial and AES-3ID input signals connect through 75 Ω terminated phono jacks. RDL's proprietary **SURE-LOK**™ auto-recovery supervision monitors possible causes of latch-up and reinitiates signal lock to provide highly stable operation in the variety of conditions encountered in professional environments.

The front panel features four high-reliability, keyboard-style source selection pushbuttons with corresponding LEDs. Upon selecting a source, the associated input LED lights if a valid digital audio signal is present and flashes if not present. If the button for a selected source is pushed again, all inputs are turned off until the next source selection. A front-panel **LOCAL/REMOTE** switch enables either the front-panel buttons or the rear-panel remote control terminals provided on detachable terminal blocks. In the **REMOTE** mode, inputs are selected by an external momentary switch or open-collector closure to ground. Five remote control terminals are provided; one for each digital audio source, and one to shut **OFF** all inputs. Installing a jumper from the **CT** terminal to ground requires a continuous remote closure when a source is to be switched on, permitting remote control by an RDL RC4-RU wall-mount 4-button Remote Control or OEM equipment. When a source is selected, the HR-DSX4 provides a 50 mA open-collector output to control other equipment or modules.

The HR-DSX4 is powered from 24 Vdc, which may be connected through the detachable terminal block or through the dc power jack. A front-panel power switch is provided.

Use the HR-DSX4 individually, or combine it with other RDL products as part of a complete audio/video system.

HALF-RACK SERIES Model HR-DSX4 Digital Audio Selector

REMOTE CONTROL EXAMPLES:

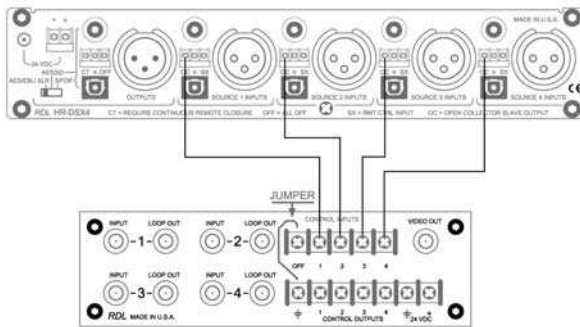
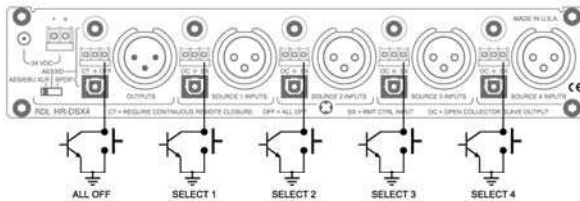
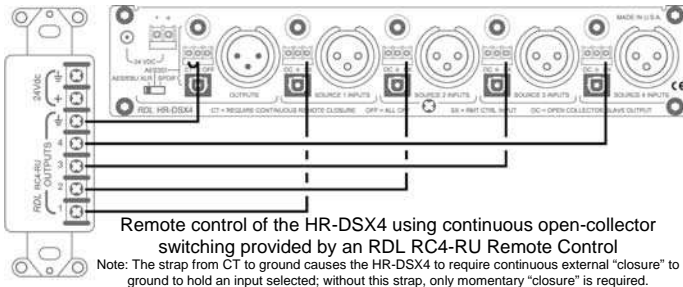

TYPICAL PERFORMANCE

Inputs (12):	110 Ω AES/EBU XLR (4), transformer isolated; S/PDIF optical (4); 75 Ω S/PDIF or AES-3ID coaxial phono jack (4)		
Outputs (3):	110 Ω AES/EBU XLR, balanced transformer isolated; S/PDIF optical; 75 Ω S/PDIF or AES-3ID coaxial phono jack		
Selector:	Rear-panel output format selector: AES/EBU, S/PDIF or AES-3ID		
Sample Rate:	32 kHz to 192 kHz		
Resolution:	16 to 24 bits		
Indicators (6):	POWER LED; INPUT Source Selected LED (4); REMOTE Control Mode LED		
Standards:	AES3-2003, IEC60958		
Power Requirement:	24 to 33 Vdc @ 50 mA, Ground-referenced		
Mounting:	Rack-mount using optional rack adapters such as HR-RA2; or operate free-standing (feet included)		
Dimensions:	Height:	1.7 in	4.3 cm
	Length:	8.6 in	20.6 cm
	Depth:	4.59 in	11.66 cm

Installation/Operation



EN55103-1 E1-E5; EN55103-2 E1-E4

Typical Performance reflects product at publication time exclusive of EMC data, if any, supplied with product. Specifications are subject to change without notice.

CONNECTIONS:

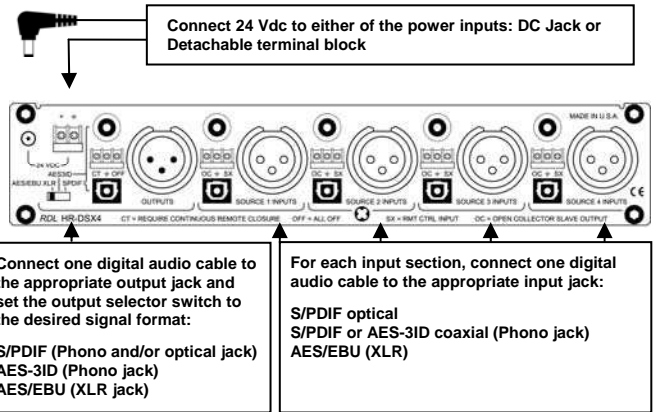

MOUNTING:

For free-standing operation, use the four provided machine screws to mount the feet as shown.
OR
Use the four screws to secure the module to an optional RDL mount, such as an HR-RA2 Rack Adapter.



LABELING:

The front-panel buttons can be conveniently and professionally labeled with a hand-held label printer equipped with 1/4" wide clear label tape.

3. Place Adhesive Label over Laminate in Track

4. Slide Lens back in position, covering the clear adhesive labels. Replace the End Cap.

1. Remove End Cap

2. Slide Lens Out of Track

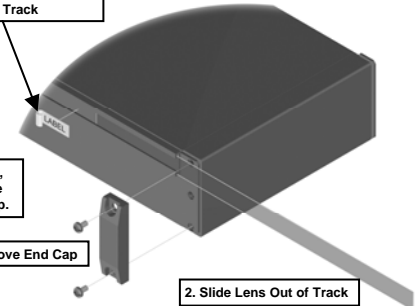

NOTE: This equipment has been tested and found to comply with the limits for a Class B digital device, pursuant to part 15 of the FCC Rule. These limits are designed to provide reasonable protection against harmful interference in a residential installation. The equipment generates, uses and can radiate radio frequency energy and, if not installed and used in accordance with the instructions, may cause harmful interference to radio communications. However, there is no guarantee that interference will not occur in a particular installation. If this equipment does cause harmful interference to radio or television reception, which can be determined by turning the equipment off an on, the user is encouraged to try to correct the interference by one or more of the following measures:

- Reorient or relocate the receiving antenna
- Increase the separation between the equipment and receiver
- Connect the equipment into an outlet on a circuit different from that which the receiver is connected.
- Consult the dealer or an experienced radio/TV technician for help.