



**RDL**<sup>®</sup>  
Radio Design Labs

SPECIALISTS IN PRACTICAL PRECISION ENGINEERING™

## ACCESSORIES

### Models D-CIJ3 and DS-CIJ3 Consumer Input Jacks – Mono

### Models D-CIJ3D and DS-CIJ3D Consumer Input Jacks – Stereo

- Stereo Inputs to Stereo Outputs (D-CIJ3D)
- Stereo Inputs to Mono Output (D-CIJ3)
- Stereo Inputs on RCA Jacks and Stereo Mini-Jack
- Unbalanced to Balanced Conversion Without Gain
- Transformer Isolation for Unbalanced Line Inputs
- Hum Cancellation on Unbalanced Line Inputs
- Line-Level Output to Feed 10 kΩ Equipment Inputs
- Output Connections on Detachable Terminal Block
- Mix Stereo Inputs to Mono Balanced (D-CIJ3, DS-CIJ3)
- Available in RDL White/Gray (D-CIJ3, D-CIJ3D)
- Available in Stainless Steel (DS-CIJ3, DS-CIJ3D)

The D-CIJ3 and D-CIJ3D are Decora®-compatible audio input accessories from Radio Design Labs. All metal enclosures are attractively finished in white or brushed stainless steel to complement the decor encountered in commercial environments. Custom labeling is available at [www.rdlnet.com](http://www.rdlnet.com).

**D-CIJ3 and DS-CIJ3:** The D/S-CIJ3 is the ideal choice in installations requiring the passive mixing of two unbalanced line-level audio sources to feed a mono balanced (or unbalanced) audio line.

The D/S-CIJ3 is a complete unbalanced line-level audio input module. The front panel features two gold plated phono jacks and a single stereo mini-jack, intended for mono or stereo consumer level sources. An input signal may be connected to either the phono jacks or to the mini-jack. The left and right signal inputs are combined and balanced through audio transformers configured to reject induced hum. A mono line-level output is provided on the rear-panel detachable terminal block for connection to a 10 kΩ or higher input impedance line-level module or equipment input.

**D-CIJ3D and DS-CIJ3D:** The D/S-CIJ3D is the ideal choice in installations requiring stereo unbalanced line-level audio sources to feed stereo balanced (or unbalanced) audio lines.

The D/S-CIJ3D is a complete unbalanced line-level audio input module. The front panel features two gold plated phono jacks and a single stereo mini-jack, intended for mono or stereo consumer level sources. An input signal may be connected to either the phono jacks or to the mini-jack. The inputs are balanced through audio transformers configured to reject induced hum. A stereo line-level output is provided on the rear-panel detachable terminal block for connection to 10 kΩ or higher input impedance line-level module or equipment inputs.

The D-CIJ3 and D-CIJ3D are offered in RDL traditional white and gray. The DS-CIJ3 and DS-CIJ3D feature a brushed stainless steel front panel.

Wherever consumer format audio signals need to be connected to a professional audio system, the D-CIJ3 and D-CIJ3D are the ideal choices. Use them individually or in conjunction with other RDL products as part of a complete audio/video system.

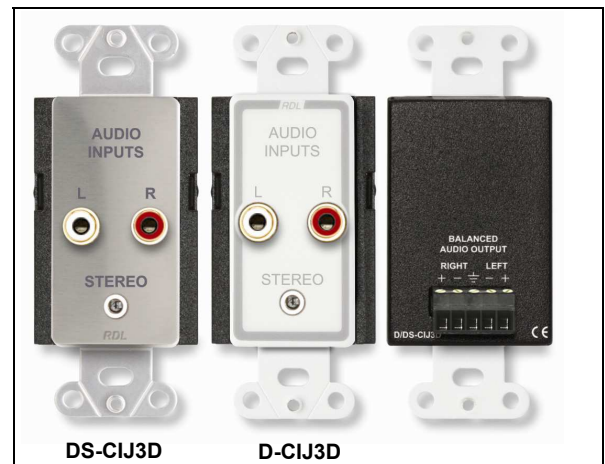
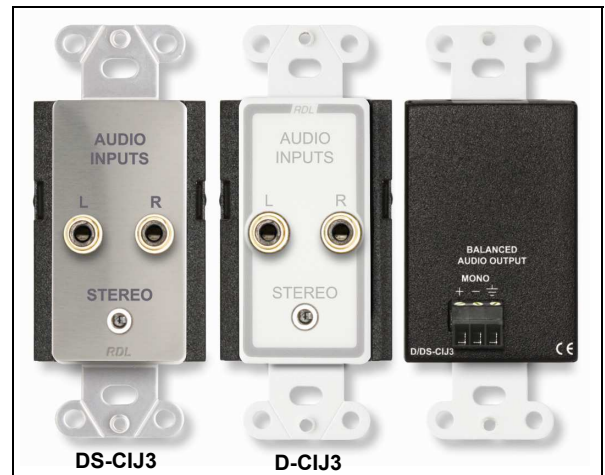

## Installation/Operation

### ACCESSORIES

Models **D-CIJ3** and **DS-CIJ3**  
**Consumer Input Jacks – Mono**

Models **D-CIJ3D** and **DS-CIJ3D**  
**Consumer Input Jacks – Stereo**



EN55103-1 E1-E5; EN55103-2 E1-E4  
Typical Performance reflects product at publication time  
exclusive of EMC data, if any, supplied with product.  
Specifications are subject to change without notice.

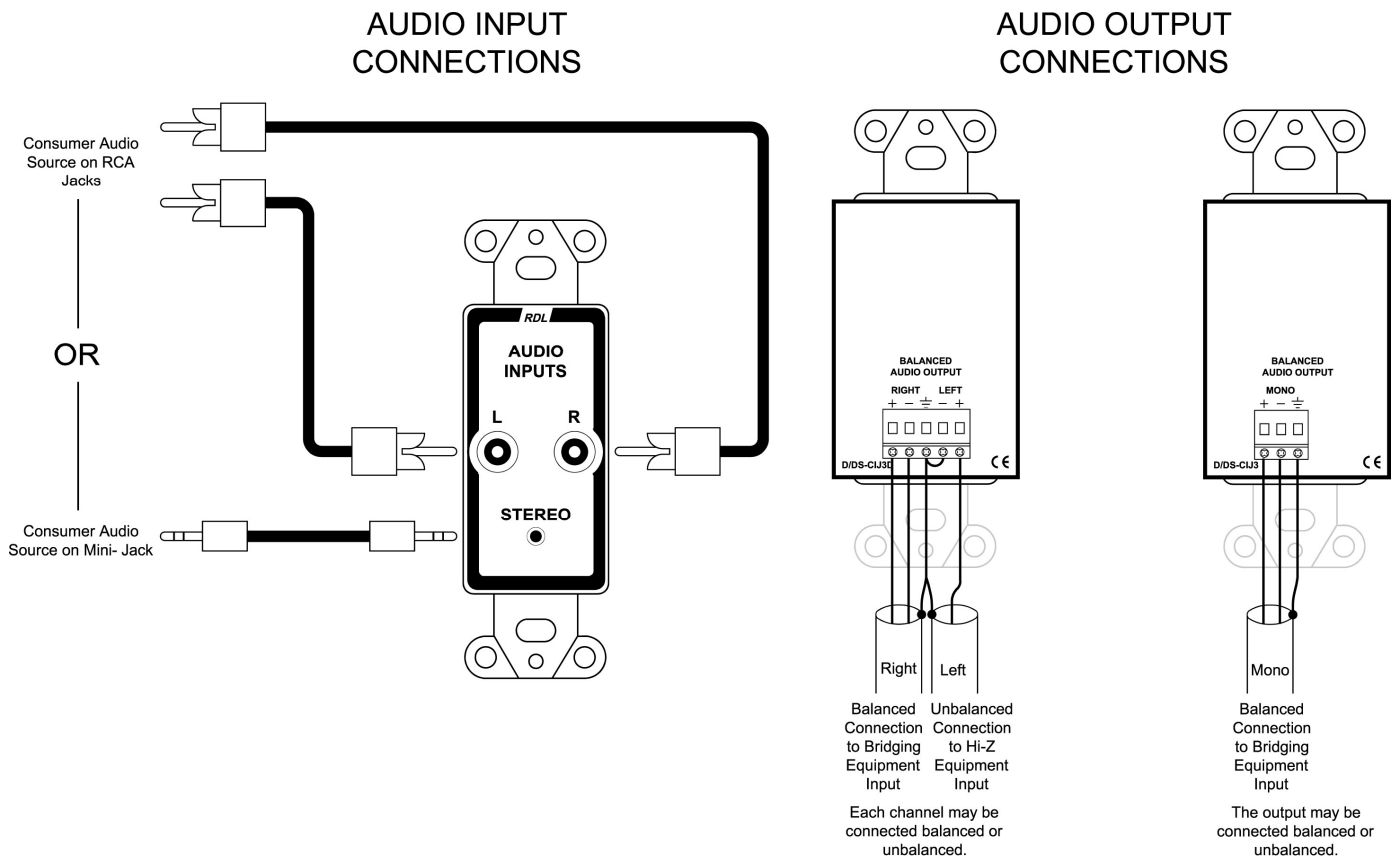

### TYPICAL PERFORMANCE

Input connectors (3):	Phono jacks with gold contacts (Left and Right), Mini-jack 3.5 mm (Stereo)
Frequency response (line level):	50 Hz to 20 kHz ( $\pm 1$ dB); 30 Hz to 20 kHz ( $\pm 2$ dB)
Crosstalk (D-CIJ3D):	<-80 dB (1 kHz); <-60 dB (10 Hz to 20 kHz)
THD:	<0.2% (1 kHz)
Output connector:	Detachable terminal block
Dimensions:	Height: 4.13 in. 10.49 cm
	Width: 1.7 in. 4.32 cm
	Depth: 2.15 in. 5.47 cm
Mounting Box Minimum Dimensions:	Width: 1.80 in. 4.57 cm
	Depth: 1.75 in. 4.45 cm

Radio Design Labs Technical Support Centers

U.S.A. (800) 933-1780, (928) 778-3554; Fax: (928) 778-3506

Europe [NH Amsterdam] (+31) 20-6238 983; Fax: (+31) 20-6225-287