



# RDL<sup>®</sup>

Radio Design Labs

SPECIALISTS IN PRACTICAL PRECISION ENGINEERING™

## ACCESSORIES

### Models D-RLC3, DS-RLC3, DB-RLC3

#### Remote Level Control



- Remote Selection of Preset Audio
- Pushbutton Level Selection
- 4 Selectable System Levels, or Three Levels + OFF
- Connections on Detachable Terminal Block
- Premium Quality Remote Panel
- Professional Aesthetic Appearance
- Ultra-Compact All Metal Construction
- LED Indication (Green)

The D SERIES-RLC3 is part of the group of versatile wall-mounted products from Radio Design Labs. The standard mounting case can be directly fastened in North American electrical boxes or in RDL International wall boxes.

**APPLICATION:** The D-RLC3 is the ideal choice where sound levels are to be controlled from a single remote location, and where predetermined preset levels are desired.

The D-RLC3 is designed to directly interface with RDL control modules which feature a 0 to 10 Vdc control input utilizing an external 10 k $\Omega$  resistive control, such as the ST-VCA3, RU-VCA2A and RU-VCA6A voltage controlled amplifiers. The D-RLC3 has four momentary pushbuttons, each corresponding to one of four levels selected. The LEDs next to each pushbutton indicate which level is presently selected.

In a typical installation, the D-RLC3 is wired to an RDL VCA. The D-RLC3 runs from the same power supply as the VCA. When power is applied, the D-RLC3 defaults to the **NORM** level. One higher level, **HIGH**, and two lower levels, **LOW** and **MIN**, are then available for selection. When the D-RLC3 is set to the **HIGH** position, the VCA is at maximum gain. The **NORM**, **LOW**, and **MIN** levels are each adjustable by the installer using trimmers on the front of the D-RLC3. Once installed, the adjustments are concealed from the user.

The D-RLC3 is the ideal choice in stores, meeting rooms and facilities where continuous user control of levels is not permitted or desired. The system designer can decide how much overall boost or cut should be available. The **MIN** level may be set to full attenuation, allowing the system level to be stepped the prescribed amount above normal, below normal, or off. As supplied from RDL, **HIGH** is nominally 4 dB above **NORM**, **LOW** is 4 dB below **NORM**, and **MIN** is set to off.

The D-RLC3 is constructed on a durable polycarbonate-faced, powder-coated steel panel. Electronics are housed in a metal enclosure featuring a rear panel detachable terminal block for easy wiring. The attractive front-panel graphics and quality construction make the D-RLC3 the ideal choice in any high quality and economical wall-mounted remote control installation.

## ACCESSORIES

### Models D-RLC3, DS-RLC3, DB-RLC3 Remote Level Control

#### Mounting

The D SERIES-RLC3 should be mounted in an RDL WB-1U wall box or equivalent. The ambient operating environment must not exceed 40 degrees C.

## Installation/Operation



EN55103-1 E1-E5; EN55103-2 E1-E4; EN60065  
Typical Performance reflects product at publication time exclusive of EMC data, if any, supplied with product. Specifications are subject to change without notice. This product is Professional Apparatus.

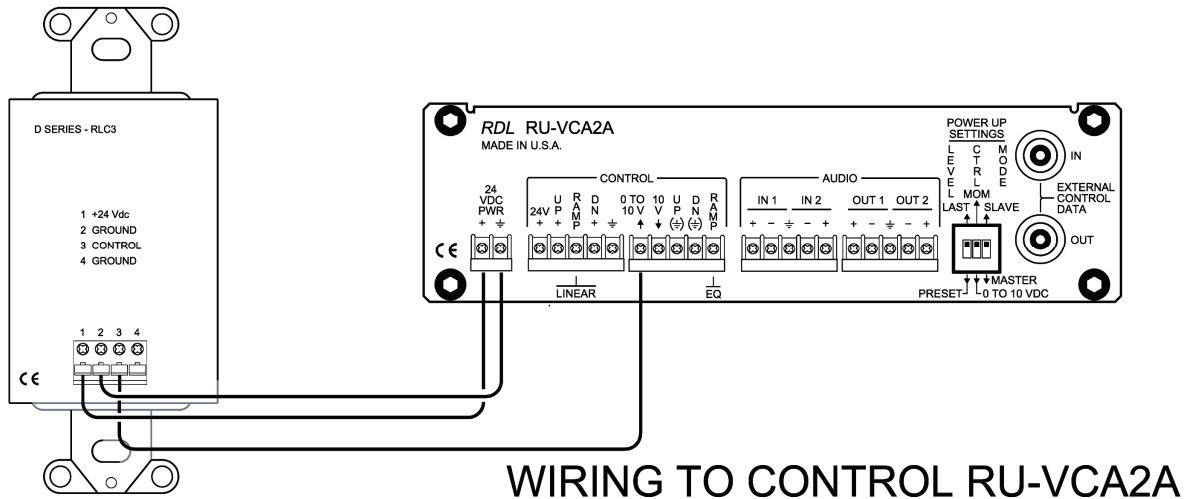
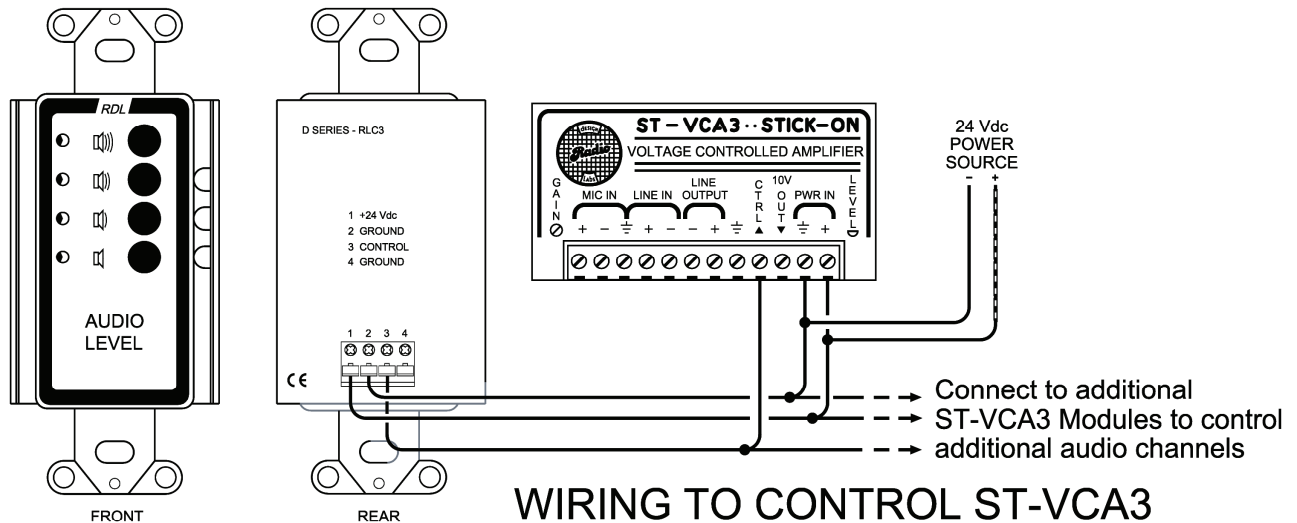

### TYPICAL PERFORMANCE

Interface:

Direct connection to RDL VCA modules using 0 to 10 Vdc control or 10 kΩ resistive control (see ST-VCA3)

Output:

Selectable resistance (**CTRL** Terminal) to ground in four steps:

#### D-RLC3 OUTPUT

**HIGH:** 10 kΩ  
**NORM:** Adjustable  
**LOW:** Adjustable  
**MIN:** Adjustable

#### RDL VCA GAIN

0 dB  
-3 dB to -20 dB  
-5 dB to -35 dB  
-10 dB to OFF

Power Requirements:

24 Vdc @ 30 mA, Ground-referenced

Mounting:

Mounts in standard US electrical outlet box; cover plate available separately.

Dimensions:

Height: 4.1 in. (10.4 cm)

Depth: 1.6 in. (4.10 cm)

Width: 1.3 in. (3.30 cm)

### Radio Design Labs Technical Support Centers

U.S.A. (800) 933-1780, (928) 778-3554; Fax: (928) 778-3506

Europe [NH Amsterdam] (+31) 20-6238 983; Fax: (+31) 20-6225-287