

# ACCESSORIES

## Model RT2

### Remote Control Selector

## Installation/Operation



EN55103-1 E1-E5; EN55103-2 E1-E4  
Typical Performance reflects product at publication time exclusive of EMC data, if any, supplied with product. Specifications are subject to change without notice.

The RT2 can control any RDL Module that has a SLAVE terminal, or any Device with a Pull-to-Ground Terminal

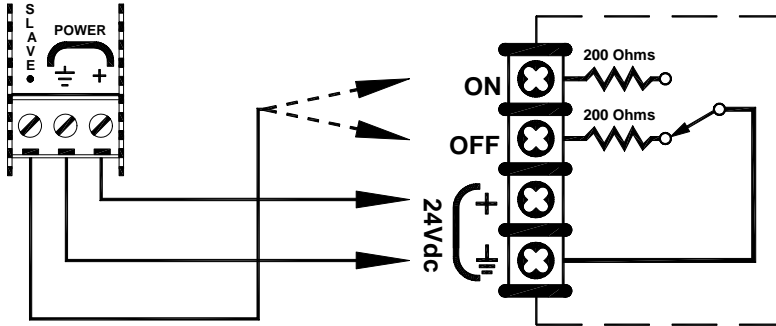

Functional Equivalent to Internal Solid State Switching Circuit

### Typical Connection Example

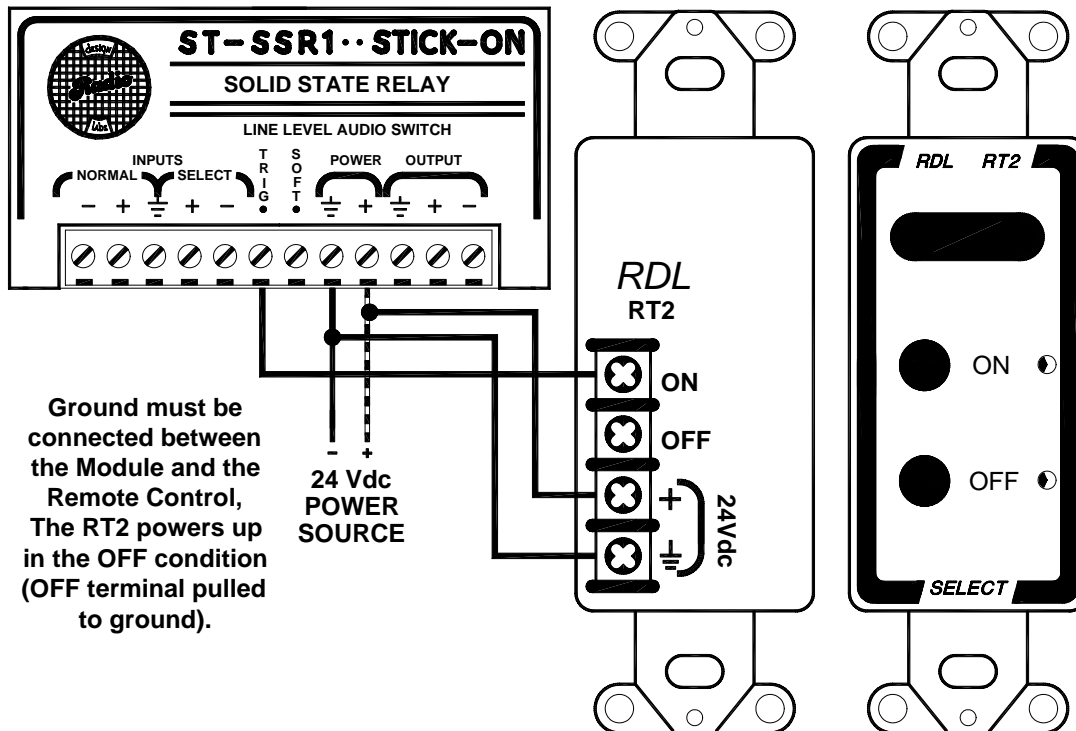

### TYPICAL PERFORMANCE

Selectors:

Indicators:

Connections:

Mounting:

Dimensions:

Power Requirement:

2 Momentary Pushbuttons, 1 for ON, 1 for OFF

2 LEDs, Indicates status ON or OFF

Power input; Separate Open-collector outputs for ON and OFF (25 mA)

Mounts in US standard electrical box, decorative plate available separately

Height: 4 in. (10.4 cm); Depth: 1.6 in. (4.1 cm); Width: 1.3 in. (3.3 cm)

24 to 33 Vdc @ 30 mA, Ground-referenced

Radio Design Labs Technical Support Centers

U.S.A. (800) 933-1780, (928) 778-3554; Fax: (928) 778-3506

Europe [NH Amsterdam] (+31) 20-6238 983; Fax: (+31) 20-6225-287