



**RDL**<sup>®</sup>  
Radio Design Labs

SPECIALISTS IN PRACTICAL PRECISION ENGINEERING™

## FLAT-PAK™ SERIES Model FP-ECC1 Energy Conservation Controller

- Automatic Mains Power On/Off Controller
- Power-Up Triggered by Audio and/or External Switch
- Audio and/or External Input to Hold Power On
- Selectable Power-Down Delay after Input Inactivity
- Line-Level, Speaker-Level or 70/100 V Audio Hold Input
- Adjustable Sensitivity with LED for Audio Sensing Inputs
- Open-Collector and Relay Outputs to Activate System Power
- Pulse Outputs to Initiate Power-Up and Power-Down
- Switch-Selectable Low-Cut Filter for Audio Sensing Inputs
- Directly Controllable by OEM Equipment or RDL Remote Control
- 0 to 10 Vdc VCA Control Output from Optional Remote Control
- Connection to Remote Control Using Twisted-Pair Cable
- Input and Control Output Connections on Detachable Terminal Blocks
- Power LED Indicates Active or Standby Condition

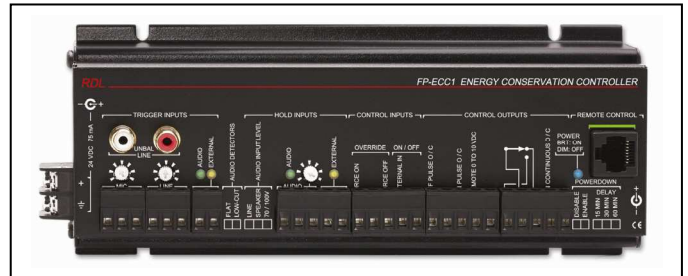

The FP-ECC1 is an energy conservation control module in the convenient line of FLAT-PAK products, featuring the superior engineering and components common to RDL products. The FP-ECC1 may be rack or surface mounted with optional FLAT-PAK series accessories.

The FP-ECC1 is a control unit designed to automatically turn an A/V system on and off for maximum energy savings. Multiple sensing inputs and control outputs are provided in standard formats affording optimum flexibility in a broad variety of installations. The FP-ECC1 features may be enhanced through the use of optional RDL remote controls and detection and control modules. Connections are provided to interface the FP-ECC1 with OEM equipment.

Actuation of any trigger input activates the **CONTROL OUTPUTS**. The open-collector **PULSE ON** output is pulled to ground for one second to initiate startup of OEM equipment requiring momentary actuation. The open-collector **ON CONTINUOUS** terminal is pulled to ground and the relay is engaged to control logic or relay-switched mains outlets for the A/V system. Mains power may not be directly connected through the FP-ECC1. Once triggered, the outputs are held on by any of the **HOLD INPUTS** or **TRIGGER INPUTS**. Loss of signal on the trigger and hold inputs starts the power-down **DELAY** which is switch-selectable for 15, 30 or 60 minutes. If the trigger and hold inputs remain inactive for the delay period, the **ON CONTINUOUS** terminal opens, the relay is de-energized and the **PULSE OFF** output is pulled to ground for one second to initiate shutdown of OEM equipment requiring momentary actuation. The control outputs remain off and the module remains in a standby condition until the next trigger input is received. The front-panel blue power LED glows dimly when the control outputs are off; it is bright when the control outputs are on.

The FP-ECC1 may be triggered by any of the three audio trigger inputs or by pulling the external trigger terminal to ground using RDL detection or control modules, open-collector outputs from OEM controllers or equipment, or by a magnetic door switch or motion sensor. Audio inputs are provided to bridge a balanced microphone and a balanced line-level source. The sensitivity of each of these audio inputs is individually adjustable over the entire range of expected input signal levels. A pair of RCA jacks is provided to trigger on standard unbalanced audio sources. An audio threshold LED is provided for easy gain adjustment of each balanced audio input. A separate LED indicates when the external trigger terminal is active.

Two **HOLD INPUTS** are provided in addition to the **TRIGGER INPUTS** to keep the system powered while there is any user activity. The **AUDIO** input is normally connected to the speaker output of the system power amplifier. The FP-ECC1 accepts 4 or 8 ohm speaker levels, constant-voltage levels or line-levels. Detection sensitivity is adjustable over the entire range of expected input signal levels by observing the front-panel audio threshold LED. An external hold terminal activates the hold mode using RDL detection or control modules, open-collector outputs from OEM controllers or equipment, or other switches such as motion sensors.

Switch-selectable low-cut filters are provided for all of the audio sensing inputs. These filters attenuate low frequencies that could false trigger the module. Audio and control connections use detachable terminal blocks.

RDL offers optional remote controls that connect directly to the FP-ECC1 using twisted-pair wire and RJ45 connectors. The remote controls provide the end-user with a momentary pushbutton to manually trigger the module control outputs and manually return the module to the standby condition. A switch on the FP-ECC1 enables or disables a remote control feature to lock the FP-ECC1 control outputs in the off condition by pressing the remote power button for three seconds. An LED display on the remote control glows yellow when the module is in standby awaiting a trigger and glows blue when the system is active. If the FP-ECC1 is locked in the off condition, the display glows red. A remote control is available that provides both a momentary power button and a volume control. When connected, the remote volume control adjusts the 0 to 10 Vdc output on the FP-ECC1 for controlling RDL VCA modules and amplifiers or other OEM equipment. An **ON/OFF** external control input terminal, momentarily pulled to ground, alternately toggles the FP-ECC1 between the standby and on conditions for control by OEM equipment.

Emergency paging may require the system controlled by the FP-ECC1 to be forced either on or off. Override terminals **FORCE ON** and **FORCE OFF** are provided for either condition and supersede all other inputs or operating states.

The FP-ECC1 is powered by 24 Vdc and consumes less than 25 mA when it is in the standby condition awaiting a trigger input.



## FLAT-PAK™ SERIES Model FP-ECC1 Energy Conservation Controller

## Installation/Operation



EN55103-1 E1-E5; EN55103-2 E1-E4  
Typical Performance reflects product at publication time exclusive of EMC data, if any, supplied with product. Specifications are subject to change without notice.

### Trigger Input Connections

With only one audio input connected from an audio source at the desired trigger level, adjust the corresponding MIC or LINE sensitivity control until the AUDIO LED just illuminates. The EXTERNAL LED illuminates when the module receives a switched trigger input.

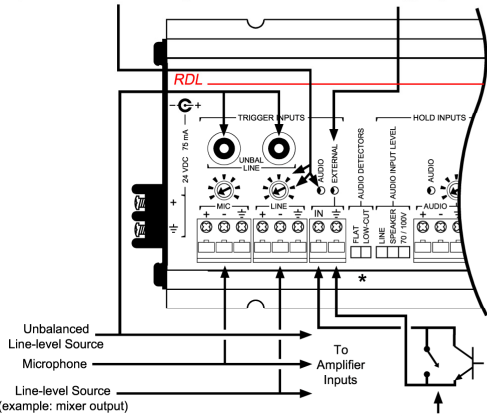

Connect one, two or three audio sources to trigger the CONTROL OUTPUTS that turn on the AV system power mains. Note: A switched trigger may be connected in addition to the audio trigger(s). Any trigger will activate the CONTROL OUTPUTS.

Connect a switch or an open-collector from the IN terminal to ground to trigger the module. Trigger examples include OEM open-collector outputs, magnetic switches, motion sensors and the control outputs of RDL sensing modules.

### AUDIO INPUT WIRING

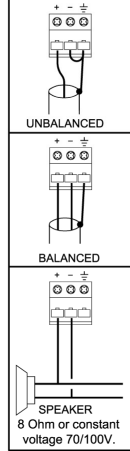

### Hold Input Connections

Adjust the sensitivity control until the AUDIO LED just illuminates with the lowest expected audio signal level that must keep the system turned on.

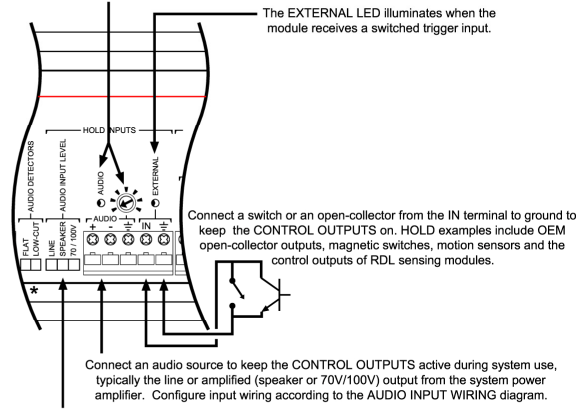

Set the switch for the audio input type connected to the hold input. Set to LINE for line-level signals. Set to SPEAKER for 4 or 8 Ohm amplifier outputs up to 500 W or for 25 V constant voltage amplifier outputs. Do NOT set to 70/100V for 70 or 100 V constant voltage amplifier outputs or for 4 or 8 ohm amplifier outputs > 500 W. SET TO SET THE SWITCH TO LINE WITH AN AMPLIFIER OUTPUT CONNECTED TO THE AUDIO HOLD INPUT.

\* If hum is possible from the audio trigger or hold input sources, set the AUDIO DETECTORS filter switch to LOW-CUT. If hum is not anticipated, set the filter switch to the FLAT position.

### Control Output Connections

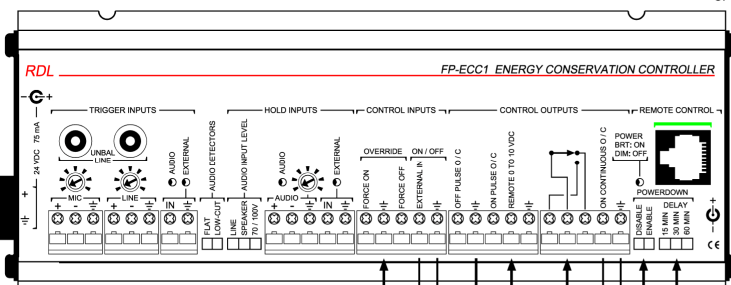

Ground the FORCE ON terminal using a switch or open-collector to override all FP-ECC1 functions and force the CONTROL OUTPUTS on. Ground the FORCE OFF terminal using a switch or open-collector to override all FP-ECC1 functions and force the CONTROL OUTPUTS off. Release the terminals to resume normal operation.

If OEM equipment or an external momentary control is needed to toggle the FP-ECC1 between ON (CONTROL OUTPUTS active) and STANDBY (waiting for an input trigger to activate the CONTROL OUTPUTS), connect an open-collector or momentary switch to the EXTERNAL ON/OFF terminals.

If OEM equipment requires a momentary pull-to-ground pulse to initiate power-up and power-down, connect the ON PULSE and OFF PULSE terminals to the control terminals of the OEM equipment.

Use relay contacts to switch devices not controlled by open collectors. **SEE WARNING!** Connect 0 to 10 V output to the input of an RDL or OEM VCA. Note: This output is only active if an optional D-ECR1L type remote control is connected.

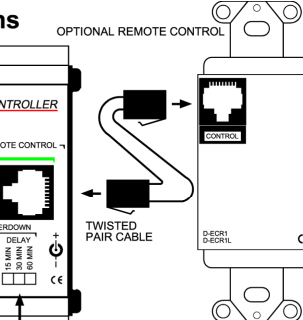

Set the DELAY timer to the desired length of time the system should stay on after a loss of trigger and hold signals.

If a remote control is connected, the user may hold the power button on the remote control for 3 seconds to shut the system off and disable the FP-ECC1 from automatically sensing a trigger input; the CONTROL OUTPUTS will remain off until the user enables the FP-ECC1 (the FP-ECC1 is activated). To prevent the remote control from disabling the automatic power-up trigger inputs, set the switch to DISABLE.

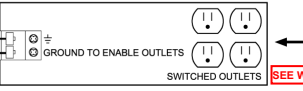

### OPTIONAL REMOTE CONTROL

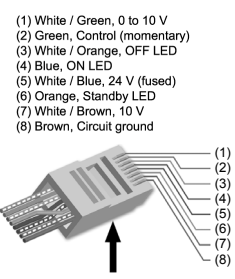

- (1) White / Green, 0 to 10 V
- (2) Green, Control (momentary)
- (3) White / Orange, OFF LED
- (4) Blue, ON LED
- (5) White / Blue, 24 V (fused)
- (6) Orange, Standby LED
- (7) White / Brown, 10 V
- (8) Brown, Circuit ground

Tab on bottom of connector

**WARNING: Relay contacts and open-collector output are for low-voltage signal control of the mains outlet. DO NOT CONNECT MAINS POWER DIRECTLY TO THE FP-ECC1.**

CONNECT AV SYSTEM AND/OR AUDIO POWER AMPLIFIER TO THE SWITCHED OUTLET. **SEE WARNING!**

### TYPICAL PERFORMANCE

- Audio Trigger Inputs (3):
- Audio Trigger Threshold:
- Switched Trigger Input:
- Audio Hold Input:
- Audio Hold Threshold:
- Switched Hold Input:
- Audio Detection Bandwidth:
- Audio Low-Cut Filters:
- Control Outputs, Continuous for Mains Switching (2):
- Control Outputs, Momentary (2):
- Open-collector external pull-up voltage:
- Control Input:
- Override inputs (2):
- Control Outputs Turn-off Delay:
- Remote Control:
- Remote Control Trigger Disable:
- VCA Output:
- Indicators (5):

Power Connections (3):  
Power Requirement:  
Overall Dimensions:

- Balanced Mic (50 kΩ bridging), Balanced Line (50 kΩ bridging), Unbalanced Line (50 kΩ)
- Mic: -70 to -38 dBu, adjustable; Line: -38 to -12 dBu, adjustable; Unbalanced Line: -35 dBV
- Pull-to-ground, 0.1 mA pullup to 5 Vdc, 2.5 Vdc threshold
- Switch-selectable Line-level, Speaker-level or Constant voltage
- Line: -35 to 0 dBu, adjustable; Speaker: 1 mW to 3 W (8Ω), 90 mV to 5 V adjustable; 70/100 V: 600 mV to 38 V
- Pull-to-ground, 0.1 mA pullup to 5 Vdc, 2.5 Vdc threshold
- 20 Hz to 5 kHz
- Switch-selectable -20 dB @ 50 Hz (reference 1 kHz)
- SPDT Relay, Open-collector @ 50 mA
- Off Pulse: Open-collector @ 25 mA for 1 second; On Pulse: Open-collector @ 25 mA for 1 second
- 24 Vdc maximum
- Pull-to-ground, 0.1 mA pullup to 5 Vdc, 2.5 Vdc threshold (toggles between standby and control outputs active)
- Force on, force off (overrides all other functions to force control outputs on or off)
- Switch-selectable 15, 30 or 60 minutes following loss of trigger and hold inputs
- RJ45 for optional dedicated RDL remote controls (example: D/DS-ECR1, D/DS-ECR1L)
- Switch-selectable to enable or disable a remote control from powering down and disabling the trigger inputs 0 to 10 Vdc (set by optional remote control)
- Audio trigger LED (green); External switched trigger LED (yellow); Audio hold LED (green);
- External switched hold LED (yellow); Power, Bright = Control Outputs active, Dim = Control Outputs inactive
- Terminal block; dc power jack (2)
- 24 Vdc @ 75 mA, 25 mA idle current
- Height: 1.42 in. 3.61 cm, Width: 3.25 in. 8.26 cm, Length: 8.5 in. 21.6 cm

NOTE: This equipment has been tested and found to comply with the limits for a Class B digital device, pursuant to part 15 of the FCC Rule. These limits are designed to provide reasonable protection against harmful interference in a residential installation. The equipment generates, uses and can radiate radio frequency energy and, if not installed and used in accordance with the instructions, may cause harmful interference to radio communications. However, there is no guarantee that interference will not occur in a particular installation. If this equipment does cause harmful interference to radio or television reception, which can be determined by turning the equipment off on, the user is encouraged to try to correct the interference by one or more of the following measures:

- Reorient or relocate the receiving antenna
- Increase the separation between the equipment and receiver
- Connect the equipment into an outlet on a circuit different from that which the receiver is connected.
- Consult the dealer or an experienced radio/TV technician for help.