



RDL[®]
Radio Design Labs

SPECIALISTS IN PRACTICAL PRECISION ENGINEERING™

max **RACK-UP**[®] SERIES

Model RU-SQ6A Sequencing Controller

ANYWHERE YOU NEED...

- Control of Sequential Power-Up or Events
- Adjustable Up/Down Time Interval
- Relay and Open-Collector Outputs
- Front-panel or Remote Activation
- Up to SIX Sequential Events
- **SURE-LOK**[™] Output Supervision

You Need The RU-SQ6A!



The RU-SQ6A is part of the group of versatile RACK-UP products from Radio Design Labs. RACK-UPs feature the advanced circuitry for which RDL products are known, combined with accessible, user-friendly controls and displays. The ultra-compact design permits high-density installations, with *three* products mounted in a single rack unit! Single RACK-UPs can be mounted right where they are needed using the adhesive methods popularized by RDL's STICK-ON[®] series of products. Optional brackets permit mounting a RACK-UP module above, below, or in front of any flat surface. Optional rack-mount adapters and chassis are available for conventional RACK-UP series installation.

APPLICATION: The RU-SQ6A is the ideal choice in installations where sequential **ON** and sequential **OFF** functions are desired. Control and output connections are made on the rear panel through clearly identified detachable terminal blocks.

Two types of outputs are provided for each of the 6 sequential steps. One type is an open collector capable of switching loads of 50mA. The other type is an SPST dry contact closure which may be used to control a variety of equipment. A single-turn front-panel **TIMING INTERVAL** control adjusts the time delay between channels from 1 to 10 seconds. Front-panel LEDs show when each output channel turns on and off. An internal microcontroller insures reliable, accurate timing.

The up or down sequence is user-controlled by a front-panel pushbutton switch unless the module is set for remote operation. A rear-panel switch set by the installer selects either front-panel or remote control activation. LEDs indicate whether the front-panel **SEQUENCE CONTROL** switch or the remote terminals are active. Grounding the rear-panel **ACTIVATE** terminals or turning on the front-panel **SEQUENCE CONTROL** switch causes an **UP REQUEST** that starts the RU-SQ6A outputs to turn on sequentially. The outputs remain active until the **UP REQUEST** is cancelled by turning off the front-panel or remote control switch, causing the outputs to turn off in reverse sequence. If the **ACTIVATE** terminal is permanently grounded with the module set for remote control, the RU-SQ6A outputs will turn on sequentially when power is applied to the module; all outputs will turn off simultaneously when power is removed from the RU-SQ6A. The **UP REQUEST** LED is illuminated when an **UP** sequence is requested. When the sequence is complete, the **COMPLETE** LED indicates the **SURE-LOK**[™] supervisory circuit is actively latching the outputs active until the user deactivates the sequence.

Wherever sequential up and down switching is needed the RU-SQ6A is the ideal choice. Use the RU-SQ6A individually, or combine it with other RDL RACK-UP or STICK-ON products as part of a complete audio/video system.



RDL[®]
Radio Design Labs

SPECIALISTS IN PRACTICAL PRECISION ENGINEERING™



max RACK-UP[®] SERIES

Model RU-SQ6A Sequencing Controller

Installation/Operation



EN55103-1 E1-E5; EN55103-2 E1-E4
Typical Performance reflects product at publication time exclusive of EMC data, if any, supplied with product. Specifications are subject to change without notice.

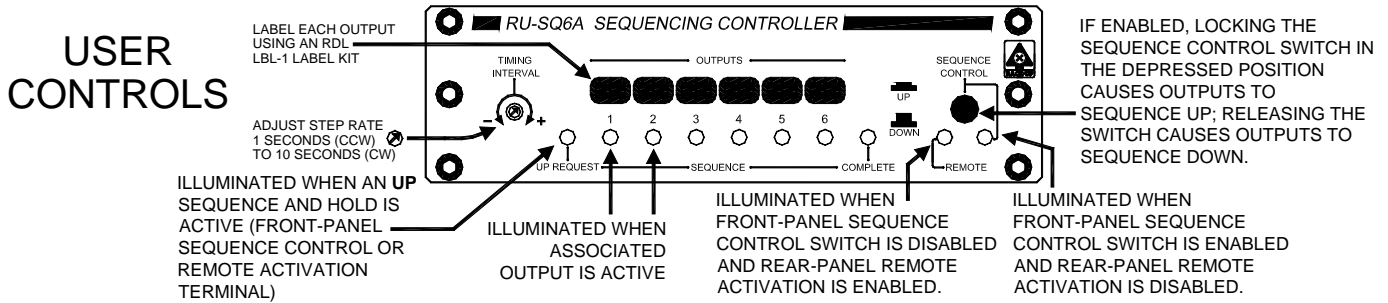
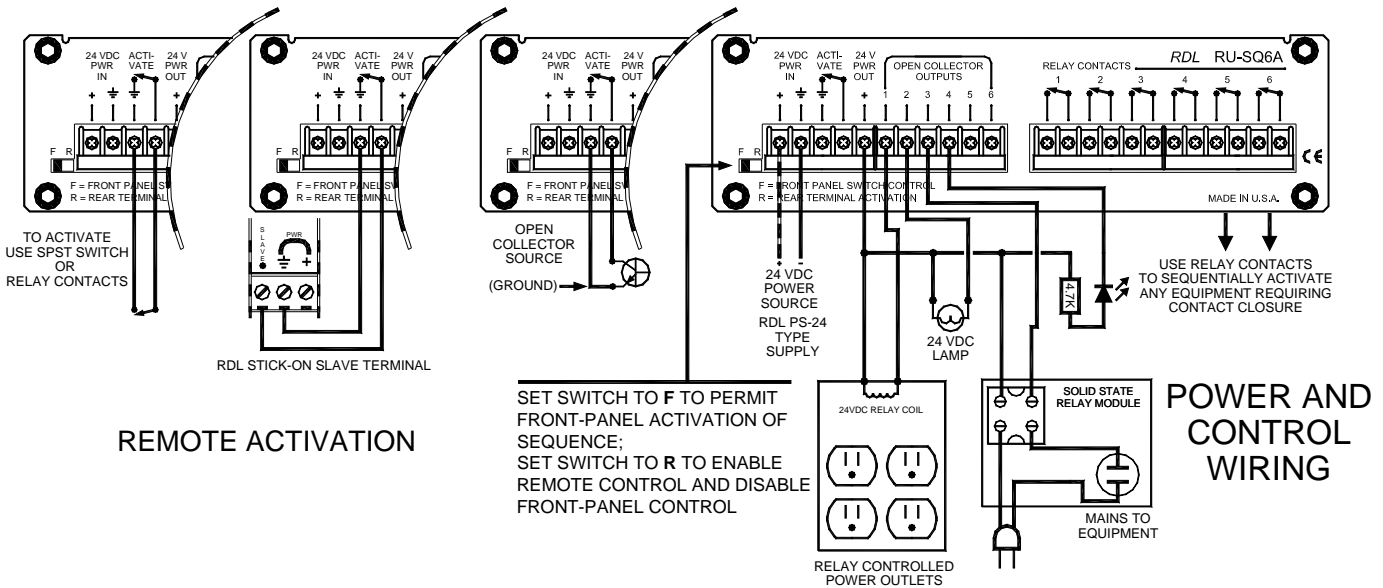

TYPICAL PERFORMANCE

Control Input:
Interval Between Outputs:
Indicators (10):

24 Vdc Output:
Open Collector (6):
Relay Outputs (6):

Maximum Switching Power:
Maximum Switching Voltage:
Maximum Switching Current:
Maximum Carrying Current:

Power Requirement:

Dimensions:

External closure < 2.5 mA @ 24 Vdc
1 to 10 seconds nominal, front-panel adjustable
Red LEDs indicating channel 'on' condition (6)
Green LED indicating UP REQUEST
Green LED indicating sequence COMPLETE
Red / Green LEDs indicating Remote or Front-Panel Activation
1.1 A maximum, 75 mA less than power supply current
200 mA surge; 50 mA continuous; 200 mA maximum
SPST (closed when active)
60 W, 125 VA
220 Vdc, 250 Vac
2 A
3 A
24 to 33 Vdc @ 100 mA
plus total load current connected to 24 Vdc output, Ground-referenced
Height: 1.7 in. 4.3 cm
Length: 5.8 in. 15.0 cm
Depth: 3.45 in. 8.8 cm

NOTE: This equipment has been tested and found to comply with the limits for a Class B digital device, pursuant to part 15 of the FCC Rule. These limits are designed to provide reasonable protection against harmful interference in a residential installation. The equipment generates, uses and can radiate radio frequency energy and, if not installed and used in accordance with the instructions, may cause harmful interference to radio communications. However, there is no guarantee that interference will not occur in a particular installation. If this equipment does cause harmful interference to radio or television reception, which can be determined by turning the equipment off an on, the user is encouraged to try to correct the interference by one or more of the following measures:

- Reorient or relocate the receiving antenna and receiver
- Increase the separation between the equipment and receiver
- Connect the equipment into an outlet on a circuit different from that which the receiver is connected.
- Consult the dealer or an experienced radio/TV technician for help.

Radio Design Labs Technical Support Centers
U.S.A. (800) 933-1780, (928) 778-3554; Fax: (928) 778-3506
Europe [NH Amsterdam] (+31) 20-6238 983; Fax: (+31) 20-6225-287