

RCX™ ROOM COMBINING SYSTEM

Version 3.4

Table of Contents

1. System Overview.....	2
2. Quick-Start / System Operation.....	4
2.1 System Setup Guide.....	4
2.2 Equipment Planning and Wiring Guide.....	5
2.3 System Operation.....	6
3. System Setup.....	7
3.1 Configuration Overview.....	7
3.2 Instructions for Selecting Room Configuration.....	8
Room Layout Diagrams.....	9
3.3 Instructions for Setting Power Amplifier Levels.....	11
3.4 Instructions for Storing Preset Levels.....	12
3.5 Instructions for Tandem Configuration Setup.....	13
4. Equipment Planning and Wiring.....	15
4.1 Equipment Mounting and Prewiring Requirements.....	15
4.1.1 Common Equipment Locations/System Controller.....	15
4.1.2 Room Audio Inputs.....	15
4.1.3 Room Audio Control (Level and Source).....	15
4.1.4 Room Audio Control (Level only).....	16
4.1.5 Multiple Room Audio Controls.....	16
4.1.6 Room Combination Control Panels.....	16
4.1.7 Linking Two Groups of Rooms (Two Controllers).....	17
4.1.8 Music Source.....	17
4.1.9 Paging Source and Control.....	17
4.1.10 Open Collector Status Outputs.....	17
4.1.11 Control Inputs.....	17
4.1.12 Audio Recording Outputs.....	17
4.2 Equipment Wiring.....	18
4.2.1 Room Audio Input Wiring.....	18
4.2.2 Audio Output Wiring.....	20
4.2.3 Room Control Wiring.....	21
4.2.4 Background Music Input Wiring.....	23
4.2.5 Paging Input Wiring.....	23
4.2.6 Connecting Auxiliary Controls and Products.....	24
4.2.7 RCX-CD1 Custom Control Panel.....	25
5. Typical Performance.....	26
6. Mounting Dimensions.....	27

Radio Design Labs Technical Support Centers

U.S.A. (800) 933-1780, (928) 778-3554; Fax: (928) 778-3506

Europe [NH Amsterdam] (+31) 20-6238 983; Fax: (+31) 20-6225-287

RDL • 659 6th St. • Prescott, AZ, USA 86301 • (928) 443-9391 • FAX (928) 443-9392 • <http://rdlnet.com>

1. RCX System Overview

The RCX system is an engineered room combining system configured from a variety of related products. Each system requires an RCX-5C* Controller plus an RCX Room Control for each room. A maximum of two RCX Room Controls may be installed in each room. The Controller may be remote controlled using one or more customized RCX-CD1 Control/Display Panels.

RCX-5C Controller: The system controller accommodates a maximum of 5 rooms, combined in any adjacent arrangement. Audio inputs from each room are: LINE (only), MIC+LINE (dynamic mic), MIC+LINE (condenser mic). A front-panel level knob with LED metering is provided for each room input. MUSIC and PAGING inputs may feed each room if desired. Two RCX-5Cs may be linked in larger systems where two groups of rooms need to be combined. The standard RCX-5C does not mute mics in a room while listening to music.

RCX-5CM Controller: The RCX-5CM is an RCX-5C that mutes the mics in a room while listening to background music.

RCX-CD1 Control and Display Panel: This optional remote control panel is customized by RDL with room layout graphics matching each installation. Room combination status information and selection is provided on the panel. Multiple panels may be connected to the RCX-5C controller. The RCX-CD1 may be ordered with key lock protection (RCX-CD1L). The RCX-CD1(L) mounts in an equipment rack (19", 4RU) or on a wall using the optional RDL RCX-BZL wall mount bezel.

RCX-CD1L Control and Display Panel: The RCX-CD1L is an RCX-CD1 with a keylock to prevent selecting room combinations. The room combination display operates with the keylock is in either the **LOCKED** or **UNLOCKED** position.

D-SERIES Wall Panels and Controls (Compatible with Decora® plates and accessories)

Note: All D-SERIES panels and controls described below are available in different colors, indicated by the product prefix. The standard "D-" prefix applies to the standard model: White steel panel with gray graphics on a white polycarbonate background. A "DS-" prefix applies to the stainless steel model: Stainless steel panel with black graphics on a stainless steel background. A "DB-" prefix applies to the black model: Black steel panel with white graphics on a black polycarbonate background. For example, a D-RCX1 is the white model; a DS-RCX1 is the stainless steel model; a DB-RCX1 is the black model. The "D-" prefix will be used to describe these products throughout this manual.

D-RCX1 Room Control: The standard RCX remote control features pushbutton UP/DOWN volume adjustment, and pushbutton selection between MUSIC and LOCAL (microphones and/or line level inputs). The D-RCX1 mounts in an RDL WB-1U wall box.

D-RCX2 Room Control: Pushbutton selection between MUSIC and LOCAL (microphones and/or line level inputs) is beneath a rotary optical encoder knob with an LED virtual pointer. The knob controls the audio volume. The D-RCX2 mounts in an RDL WB-1U wall box.

D-RCX10R Room Control: This control provides level adjustment identical to the D-RCX2 except without source selection. The D-RCX10R is suited to systems in which rotary control is preferred and that do not use the background music source. It may also be used as a second (volume only) Room Control in a system that uses background music. The D-RCX10R mounts in an RDL WB-1U wall box.

*Notes: **RCX-5C:** When the MUSIC source is selected on a D-RCX1 or D-RCX2, the system background music is switched on and the local inputs remain active, permitting users to make announcements over the music without selecting LOCAL on the wall control. When LOCAL is selected, the background music is disabled in the room.*

***RCX-5CM:** When the MUSIC source is selected on a D-RCX1 or D-RCX2, the system background music is switched on and the local inputs are muted. When LOCAL is selected, the background music is disabled in the room.*

D-J1 Microphone Input Panel: This input panel provides a microphone input (XLR).

D-J2 Line Input Panel: This input panel installs in a room to provide a stereo unbalanced line level input (phono jacks). The line inputs are passively mixed to mono and transformer balanced.

D-J3 Microphone + Line Input Panel: This input panel installs in a room to provide both a microphone input (XLR) and a stereo unbalanced line level input (phono jacks). The line inputs are passively mixed to mono and transformer balanced.

D-A2 Audio Output Panel: This output panel provides two -10 dBV (left and right) outputs from the room audio signal. The D-A2 is mounted in a room to allow users to record the audio in that room. The output signals are transformer isolated from the room amplifier feed.

Note: The D-J1, D-J2, D-J3 and D-A2 mount in RDL WB-1U wall boxes.

ULTRASTYLE Wall Panels and Controls

RCX-1 Room Control: The standard RCX remote control features pushbutton UP/DOWN volume adjustment, and pushbutton selection between MUSIC and LOCAL (microphones and/or line level inputs). The RCX-1 mounts in an RDL WB-2U wall box.

RCX-2 Room Control: Pushbutton selection between MUSIC and LOCAL (microphones and/or line level inputs) is adjacent to a large rotary optical encoder knob with an LED virtual pointer. The knob controls the audio volume. The RCX-2 mounts in an RDL WB-2U wall box.

RCX-10R Room Control: This control provides level adjustment identical to the RCX-2 except without source selection. The RCX-10R is suited to systems in which rotary control is preferred and that do not use the background music source. It may also be used as a second (volume only) Room Control in a system that uses background music. The RCX10R mounts in an RDL WB-1U wall box.

RCX-3/3S Room Controls: These remote controls provide the same features as the RCX1, but require a key to activate source selection or volume adjustment. The absence of buttons or knobs make them ideally suited to institutional use. The RCX-3 features ULTRASTYLE design; the RCX-3S is finished in stainless steel with gray trim. Either model mounts in an RDL WB-2U wall box.

RCX-3R/3RS Room Controls: These remote controls provide up/down key operated volume control for systems that do not use a background music source. The RCX-3R features ULTRASTYLE design; the RCX-3RS is finished in stainless steel with gray trim. Either model mounts in an RDL WB-2U wall box.

*Notes: **RCX-5C:** When the MUSIC source is selected on an RCX-1, RCX-2 or RCX-3, the system background music is switched on and the local inputs remain active, permitting users to make announcements over the music without selecting LOCAL on the wall control. When LOCAL is selected, the background music is disabled in the room.*

***RCX-5CM:** When the MUSIC source is selected on an RCX-1, RCX-2 or RCX-3, the system background music is switched on and the local inputs are muted. When LOCAL is selected, the background music is disabled in the room.*

RCX-J1 Microphone Input Panel: This input panel provides a microphone input (XLR).

RCX-J2 Line Input Panel: This input panel installs in a room to provide a stereo unbalanced line level input (phono jacks). The line inputs are passively mixed to mono and transformer balanced.

RCX-J3 Microphone + Line Input Panel: This input panel installs in a room to provide both a microphone input (XLR) and a stereo unbalanced line level input (phono jacks). The line inputs are passively mixed to mono and transformer balanced.

RCX-A2 Audio Output Panel: This output panel provides two -10 dBV (left and right) outputs from the room audio signal. The RCX-A2 is mounted in a room to allow users to record the audio in that room. The output signals are transformer isolated from the room amplifier feed.

Note: The RCX-J1, J2, J3 and A2 mount in RDL WB-1U wall boxes.

*Unless otherwise stated, references to the RCX-5C apply to all current RCX-5C models.

Note: The D-SERIES and/or ULTRASTYLE wall panels and controls may be used interchangeably within the same RCX system.

2. QUICK-START / SYSTEM OPERATION

2.1 System Setup Guide

The QUICK-START System Setup Guide is intended to familiarize new users with system setup. It is also intended as a functional installation guide and checklist for installers who have previously connected and set up an RCX system. The complete RCX instructions in Sections 3 and 4 should be read, understood and followed for first time installations.

SELECT ROOM CONFIGURATION

- 1] Hold Button 1 in while powering up the RCX-5C. LED 1 flashes during setup.
- 2] Find room layout (Section 3.2). Set rear-panel **MODE** switch and buttons as shown.
- 3] *Only* if 'continuous' remote inputs are used, set Button **ALL** LED to *on*.

(Default inputs are 'momentary' as required if RCX-CD1 is connected to RCX-5C)

- 4] Push Button 1 to save settings, exit Room Configuration Setup and assume normal operation.

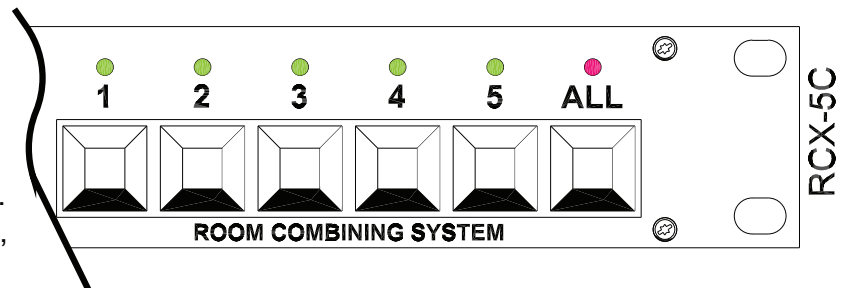

SET POWER AMPLIFIER LEVELS

- 1] Turn power amplifier gain *off* for room being adjusted.
- 2] On RCX Room Control, select **LOCAL** and ramp level to maximum.
- 3] Connect a typical source (usually mic) providing usual audio level.
- 4] Use front-panel dual-LED meter to set corresponding level knob.
- 5] Adjust power amplifier gain for the maximum level ever desired.
- 6] Ramp level *off* and repeat for all other rooms.

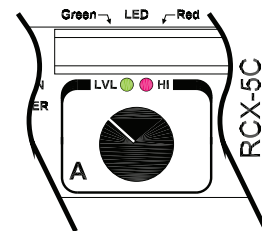

STORING PRESET LEVELS

Note: Default preset levels are 18 dB below max.; storing new levels is optional.

- 1] Set all room levels *off* by repowering RCX-5C with the rear-panel **PRESET** button held in.
- 2] Turn level up to desired level (on only **one** RCX room control at a time).
- 3] Push **PRESET** button; LED will illuminate *steady* for 3 seconds. *(If more than one room is turned up (not off), LED flashes indicating error.)*
- 4] Ramp level to *off* position (red LED *on*) and repeat steps 1-3 for other rooms.
- 5] If MUSIC is used, repeat steps 1-4, but set RCX Room Controls for MUSIC source.

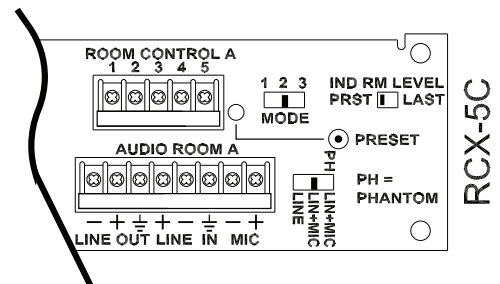

SET UNCOMBINED ROOMS TO USE EITHER THE PRESET OR LAST LEVEL USED

- 1] Set the **IND RM LEVEL** rear panel switch to **PRST** if the preset level is desired upon selecting the **LOCAL** source in any uncombined room; or
- 2] Set the **IND RM LEVEL** switch to **LAST** to return to the last local level setting upon selecting **LOCAL**.

TANDEM LEVEL CONTROL AND/OR SOURCE SELECTION

*Note: Room level control and source selection initially default to TANDEM; storing other modes is optional. (TANDEM control causes the RCX Room Control(s) in a combined room to control the level and/or source selection in all associated combined rooms. When MUSIC LOCKOUT source selection mode is active, the controller will force all Room Controls to the LOCAL source when the associated room is combined. If any room in the system is equipped **only** with Room Controls that do not provide source selection [RCX-10R, D-RCX10R, RCX-3R, RCX-3RS], then the MUSIC LOCKOUT mode **must** be programmed.)*

- 1] Repower RCX-5C with Button **ALL** held in. LED **ALL** flashes during setup.
- 2] Set Button 1 LED *on* for TANDEM volume control (factory default); *off* for INDEPENDENT
- 3] Set Button 2 LED *on* for TANDEM source select (factory default); *off* for MUSIC LOCKOUT
- 4] Push Button **ALL** to save settings, exit Tandem Configuration Setup and resume operation.

2.2 Equipment Planning and Wiring Guide

Minimum rectangular
clearance inside box

MOUNTING REQUIREMENTS

Width Height

RCX-A2 or D-A2	Use RDL WB-1U (US/International) or US single electrical box*	1.80" (4.60 cm) x 2.73" (6.93 cm)
RCX-J1 or D-J1	Use RDL WB-1U (US/International) or US single electrical box*	1.80" (4.60 cm) x 2.73" (6.93 cm)
RCX-J2 or D-J2	Use RDL WB-1U (US/International) or US single electrical box*	1.80" (4.60 cm) x 2.73" (6.93 cm)
RCX-J3 or D-J3	Use RDL WB-1U (US/International) or US single electrical box*	1.80" (4.60 cm) x 2.73" (6.93 cm)
D-RCX1	Use RDL WB-1U (US/International) or US single electrical box*	1.80" (4.60 cm) x 2.73" (6.93 cm)
D-RCX2	Use RDL WB-1U (US/International) or US single electrical box*	1.80" (4.60 cm) x 2.73" (6.93 cm)
RCX-1	Use RDL WB-2U (US/International) or US double electrical box**	3.55" (9.02 cm) x 2.73" (6.93 cm)
RCX-2	Use RDL WB-2U (US/International) or US double electrical box**	3.55" (9.02 cm) x 2.73" (6.93 cm)
RCX-3	Use RDL WB-2U (US/International) or US double electrical box**	3.55" (9.02 cm) x 2.73" (6.93 cm)
RCX-10R or D-RCX10R	Use RDL WB-1U (US/International) or US single electrical box*	1.95" (4.95 cm) x 2.73" (6.93 cm)
RCX-5C	Rackmounted (19"), 1RU, leave ventilation above and below	
RCX-CD1 or RCX-CD1L	Rackmounted (19"), 4RU; Wallmounted using RDL RCX-BZL	

* Note that US single gang masonry boxes are a substandard width not suitable for these products.

**If US "square" electrical box is installed with a mud ring, use the RDL MR-2 (available separately) in place of any mud ring that does not provide the minimum required rectangular clearance.

(Note: Products with "D" prefix finish with standard OEM or RDL Decora® plates.)

WIRING REQUIREMENTS

RCX-5C or RCX-5CM	Audio inputs and outputs use standard single shielded pair Interconnect with other RCX components using wires listed below:
RCX-A2 or D-A2	Single shielded pair audio wire (normally 24 gauge / 0.22 mm ² or heavier)
RCX-J1 or D-J1	Single shielded pair audio wire (normally 24 gauge / 0.22 mm ² or heavier)
RCX-J2 or D-J2	Single shielded pair audio wire (normally 24 gauge / 0.22 mm ² or heavier)
RCX-J3 or D-J3	Two shielded pairs audio wire (normally 24 gauge / 0.22 mm ² or heavier)
RCX-1 or D-RCX1	5 conductors, or two shielded pairs (normally 24 gauge** / 0.22 mm ² or heavier)
RCX-2 or D-RCX2	5 conductors, or two shielded pairs (normally 24 gauge** / 0.22 mm ² or heavier)
RCX-3	5 conductors, or two shielded pairs (normally 24 gauge** / 0.22 mm ² or heavier)
RCX-10R or D-RCX10R	4 conductors (normally 24 gauge** / 0.22 mm ² or heavier)
RCX-CD1 or RCX-CD1L	15 conductors (normally 24 gauge** / 0.22 mm ² or heavier)

** For wire lengths 100 m (330 ft) to 300 m (1000 ft), 20 gauge / 0.5 mm² (min.) wire is required.
For wire lengths 300 m (1000 ft) to 600 m (2000 ft), 18 gauge / 1.0 mm² (min.) wire is required.

Notes:

1] A maximum of two Room Controls (RCX-1 or D-RCX1, RCX-2 or D-RCX2, RCX-3, RCX-10R or D-RCX10R) may be installed in each room by continuing the wiring run from the first remote to the second remote, or by making a 'home run' from each Room Control back to the RCX-5C.

2] Multiple RCX-CD1 panels may be connected to a single RCX-5C by continuing the wiring run from the first RCX-CD1 to subsequent RCX-CD1s, or by making a 'home run' from each RCX-CD1 back to the RCX-5C.

WIRING DETAILS

Audio wiring follows industry standards for balanced and unbalanced wiring. Unbalanced inputs require that the "-" input terminal be connected to ground. Unbalanced outputs are connected between "+" and ground; no connection to "-".

RCX Room Controls wire directly to the corresponding numbered terminal on the rear of the controller: 1 to 1, 2 to 2, 3 to 3, 4 to 4, 5 to 5, 6 to 6.

Use a standard stereo RCA patchcord to link two RCX-5C controllers together.

2.3 System Operation

AUDIO INPUT LEVEL ADJUSTMENT

There are 5 audio input level knobs on the RCX-5C front panel. Above each knob is a corresponding RDL dual-LED VU meter. When audio from a room is present, the green LED should pulse brightly with the red LED flashing only occasionally. When mics (or other sources) are set up in a room for a sound check, adjust the corresponding RCX-5C front panel input knob for the correct level on the dual-LED VU meter.

COMBINING AND UNCOMBINING ROOMS

There are 6 pushbuttons on the front panel of the RCX-5C. Five buttons correspond to walls that may divide an area into separate rooms. When a wall is open, adjacent rooms are combined to form a single room. Push the button that corresponds to the open wall to combine the audio in the adjacent rooms. The green LED above the button glows when the adjacent rooms are combined. Pressing the button again will uncombine the rooms.

WHAT HAPPENS WHEN ROOMS ARE COMBINED

When rooms are combined, the audio jack(s) in each combined room are mixed together, and the combined audio feeds the speaker amplifiers in each of the combined rooms. When a room combination button is pushed, the audio level in each of the affected rooms is automatically set to a 'preset' level determined by the installer if the RCX-5C is in the TANDEM level mode. If the factory defaults were not changed during initial setup, the controls in each combined room operate in tandem. If the RCX-5C is in the INDEPENDENT level mode, entering a combination sets each room to **LOCAL** and selects either the preset or last local level used, depending on the position of the rear panel **IND RM LEVEL** switch. Source selection or volume adjustment is possible from any control in the combined room. (The installer may set up the system to leave the volume adjustment independent in each room, or to lock out the **MUSIC** source from being selected when rooms are combined.)

COMBINING ALL ROOMS

Pushing Button **ALL** causes all active rooms in the system to be combined and all Room Controls to be set to the **LOCAL** source. It also causes all audio levels to be set to the levels described in preceding section. All (microphone and/or line level) audio inputs in the rooms will be heard in all rooms. If the RCX-5C is linked to another RCX-5C, the audio in all rooms on both controllers is sent to the speaker amplifiers associated with both controllers when **ALL** combine is selected on *both* controllers.

VISUAL CONTROL PANEL

If the system installation includes an RCX-CD1, adjacent rooms may be combined or uncombined according to a button placed on a graphic view of the room layout. Each combine button on the RCX-CD1 is located in a 'wall', and each such button corresponds to a front-panel button on the RCX-5C controller. Pushing a button shown in a 'wall' combines the adjacent rooms and turns on its associated green LED. Pushing the button again deselects the combination. The RCX-5C front-panel buttons remain active with an RCX-CD1 connected. The RCX-CD1 also provides an **ALL** combine button with LED, and may be equipped with a key lock (RCX-CD1L) to enable/disable the buttons.

ERROR INDICATION

Rooms must be combined with adjacent rooms to form a single larger room. If two separate pairs of rooms have been combined, pushing a button between the two groups results in an error. An error is indicated by rapid flashing of the red LED above the **ALL** combine button.

PAGING

Activate the installer-provided switch to page into all rooms. Paging interrupts all other audio and overrides the individual levels set in each room. Two seconds after the paging switch is released, all audio returns to the previous sources and levels.

3. System Setup

3.1 CONFIGURATION OVERVIEW

As shipped from the factory, the controller is configured as a 2 Room System with momentary REMOTE control inputs, tandem 'combined room' volume controls, tandem 'combined room' source selection and 'preset' stored levels set midscale. If this is your system, you may skip the configuration section.

3.1.1 Required:

If your system has more than two rooms, it must be configured prior to operation. This may be done with the controller installed in the rack, or more easily on the bench prior to installation. The configuration is permanently stored. Once saved, this setup does not need to be repeated. If there is a future change in the room layout (such as a renovation to add a new room), the controller may be reconfigured (5 rooms max.).

Configuration is simple and straightforward. Only four parameters must be selected. If the factory default is set to the desired parameter, then no action is required by the installer.

1] Select Configuration of Rooms

Number and Layout of Rooms (from Room Layouts diagrams, Section 3.2)

2] Set REMOTE inputs (if used) as MOMENTARY or CONTINUOUS

Controller rear-panel control inputs must be set to MOMENTARY (factory default) if a remote pushbutton panel is to be used to select room configurations. These inputs are set to CONTINUOUS if the controller is intended to switch automatically based on continuous closures provided by external switches (example: magnetic switches triggered by the position of moving partitions). Note: If the CONTINUOUS mode is selected, then applying an external switch closure to a particular input will over-ride and disable the associated front-panel button until the switch opens. In the absence of an external closure, the front-panel buttons will function normally.

3] Select INDEPENDENT or TANDEM room level control

TANDEM control (factory default) allows *any* RCX Room Control to adjust the level simultaneously in *all* the rooms comprising the larger combined room. (The TANDEM mode may be preferred in systems that allow overhead speakers to be disabled in the area where microphones are used, or that have feedback controllers installed.) INDEPENDENT control allows the level in each room to be independently adjusted when the room is part of a larger combined room. (This setting may be preferred in installations that do not have feedback control or the provision to turn off overhead loudspeakers in the area where microphones are used.)

4] Select TANDEM or MUSIC LOCKOUT source selection

TANDEM control (factory default) allows *any* RCX Room Control that provides source selection to select the **MUSIC** or **LOCAL** source simultaneously in *all* the rooms comprising the larger combined room. MUSIC LOCKOUT mode disables the MUSIC source selection in any room *that is combined*. This setting may be preferred by a facility wishing to preclude the possibility of background music being turned on after a combined room has been set up.

3.1.2 Optional:

The controller allows the installer to store PRESET audio volume levels for each room. This setup may be done only after completion of physical installation and wiring of the system. Two separate preset levels are stored per room; one for the **MUSIC** input, one for the **LOCAL** input. Storing the correct level for a 'typical' room use will facilitate subsequent system operation. For example, a mic can be set up in a room, and a room combination selected on the controller. Selecting the room combination sets the associated room audio sources to **LOCAL** and sets the volume to the stored value. Therefore, no further action is required to prepare for normal room use; level changes can always be made in the room if desired.

As shipped from the factory, the RCX Room Control audio level will be halfway up when either input is selected in any room. The factory setting allows levels to be adjusted +/- 18 dB in each room. This range is suitable for many facilities, simplifying installation by making level storage unnecessary.

3.1.3

If the TANDEM control mode is active and a room is made part of a combination, its source is set to **LOCAL** and the level is set to PRESET. If the INDEPENDENT control mode is active, a newly combined room's level will go to the last stored local level if the **IND RM LEVEL** switch is set to the **LAST** position. The audio level in the room may then be adjusted to a different volume. If **MUSIC** is selected in the combined room, the last **LOCAL** level setting is stored in memory. Upon reselecting **LOCAL**, the volume returns to the last level. In a room that is *not* part of a combination, the **LOCAL** level can be set to return either to PRESET or to the **LAST LOCAL** level setting when the room source is switched from **MUSIC** to **LOCAL**. If the RCX-5C rear panel **IND RM LEVEL** switch is set to the **PRST** PRESET position, the audio level will always return to the stored local preset level when a user switches the room source from **MUSIC** to **LOCAL**. If the RCX-5C rear panel **IND RM LEVEL** switch is set to the **LAST** position, the audio level will always return to the previous local level when a user switches the room source from **MUSIC** to **LOCAL**.

3.2 INSTRUCTIONS FOR SELECTING ROOM CONFIGURATION

1] Hold Button 1 in while powering up the controller; release it when the LED above it turns on. The LED above Button 1 will flash to indicate the ROOM CONFIGURATION setup mode is active. It will continue to flash until the configuration settings are saved.

(Note: DO NOT push Button 1 again until you are done selecting the correct configuration settings. Pushing Button 1 stores the configuration and exits the configuration mode. If you accidentally push Button 1 prematurely, you may re-enter the configuration mode by repeating Step 1.)

2] Find your room layout from the diagrams on the following pages. Set the rear-panel MODE SWITCH to the position shown. Then set the button LEDs *on* or *off* as shown on the button diagram associated with your layout. The LEDs toggle on/off each time buttons are pushed.

(Note: If you push a button that would also require another LED to be set 'on' (or 'off'), the controller will automatically set the other LED(s) 'on' (or 'off') to simplify your setup. If no MODE SWITCH position is indicated, then the switch may be in any position.)

3] Set the **REMOTE CONTROL** input terminals for CONTINUOUS closure operation if desired. (Factory default is MOMENTARY.) CONTINUOUS operation is selected by toggling Button **ALL** LED *on*. (CONTINUOUS mode is used if the RCX-5C is controlled by external switches activated by wall positions.)

4] Push Button 1 to save your settings. LED 1 will stop flashing and the system enters the normal operating mode.

Room Layout Diagrams

2 ROOM SYSTEM

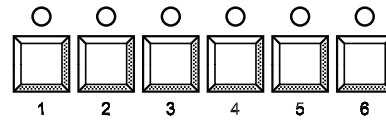
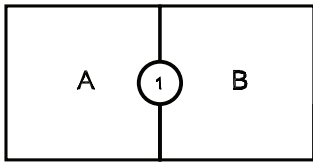

FRONT PANEL BUTTONS / LEDS

ANY POSITION



REAR PANEL MODE SWITCH

3 ROOM SYSTEMS

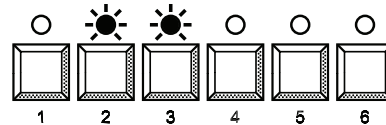
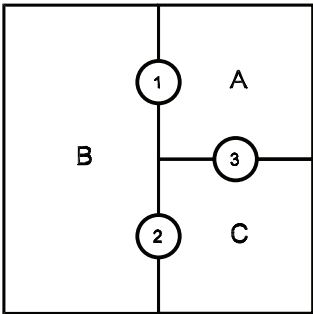

FRONT PANEL BUTTONS / LEDS



REAR PANEL MODE SWITCH

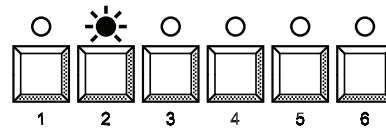
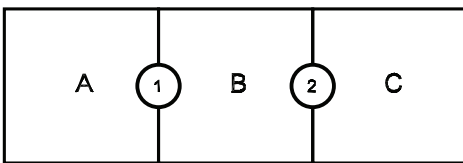

FRONT PANEL BUTTONS / LEDS

ANY POSITION



REAR PANEL MODE SWITCH

4 ROOM SYSTEMS

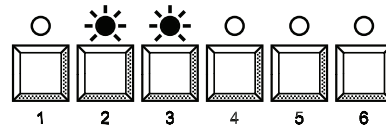
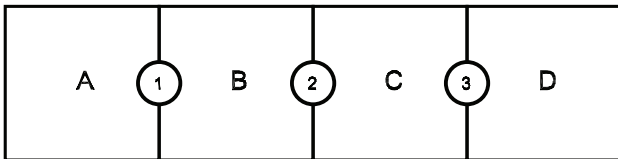

FRONT PANEL BUTTONS / LEDS



REAR PANEL MODE SWITCH

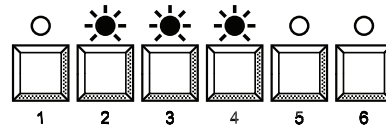
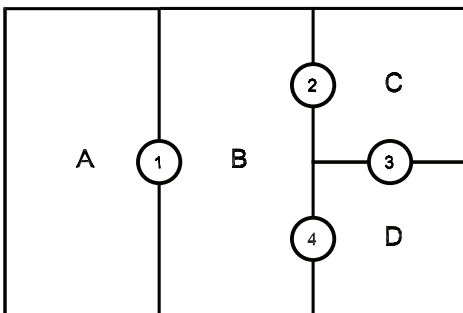

FRONT PANEL BUTTONS / LEDS



REAR PANEL MODE SWITCH

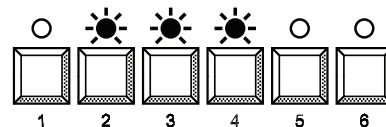
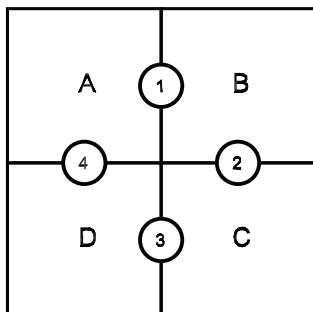

FRONT PANEL BUTTONS / LEDS



REAR PANEL MODE SWITCH

4 ROOM SYSTEMS (CONTINUED)

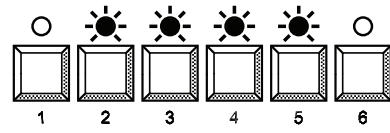
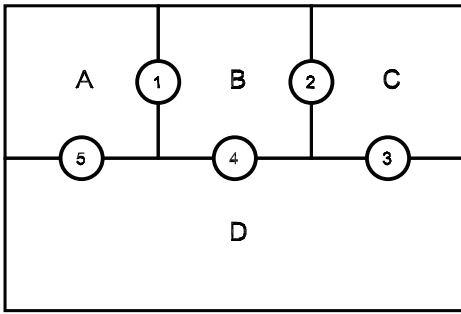

FRONT PANEL BUTTONS / LEDS



REAR PANEL
MODE SWITCH

5 ROOM SYSTEMS

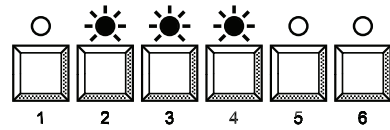
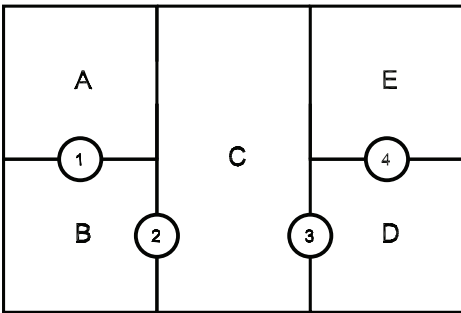

FRONT PANEL BUTTONS / LEDS



REAR PANEL
MODE SWITCH

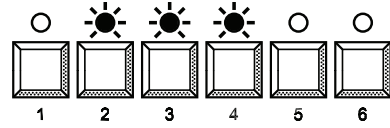
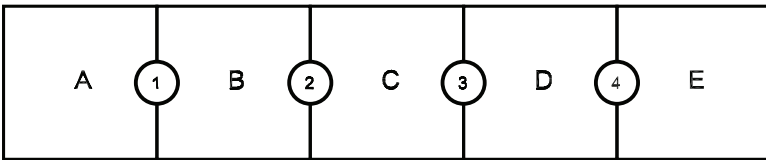

FRONT PANEL BUTTONS / LEDS



REAR PANEL
MODE SWITCH

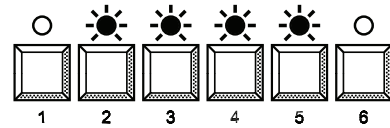
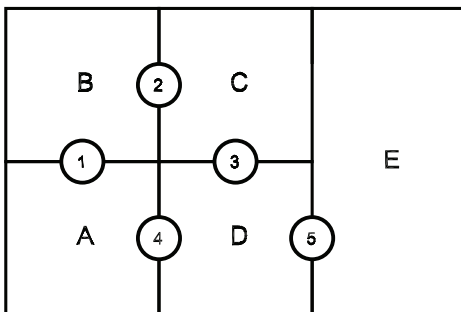

FRONT PANEL BUTTONS / LEDS



REAR PANEL
MODE SWITCH

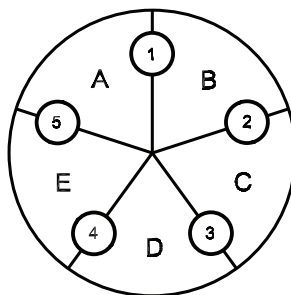
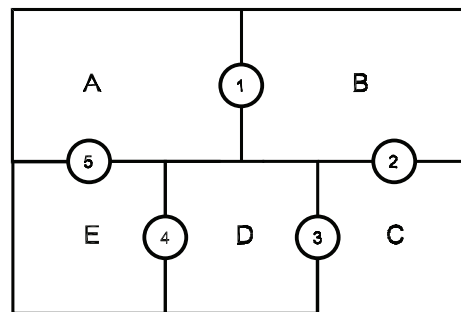

ALTERNATE LAYOUT

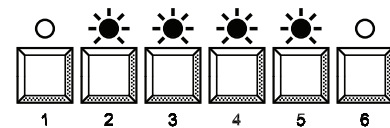

FRONT PANEL BUTTONS / LEDS



REAR PANEL
MODE SWITCH

3.3 INSTRUCTIONS FOR SETTING POWER AMPLIFIER LEVELS

3.3.1 **Required:**

(Note: Experienced installers may save considerable time by consolidating related steps for setting and storing levels. The following individual steps are presented to ensure trouble-free installation and a thorough understanding of the controller operation.)

The controller audio output for each room is a nominal +4 dBu line level to feed the power amplifier used for that room. Before storing preset levels in the controller, it is first necessary to set the power amplifier gain. Once set, the power amplifier gain controls should be secured against tampering.

- 1] Turn the power amplifier gain to the *off* position.
 - 2] Connect the typical mic or mixer that will be used in Room **A**. Speak into the mic to verify the correct audio level at the controller, as indicated by the dual-LED VU meter on the front panel. If required, adjust the front panel knob associated with Room **A** for correct operating level (green LED as bright as possible, with the red LED flashing only occasionally).
 - 3] In Room **A**, select **LOCAL** source on the RCX Room Control and ramp the audio level fully up, indicated by the uppermost red LED on the level LED string.
 - 4] Adjust the gain of the room's power amplifier for the maximum level desired. This may be the highest level possible without feedback.
- (If acoustic conditions produce feedback at an insufficient audio level, a line-level audio equalizer should be installed between the controller audio output and the power amplifier input. An example is: RDL FP-PEQ3 3-band Parametric Equalizer.)
- 5] Ramp the RCX Room Control level to the *off* position (lowest red LED illuminated), and repeat steps 2], 3], 4] and 5] for all other rooms.

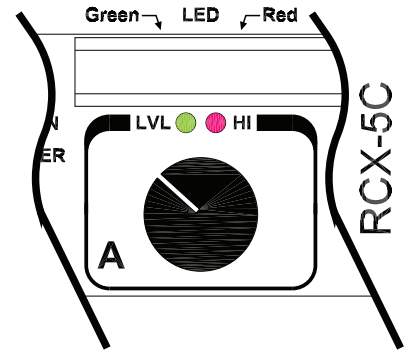

3.3.2 **Optional:**

After setting the input gains (3.3.1, step 2] above), the installer may wish to protect the RCX-5C against unauthorized adjustment. The level controls on the front of the RCX-5C are intended to be adjusted occasionally if different mics or mixers are used in a particular setup. The RCX-5C is supplied with a provision to protect against unwanted level adjustment. Five plastic caps are provided, which may be used to replace the front-panel knobs. The caps have a small hole in the center that allows access for a standard alignment screwdriver. To install the caps, first remove the knobs by snapping out the knob cap, loosening the screw and removing the knob. Snap the plastic cap in place.

3.4 INSTRUCTIONS FOR STORING PRESET LEVELS

'Preset' levels may be 'permanently' stored at any time during normal operation. Each level remains stored until it is changed and stored again. During routine operation, the volume in a room will return to the preset level when the **MUSIC** source is selected or when the room is first combined with another room. In an uncombined room, the volume will return to the preset level when **LOCAL** is selected, provided the rear panel selector is set for that function (see 3.1.3). Two levels may be stored for each room. One level is stored for the **MUSIC** source, typically a low level for background music. A second preset level is stored for the **LOCAL** source, typically the normal public address operating level for combined rooms chosen by the installer.

(Note: Factory default preset levels are 18 dB below maximum; storing new levels is optional. The default setting is shown on the RCX Room Control level indicator as 5 of 10 LEDs illuminated, allowing a nominal user adjustment of +/- 18 dB.)

1] Set the level in each room to the *off* condition, as indicated by the bottom red LED on the RCX Room Control. A special utility in the RCX-5C allows setting all room levels *off* at the controller. On the back of the controller, remove power, then reconnect power while holding the **PRESET** button in. After connecting power, release the **PRESET** button and the RCX-5C resumes normal operation with all RCX Room Controls in the *off* position. The *stored* 'preset' levels are *not* changed by this operation.

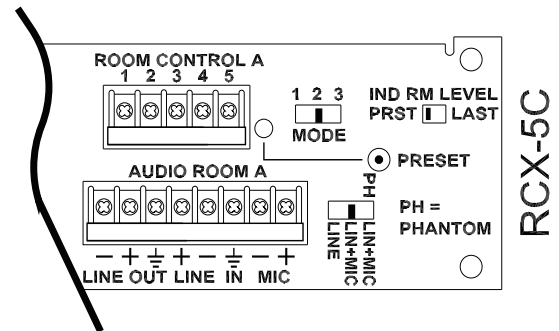

*(Note: The level storage mode is only enabled if **one** room level is turned up. If two or more RCX Room Controls are turned up [not 'off'] then level storage is not allowed. Also, if no RCX Room Controls are turned up, then storage is not allowed.)*

(Note: If power fails and is restored during normal operation, audio returns to the local mode preset level.)

2] Connect the typical mic or mixer that will be used in Room **A**. Speak into the mic to verify the correct audio level at the controller, as indicated by the dualLED VU meter on the RCX-5C front panel. If required, adjust the frontpanel knob associated with Room **A** for correct operating level (green LED as bright as possible, with red LED flashing only occasionally).

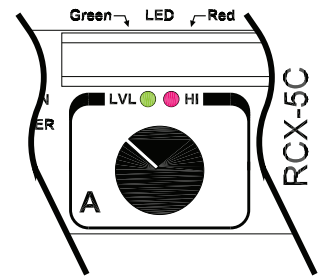

3] In Room **A**, select **LOCAL** source on the RCX Room Control and adjust the audio level for desired volume.

4] Press the **PRESET** button on the rear of the controller. The red LED on the rear panel will illuminate (steady) for 3 seconds, indicating the value is stored.

*(Note: If the red LED **flashes**, the value is **not** stored. This error condition occurs if more than one RCX Room Control is set to a level other than 'off' or if all Room Controls are 'off'. Ramp the levels down to 'off' in all rooms [see step 1 in this section] except the room you wish to store, then repeat this step.)*

5] Ramp the level down to *off* in Room **A**. Repeat steps 2], 3], 4] and 5] for the other installed rooms.

(Note: It is not necessary to store values for every room. If the factory default 'half volume' is desired in some rooms, then store new values only for the rooms requiring different preset levels.)

If background music is not used in your installation, skip to step 10].

6] Verify the correct audio level of the music source on the controller, as indicated by the dual-LED VU meter on the front panel. If required, adjust the rear-panel music level trimmer for correct operating level (green LED as bright as possible, with red LED flashing only occasionally).

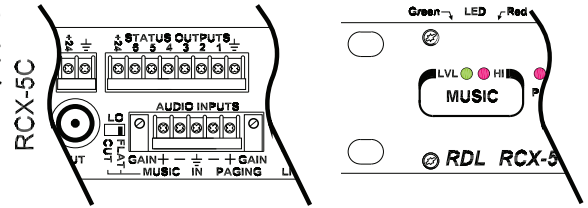

7] In Room **A**, select **MUSIC** source on the RCX Room Control and adjust audio level for desired volume using the UP and DOWN buttons (RCX-1, D-RCX1), using the rotary encoder (RCX-2, D-RCX2, RCX-10R, D-RCX10R) or using the key switch (RCX-3).

*(Note: If the room is combined with another room, the **MUSIC** source button on the RCX Room Control may be locked out by the controller.)*

8] Press the **PRESET** button on the rear of the controller. The red LED on the rear panel will illuminate (steady) for 3 seconds, indicating the value is stored.

*(Note: If the red LED **flashes**, the value is **not** stored. This error condition occurs if more than one RCX Room Control is set to a level other than 'off', or if all Room Controls are 'off'. Ramp the levels down to 'off' in all rooms except the room you wish to store, then repeat this step.)*

9] Ramp the level down to *off* in Room **A**. Repeat steps 6], 7], 8] and 9] for the other installed rooms.

If paging is not used in your installation, skip step 10].

10] Connect the **PAGING** control terminal to ground to activate the paging mode. Apply line level paging audio to the **PAGING** audio input. Adjust the controller rear-panel paging trimmer control for the desired audio level. The level will be the same for all rooms regardless of which source (**MUSIC** or **LOCAL**) is selected in that room. Paging overrides both the source and level settings on each RCX Room Control. Disable **PAGING** after adjustment to return to normal operation.

The level settings are complete.

3.5 INSTRUCTIONS FOR TANDEM CONFIGURATION SETUP (SETTING TANDEM OR INDEPENDENT LEVEL CONTROL AND FOR SETTING TANDEM OR MUSIC LOCKOUT SOURCE SELECTION)

TANDEM OR INDEPENDENT LEVEL CONTROL: As supplied from the factory, the volume control in each *combined* room adjusts the audio level in the entire combined area. This is called the TANDEM level control mode. Installations without feedback controllers or a provision to turn off speakers located over microphone locations may benefit from independent level control. When the INDEPENDENT mode is set, the volume is adjusted individually in each combined room in a combined area. (This permits the staff to reduce the volume in the room where mics are set up while setting the volume louder in the rest of the combined room.) The RCX-5C may be toggled between the INDEPENDENT mode or the default TANDEM mode. (In the TANDEM mode, all room volume controls in a combined room will adjust the level in the entire combined room. When first combined, the room level is set to the **LOCAL** preset level. Subsequent switching from the **MUSIC** to the **LOCAL** source in the combined room causes the **LOCAL** level to return to the last **LOCAL** level setting.)

TANDEM OR MUSIC LOCKOUT SOURCE SELECTION: As supplied from the factory, the source selector (if the Room Control is equipped with source selection) in each *combined* room will select the **MUSIC** or **LOCAL** source for the entire combined area. This is called the TANDEM source selection mode.

Some facilities may prefer that the **MUSIC** source be locked out (unavailable) in a combined area. When the MUSIC LOCKOUT mode is active, the **MUSIC** button on each Room Control in a combined area will not change the source when pushed. (The **MUSIC** LED will flash to acknowledge the button, but the source will remain in **LOCAL**.) Most systems are designed with similar Room Controls in each room; if background music is used at all, it is typically used in all rooms. It is possible to install an RCX system with source selection (**MUSIC** or **LOCAL**) in some, but not all, rooms. If *any* room in a system using background music is equipped *only* with a room control that does *not* provide source selection, then the MUSIC LOCKOUT mode *must* be chosen.

Note: If none of the Room Controls in the system have source selection, then the RCX-5C may be set to either MUSIC LOCKOUT or INDEPENDENT source selection mode.

The following setup allows the installer to set the modes that will be applied every time a room combination is selected. These settings are used permanently unless they are changed in the future using this procedure:

- 1] Remove power from the RCX-5C, if it is powered.
- 2] Hold down Button **ALL** while connecting power to the RCX-5C. The LED above Button **ALL** will flash, indicating the TANDEM CONFIGURATION SETUP is active. It will continue to flash until the configuration settings are saved.
- 3] Observe the Button **1** LED. If it is on, the RCX-5C is set for TANDEM level control. Press Button **1** to toggle the level control to INDEPENDENT, if desired. Pushing Button **1** alternates the mode between TANDEM and INDEPENDENT.
- 4] Observe the Button **2** LED. If it is on, the RCX-5C is set for TANDEM source selection. Press Button **2** to toggle the source selection to the MUSIC LOCKOUT mode. Pushing Button **2** alternates the mode between TANDEM and MUSIC LOCKOUT.
- 5] Push Button **ALL** to save your settings. LED **ALL** will stop flashing and the system enters the normal operating mode.

4. Equipment Planning and Wiring

All RCX components are designed to be connected using readily available standard wire and cable types. For ease of testing and troubleshooting, audio wiring carries standard analog audio signals. Control wiring carries power and dc voltages. Command pushbuttons shift dc levels permitting easy wiring verification using a multimeter. All terminals providing dc power from the RCX-5C are protected against accidental shorts. Automatically resetting fuses remove power from shorted wiring and restore power when the wiring fault is corrected. Long control cable runs require heavier gauge wires as detailed in Section 2.2.

4.1 EQUIPMENT MOUNTING AND PREWIRING REQUIREMENTS

4.1.1 COMMON EQUIPMENT LOCATION / SYSTEM CONTROLLER(S)

Each system is controlled by an RCX-5C Controller. The RCX-5C mounts in an equipment rack with its power supply (RDL PS-24V2) and the room power amplifiers. A typical system (providing a single microphone input and a stereo unbalanced line input in each room) does not require any additional mixing equipment. If multiple inputs are desired in each room, audio mixers may be either rack mounted with the RCX-5C or may be wall mounted in each room. RDL offers a range of mixers for this purpose. The RCX-5C occupies 1RU and requires ventilation within the rack. It is recommended that the equipment mounted in the rack unit above and below the controller be no deeper than 2 inches (5 cm), or use an RDL RM-FP1 filler panel. RDL Rack-Up series products and RCX-CD1(L) custom control panels may be mounted directly above and below an RCX-5C controller. The PS-24V2 power supply may be optionally rack mounted using an RDL RU-RA3 rack adapter and RU-PSB1A power supply bracket.

SUMMARY

MOUNTING: RCX-5C requires 1 rack unit, allow 1RU above and below for ventilation

ELECTRICAL: 24 Vdc, 2 A from RDL PS-24V2

4.1.2 ROOM AUDIO INPUT(S)

Each room must be equipped with at least one input. The RCX-5C has two inputs per room, one **MIC** and one **LINE**. Each input is balanced and may be wired unbalanced. Typical installations use either an RCX-J1 or D-J1 (single microphone jack assembly), an RCX-J2 or D-J2 (summed stereo phono jack line input) or an RCX-J3, D-J3 (single microphone jack plus a summed stereo phono jack line input). If the -J1 or -J2 is used, a single shielded pair is required from the room to the rack. If the -J3 is used, two shielded pairs (in either a separate or common jacket) are required from the room to the rack. If additional inputs are to be used, the installer may use RCX-J1, D-J1, RCX-J2, D-J2, RCX-J3 or D-J3 assemblies as inputs to a separate mixer. The mixer is used to feed the line level input of a given room input on the RCX-5C.

SUMMARY

MOUNTING: RCX-J1, D-J1, RCX-J2, D-J2, RCX-J3, D-J3 mounts in RDL WB-1U wall box or single US electrical box

WIRING: RCX-J1, D-J1, RCX-J2, D-J2: Single shielded pair ; RCX-J3, D-J3: Two shielded pairs

4.1.3 ROOM AUDIO CONTROL (LEVEL AND SOURCE)

Each room is also equipped with an RCX Room Control for adjusting volume and selecting the audio source (facility music source or local room inputs). If no system music source is desired in any or all rooms, install an RCX Room Control without source selection. A typical system is installed with RCX-1 or D-RCX1 Room Controls (pushbutton volume [up/down], plus pushbutton source selection [**MUSIC/LOCAL**]). For customers desiring rotary level control, the system is installed with RCX-2 or D-RCX2 Room Controls (rotary encoder volume [up/down], plus pushbutton source selection [**MUSIC/LOCAL**]). For customers desiring keyed operation, the system is installed with RCX-3 Room Controls (mechanical key switch for volume [up/down], mechanical key switch to select source).

Wiring from the RCX Room Control to the rack is identical for each of these controllers. Five conductors are required, one of which is grounded and may be a shield. These may be 5 individual conductors, 2 shielded pairs or 4 conductors plus a separate ground. Cat 5 wire or equivalent may be used. Control is dc, allowing verification using a simple multimeter and requiring no special data wiring precautions.

SUMMARY

MOUNTING: RCX-1, RCX-2, RCX-3 mount in RDL WB-2U wall box or double US electrical box
*Note: If US electrical box uses a mud ring, replace mud ring with RDL MR-2;
(Some mud rings have large radii that interfere with RCX product mounting).
D-RCX1, D-RCX2 mount in RDL WB-1U wall box or single US electrical box*

WIRING: 5 conductors 24 gauge or heavier (see Section 2.2), or two shielded pairs audio wire

4.1.4 ROOM AUDIO CONTROL (LEVEL ONLY)

For systems not using a music source, the RCX-10R, D-RCX10R, RCX-3R or RCX-3RS Room Controls may be used. The RCX-10R and D-RCX10R are rotary optical encoders with an LED virtual position pointer. The RCX-3R and RCX-3RS are key operated panels with an LED virtual position pointer. Four conductors are required from the RCX-5C to any of these Room Controls. One of the four conductors is grounded and may be a shield. These may be 4 individual conductors or 3 conductors plus a ground or shield. Cat 5 or equivalent may be used. Control is dc, allowing verification using a simple multimeter and requiring no special data wiring precautions.

SUMMARY

MOUNTING: RCX-10R or D-RCX10R mounts in RDL WB-1U wall box or single US electrical box

WIRING: 4 conductors 24 gauge or heavier (see Section 2.2)

4.1.5 MULTIPLE ROOM AUDIO CONTROLS

A typical system has a single RCX Room Control in each room. It is possible to provide one or two RCX Room Controls in each room. Any two models of RCX Room Controls may be installed in a single room. For example, an RCX-2 or D-RCX2 may be installed at a primary location in a room, providing level and source selection. Four conductors may be extended from the RCX-2 or D-RCX2 to an RCX10R or D-RCX10R located elsewhere in the same room. The RCX-10R or D-RCX10R would provide level control from its location, but not source selection. If two RCX-1, D-RCX1, RCX-2 or D-RCX2 Room Controls are installed in a single room, level adjustment and source selection are available at both locations. The level LED virtual pointers on each control will track each other.

*Note: If any room in a system that uses background music is equipped **only** with Room Controls that do not provide source selection [RCX-10R, D-RCX10R, RCX-3R, RCX-3RS], then the MUSIC LOCKOUT mode **must** be programmed. (See Section 2.1 or 3.5)*

4.1.6 ROOM COMBINATION CONTROL PANELS

Selection and installation of the appropriate components above comprises a complete system. Room combinations are chosen using the front-panel buttons on the RCX-5C based on a chart (matching the layouts in Section 3.2) provided by the installer. It is often simpler for facility staff to operate a system using a graphic layout with integral control pushbuttons. The RCX-CD1(L) custom control and display panel is used for this purpose. A customized RCX-CD1(L) is available from RDL for each RCX installation. The RCX-CD1(L) may be installed in the equipment rack with the RCX-5C, or it may be mounted remotely (in a hallway, kitchen, front desk or office). For remote wall mounting, the RCX-CD1(L) mounts in an RCX-BZL wall bezel available separately. Fifteen conductors fully connect an RCX-CD1 to an RCX-5C. Multiple RCX-CD1 panels may be connected to a single RCX-5C; 24 gauge or heavier wire is recommended. Cat 5 or equivalent is suitable. Control is dc, allowing verification using a simple multimeter and requiring no special data wiring precautions. The RCX-CD1 is available with or without a mechanical key lock.

SUMMARY

MOUNTING: RCX-CD1(L) requires 4 rack units in equipment rack, or wall mounts in RDL RCX-BZL

WIRING: 15 conductors, 24 gauge or heavier (see Section 2.2)

4.1.7 LINKING TWO GROUPS OF ROOMS (TWO CONTROLLERS)

In larger facilities, it may be desired to combine groups of rooms together. The RCX-5C controller comes equipped with a LINK function. A standard stereo patchcord connects between two controllers. If **ALL** is selected on *both* controllers, then all audio inputs on both controllers feed all outputs on both controllers.

SUMMARY

WIRING: Standard stereo patchcord, phono (RCA) plugs

4.1.8 MUSIC SOURCE

System background music may be connected to the RCX-5C. The input is balanced and a 25-turn gain trimmer is provided on the rear of the RCX-5C. A front-panel dual-LED VU meter indicates the music level. The connected source signal may be unbalanced or balanced (nominal -10 dBV or +4 dBu).

SUMMARY

WIRING: Single shielded pair audio wire

4.1.9 PAGING SOURCE AND CONTROL

Paging may be connected to the RCX-5C. Activation of the paging function requires an external closure to ground. When paging is activated, all audio sources in the RCX-5C are disrupted and the paging signal is fed to all five power amplifier outputs, regardless of the programmed room configuration. The paging input is normally used for emergencies rather than routine paging. The paging input is line level (balanced, nominal +4 dBu) with a 25-turn gain trimmer on the rear of the RCX-5C.

SUMMARY

WIRING: Audio: Single shielded pair audio wire; Control: Single conductor (closure to ground / audio shield)

4.1.10 OPEN COLLECTOR STATUS OUTPUTS

The RCX-5C provides a **STATUS** output (open collector) representing each wall. The output is pulled low if a wall is open, indicating the adjacent rooms are combined. These status outputs are used to drive the indicators on the remote RCX-CD1 panels. They may also be used by the installer to control other RDL modules. They may even be used to activate automatic walls provided sufficient safeguards are in place to safely allow wall movement to be triggered from the RCX-5C.

4.1.11 CONTROL INPUTS

The RCX-5C provides control inputs that select or deselect room combinations. These inputs are normally used to receive momentary button closures to ground from the RCX-CD1 control panels. If it is desired to use mechanical, magnetic or similar switches to detect wall positions, these control inputs may be programmed for continuous closures (See Section 3.2) to ground. In this mode, an RCX-CD1 cannot be connected.

4.1.12 AUDIO RECORDING OUTPUTS

The RCX-5C balanced line outputs for each room normally feed the power amplifier for that room. Each output may also be connected to an RCX-A2 or D-A2 Audio Output panel in the associated room. The RCX-A2 or D-A2 panel makes the room audio signal available for recording on consumer devices. The RCX-A2 or D-A2 has two phono jack outputs to feed mono or stereo recording equipment. The outputs are transformer isolated. Integral attenuation prevents signals accidentally injected into the RCX-A2 or D-A2 from being amplified by the room power amplifier.

SUMMARY

WIRING: Single shielded pair audio wire

4.2 EQUIPMENT WIRING

4.2.1 ROOM AUDIO INPUT WIRING

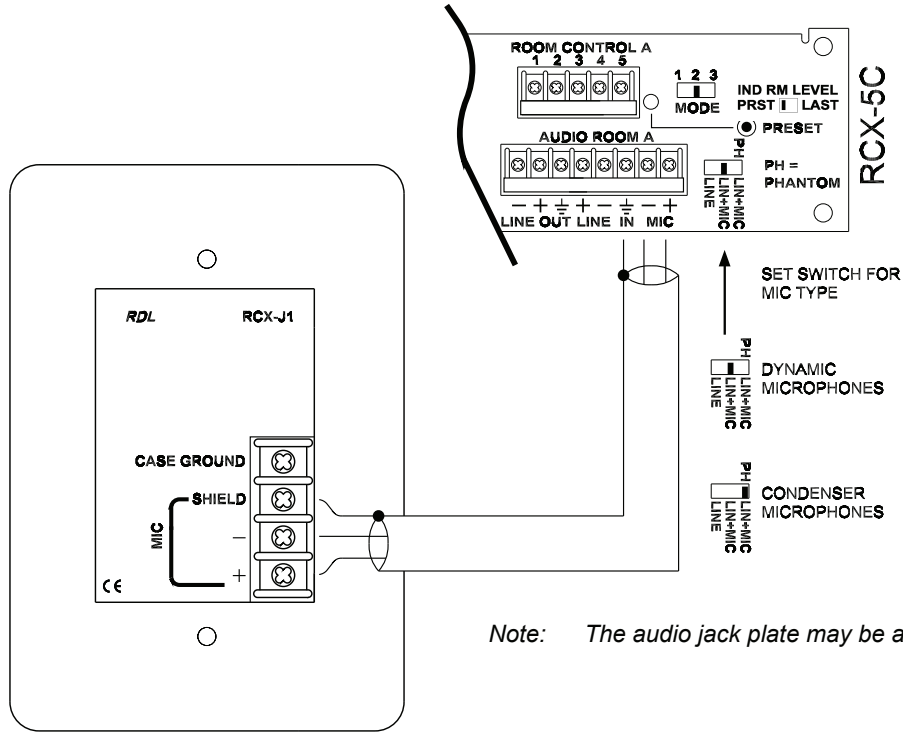

ROOM AUDIO INPUT - MICROPHONE ONLY

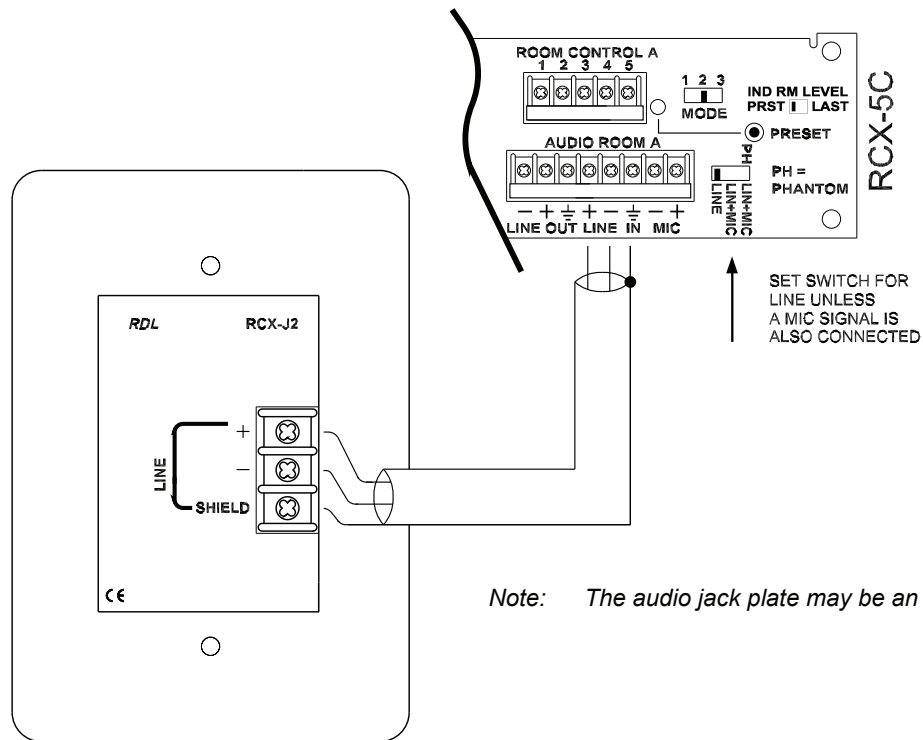

ROOM AUDIO INPUT - UNBALANCED LINE LEVEL ONLY

4.2.1 ROOM AUDIO INPUT WIRING

Note: The audio jack plate may be an RCX-J3 or D-J3 style.

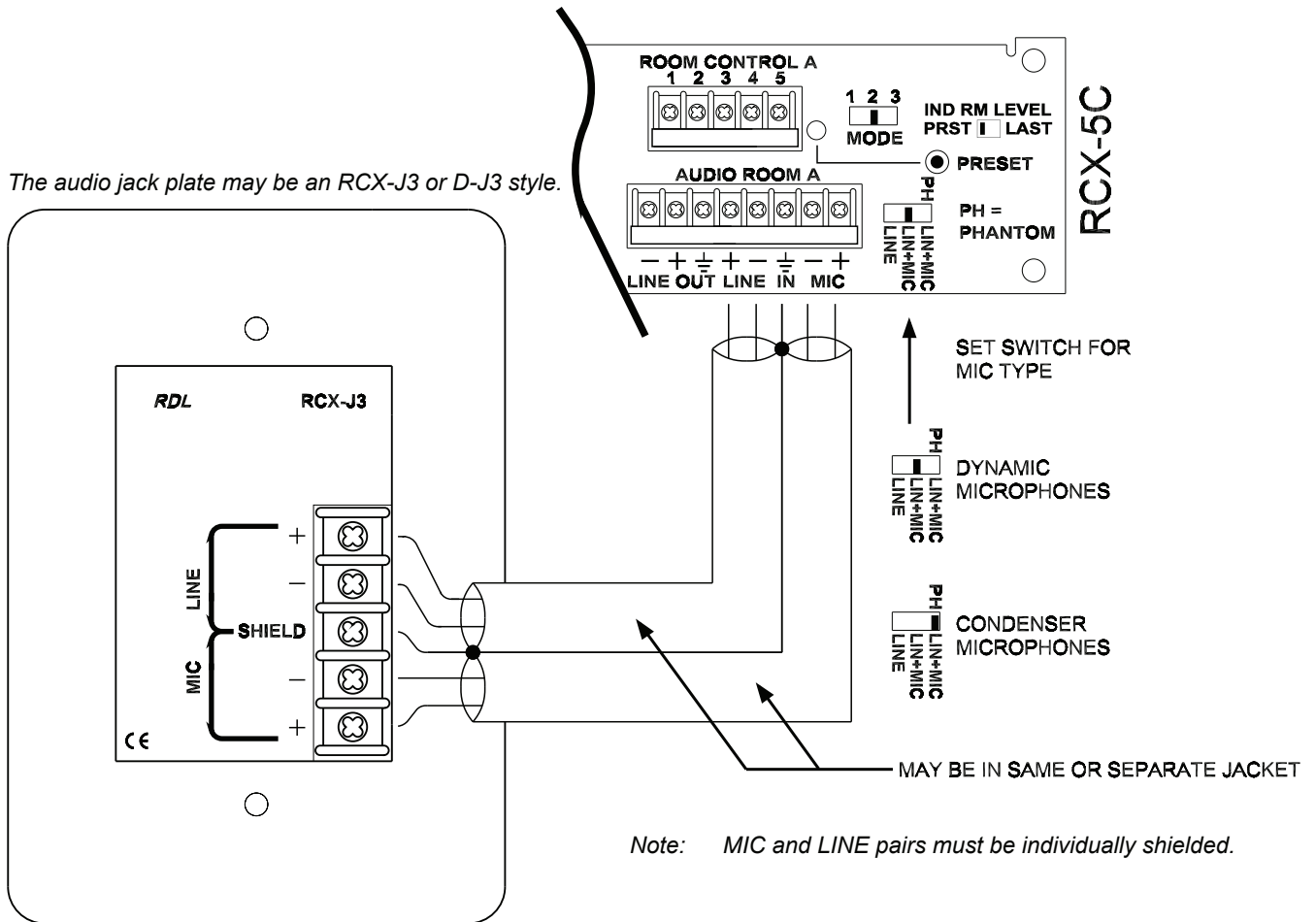

ROOM AUDIO INPUT - MICROPHONE AND LINE

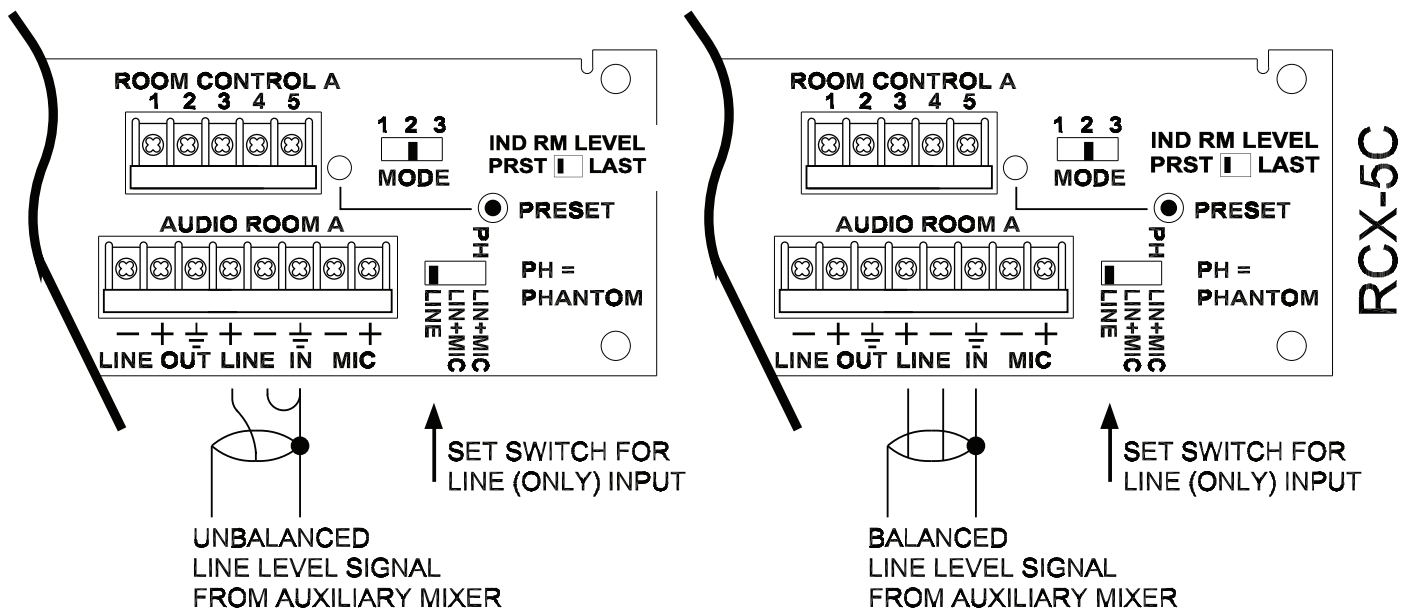

Note: Unbalanced wiring should only be used if the mixer is located in the same equipment rack as the RCX-5C. Unbalanced wiring should not be used for signals originating in rooms. Balanced wiring is recommended.

ROOM AUDIO INPUT FROM AUXILIARY AUDIO MIXER IN ROOM OR RACK

4.2.2 AUDIO OUTPUT WIRING

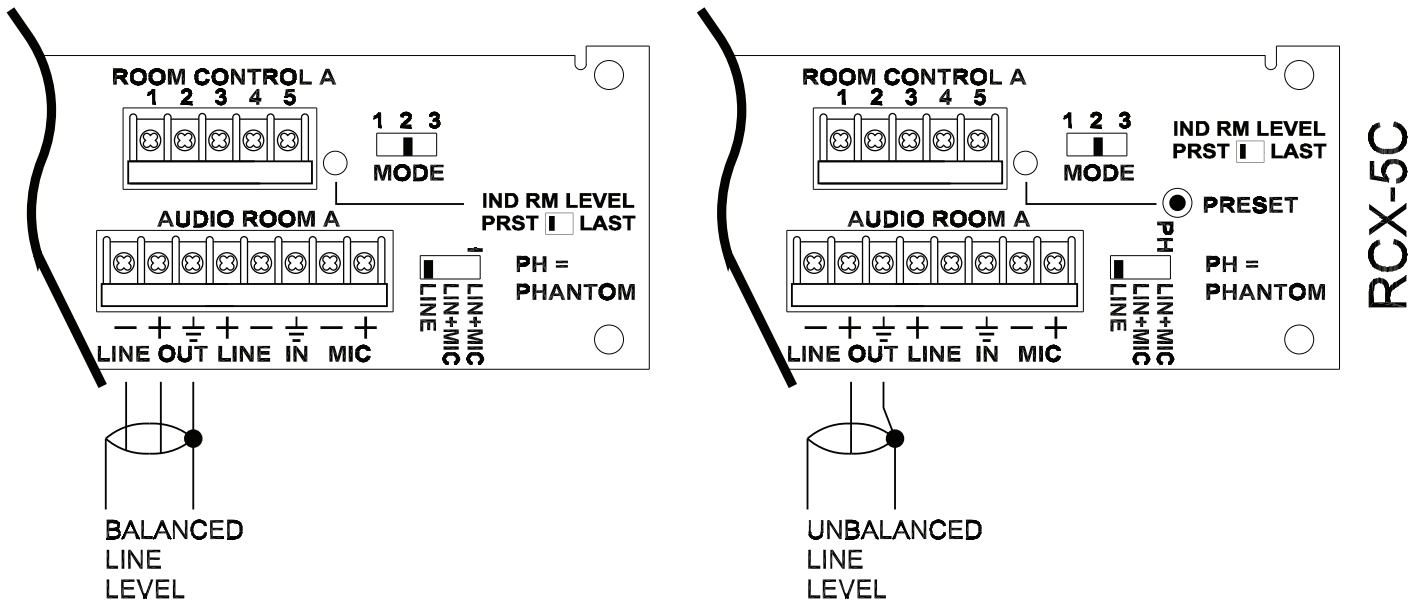

SIGNAL FEEDING POWER AMPLIFIERS FOR EACH ROOM

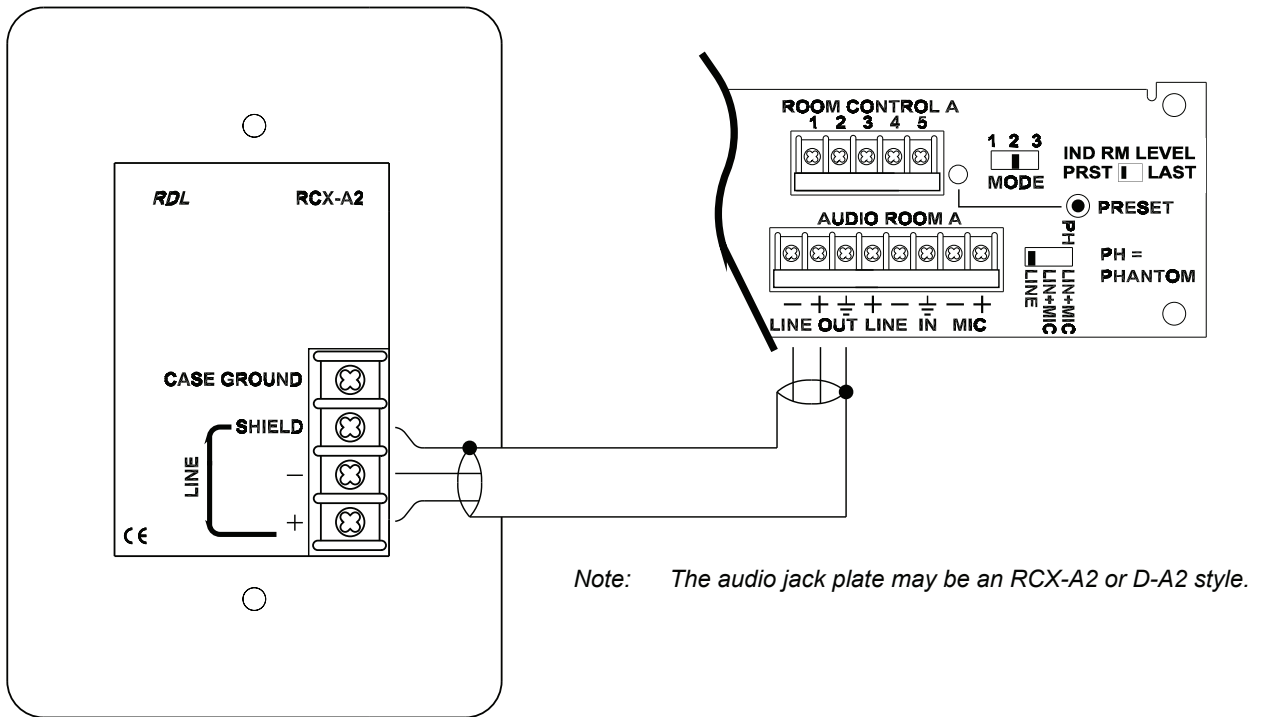

SIGNAL FEEDING RECORDING PANEL IN EACH ROOM

4.2.3 RCX ROOM CONTROL WIRING

(Shielded wires shown for high rf fields and CE compliant installations.)

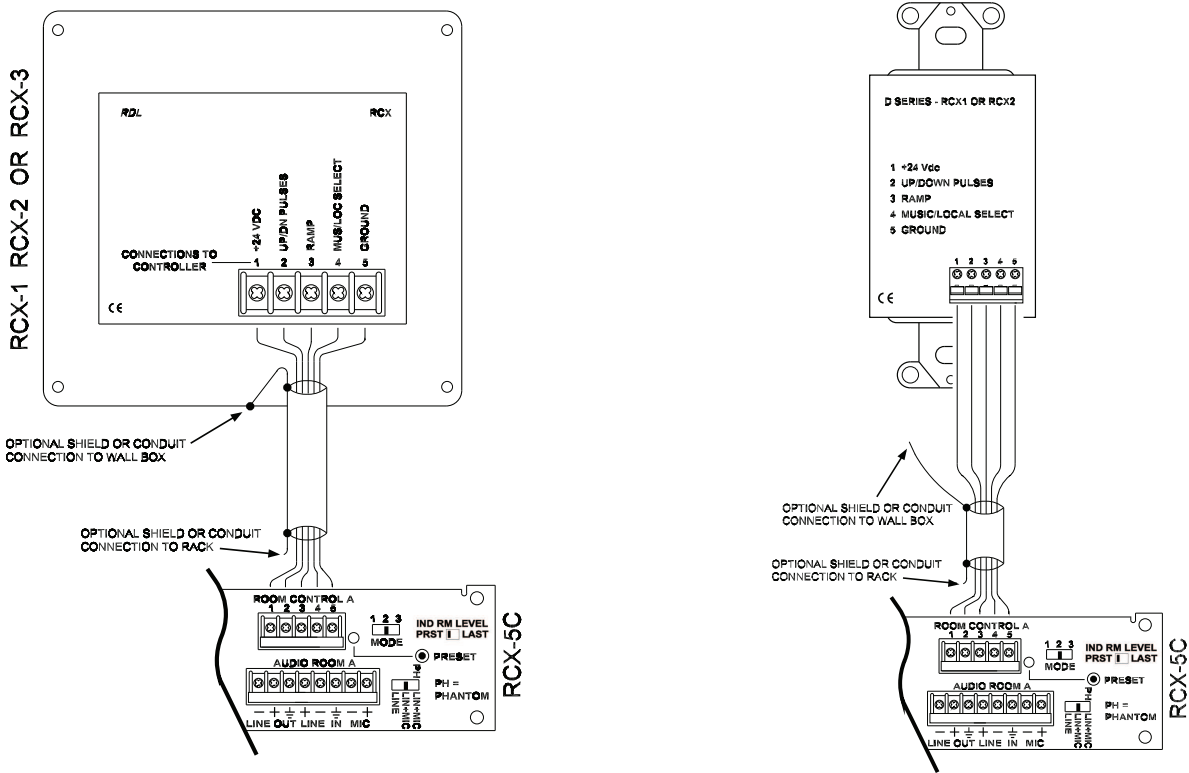

SINGLE CONTROL IN A ROOM (VOLUME AND MUSIC/LOCAL SELECTION)

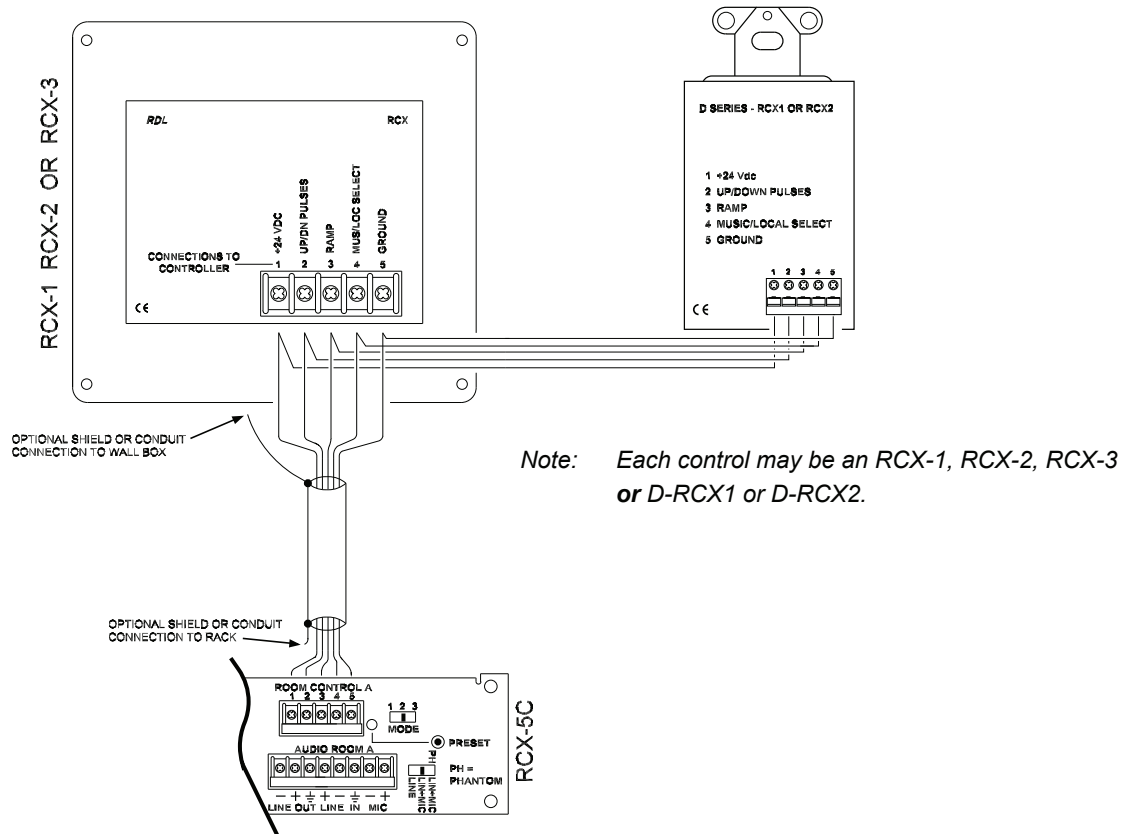

TWO CONTROLS IN A ROOM (VOLUME AND MUSIC/LOCAL SELECTION)

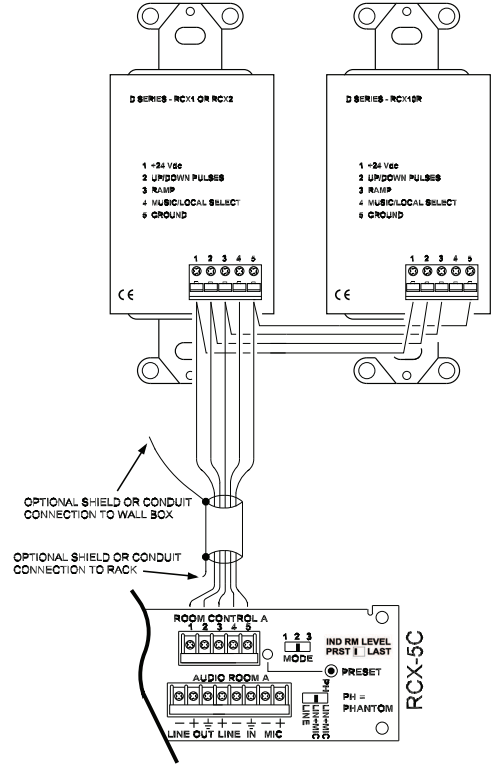
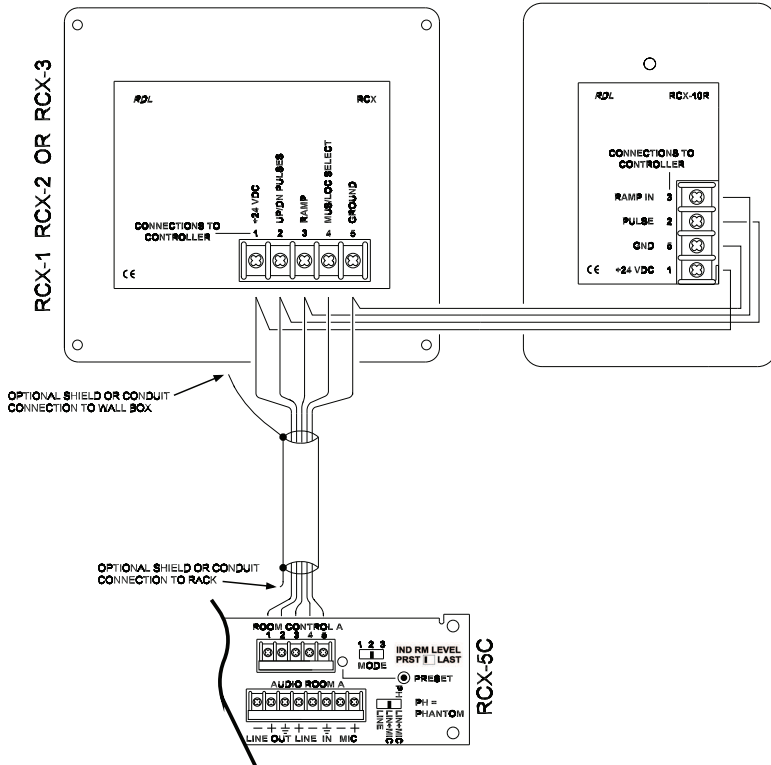

TWO CONTROLS IN A ROOM (ONE CONTROL WITH VOLUME AND MUSIC/LOCAL SELECTION;
ONE CONTROL WITH VOLUME ONLY)

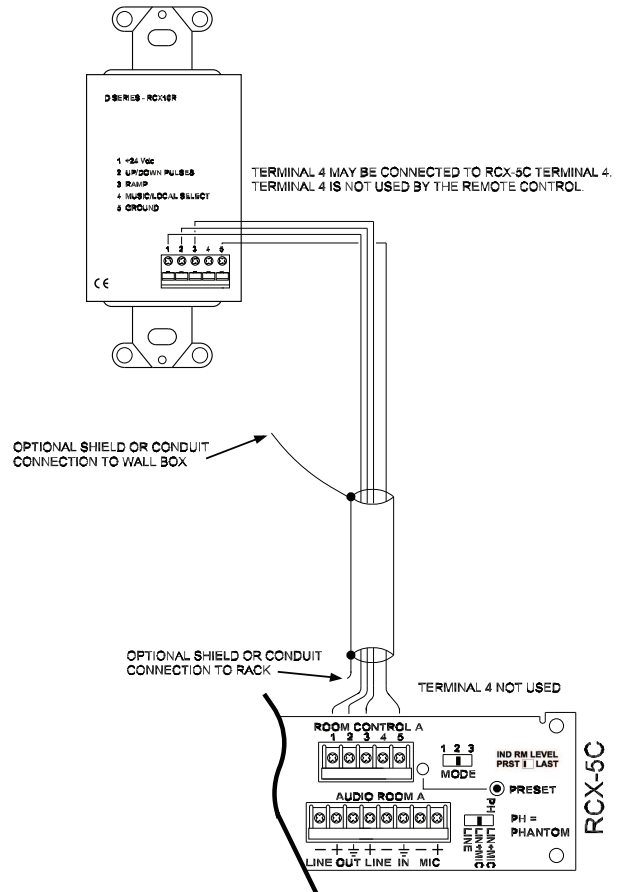
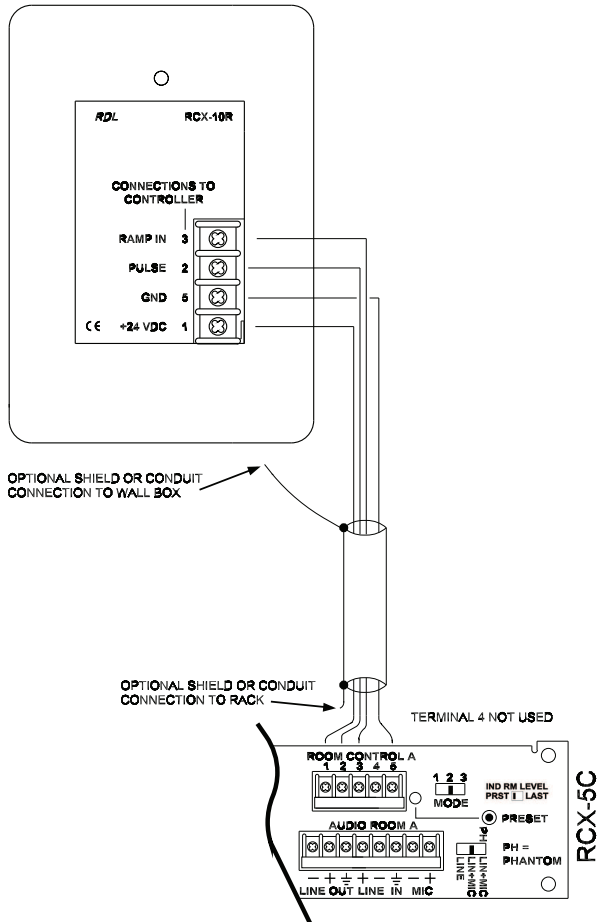

RCX ROOM CONTROL WITH VOLUME ADJUSTMENT ONLY

4.2.4 BACKGROUND MUSIC INPUT WIRING

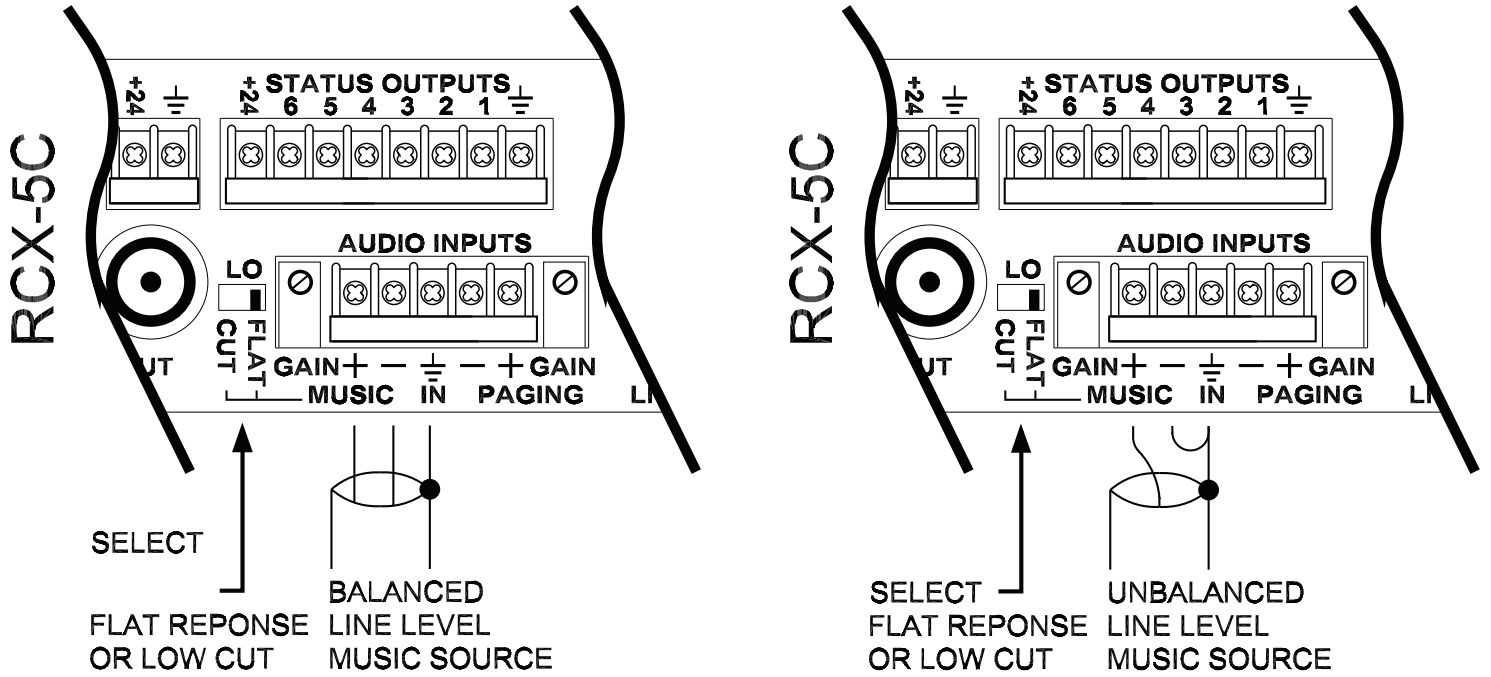

ADJUST INPUT GAIN USING DUAL-LED VU METER ON FRONT PANEL

4.2.5 PAGING INPUT WIRING

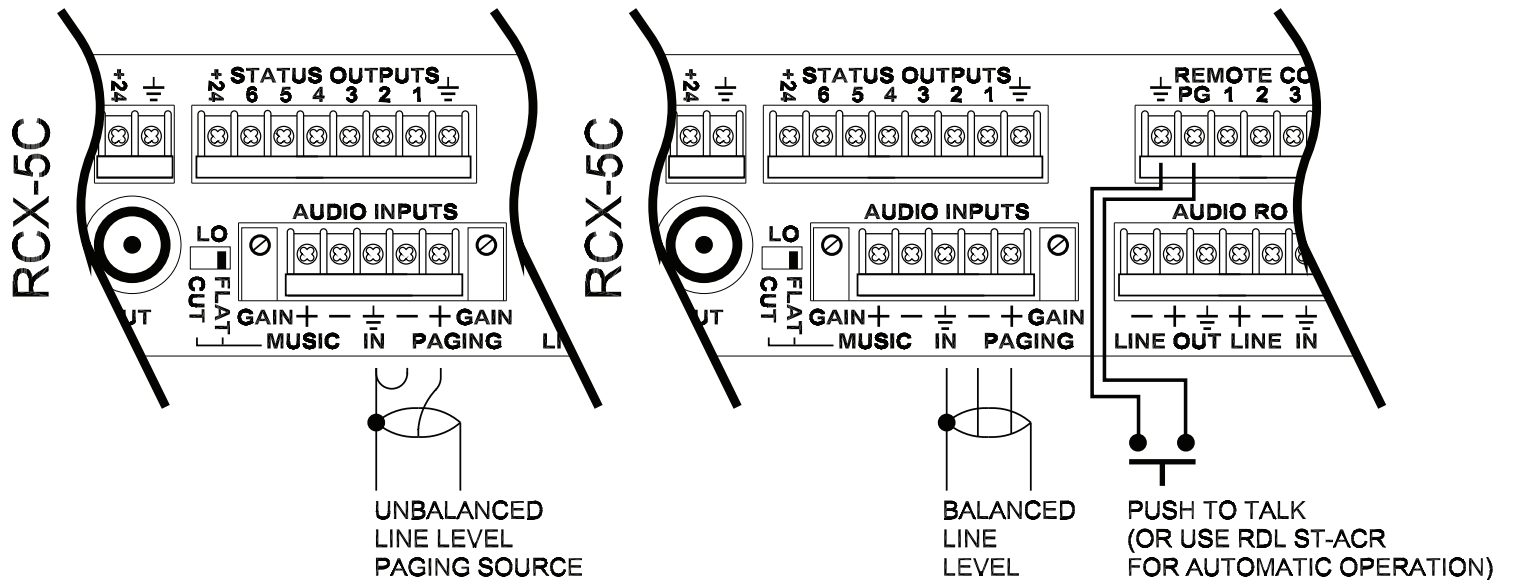

PUSH TO TALK OR OTHER CLOSURE IS REQUIRED TO TRIGGER PAGING

4.2.6 CONNECTING AUXILIARY CONTROLS AND PRODUCTS

RELAY SHOWN WILL BE CLOSED WHEN WALL 1 IS OPEN (ADJACENT ROOMS COMBINED)

NOTE: RDL ST-LCR1 OR ST-LCR1H MAY BE USED FOR ADDITIONAL CURRENT OR TO INVERT LOGIC

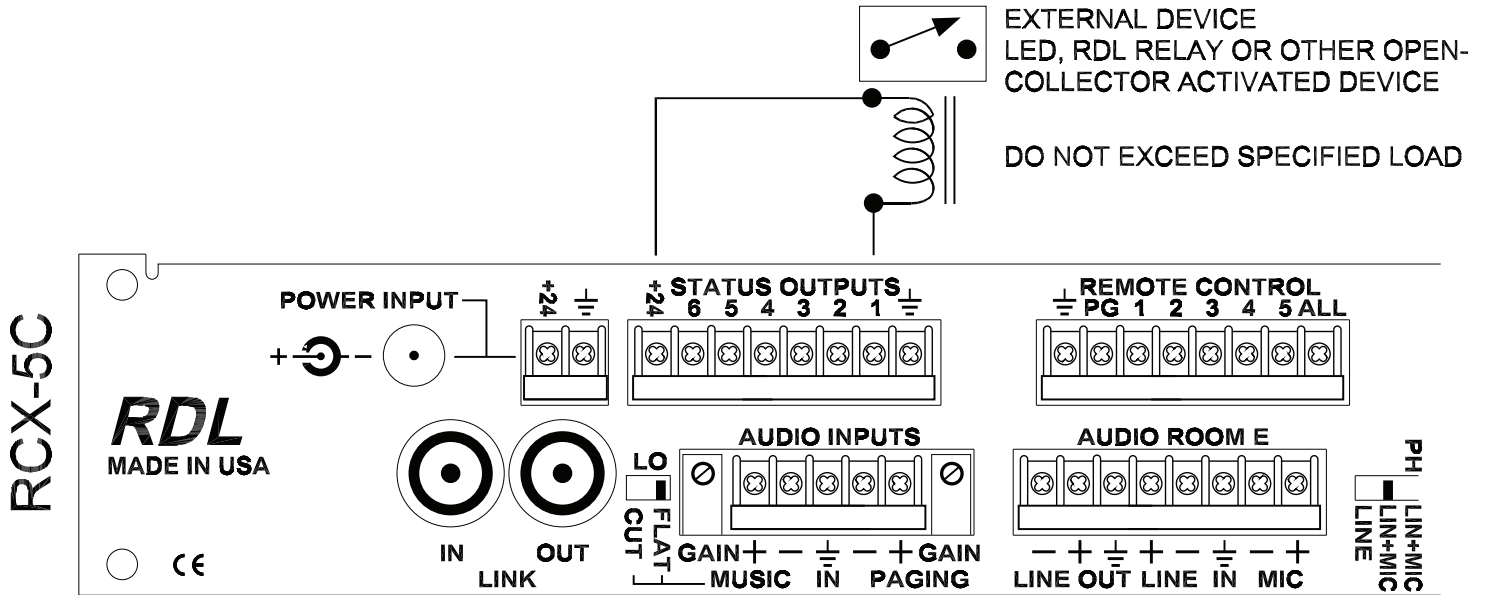

SELECTED ROOM COMBINATIONS ARE USED TO CONTROL OTHER EQUIPMENT (Load ≤ 15 mA)

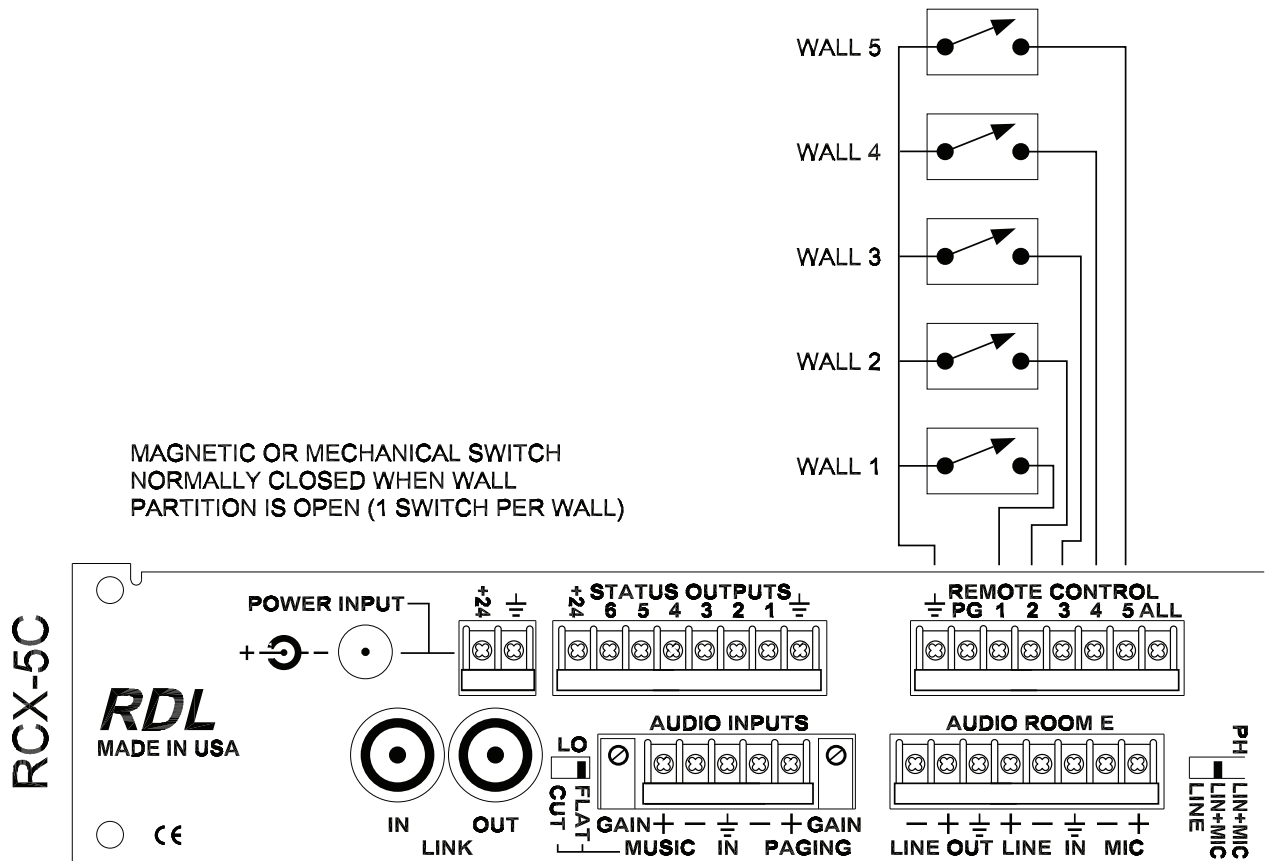

ROOM COMBINATIONS ARE SELECTED USING EXTERNAL SWITCHES

4.2.7 RCX-CD1 CUSTOM CONTROL PANEL

RDL offers RCX-CD1 customized control panels to match any possible room layout. The interface between any RCX-CD1 and the host RCX-5C is identical. Fifteen conductors provide a complete interconnection. Paired cables (such as Cat 5) or unpaired control cable may be used. Multiple RCX-CD1(L)s may be connected simultaneously to the RCX-5C rear terminals. When any RCX-CD1 is used, the RCX-5C **REMOTE CONTROL** input terminals must be set to **MOMENTARY**. (MOMENTARY is the factory default. See Setup Section 3.1.1 for details.)

(Note: Installations using fewer than 5 rooms do not require all 15 conductors. The conductors corresponding to unused front panel switches and LEDs may be omitted. For installation uniformity it may be simpler for the installer to use a standard cable and connect all 15 conductors.)

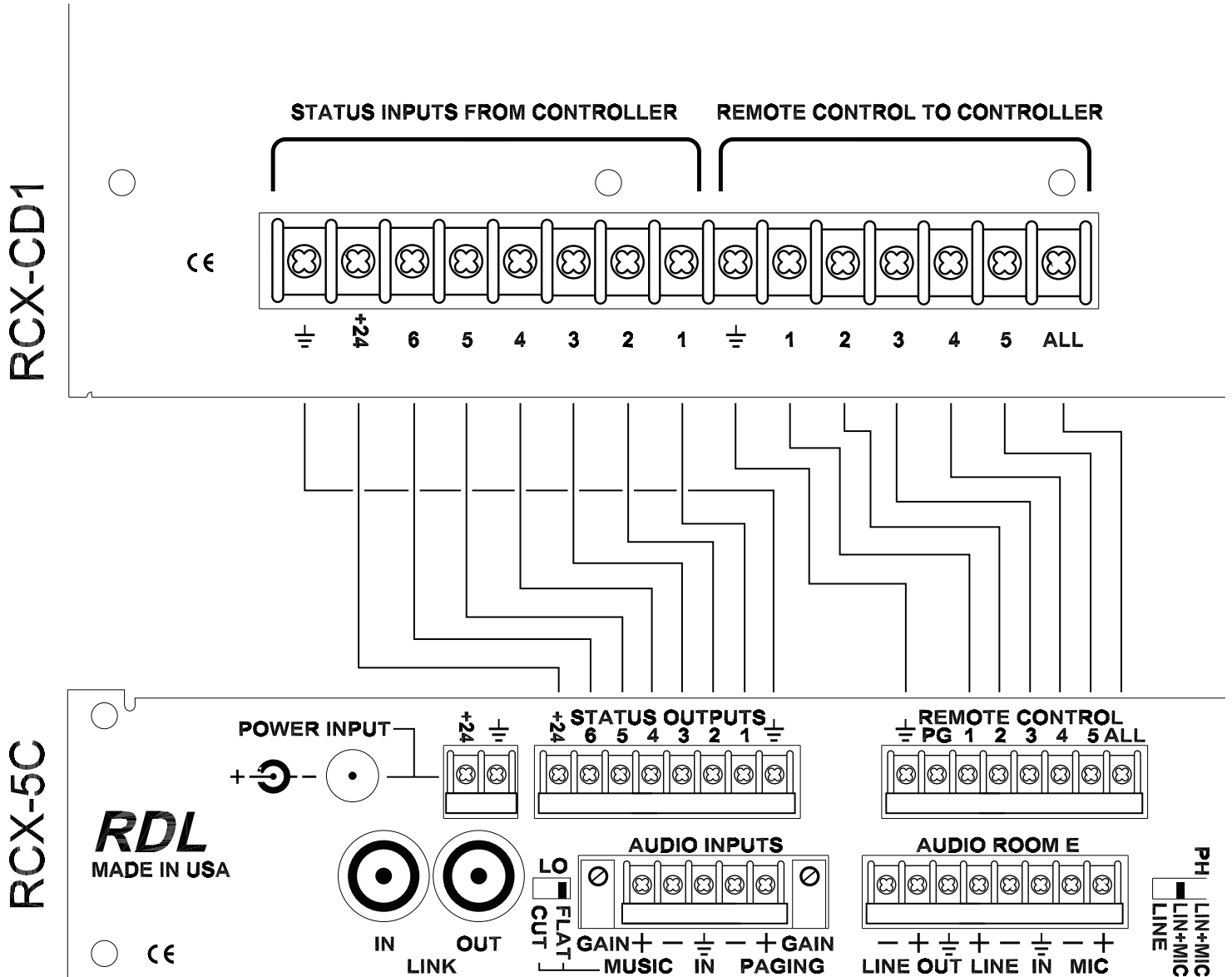

WIRING CONNECTIONS BETWEEN CONTROLLER AND RCX-CD1

5. TYPICAL PERFORMANCE

Audio inputs (12):	2 per room (1 mic and 1 line) 1 Background Music (line-level) 1 Paging (line-level)
Input signal range:	Mic: -20 dBu to -60 dBu Line: -14 dBu to +4 dBu (input selector set to LINE only) Line: -21 dBu to +4 dBu (input selector set to LIN+MIC) Music: -30 dBu to +4 dBu Paging: -30 dBu to +4 dBu
Phantom voltage:	24 Vdc selectable on each input (IEC 1938: 1996-12)
Gain:	Line: Off to 18 dB (front panel adjustable, input selector set to LINE only) Line: Off to 25 dB (front panel adjustable, input selector set to LIN+MIC) Mic: Off to 65 dB
Frequency response:	Line: 15 Hz to 20 kHz (+/- 0.5 dB) Mic: 120 Hz to 20 kHz (+/- 0.75 dB; integral low-cut filter -3 dB @ 75 Hz) Music: 10 Hz to 18 kHz (+/-0.5 dB, filter FLAT) -3 dB @ 50 Hz, -18 dB @ 20 Hz (LO-CUT) Paging: 20 Hz to 7.5 kHz (+/-1.5 dB)
Headroom:	18 dB
Noise (below +4 dBu out):	<-80 dB (line input, local mode, uncombined) <-70 dB (mic input, local mode, uncombined, 60 dB gain) <-75 dB (music mode)
THD+N:	<0.025% (line inputs) ; <0.1% (mic inputs)
Meters (6):	Front panel dual-LED VU metering for music (1) and room (5) inputs
Status outputs (6):	15 mA open collector (internal 24 V pullup; voltage drop 4 Vdc @15 mA) Remote power terminal protected by automatically resetting fuse
Remote control inputs (7):	6 for room combinations, 1 for paging Requires external pull to ground to activate (internal 24 V, 10 kΩ pullup)
Ramp rate (audio level):	3 seconds for full adjustment (RCX-1, D-RCX1, RCX-3) Follows knob rotation (RCX-2, D-RCX2, RCX-10R, D-RCX10R)
Room Control range:	36 dB + Off
Power requirement:	24 Vdc @ 2 A

NOTE: This equipment has been tested and found to comply with the limits for a Class B digital device, pursuant to part 15 of the FCC Rule. These limits are designed to provide reasonable protection against harmful interference in a residential installation. The equipment generates, uses and can radiate radio frequency energy and, if not installed and used in accordance with the instructions, may cause harmful interference to radio communications. However, there is no guarantee that interference will not occur in a particular installation. If this equipment does cause harmful interference to radio or television reception, which can be determined by turning the equipment off and on, the user is encouraged to try to correct the interference by one or more of the following measures:

- Reorient or relocate the receiving antenna
- Increase the separation between the equipment and receiver
- Connect the equipment into an outlet on a circuit different from that which the receiver is connected.
- Consult the dealer or an experienced radio/TV technician for help.

RDL, Radio Design Labs, the Radio Design Labs logo, STICK-ON, Rack-Up and the Rack-Up logo are registered trademarks of Radio Design Labs, Inc. RCX, ULTRASTYLE, TX, Flat-Pak, SourceFlex, Sure-Lok and Specialists in Practical Precision Engineering are trademarks of Radio Design Labs, Inc. All other trademarks are the property of their respective owners. Typical Performance reflects product at publication time exclusive of EMC data, if any, supplied with product.

6. MOUNTING DIMENSIONS

CHASSIS BACKBOX MOUNTING CLEARANCES

RCX-1, RCX-2, RCX-3

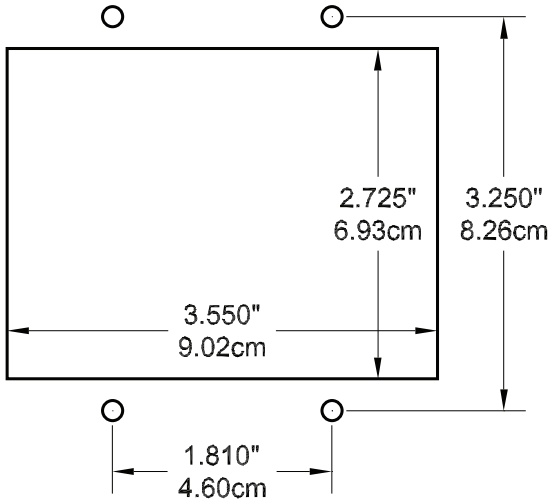

RCX-10R

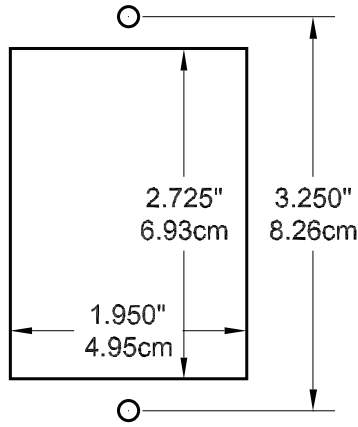

RCX-J1, RCX-J2, RCX-J3,
RCX-A2, D-J1, D-J2, D-J3, D-A2,
D-RCX1, D-RCX2, D-RCX10R

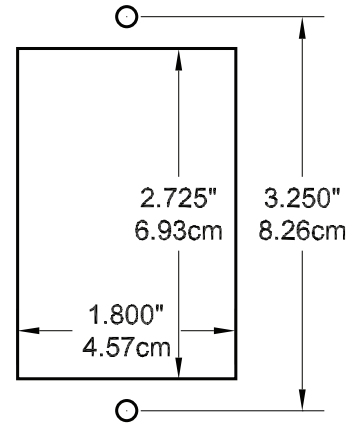

RCX-1,2 DEPTH REQUIREMENT - 1.500" (3.81cm)
RCX-3 DEPTH REQUIREMENT - 1.900" (4.83cm)

RCX-10R, RCX-J1, RCX-J3, RCX-A2
DEPTH REQUIREMENT - 1.500" (3.81cm)

MODELS WITH "D-" PREFIX
DEPTH REQUIREMENT - 1.75" (4.45 cm)

ULTRASTYLE PANEL MOUNTING DIMENSIONS

RCX-1, RCX-2, RCX-3

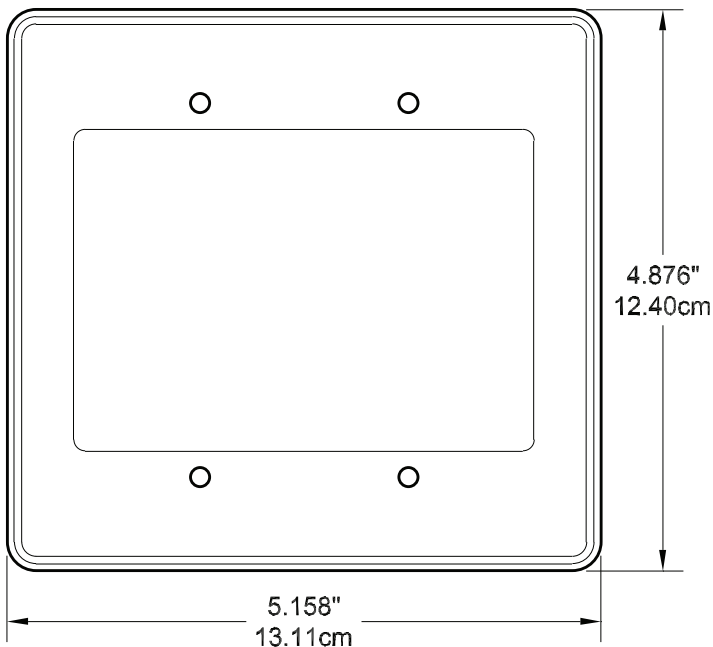

RCX-10R, RCX-J1,
RCX-J3, RCX-A2

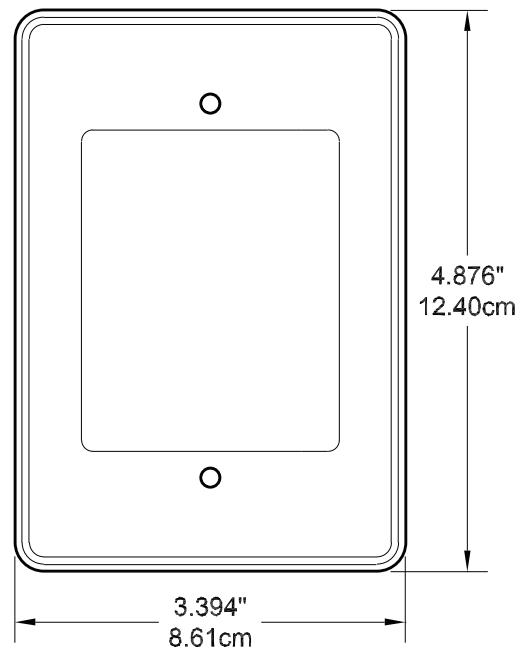

D-SERIES PANELS: Products with "D" prefix fit standard OEM or RDL Decora® plates.