

# 130 Watt Industrial

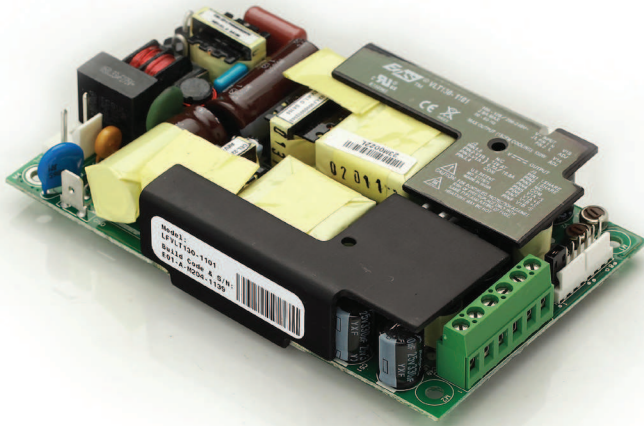

## Features

- 130 W fan cooled rating
- Smallest 130 W AC/DC power supply
- Small 5.0 x 3.14 x 1.025 inches form factor
- Dual channel output
- EN61000-3-2 class A harmonics
- EN55022 and FCC Part15 Level B
- Cover kit accessory available

## Electrical Specifications

AC Input	90-132 V & 180-264 V, Auto Ranging	
Input Frequency	47-63 Hz	
Input Current	120 VAC: 2.2 A max.	230 VAC: 1.2 A max.
Inrush Current	120 VAC: 20 A max.	230 VAC: 40 A max.
Leakage Current	120 VAC: < 500 $\mu$ A	230 VAC: < 1000 $\mu$ A
Efficiency	120 VAC: 82% typical	230 VAC: 85% typical
Hold-up Time	120 VAC: 10 ms	230 VAC: 10 ms
Output Power <sup>4,5</sup>	80 to 130 W	
Line Regulation	+/-0.3%	
Load Regulation	V1 & V2: +/-1%, V3 & V4: +/-5%	
Transient Response	< 10%, 50% to 100% load change, 50/60 Hz, 50% duty cycle, 0.1 A/ $\mu$ s, recovery time < 5 ms	
Rise Time	< 10 ms	
Set Point Tolerance	V1 & V2: +/-1%, V3 & V4: +/-5%	
Over Current Protection	120 to 175%	
Over Voltage Protection	115 to 135%; 115 to 155% for 3.3 V	
Short Circuit Protection	Short term, auto recovery	
Switching Frequency	PFC converter: 90 kHz typical Resonant converter: 55 kHz typical	
Operating Temperature	0 to 50°C	
Storage Temperature	-40 to +85°C	
Relative Humidity	95% Rh, non condensing	
Altitude	Operating: 10,000 ft.; Non-operating: 40,000 ft.	
MTBF	> 150 kh, Bellcore TR332	
Isolation Voltage	Min. 4242 VDC between input to output	
Cooling	Convection: 80 W; 15 CFM: 130 W	
Redundancy	1+1	
Paralleling Function	No	

Model Number	Voltage	Max. Load <sup>1</sup> (Convection)	Max. Load <sup>1</sup> (15 CFM)	Min. Load	Ripple <sup>2</sup>
LFVLT130-1106	V1=3.3 V	20.0 A	32.0 A	3.0 A	1.5%
LFVLT130-1100	V1=5.1 V	16.0 A	25.5 A	3.0 A	1%
LFVLT130-1101	V1=12 V	6.6 A	10.8 A	0.5 A	1%
LFVLT130-1102	V1=15 V	5.4 A	8.7 A	0.5 A	1%
LFVLT130-1103	V1=24 V	3.3 A	5.4 A	0.5 A	1%
LFVLT130-1104	V1=48 V	1.7 A	2.7 A	0.5 A	1%
LFVLT130-4100	V1=5.1 V, V2=3.3 V, V3=12.7 V, V4=-12.4 V	V1=10.0 A, V2=10.0 A, V3=1.0 A, V4=1.0 A	V1=14.0 A, V2=16.0 A, V3=1.5 A, V4=1.5 A	V1, V2=0.5 A, V3, V4=0.1 A	V1, V3, V4=1%, V2=1.5%
LFVLT130-4101	V1=5.1 V, V2=3.3 V, V3=24 V, V4=-12.0 V	V1=10.0 A, V2=10.0 A, V3=1.0 A, V4=1.0 A	V1=14.0 A, V2=16.0 A, V3=1.5 A, V4=1.5 A	V1, V2=0.5 A, V3, V4=0.1 A	V1, V3, V4=1%, V2=1.5%
LFVLT130-4102	V1=5.1 V, V2=3.3 V, V3=16.3 V, V4=-16.3 V	V1=10.0 A, V2=10.0 A, V3=1.0 A, V4=1.0 A	V1=14.0 A, V2=16.0 A, V3=1.5 A, V4=1.5 A	V1, V2=0.5 A, V3, V4=0.1 A	V1, V3, V4=1%, V2=1.5%
LFVLT80-CK metal cover kit accessory					

Connectors		
J1	Pin 1	AC NEUTRAL
	Pin 2	AC LINE
Spade Connector		EARTH
J2	Pin 1	V3
	Pin 2	V2/V1B
	Pin 3, 4	RTN
	Pin 5	V1/V1A
	Pin 6	V4

Connectors		
J3	Pin 1	V2 CURRENT SHARE/V1A CURRENT SHARE
	Pin 2	V1 CURRENT SHARE/V1B CURRENT SHARE
	Pin 3	POWER FAIL (QUAD O/P ONLY)
	Pin 4	RTN
	Pin 5	-V1/-V1A REMOTE SENSE
	Pin 6	+V1/+V1A REMOTE SENSE
	Pin 7	+V2/+V1B REMOTE SENSE
	Pin 8	-V2/-V1B REMOTE SENSE

## Notes

- Maximum current per output channel. Do not exceed total output power rating.
- Ripple is peak to peak with 20 MHz bandwidth and 10  $\mu$ F (Tantalum capacitor) in parallel with a 0.1  $\mu$ F capacitor at rated line voltage and load ranges.
- Power fail signal and power good signal on quad output models only.
- Quad output models: The output section of the VLT130-4XXX is split into 2 independently regulated channels. Channel A consists of the main output V1 and auxiliary output V4. Channel B consists of the main output V2 and auxiliary output V3. The maximum output power that may be drawn per channel is 45 W with convection cooling or 65 W with fan cooling.
- Single output models: The output section of the VLT130-1XXX is split into 2 independently regulated channels. Channel A consists of main output V1A. Channel B consists of main output V1B. An internal shunt resistor of value 0 Ohms connects both channels of the power supply. In an event whereby this shunt resistor is removed, the maximum output power that may be drawn per channel is 45 W with convection cooling or 65 W with fan cooling.
- The use of remote sense function required 15 CFM airflow.
- Specifications are for nominal input voltage, 25°C and max. load unless otherwise stated.
- Derate output power linearly to 80% from 90 VAC to 80 VAC input.

## Mechanical Specifications

AC Input Connector (J1)	Molex: 26-60-4030 or equivalent Mating: 09-50-3031; Pins: 08-50-0106
EARTH	Molex: 19705-4301 Mating: 190030001
DC Output Connector (J2)	Tyco: 282841-6 or equivalent
Signal Connector (J3)	Molex: 22-23-2081 or equivalent Mating: 22-01-2087; Pins: 08-50-0113
Dimensions	5.0 x 3.14 x 1.025 inches (127.0 x 77.22 x 27.18 mm)
Weight	340 g
<b>EMC</b>	
CE Mark	Complies with LVD Directive
Conducted Emissions	EN55022-B, CISPR22-B, FCC PART15-B, EN50082-1
Static Discharge	EN61000-4-2, Level-3
RF Field Susceptibility	EN61000-4-3, Level-3
Fast Transients/Bursts	EN61000-4-4, Level-3
Radiated Emissions	EN55022-B, CISPR22-B, FCC PART15-B To be controlled in end system
Surge Susceptibility	EN61000-4-5, Level-3
Harmonic Current	EN61000-3-2, Class A
<b>Safety</b>	
Safety Standard(s)	IEC60950-1 (ed.2), UL60950-1 (2nd Edition), Class 1 SELV
Approval Agency	UL, C-UL
Safety File Number(s)	UL: E150565
<b>Signal</b>	
Power Fail Signal <sup>3</sup>	Signal goes low 1 ms advance before output goes out of regulation due to a mains failure
Remote Sense <sup>6</sup>	Compensation for 100 mV on V1 & V2
Power Good <sup>3</sup>	Signal goes high after main output is within regulation band, delay is 30 ms

### Single Output Connection

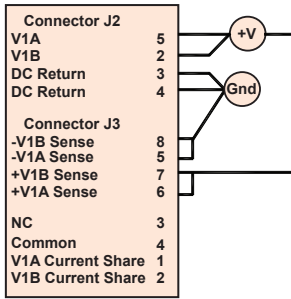

### Quad Output Connection

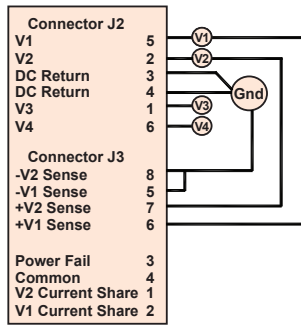

### Single Output 1+1 Redundant Configuration

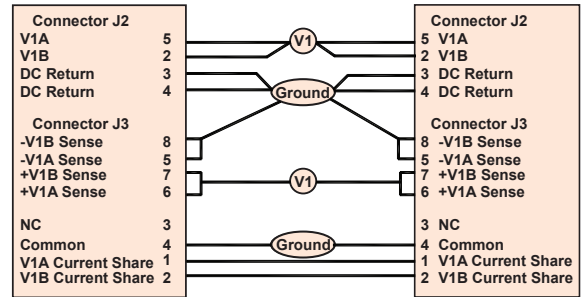

### Quad Output 1+1 Redundant Configuration

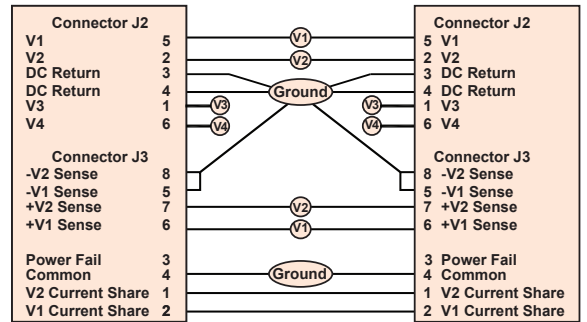

1. To connect the voltage sense pins 5, 6, 7 and 8 on connector J3 to the load, it is recommended to use 22 gauge twisted pair wire.
2. For single output units, an internal 0 Ohm resistor shunt is used to internally connect the current share pins V1B current share (J3-2) and V1A current share (J3-1).
3. Pins J3-4, Common, should be connected to ground for correct operation.
4. The Power fail signal J3-3 is a TTL active high signal. The maximum source current is 0.45 mA and the maximum sink current is 0.25 mA.

## Mechanical Drawing

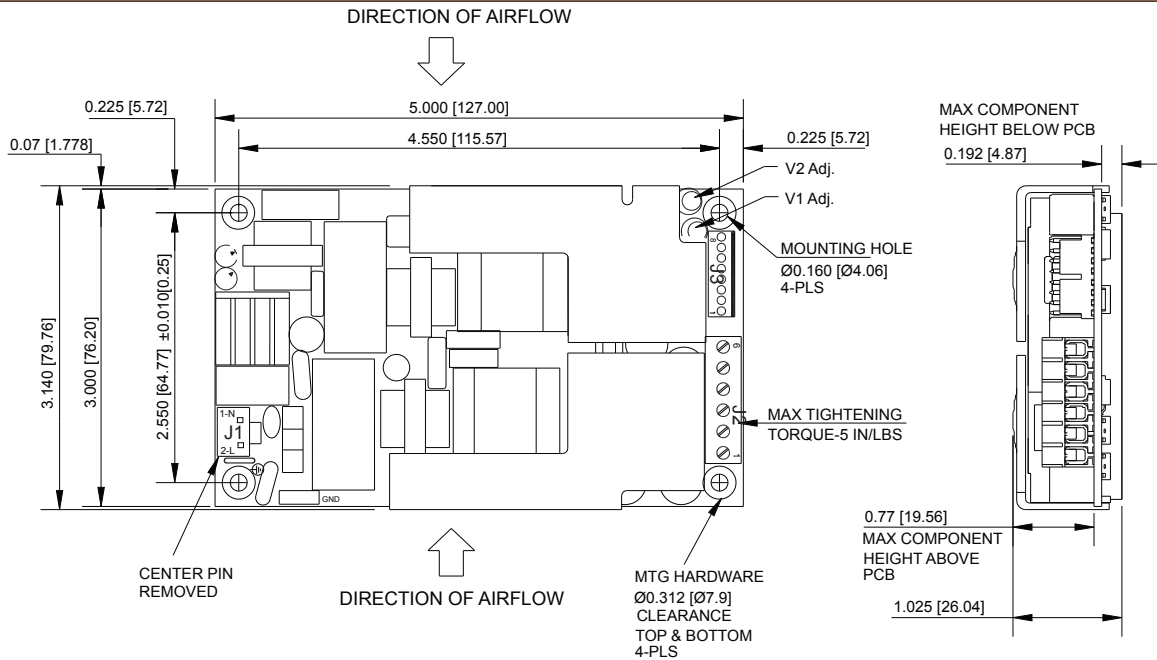

MECHANICAL OUTLINE DIMENSIONS  
ALL DIMENSIONS ARE IN INCHES [MM]  
GEN. TOLERANCE:  $\pm$ 0.02 [ $\pm$ 0.5]