

150 Watt Industrial (VLT)



Features

- 150 W fan cooled rating
- Smallest 150 W AC/DC power supply
- Small 5.0 x 3.14 x 1.025 inches form factor
- Dual channel output
- EN61000-3-2 class A & D harmonics
- EN55022 and FCC Part15 Level B
- Cover kit accessory available

Electrical Specifications

AC Input	90-264 V, Universal	
Input Frequency	47-63 Hz	
Input Current	120 VAC: 1.8 A max.	230 VAC: 0.9 A max.
Inrush Current	120 VAC: Limited to safe value	230 VAC: Limited to safe value
Leakage Current	120 VAC: < 500 μ A	230 VAC: < 1000 μ A
Efficiency	120 VAC: 82% typical	230 VAC: 85% typical
Hold-up Time	120 VAC: 10 ms	230 VAC: 10 ms
Output Power ^{4,5}	80 to 150 W	
Line Regulation	+/-1%	
Load Regulation	V1 & V2: +/-1%, V3 & V4: +/-5%	
Transient Response	< 10%, 50% to 100% load change, 50/60 Hz, 50% duty cycle, 0.1 A/ μ s, recovery time < 5 ms	
Rise Time	< 10 ms	
Set Point Tolerance	V1 & V2: +/-1%, V3 & V4: +/-5%	
Over Current Protection	107 to 150%	
Over Voltage Protection	115 to 135%; 115 to 155% for 3.3 V	
Short Circuit Protection	Short term, auto recovery	
Switching Frequency	PFC converter: 70 kHz typical Resonant converter: 55 kHz typical	
Operating Temperature	0 to 50°C	
Storage Temperature	-40 to +85°C	
Relative Humidity	95% Rh, non condensing	
Altitude	Operating: 10,000 ft.; Non-operating: 40,000 ft.	
MTBF	> 100 kh, Bellcore TR332	
Isolation Voltage	Min. 4242 VDC between input to output	
Cooling	Convection: 80 W; 300 LFM: 150 W	
Redundancy	1+1	
Paralleling Function	No	

Model Number	Voltage	Max. Load ¹ (Convection)	Max. Load ¹ (300 LFM)	Min. Load	Ripple ²
LFVLT150-1106	V1=3.3 V	20.0 A	36.0 A	3.0 A	1.5%
LFVLT150-1100	V1=5.1 V	15.7 A	29.4 A	3.0 A	1%
LFVLT150-1101	V1=12 V	6.7 A	12.5 A	0.5 A	1%
LFVLT150-1103	V1=24 V	3.3 A	6.25 A	0.5 A	1%
LFVLT150-1104	V1=48 V	1.7 A	3.13 A	0.5 A	1%
LFVLT150-4100	V1=5.1 V, V2=3.3 V, V3=13 V, V4=-13.2 V	V1=10.0 A, V2=10.0 A, V3=1.0 A, V4=1.0 A	V1=16.0 A, V2=19.0 A, V3=1.0 A, V4=1.0 A	V1, V2=0.5 A, V3, V4=0.1 A	V2=1.5%, V1, V3, V4=1%
LFVLT150-4101	V1=5.1 V, V2=3.3 V, V3=24 V, V4=-13.2 V	V1=10.0 A, V2=10.0 A, V3=1.5 A, V4=0.5 A	V1=16.0 A, V2=19.0 A, V3=1.0 A, V4=1.0 A	V1, V2=0.5 A, V3, V4=0.1 A	V2=1.5%, V1, V3, V4=1%
LFVLT150-4102	V1=5.1 V, V2=3.3 V, V3=15 V, V4=-15 V	V1=10.0 A, V2=10.0 A, V3=1.0 A, V4=1.0 A	V1=16.0 A, V2=19.0 A, V3=1.5 A, V4=1.5 A	V1, V2=0.5 A, V3, V4=0.1 A	V2=1.5%, V1, V3, V4=1%
LFVLT80-CK metal cover kit accessory					

Connectors		
J1	Pin 1	AC NEUTRAL
	Pin 2	AC LINE
Spade Connector		EARTH
J2	Pin 1	V3
	Pin 2	V2/V1B
	Pin 3, 4	RTN
	Pin 5	V1/V1A
	Pin 6	V4

Connectors		
J3	Pin 1	V2 CURRENT SHARE/V1A CURRENT SHARE
	Pin 2	V1 CURRENT SHARE/V1B CURRENT SHARE
	Pin 3	POWER FAIL (QUAD O/P ONLY)
	Pin 4	RTN
	Pin 5	-V1/-V1A REMOTE SENSE
	Pin 6	+V1/+V1A REMOTE SENSE
	Pin 7	+V2/+V1B REMOTE SENSE
	Pin 8	-V2/-V1B REMOTE SENSE

Notes

1. Maximum current per output channel. Do not exceed total output power rating.
2. Ripple is peak to peak with 20 MHz bandwidth and 10 μ F (Tantalum capacitor) in parallel with a 0.1 μ F capacitor at rated line voltage and load ranges.
3. Power fail signal and power good signal on quad output models only.
4. Quad output models: The output section of the VLT150-4XXX is split into 2 independently regulated channels. Channel A consists of the main output V1 and auxiliary output V4. Channel B consists of the main output V2 and auxiliary output V3. The maximum output power that may be drawn per channel is 55 W with convection cooling or 75 W with fan cooling.
5. Single output models: The output section of the VLT150-1XXX is split into 2 independently regulated channels. Channel A consists of the main output V1A. Channel B consists of the main output V1B. An internal shunt resistor of value 0 Ohms connects both channels of the power supply. In an event whereby this shunt resistor is removed, the maximum output power that may be drawn per channel is 55 W with convection cooling or 75 W with fan cooling.
6. The use of remote sense function required 300 LFM airflow.
7. Specifications are for nominal input voltage, 25°C and max. load unless otherwise stated.
8. Derate output power linearly to 80% from 90 VAC to 80 VAC input.

Mechanical Specifications

AC Input Connector (J1)	Molex: 26-60-4030 or equivalent Mating: 09-50-3031; Pins: 08-50-0106
EARTH	Molex: 19705-4301 Mating: 190030001
DC Output Connector (J2)	Tyco: 282841-6 or equivalent
Signal Connector (J3)	Molex: 22-23-2081 or equivalent Mating: 22-01-2087; Pins: 08-50-0113
Dimensions	5.0 x 3.14 x 1.025 inches (127.0 x 77.22 x 27.18 mm)
Weight	340 g

EMC

CE Mark	Complies with LVD Directive
Conducted Emissions	EN55022-B, CISPR22-B, FCC PART15-B, EN50082-1
Static Discharge	EN61000-4-2, Level-3
RF Field Susceptibility	EN61000-4-3, Level-3
Fast Transients/Bursts	EN61000-4-4, Level-3
Radiated Emissions	EN55022-B, CISPR22-B, FCC PART15-B To be controlled in end system
Surge Susceptibility	EN61000-4-5, Level-3
Harmonic Current	EN61000-3-2, Class A

Safety

Safety Standard(s)	IEC60950-1 (ed.2), EN60950-1, UL60950-1 (2nd Edition), CSA C22.2 No. 60950-1 (2nd Edition), Class 1 SELV
Approval Agency	Nemko, UL, C-UL
Safety File Number(s)	Nemko: 165490 UL: E150565

Signal

Power Fail Signal ³	Signal goes low 1 ms advance before output goes out of regulation due to mains failure
Remote Sense ⁶	Compensation for 100 mV on V1 & V2
Power Good ³	Signal goes high after main output is within regulation band, delay is 30 ms

Single Output Connection

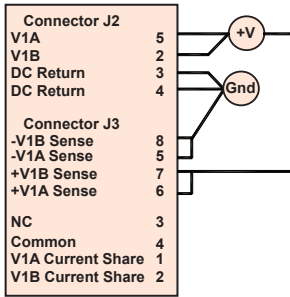

Quad Output Connection

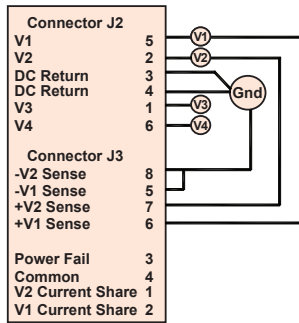

Single Output 1+1 Redundant Configuration

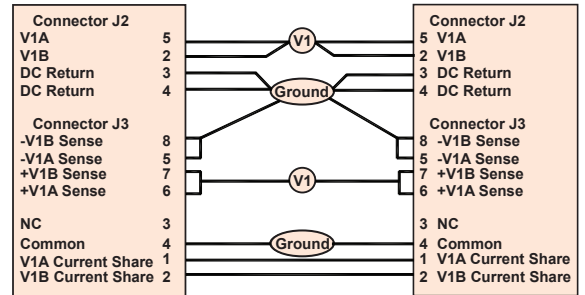

Quad Output 1+1 Redundant Configuration

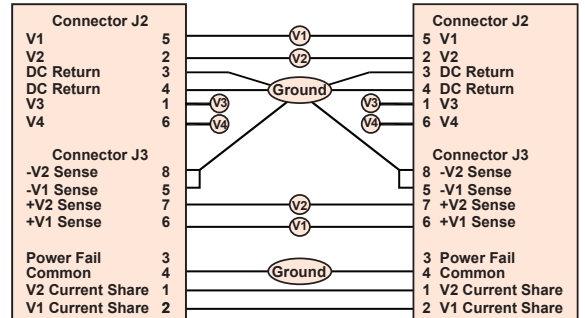

1. To connect the voltage sense pins 5, 6, 7 and 8 on connector J3 to the load, it is recommended to use 22 gauge twisted pair wire.
2. For single output units, an internal 0 Ohm resistor shunt is used to internally connect the current share pins V1B current share (J2-2) and V1A current share (J3-1).
3. Pins J3-4, Common, should be connected to ground for correct operation.
4. The Power fail signal J3-3 is a TTL active high signal. The maximum source current is 0.45 mA and the maximum sink current is 0.25 mA.

Mechanical Drawing

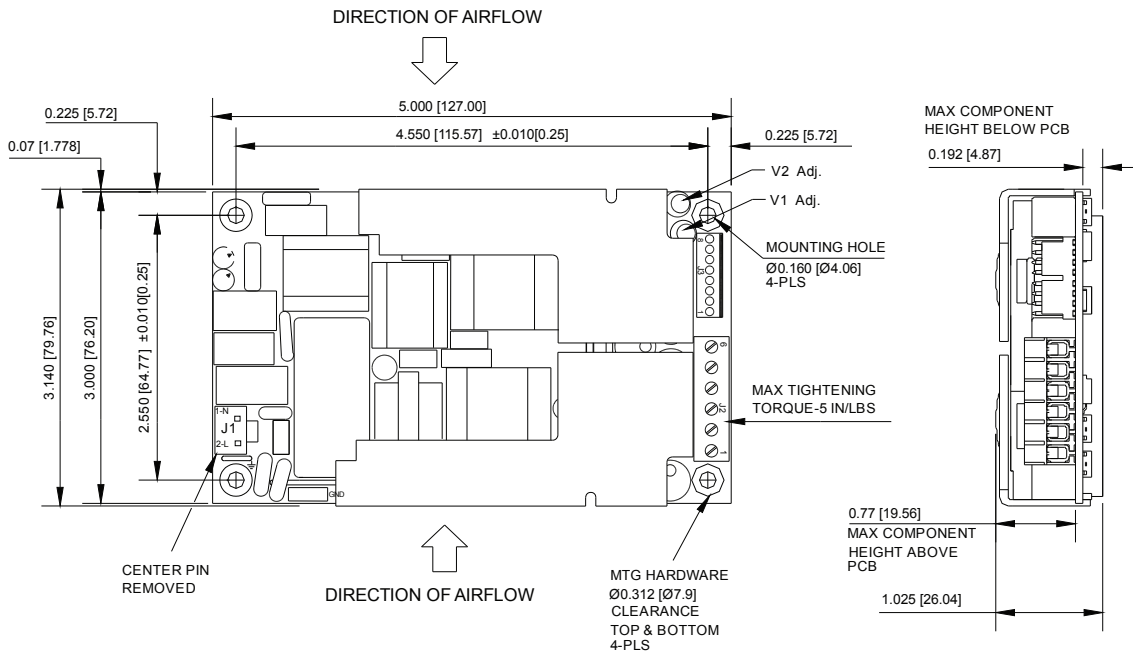

MECHANICAL OUTLINE DIMENSIONS
ALL DIMENSIONS ARE IN INCHES [MM]
GEN. TOLERANCE: +/-0.02 [+/-0.5]