



## 19.6W Power over Ethernet Adapter DC Input Single Port Injector



### Features

- Detection and Classification per IEEE802.3af
- Diagnostic LEDs
- Non-Vented Case
- DC Input Voltage 18-72VDC
- 1 Year Warranty
- UNH IOL Tested
- Full Protection OCP, OVP
- Gigabit Compatible
- Lowest cost DC Input Power Injector

### Applications

- IP Telephones
- Wireless Network Access Points
- Blue Tooth Access Point
- Security Cameras
- IP Print Servers

### Safety Approvals

- CE±

### Mechanical Characteristics

- Length: 140mm (5.51in)
- Width: 65mm (2.55in)
- Height: 36mm (1.42in)
- Weight: 0.2Kg (0.44lb.)

### Output Specifications

Model	DC Output Voltage	Load		Regulation	
		Min.	Max.	Line	Load
POE20D-1AF	56V	0A	0.35A	54-57Vdc under all conditions	

Phihong is not responsible for any error, and reserves the right to make changes without notice. Please visit our website at [www.phihong.com](http://www.phihong.com) for the most up-to-date specifications and contact information.

**INPUT:**

**DC Input Voltage Range**  
18 to 72VDC

**DC Input Current**

1.5A for 18V DC and maximum load

**OUTPUT:**

**Total Output Power**  
19.6W at 56VDC

**DC Offset**

No data degradation with DC imbalance 18mA

**Efficiency**

80% at maximum load (>36 to 72VDC)  
75% at maximum load(18 to <36VDC)

**Ripple and Regulation**

100mV maximum at ambient 25°C

**Transient O/P Voltage Protection**

60V maximum at switch on and off

**ENVIRONMENTAL:**

**Temperature**

Operation -20 to +50°C  
Non-operation -25 to +85°C

**Humidity**

Operation 5 to 90%

**EMC**

FCC Part 15 Class B  
EN55022 Class B

**Isolation Test**

Primary to Secondary: 2121VDC for 1 minute, 10mA  
Primary to Field Ground: 2121VDC for 1 minute, 10mA  
Output to Field Ground: 2121VDC for 1 minute, 10mA

**Immunity**

ESD: EN61000-4-2. Level 3  
RS: EN61000-4-3. Level 3  
EFT: EN61000-4-4. Level 2  
Surge: EN61000-4-5. Level 3  
CS: EN61000-4-6. Level 3  
Voltage Dips EN61000-4-11  
Harmonic: EN61000-3-2

**Insulation Resistance**

Primary to Secondary: >10M OHM 500VDC  
Primary to Field Ground: >10M OHM 500VDC

**FEATURE:**

**Over Voltage/Current, Short Circuit Protection**

Outputs equipped with short circuit protection and overload protection as per 802.3af specification  
The output can be shorted permanently without damage

**Indicators**

Green LED 1: Input power “ON”  
Red LED: Fault detected  
Green LED 2: Valid IEEE802.3af load detected and connected

**Input Connector**

– Anytek OQ0355510000G  
Mate – Anytek TJ0350520000G or TJ035152000G  
Anytek is part of Giga-Way Technology Corp

**Output Connection**

+pins 3, 6  
-pins 1, 2

**Warranty**

1 Year

**Dimension Diagram Unit: mm (inch)**

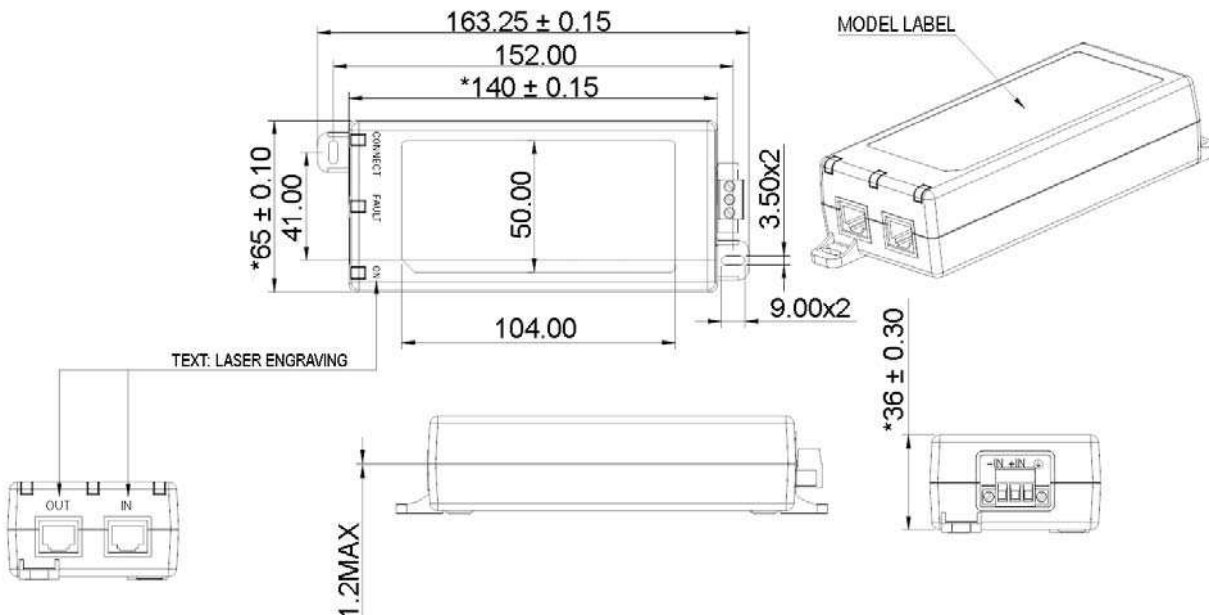



## Gigabit Power Injector Block Diagram

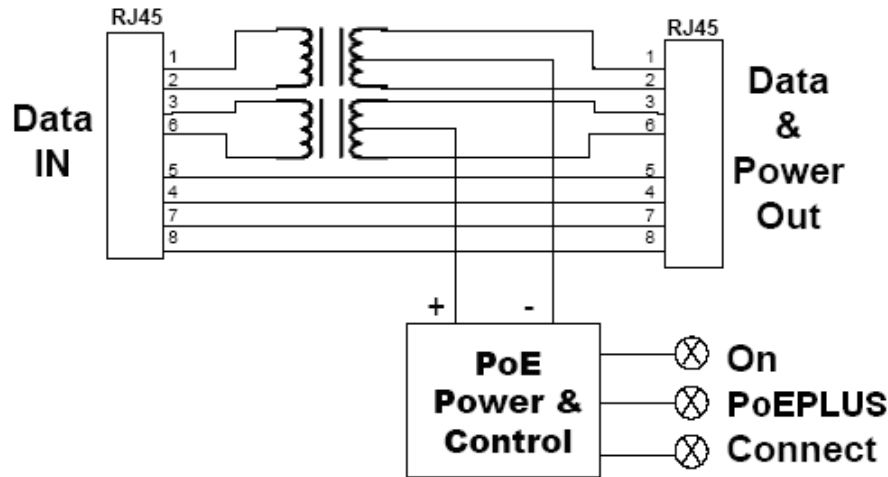

---

### Description of LED Functions for Gigabit Power Injector

#### Power-up Sequence:

Upon power-up, all 3 LEDs will light for 2 seconds, as part of the self-test for the internal microprocessor software. After the end of the 2 seconds, the "ON" LED will illuminate green, signifying that the DC output voltage is available for powering a compliant load (to the 802.3af PoE standards).

#### Detection Sequence:

Once a compliant load is attached to the output RJ45 connector, the green "CONNECT" LED will illuminate.

Should the load be non-compliant then the LEDs will blink a code signifying the cause for non-detection.

#### Detection Failure Codes:

1. Incorrect resistive signature – The green "CONNECT" and red "FAULT" LEDs will blink 3 times.
2. Incorrect capacitive signature – The green "ON" LED will blink 3 times.
3. Incorrect Voffset – The green "CONNECT" and green "ON" LEDs will blink 3 times.
4. Unstable current measurement – The green "ON" LED will blink 3 times
5. Low voltage sensed during detection (overload) – The red "FAULT" LED will blink 3 times

After the LEDs blink 3 times the Power Injector will continue to try to detect a valid load. Therefore, until the correct load is applied, the LEDs will continue to blink. If there is an open circuit connected to the output RJ45 then the LEDs will not blink but the Power Injector will continue to try to detect a valid load.

#### Fault Sequence:

Should there be a fault such as an overload or short circuit then the red "FAULT" LED will illuminate. The red "FAULT" LED will illuminate for 2 seconds and then go off as the power supply tries to redetect a valid load. If there is a problem in detecting, the LED will indicate what is wrong with the load as per the codes in the section above.