



33.6W Power over Ethernet Adapter High Power Single Port Injector



Features

- Compliant with the IEEE802.3at Standard
- Diagnostic LEDs
- Gigabit Compatible
- Cisco AP1250 Full Power Support
- UNH IOL Tested
- Non-Vented Case
- Full Protection OCP, OVP
- 1 Year Warranty

Applications

- IP Telephones
- Wireless Network Access Points
- Blue Tooth Access Point
- Security Cameras with Pan/Tilt/Zoom
- IP Print Servers

Safety Approvals

- CE
- C-Tick
- cUL/US
- SAA

Mechanical Characteristics

- Length: 140mm (5.51in)
- Width: 65mm (2.55in)
- Height: 36mm (1.42in)
- Weight: 0.2Kg (0.44lb.)

Output Specifications

Model	DC Output Voltage	Load		Regulation	
		Min.	Max.	Line	Load
POE36U-1AT	56V	0A	0.60A	54-57Vdc under all conditions	

Phihong is not responsible for any error, and reserves the right to make changes without notice. Please visit our website at www.phihong.com for the most up-to-date specifications and contact information.

INPUT:

AC Input Voltage Range
90 to 264VAC

AC Input Voltage Rating
100 to 240VAC

AC Input Current
1.0A (RMS) and 90VAC at maximum load
.55A (RMS) and 240VAC at maximum load

AC Input Frequency
47 to 63Hz

OUTPUT:

Total Output Power
33.6W

DC Offset
No Data degradation with DC imbalance 18mA

Ripple and Regulation
100mV maximum

Efficiency
78% (typical) at maximum load, and 120VAC 60Hz

Transient O/P Voltage Protection
60V maximum at switch on and off at any AC line phase

ENVIRONMENTAL:

Temperature
Operation -20 to +50°C
Non-operation -20 to +65°C

Humidity
Operation 5 to 90%

EMC
FCC Part 15 Class B
EN55022 Class B

Isolation Test
Primary to Secondary: 4242 VDC for 1 minute 10mA
Primary to Field Ground: 2121VDC for 1 minute
Output to Field Ground: 2121VDC

Immunity

ESD: EN61000-4-2. Level 3
RS: EN61000-4-3. Level 2
EFT: EN61000-4-4. Level 2
Surge: EN61000-4-5. Level 3
CS: EN61000-4-6. Level 2
Voltage Dips EN61000-4-11
Harmonic: EN61000-3-2

Insulation Resistance

Primary to Secondary: >10M OHM 500VDC
Primary to Field Ground: >10M OHM 500VDC

FEATURE:

Cisco

No extern parts required for Legacy devices:
VoIP Phones:
7910, 7912, 7940, 7960
Access Points:
1040, 1140, 1250, 1260, 3500

Over Voltage/Current, Short Circuit Protection

Outputs equipped with short circuit protection and overload protection as per 802.3at specification
The output can be shorted permanently without damage

Indicators

Green LED 1: Input power “ON”
Green LED 2: Valid IEEE802.3at load detected and connected “PoE PLUS”
Green LED 3: Valid IEEE802.3af load detected and connected

Input Connector

IEC320 3 pin

Output Connection

+pins 3, 6
-pins 1, 2

Warranty

1 Year

Dimension Diagram Unit: mm (inch)

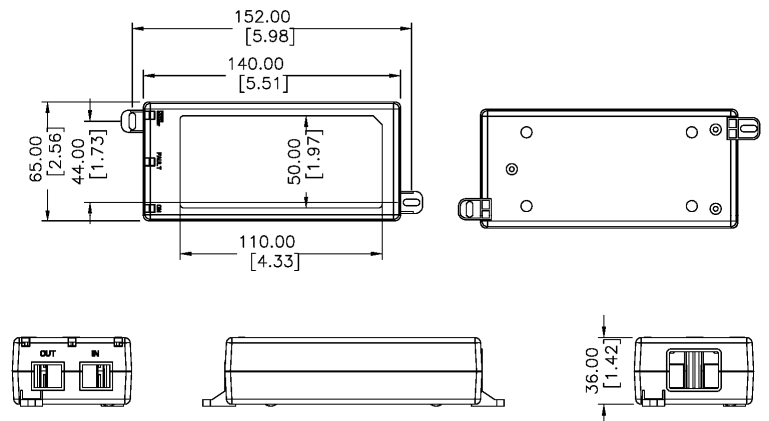



Gigabit Power Injector Block Diagram

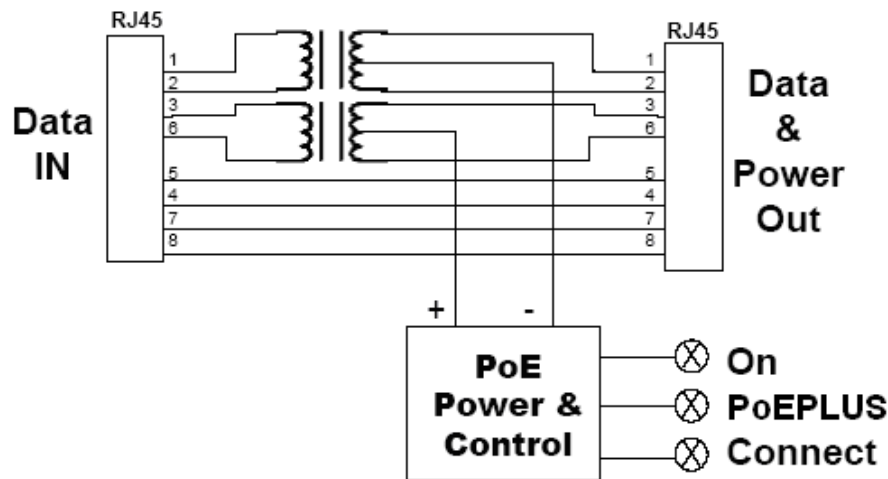

Description of LED Functions for Gigabit Power Injector

Power-up Sequence:

Upon power-up, all 3 LEDs will light for 2 seconds, as part of the self-test for the internal microprocessor software. After the end of the 2 seconds, the "ON" LED will illuminate green, signifying that the DC output voltage is available for powering a compliant load (to the 802.3at PoE standards).

Detection Sequence:

Once a compliant load is attached to the output RJ45 connector, the green "CONNECT" LED will illuminate. Should the load is classified as Class 4 PD, the green "PoEPLUS" LED will illuminate. Otherwise, "PoEPLUS" LED will stay off. Should the load be non-compliant then the LEDs will blink a code signifying the cause for non-detection.

Detection Failure Codes:

1. Incorrect resistive signature – The green "CONNECT" and green "PoEPLUS" LEDs will blink 3 times.
2. Incorrect capacitive signature – The green "ON" LED will blink 3 times.
3. Incorrect Voffset – The green "CONNECT" and green "ON" LEDs will blink 3 times.
4. Unstable current measurement – The green "CONNECT" LED will blink 3 times
5. Low voltage sensed during detection (overload) – The green "PoE PLUS" LED will blink 3 times

After the LEDs blink 3 times the PSE will continue to try to detect a valid load. Therefore, until the correct load is applied, the LEDs will continue to blink. If there is an open circuit connected to the output RJ45 then the LEDs will not blink but the PSE will continue to try to detect a valid load.

Fault Sequence:

Should there be a fault such as an overload or short circuit then all the three LEDs will blink 5 times in 2 seconds, and then go off as the power supply tries to re-detect a valid load. If there is a problem in detecting, the LED will indicate what is wrong with the load as per the codes in the section above.