

# PXES-2780

18-Slot 3U PXI Express Chassis with AC – Up to 8 GB/s



## Introduction

The ADLINK PXES-2780 is an 18-slot PXI Express chassis, compliant with PXI Express and cPCI Express specifications and offering one system slot, one system timing slot, ten hybrid peripheral slots, and six PXI Express peripheral slots for a wide variety of testing and measurement applications requiring enhanced bandwidth. The PXES-2780 provides a configurable PCIe switch fabric and is configurable in two-link, and four-link PXI express deployments, with 8 GB/s system bandwidth and up to 4 GB/s slot bandwidth for dedicated peripheral slots, thanks to PCIe gen2 signaling technology.

The PXES-2780 implements a smart system monitoring controller, reporting full chassis status, including fan speed, system voltages, and internal temperature.

Equipped with an industrial grade AC power supply, the PXES-2780 provides 800 W under 55°C, and superior cooling capacity, from three 120 mm fans on the rear of the chassis, and two BNC connectors for 10 MHz clock input/output on the rear panel increase chassis flexibility, enabling synchronization with supplementary devices. All in all, PXES-2780 is a superior PXI Express platform choice for testing and measurement requirements.

## Features

- PXI™-5 PXI Express hardware specification Rev.1.0 compliant
- 18-slot PXI Express chassis with one system slot, one system timing slot, 10 hybrid peripheral slots, and 6 PXI Express peripheral slots
- Configurable PCIe switch fabric, can be configured as four-link, two-link, PXI Express chassis
- Up to 8 GB/s system bandwidth
- Up to 4 GB/s peripheral bandwidth for dedicated slots
- 0°C to 55°C extended operating temperature range
- Intelligent chassis management
  - Automatic fan speed control
  - Chassis status monitoring and reporting
  - Remote chassis power on/off control
- BNC connectors for 10 MHz clock input/output
- Maximum total usable power of 800 W under 55°C
- Power, temperature, and fan monitoring LEDs

PXES-2780 Front View

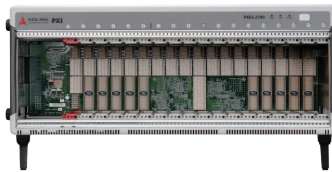
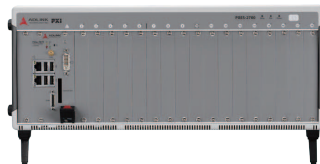

PXES-2780 Hybrid Peripheral Slots

PXES-2780 Back View



10 MHz Ref clock input/output BNC connectors

FAN Speed Control Switch

Remote Monitoring Port

Inhibit Enable/Disable Switch & Power rails monitoring port

## Highlights

### Configurable PCIe Switch Fabric

The PXES-2780 provides a configurable PCIe switch fabric and is configurable in two-link x8, and four-link x4 PXI express deployments, allowing users to fully utilize the PCIe gen2 bandwidth for high-bandwidth applications.

### Hybrid Peripheral Slot Design

The ADLINK PXES-2780 features 10 hybrid peripheral slots, with PXI Express, cPCI Express, PXI, and CompactPCI modules compatible with every hybrid slot.

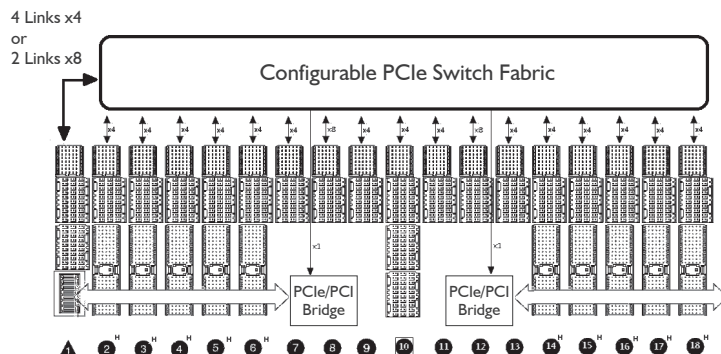

**Intelligent Chassis Management**

The PXES-2780's built-in system monitoring controller monitors and manages full chassis status, including internal temperature, fan speed, and DC voltages, with monitored data accessible with the embedded controller or remote PC via standard RS-232 connector.

**Innovative Cooling**

The ADLINK PXES-2780 features an innovative heat dissipation solution, with three 185.9CFM cooling fans in the rear section of the chassis drawing cool air through lower apertures, then exhausting through the back. This design normalizes airflow for each PXI slot, delivering exceptional cooling. When installed in a rack, the cooling design minimizes intake of hot air from the rear side, separating airflow for modules and power supplies, while isolating source (fan) noise from modules and maintaining a steady internal temperature.

**Notes:**

1. ADLINK's PXI Express chassis accepts hybrid slot-compatible PXI-5 modules (with XJ4 connector). Legacy PXI-I boards (with J2 connector) need to be upgraded to hybrid slot-compatible PXI modules. A detailed list of ADLINK PXI hybrid slot-compatible modules is available online at: <http://www.adlinktech.com/PXI/pxi-breakthrough-bandwidth.php#FAQ>

2. Contact your ADLINK sales representative for assistance in upgrading ADLINK legacy PXI modules. If the PXI modules were purchased from a third party, please contact the original vendor.

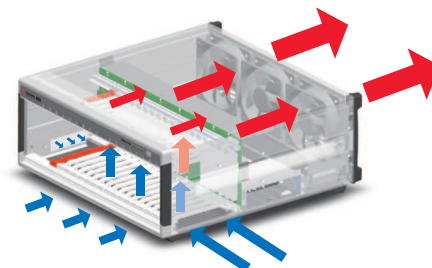

**Specifications**

**Power Supply**

- AC Input
  - Input voltage range: 100 to 240 VAC
  - Input voltage frequency: 50 to 60 Hz
- DC Output
  - Maximum total usable power is 800 W

VDC	Maximum	Load Regulation	Maximum Ripple & Noise
+5 V	29 A	±3%	50 mV
+12 V	45 A	±3%	50 mV
+3.3 V	60 A	±3%	50 mV
-12 V	2.5A	±3%	50 mV

**Bus Interface**

- Four-link/ Two-link/ capacity PXI Express chassis
- Up to 8 GB/s system bandwidth
- Up to 4 GB/s peripheral bandwidth for dedicated slots

**IO/Switch on Rear Panel**

- BNC connectors for 10MHz clock input/output
- Fan speed selector switch
- Inhibit mode selector switch
- D-SUB9 connector for voltage monitoring and remote inhibit
- D-SUB9 connector for remote monitoring

**Cooling**

- Fans: 3 x 185.9 CFM fans, filtered
- Per-slot cooling capacity: 38.2 W

**Physical**

- Number of slots:
  - 1 system slot + 1 system timing slot + 10 hybrid peripheral slots + 6 PXI Express peripheral slots
- Dimensions:
  - 464.3 mm (W) x 191.4 mm (H) x 465.3 mm (D) (18.1" x 7.46" x 18.14")
- Weight: 11.9 kg (26.2 lbs)

**Acoustic Emission**

- Sound Pressure Level (dBA)
    - Auto fan (up to 25 °C ambient): 46.3 dBA
    - High fan: 64.5 dBA
  - Sound Power (dBA)
    - Auto fan (up to 25 °C ambient): 56.0 dBA
    - High fan: 76.0 dBA
- Tested in accordance with ISO 7779

**Operating Environment**

- Ambient temperature: 0°C to 55°C (32 °F to 131 °F)
- Relative humidity: 10% to 90%, non-condensing

**Storage Environment**

- Ambient temperature: -20°C to 70°C (-4 °F to 158 °F)
- Relative humidity: 10% to 90%, non-condensing

**Shock and Vibration**

- Functional shock: 30 G, half-sine, 11 ms pulse duration
- Random vibration:
  - Operating: 5 to 500 Hz, 0.3 Grms, 3 axes
  - Non-operating: 5 to 500 Hz, 2.46 Grms, 3 axes

**Emissions Compliance**

- EN 61326-1
- FCC Class A

**CE Compliance**

- Safety: EN 61010-1
- Immunity: EN 61326-1

**Recommended System Controller**

PXES-2780	
PXIe-3975	√

**Ordering Information**

- **PXES-2780**  
3U 18-slot PXI Express chassis with universal AC power supply

**Optional Accessories**

- **PXES-2780 Rack-mount Kit**  
Flexible rack-mount kit for PXES-2780