

▶ MXE-1200 Series

Intel® Atom™ N270 Fanless Embedded Computer with 12 COM Ports



Introduction

ADLINK's MXE-1200 is based on the Intel® Atom™ N270 1.6 GHz processor and provides 12 serial ports for device communication and control. This distinctive feature delivers to the ability to access multiple devices using a compact and rugged controller without the need for additional serial communication cards.

Leveraging the design of the Matrix MXE-1000 series, the MXE-1200 series retains all the remarkable features of the Matrix E series, including rugged -20 to 70°C fanless operation, 5 Grms vibration resistance, and 6-36 VDC wide range power input. The design of serial ports is also flexible to meet the need of a wide variety of applications. Two of the 12 COM ports can be configured to RS-232, RS-422 or RS-485 via a BIOS setting. Two of the 12 COM ports are RS-232 COM Ports (COM3 & COM4). The remaining eight COM ports are either RS-232 (MXE-1212/232), RS-422 (MXE-1212/422) or RS-485 (MXE-1212/485). The MXE-1200 series is also equipped with a mini-PCIe socket, USIM socket to support expansion of wireless communication capabilities.

Combining reliability, compactness, and a unique feature of 12 COM ports, the MXE-1200 series is the perfect fit for communicating with external devices which will greatly benefit many applications such as toll gate control (RS-232), automatic fare collection systems (RS-232), and smart grid (RS-422/485).

Features

- Intel® Atom™ N270 1.6 GHz processor + 945GSE chipset
- Rugged, -20°C to 70°C fanless operation*
- Provides 12 COM ports
 - Two software-programmable RS-232/422/485 ports (COM1 & COM2)
 - Two RS-232 ports (COM3 & COM4)
 - 8 RS-232 ports (MXE-1212/232), 8 RS-422 ports (MXE-1212/422), 8 RS-485 ports (MXE-1212/485)
- Built-in 6 V_{DC} to 36 V_{DC} wide-range DC power input
- One 1000/100/10 Mbps Ethernet port
- One internal PCIe mini card socket and USIM socket
- One external CF socket

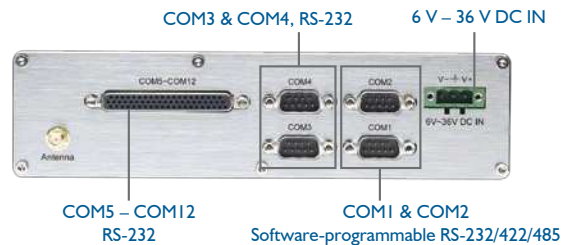

MXE-1212/232 Back Panel

Applications

- Toll Gate Controllers
- Smart Grid Applications
- Intelligent Transportation Systems
- Facility Management
- Environmental Monitoring
- Building Automation

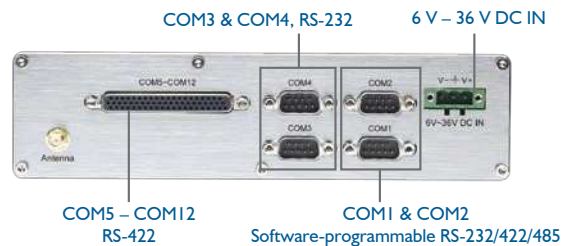

MXE-1212/422 Back Panel

Software Support

- Windows® CE6.0 / XP / XP Embedded / 7

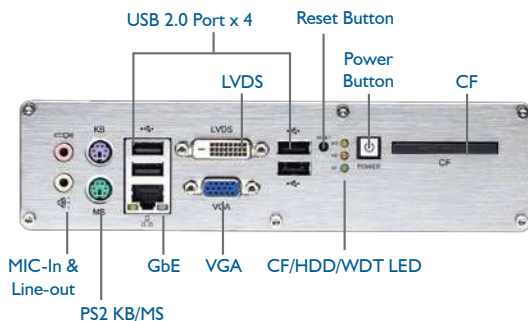

MXE-1200 Series Front Panel

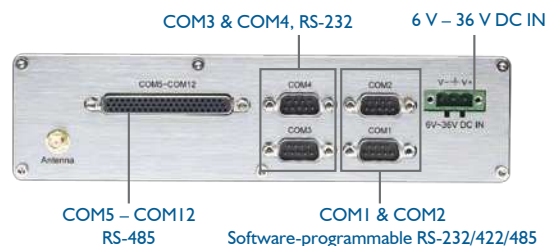

MXE-1212/485 Back Panel



MXE-1200 Series with Antenna

*Extending the operating temperature to -20°C to +70°C is optional and requires use of an industrial solid-state drive storage device.

Specifications

Model Name	MXE-1212/232	MXE-1212/422	MXE-1212/485
System Core			
■ Processor	Intel® Atom™ N270 1.6 GHz CPU		
■ Chipset	Intel® 945GSE Graphic Memory Control Hub Intel® I/O Controller Hub 7 Mobile (ICH7-M)		
■ Video	Analog CRT, supports QXGA (2048 X 1536) resolution 18-bit LVDS output by DVI-D connector for LCD panel		
■ Memory	1 GB DDR2 533 MHz SODIMM module		
I/O Interface			
■ Serial Port	COM1 & COM2	2 software-programmable RS-232/422/485 by DB9 connectors	
	COM3 & COM4	2 RS-232 by DB9 connectors	2 RS-232 by DB9 connectors
	COM5 - COM12	8 RS-232 by DB62 connectors	8 RS-422 by DB62 connectors
■ Ethernet	1 GbE port (Realtek® 8111C)		
■ USB	4 USB 2.0 ports		
■ Mini-PCIe	1 internal PCIe mini card socket		
■ USIM	1 USIM socket for 3G communication (used for a 3G mini-PCIe module)		
■ Audio	1 mic-in and 1 line-out		
■ KB/MS	1 PS/2 keyboard and 1 PS/2 mouse		
Power Supply			
■ DC Input	Built-in 6-36 Vdc wide-range DC input 3P pluggable connector with latch (V-, GND, V+)		
■ AC Input	Optional 40 W external AC-DC adapter for AC input		
Storage Device			
■ SATA HDD	On-board SATA port for 2.5" HDD/SSD installation		
■ CompactFlash	1 type II CF socket, supporting PIO and DMA modes for HDD replacement		
Mechanical			
■ Dimensions	210 mm (W) x 170 mm (D) x 54 mm (H) (8.3" x 6.7" x 2.1")		
■ Weight	1.9 kg (4.19 lbs)		
■ Mounting	VESA 100 mounting kit for wall-mount		
Environmental			
■ Operating Temperature*	Standard: 0°C to 50°C (w/HDD) Extended option: -20°C to 70°C (w/industrial SSD)		
■ Storage Temperature	-40°C to 85°C (excl. HDD/SSD/CF)		
■ Humidity	~95% @ 40°C (non-condensing)		
■ Vibration	Operating, 5 Grms, 5-500 Hz, 3 axes (w/ CF or SSD) Operating, 0.5 Grms, 5-500 Hz, 3 axes (w/ HDD)		
■ Shock	Operating, 100 G, half sine 11 ms duration (w/ CF or SSD)		
■ EMC	CE and FCC		

*Extending the operating temperature to -20°C to +70°C is optional and requires use of an industrial solid-state drive storage device.

Ordering Information

Model Name	Description	COM Ports	GbE	USB	Memory
MXE-1212/232	Intel® Atom™ N270 fanless embedded computer	2 RS-232/422/485 10 RS-232	1	4	1 GB DDR2
MXE-1212/422	Intel® Atom™ N270 fanless embedded computer	2 RS-232/422/485 2 RS-232, 8 RS-422	1	4	1 GB DDR2
MXE-1212/485	Intel® Atom™ N270 fanless embedded computer	2 RS-232/422/485 2 RS-232, 8 RS-485	1	4	1 GB DDR2

Optional Accessories

2 GB DDR2 Upgrade	Upgrade to 2 GB DDR2 memory
320 GB HDD Option	Factory-installed 320 GB SATA hard disk drive (0 to 50°C)
32 GB SSD Option	Factory-installed 32 GB & Intel 40 GB SATA solid-state drive (0 to 70°C)
8 GB Industrial SSD Option	Factory-installed 8 GB industrial-grade SATA solid-state drive (-40 to 85°C)
40 W AC-DC Adapter	40W industrial-grade AC-DC adapter (-20 to 70°C)
Extended Temperature Option*	Optional Screening to extend the operating temperature of the MXE-1200 series to -20°C to 70°C

*This option guarantees cold boot of the system at -20°C and operation with 100% loading at 70°C. The industrial solid-state drive storage option is required.