

M1FH3

30V 1.5A

特長

- 小型SMD
- 極超低 $V_F=0.36V$

Feature

- Small SMD
- Super-Low $V_F=0.36V$

用途

- バッテリー逆接続防止
- DC/DCコンバータ
- 携帯電話、パソコン

Main Use

- Reverse connect protection for DC power source
- DC/DC Converter
- Mobile phone, PC

■外観図 OUTLINE

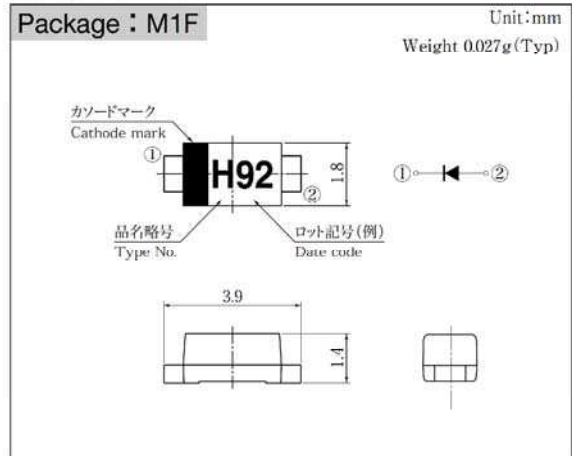

外形図については新電元Webサイト又は〈半導体製品一覧表〉をご参照下さい。捺印表示については捺印仕様をご確認下さい。

For details of the outline dimensions, refer to our web site or Semiconductor Short Form Catalog. As for the marking, refer to the specification "Marking, Terminal Connection".

■定格表 RATINGS

●絶対最大定格 Absolute Maximum Ratings (指定のない場合 $T_c = 25^\circ C$)

項目 Item	記号 Symbol	条件 Conditions	品名 Type No.	M1FH3	単位 Unit
保存温度 Storage Temperature	T_{stg}			-55 ~ 125	$^\circ C$
接合部温度 Operation Junction Temperature	T_j			125	$^\circ C$
せん頭逆電圧 Maximum Reverse Voltage	V_{RM}			30	V
出力電流 Average Rectified Forward Current	I_o	50Hz正弦波, 抵抗負荷, $T_c = 105^\circ C$ 50Hz sine wave, Resistance load, $T_c = 105^\circ C$		1.5	A
せん頭サージ順電流 Peak Surge Forward Current	I_{FSM}	50Hz正弦波, 非繰り返し1サイクルせん頭値, $T_j = 25^\circ C$ 50Hz sine wave, Non-repetitive 1 cycle peak value, $T_j = 25^\circ C$		30	A

●電氣的・熱的特性 Electrical Characteristics (指定のない場合 $T_c = 25^\circ C$)

順電圧 Forward Voltage	V_F	$I_F = 0.5A$, パルス測定 Pulse measurement	MAX 0.30	V
		$I_F = 1.5A$, パルス測定 Pulse measurement	MAX 0.36	
逆電流 Reverse Current	I_R	$V_R = V_{RM}$, パルス測定 Pulse measurement	MAX 1.0	mA
接合容量 Junction Capacitance	C_j	$f = 1MHz, V_R = 10V$	TYP 80	pF
熱抵抗 Thermal Resistance	θ_{jc}	接合部・ケース間 Junction to case	MAX 18	$^\circ C/W$
	θ_{jl}	接合部・リード間 Junction to lead	MAX 20	
	θ_{ja}	接合部・周囲間, プリント基板実装 Junction to ambient, On glass-epoxy substrate	MAX 80	

■特性図 CHARACTERISTIC DIAGRAMS

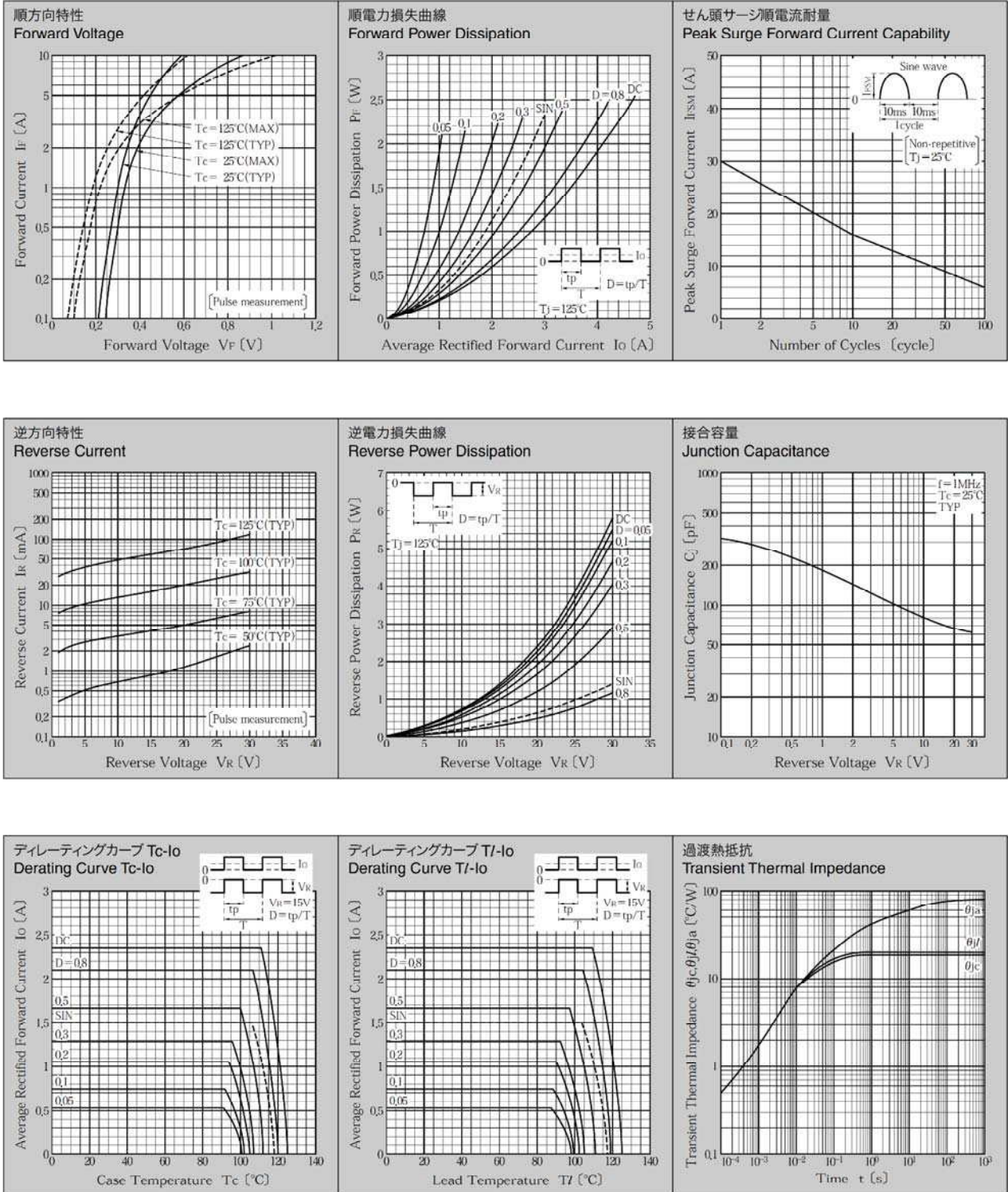

* Sine waveは50Hzで測定しています。
 * 50Hz sine wave is used for measurements.
 * 半導体製品の特性は一般的にバラツキを持っています。
 * Typical is a statistical average of the device's ability.
 * Semiconductor products generally have characteristic variation.
 * Typical is a statistical average of the device's ability.