

D3FS4A**40V 2.6A****特長**

- 小型SMD
- 低 $V_F=0.45V$
- PRISMアバランシエ保証

Feature

- Small SMD
- Low $V_F=0.45V$
- PRISM Rating

用途

- スイッチング電源
- DC/DCコンバータ
- 家電、ゲーム、OA機器
- 通信、ポータブル機器

Main Use

- Switching Regulator
- DC/DC Converter
- Home Appliance, Game, Office Automation
- Communication, Portable set

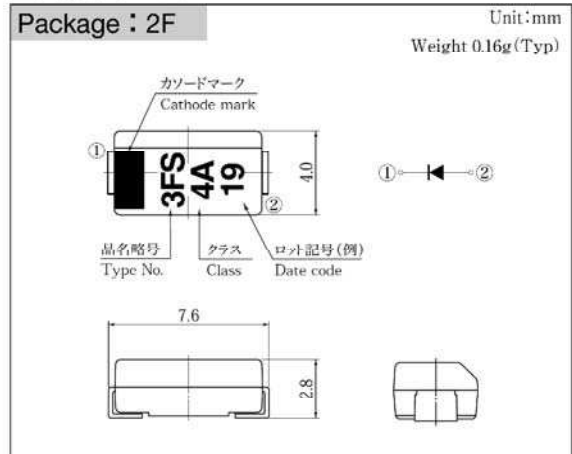
■外観図 OUTLINE

外形図については新電元Webサイト又は〈半導体製品一覧表〉をご参照下さい。捺印表示については捺印仕様をご確認下さい。

For details of the outline dimensions, refer to our web site or Semiconductor Short Form Catalog. As for the marking, refer to the specification "Marking, Terminal Connection".

■定格表 RATINGS**●絶対最大定格 Absolute Maximum Ratings (指定のない場合 $T_I=25^\circ C$)**

項目 Item	記号 Symbol	条件 Conditions	品名 Type No.	D3FS4A	単位 Unit
保存温度 Storage Temperature	T_{stg}			-55~150	$^\circ C$
接合部温度 Operation Junction Temperature	T_j			150	$^\circ C$
せん頭逆電圧 Maximum Reverse Voltage	V_{RM}			40	V
繰り返しせん頭サージ逆電圧 Repetitive Peak Surge Reverse Voltage	V_{RRSM}	パルス幅0.5ms, duty 1/40 Pulse width 0.5ms, duty 1/40		45	V
出力電流 Average Rectified Forward Current	I_o	50Hz正弦波, 抵抗負荷 50Hz sine wave, Resistance load	$T_a=34^\circ C$ アルミナ基板実装 On alumina substrate $T_a=30^\circ C$ プリント基板実装 On glass-epoxy substrate	2.6 1.9	A
せん頭サージ順電流 Peak Surge Forward Current	I_{FSM}	50Hz正弦波, 非繰り返し1サイクルせん頭値, $T_j=125^\circ C$ 50Hz sine wave, Non-repetitive 1 cycle peak value, $T_j=125^\circ C$		150	A
繰り返しせん頭サージ逆電力 Repetitive Peak Surge Reverse Power	P_{RRSM}	パルス幅10 μs , $T_j=25^\circ C$ Pulse width 10 μs , $T_j=25^\circ C$		330	W

●電氣的・熱的特性 Electrical Characteristics (指定のない場合 $T_I=25^\circ C$)

項目 Item	記号 Symbol	条件 Conditions	品名 Type No.	D3FS4A	単位 Unit
順電圧 Forward Voltage	V_F	$I_F=2.6A$, パルス測定 Pulse measurement		MAX 0.45	V
逆電流 Reverse Current	I_R	$V_R=V_{RM}$, パルス測定 Pulse measurement		MAX 5	mA
接合容量 Junction Capacitance	C_j	$f=1MHz$, $V_R=10V$		TYP 340	pF
熱抵抗 Thermal Resistance	θ_{jl}	接合部・リード間 Junction to lead		MAX 23	$^\circ C/W$
	θ_{ja}	接合部・周囲間 Junction to ambient	アルミナ基板実装 On alumina substrate プリント基板実装 On glass-epoxy substrate	MAX 80 MAX 115	

■特性図 CHARACTERISTIC DIAGRAMS

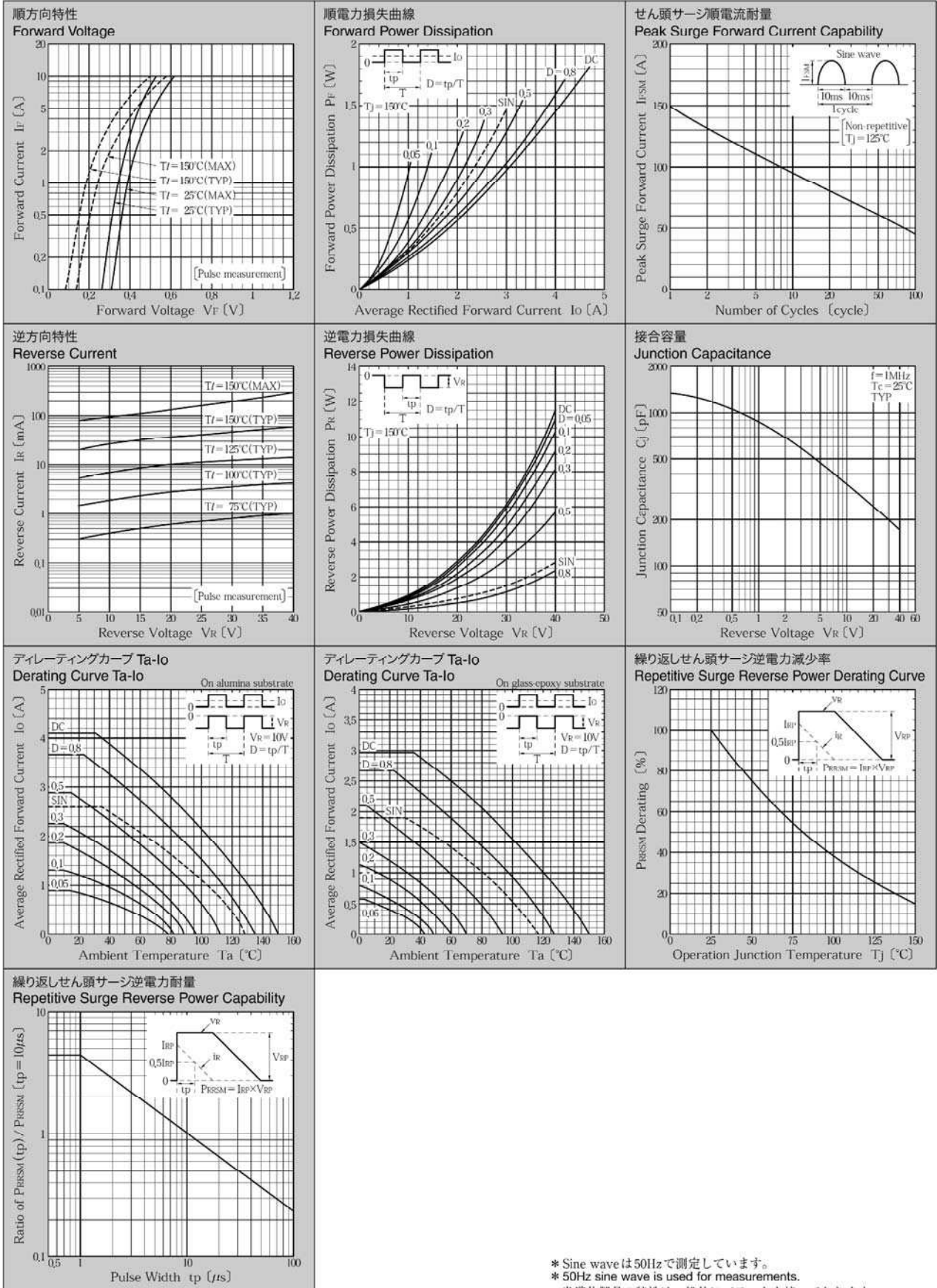

* Sine wave は50Hzで測定しています。
 * 50Hz sine wave is used for measurements.
 * 半導体製品の特性は一般的にバラツキを持っています。
 Typical is a statistical average of the device's ability.
 * Semiconductor products generally have characteristic variation.
 Typical is a statistical average of the device's ability.