

D3FS6**60V 3A****特長**

- 小型SMD
- PRRSMアバランシエ保証

Feature

- Small SMD
- PRRSM Rating

用途

- スイッチング電源
- DC/DCコンバータ
- 家電、ゲーム、OA機器
- 通信、ポータブル機器

Main Use

- Switching Regulator
- DC/DC Converter
- Home Appliance, Game, Office Automation
- Communication, Portable set

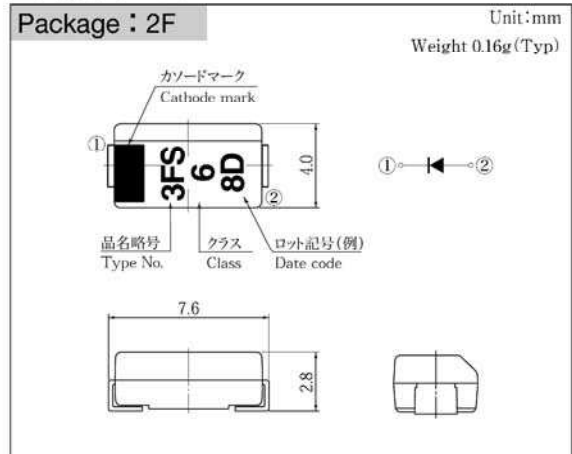
■外観図 OUTLINE

外形図については新電元Webサイト又は《半導体製品一覧表》をご参照下さい。捺印表示については捺印仕様をご確認下さい。

For details of the outline dimensions, refer to our web site or Semiconductor Short Form Catalog. As for the marking, refer to the specification "Marking, Terminal Connection".

■定格表 RATINGS**●絶対最大定格 Absolute Maximum Ratings (指定のない場合 $T_I = 25^\circ\text{C}$)**

項目 Item	記号 Symbol	条件 Conditions	品名 Type No.	D3FS6	単位 Unit
保存温度 Storage Temperature	T_{stg}			-55~150	$^\circ\text{C}$
接合部温度 Operation Junction Temperature	T_j			150	$^\circ\text{C}$
せん頭逆電圧 Maximum Reverse Voltage	V_{RM}			60	V
繰り返しせん頭サージ逆電圧 Repetitive Peak Surge Reverse Voltage	V_{RRSM}	パルス幅0.5ms, duty 1/40 Pulse width 0.5ms, duty 1/40		65	V
出力電流 Average Rectified Forward Current	I_o	50Hz正弦波, 抵抗負荷 50Hz sine wave, Resistance load	$T_a = 25^\circ\text{C}$ アルミナ基板実装 On alumina substrate	1.65	A
			$T_I = 87^\circ\text{C}$	3.0	
せん頭サージ順電流 Peak Surge Forward Current	I_{FSM}	50Hz正弦波, 非繰り返し1サイクルせん頭値, $T_j = 25^\circ\text{C}$ 50Hz sine wave, Non-repetitive 1 cycle peak value, $T_j = 25^\circ\text{C}$		80	A
繰り返しせん頭サージ逆電力 Repetitive Peak Surge Reverse Power	P_{RRSM}	パルス幅10 μs , $T_j = 25^\circ\text{C}$ Pulse width 10 μs , $T_j = 25^\circ\text{C}$		330	W

●電氣的・熱的特性 Electrical Characteristics (指定のない場合 $T_I = 25^\circ\text{C}$)

項目 Item	記号 Symbol	条件 Conditions	品名 Type No.	D3FS6	単位 Unit
順電圧 Forward Voltage	V_F	$I_F = 3.0\text{A}$, パルス測定 Pulse measurement		MAX 0.58	V
逆電流 Reverse Current	I_R	$V_R = V_{RM}$, パルス測定 Pulse measurement		MAX 2.5	mA
接合容量 Junction Capacitance	C_j	$f = 1\text{MHz}$, $V_R = 10\text{V}$		TYP 130	pF
熱抵抗 Thermal Resistance	θ_{jl}	接合部・リード間 Junction to lead		MAX 24	$^\circ\text{C}/\text{W}$
	θ_{ja}	接合部・周囲間 Junction to ambient	アルミナ基板実装 On alumina substrate プリント基板実装 On glass-epoxy substrate	MAX 90 MAX 124	

■特性図 CHARACTERISTIC DIAGRAMS

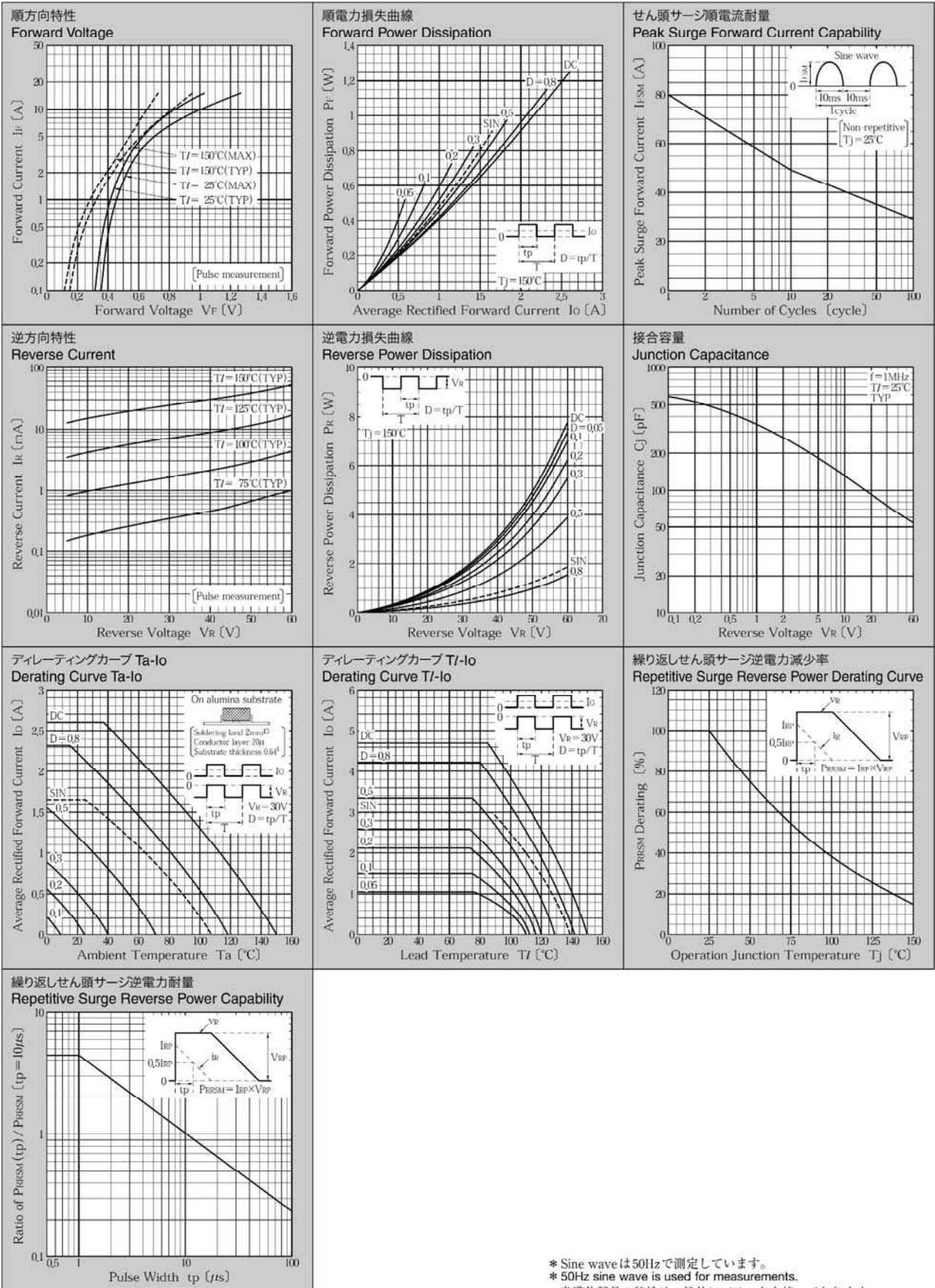

* Sine waveは50Hzで測定しています。
* 50Hz sine wave is used for measurements.
* 半導体製品の特性は一般的にバラツキを持っています。
Typicalは統計的な実力を表しています。
* Semiconductor products generally have characteristic variation.
Typical is a statistical average of the device's ability.